

GOVERNMENT POLYTECHNIC BHUBANESWAR



LECTURE NOTE

ON

CONTROL SYSTEMS & COMPONENT – TH-2

PREPARED BY- SATYABRATA SAHOO, Guest Faculty, E&TC Deptd.

**Branch-Electronics and Telecommunication Engg.
SEMESTER-6TH**

DEPARTMENT OF TELECOMMUNICATION ENGINEERING

1. FUNDAMENTAL OF CONTROL SYSTEM

A system which consists of number of components connected together to perform a specific function in which the output is controlled by input is called as Control System.

OR

Control System is any system that will take the input, then it processes in predefine manner and it will generate desired output.



Example:

- An air conditioner maintains the temperature of the room.
Here air conditioner- control system, maintains the temperature-desired output.
- A car moving from rest to a speed of 100Km/hr.
Here car- control system and speed of 100Km/hr.- desired output

Why we study Control system:

We build control system for four primary reason

- Power Amplification
- Remote control
- Convenience of input form
- Compensation for disturbance

Classification of Control system

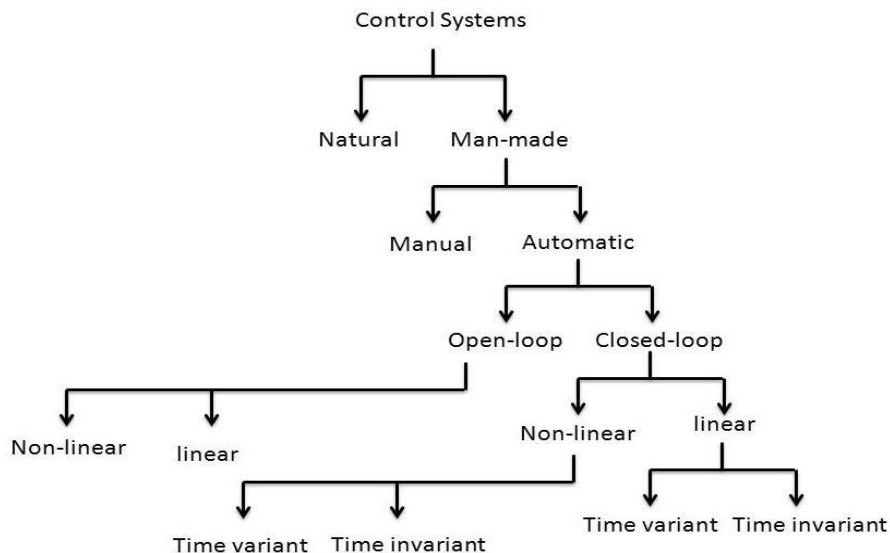

- Natural control systems: Biological systems, systems inside human being are of natural type.
- Manmade control system: The various systems used in daily life are designed and manufactured by human beings. Systems like vehicles, switches, various controllers etc. are called manmade control system.
- Manual control system: A control system in which human operator is necessary is known as manual control system. e.g. Room temperature regulation via Electric Fan, Vehicle, Aeroplane.
- Automatic control system: A control system in which human operator is not at all required, the system known as automatic control system. e.g. Missile launched auto tracked Radar, Home water heating system (Geyser)

- Open loop control system: An open loop control system is a system in which the control action is totally independent of output of the system. e.g. electric hand drier, Automatic washing machine, Bread Toaster, Immersion water heater
- Closed loop control system: A system in which the control action is somehow dependent on the output is called a closed loop control system. e.g. Air conditioner, Automatic Electric Iron, Missile launched and auto tracked by Radar, Cooling system in Car.
- Linear control system: Linear systems are those where the principle of superposition is obeyed.
- Non-linear control system: Non-linear systems do not obey law of superposition
- Time Variant Control system: System whose parameters vary with time are called time variant control system.
- Time Invariant control system: System whose parameters do not vary with time are called time invariant control system

Open loop system & Closed loop system and its comparison

Open loop system

A control system in which the control action is totally independent of the output of the system then it is called an **open-loop control system**.

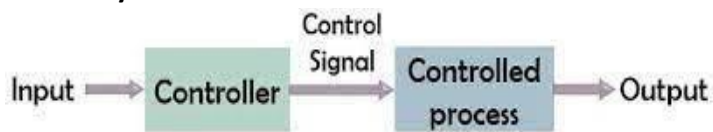

Here, an input is applied to a controller and it produces an actuating signal or controlling signal. This signal is given as an input to a plant or process which is to be controlled. So, the plant/process produces an output, which is controlled.

Example:

- Electric Hand Drier – Hot air (output) comes out as long as you keep your hand under the machine, irrespective of how much your hand is dried.
- Automatic Washing Machine – This machine runs according to the pre-set time irrespective of washing is completed or not.
- Bread Toaster – This machine runs as per adjusted time irrespective of toasting is completed or not.

Advantages of open-loop control systems:

- Simple in construction and design.
- Economical.
- Easy to maintain.
- Generally stable.

Disadvantages of open-loop control systems:

- They are inaccurate.
- They are unreliable.
- Any change in output cannot be corrected automatically.

Closed loop system

Control systems in which the output has an effect on the input quantity in such a manner that the input quantity will adjust itself based on the output generated is called a **closed-loop control system**.

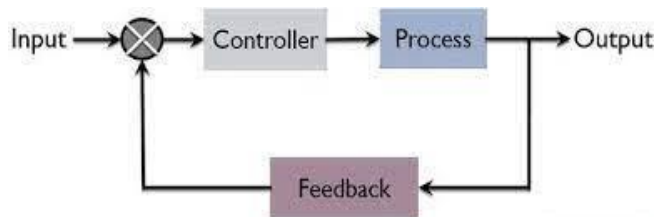

The error detector produces an error signal, which is the difference between the input and the feedback signal. This feedback signal is obtained from the block (feedback elements) by considering the output of the overall system as an input to this block. Instead of the direct input, the error signal is applied as an input to a controller.

So, the controller produces an actuating signal which controls the plant/process. In this combination, the output of the control system is adjusted automatically till we get the desired response. Hence, the closed loop control systems are also called the automatic control systems.

Example:

- Missile Launched and Auto Tracked by Radar – The direction of the missile is controlled by comparing the target and position of the missile.
- An Air Conditioner – An air conditioner functions depending upon the temperature of the room.
- Cooling System in Car – It operates depending upon the temperature which it controls.

Advantages of closed-loop control systems:

- Closed loop control systems are more accurate even in the presence of non-linearity.
- Highly accurate as any error arising is corrected due to the presence of a feedback signal.
- The bandwidth range is large.
- Facilitates automation.
- The sensitivity of the system may be made small to make the system more stable.
- This system is less affected by noise.

Disadvantages of a closed-loop control systems:

- They are costlier.
- They are complicated to design.
- Required more maintenance.
- Feedback leads to an oscillatory response.
- Overall gain is reduced due to the presence of feedback.
- Stability is the major problem and more care is needed to design a stable closed loop system.

Comparison between Open loop and Closed loop control system:

Sl no	Open loop control system	Closed loop control system
1	Control action is independent of the desired output.	Control action is dependent of the desired output.
2	Feedback path is not present.	Feedback path is present.
3	Easy to design.	Difficult to design.
4	It is economical.	It is costly.
5	It is inaccurate.	It is accurate.
6	Less maintenance.	More maintenance.
7	It is unreliable.	It is reliable.
8	Example:	Example:

Effects of Feedback

Feedback:

- If either the output or some part of the output is returned to the input side and utilized as part of the system input, then it is known as Feedback. Feedback plays an important role in order to improve the performance of the control systems.
- There are two types of feedback
 1. Positive Feedback
 2. Negative Feedback

Positive Feedback:

When the feedback signal is positive then the system called a positive feedback system. For a positive feedback system, the error signal is the addition of a reference input signal and a feedback signal.

OR

The type of feedback in a control system in which the input signal and the feedback signal are in phase with each other is known as a positive feedback system.

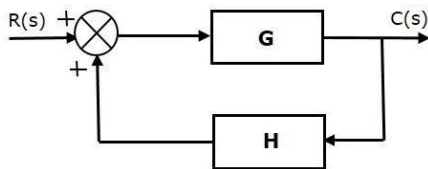

Transfer function of positive feedback control system is

$$T = \frac{G}{1 - GH}$$

Where

- **T** is the transfer function or overall gain of positive feedback control system.
- **G** is the open loop gain, which is function of frequency.
- **H** is the gain of feedback path, which is function of frequency.

Negative Feedback:

When the feedback signal is negative then the system is called a negative feedback system. For the negative feedback system, the error signal is given by the difference between the reference input signal and the feedback signal.

OR

In the case of negative feedback, the input signal and the feedback signal show out-of-phase relationship with respect to each other.

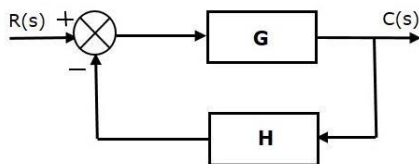

Transfer function of negative feedback control system is

$$T = \frac{G}{1 + GH}$$

Where

- **T** is the transfer function or overall gain of negative feedback control system.
- **G** is the open loop gain, which is function of frequency.
- **H** is the gain of feedback path, which is function of frequency.

**Derivation of Transfer function or Overall gain of the system:

Consider the closed-loop system given below:

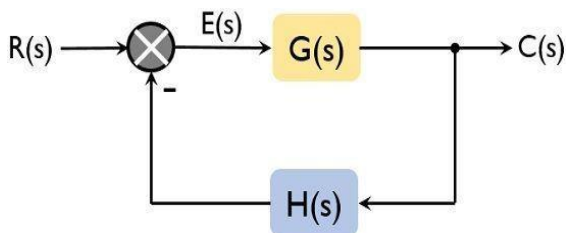

So, for the above-given system,

$$C(s) = E(s) \cdot G(s)$$

$$E(s) = R(s) - H(s)C(s)$$

On substituting the value of E(s) in the 1st equation

$$C(s) = [R(s) - H(s)C(s)] \cdot G(s)$$

$$C(s) = R(s) G(s) - H(s)C(s) G(s)$$

On transposing

$$R(s) G(s) = C(s) + H(s)C(s) G(s)$$

$$R(s) G(s) = C(s) \cdot [1 + G(s) H(s)]$$

$$\frac{C(s)}{R(s)} = \frac{G(s)}{[1 + G(s) H(s)]}$$

This is the transfer function of a closed-loop system with negative feedback.

For a positive feedback system, it is given as:

$$\frac{C(s)}{R(s)} = \frac{G(s)}{[1 - G(s) H(s)]}$$

Effects of Feedback on

1. Gain
2. Sensitivity
3. Stability

Gain:

- The overall gain of negative feedback closed loop control system is, $T = \frac{G}{1+GH}$. So, the overall gain may increase or decrease depending on the value of (1+GH).
- If the value of (1+GH) is less than 1, then the overall gain increases. In this case, 'GH' value is negative because the gain of the feedback path is negative.
- If the value of (1+GH) is greater than 1, then the overall gain decreases. In this case, 'GH' value is positive because the gain of the feedback path is positive.

In general, 'G' and 'H' are functions of frequency. So, the feedback will increase the overall gain of the system in one frequency range and decrease in the other frequency range.

Sensitivity:

Sensitivity of the overall gain of negative feedback closed loop control system (T) to the variation in open loop gain (G) is defined as

$$S_G^T = \frac{\text{Percentage change in } T}{\text{Percentage change in } G} = \frac{\frac{\partial T}{T}}{\frac{\partial G}{G}} \quad \dots\dots (1)$$

Where, ∂T is the incremental change in T due to incremental change in G.

Equation 1 can be written as

$$S_G^T = \frac{\partial T}{\partial G} \times \frac{G}{T} \quad \dots\dots(2)$$

We know that overall gain of closed loop control system is $T = \frac{G}{1+GH}$ (3)

Partial differentiation with respect to G on both sides of Equation 3

$$\frac{\partial T}{\partial G} = \frac{\partial}{\partial G} \left(\frac{G}{1+GH} \right) = \frac{(1+GH) \cdot 1 - (GH)}{(1+GH)^2} = \frac{1}{(1+GH)^2} \quad \dots\dots(4)$$

From Equation 3, you will get

$$\frac{G}{T} = 1+GH \quad \dots\dots(5)$$

Substitute Equation 4 and Equation 5 in Equation 2

$$S_G^T = \frac{1}{(1+GH)^2} \times 1+GH = \frac{1}{(1+GH)}$$

sensitivity of the overall gain of closed loop control system as the reciprocal of (1+GH). So, Sensitivity may increase or decrease depending on the value of (1+GH).

- If the value of (1+GH) is less than 1, then sensitivity increases. In this case, 'GH' value is negative because the gain of feedback path is negative.
- If the value of (1+GH) is greater than 1, then sensitivity decreases. In this case, 'GH' value is positive because the gain of feedback path is positive.

In general, 'G' and 'H' are functions of frequency. So, feedback will increase the sensitivity of the system gain in one frequency range and decrease in the other frequency range.

Stability

- A system is said to be stable, if its output is under control. Otherwise, it is said to be unstable.
- Transfer function of closed loop is $T = \frac{G}{1+GH}$, if the denominator value is zero (i.e., $GH = -1$), then the output of the control system will be infinite. So, the control system becomes unstable.

Therefore, we have to properly choose the feedback in order to make the control system stable.

Standard test Signals (Step, Ramp, Parabolic, Impulse Functions)

The behavior of a system is judged and compared under the application of standard test signal.

Basically 4 major test signal are Impulse, Step, Ramp, Parabolic.

Impulse:

The impulse signal imitate the sudden shock characteristic of actual input signal.

$$\delta(t) = \begin{cases} A & t=0 \\ 0 & t \neq 0 \end{cases}$$

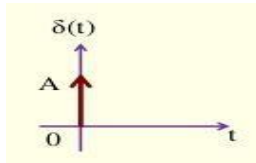

Laplace transform of impulse signal is,

$$L\{\delta(t)\} = \delta(s) = A$$

When $A=1$ then the impulse signal is called Unit Impulse signal.

Step:

The step signal imitate the sudden change characteristic of actual input signal.

$$u(t) = \begin{cases} A & t \geq 0 \\ 0 & t < 0 \end{cases}$$

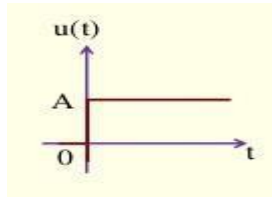

Laplace transform of step signal is,

$$L\{u(t)\} = u(s) = \frac{A}{s}$$

When $A=1$ then the step signal is called Unit Step signal.

$$\text{So, } u(s) = \frac{1}{s}$$

Ramp:

The ramp signal imitate the constant velocity characteristic of actual input signal.

$$r(t) = \begin{cases} At & t \geq 0 \\ 0 & t < 0 \end{cases}$$

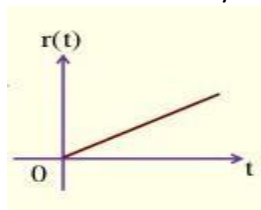

Laplace transform of ramp signal is,

$$L\{r(t)\} = r(s) = \frac{A}{s^2}$$

When $A=1$ then the ramp signal is called Unit Ramp signal.

$$\text{So, } r(s) = \frac{1}{s^2}$$

Parabolic:

The parabolic signal imitate the constant acceleration characteristic of actual input signal.

$$p(t) = \begin{cases} \frac{At^2}{2} & t \geq 0 \\ 0 & t < 0 \end{cases}$$

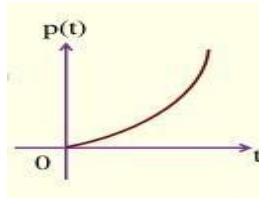

Laplace transform of parabolic signal is

$$L\{p(t)\} = P(s) = \frac{A}{s^3}$$

When $A=1$ then the parabolic signal is called Unit parabolic signal.

$$\text{So, } P(s) = \frac{1}{s^3}$$

Relation between standard Test Signals

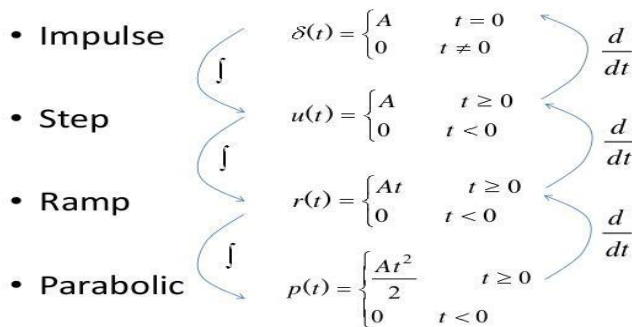

Servomechanism

Any mechanical system or physical quantities automatic control by using the feedback control is called Servomechanism.

Example: A position control system, Automatic tank level control system, DC closed-loop control system, AC closed-loop control system

A position control system:

It is the feedback unit used in a control system. In this system, the control variable is a mechanical signal such as position, velocity or acceleration.

In position control system a servo-system used to position a load shaft. In this, the driving motor is geared to the load to be moved. The potentiometer is used as the error detector. The output and desired positions θ_C and θ_R respectively are measured and compared by the potentiometer pair whose output voltage V_E is proportional to the error in angular position $\theta_E = \theta_R - \theta_C$. The voltage $V_E = K_p \theta_E$ is amplified and is used to control the field current of a DC generator, which supplies armature voltage to the driving motor.

The position control systems have innumerable applications, namely machine tool position control, control of sheet metal thickness in hot rolling mills, radar tracking systems, missile guidance systems, etc.

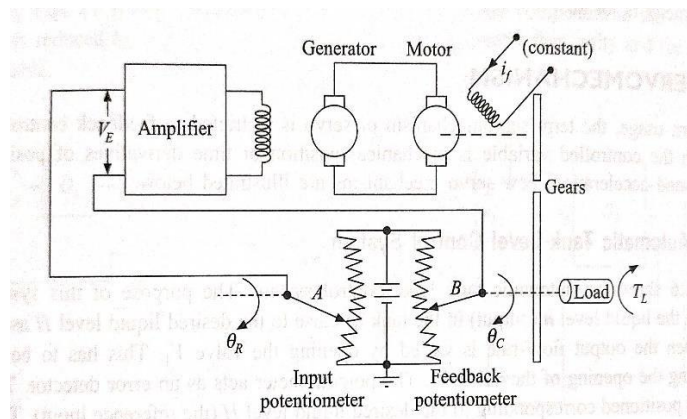

Regulators (Regulating systems)

It is also a feedback unit used in a control system like servomechanism. But, the output is kept constant at its desired value.

Example: Servo stabilizer

2. Transfer Functions

Transfer Function of a system & Impulse response

The transfer function is defined as the ratio of Laplace transform of the output to the Laplace transform of input with all initial conditions are zero.

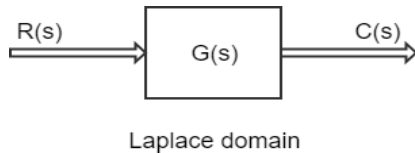

Transfer function can be written as

$$G(S) = \frac{C(S)}{R(S)}$$

Where

C(S) = Laplace transform of output

R(S) = Laplace transform of input

Impulse Response:

An impulse response means the output of a system when the input is an impulse signal.

We know that $G(S) = \frac{C(S)}{R(S)}$

For unit impulse system, $R(S) = 1$ So, $C(S) = G(S)$

The inverse Laplace transform will be, $C(t) = g(t)$ where $g(t)$ is the unit impulse response of a system. Therefore, inverse Laplace of $G(S)$ is called impulse response or the transfer function of a system is the Laplace transform of its impulse response.

Procedure for Determining the Transfer Function of a Control system:

- Formulate the equation for the system.
- Take the Laplace transform of the system equations assuming initial conditions as zero.
- Specify the system output and the input.
- Take the ratio of the Laplace transform of the output and the Laplace transform of the input.

Properties, Advantages & Disadvantages of Transfer Function

Properties of Transfer Function

- The transfer function of a system is the Laplace transfer of its impulse response for zero initial conditions.
- The transfer function can be determined from system input-output pair by taking ratio Laplace of output to Laplace of input.
- The transfer function is independent of the inputs to the system.
- The system poles/zeros can be found out from transfer function.
- The transfer function is defined only for linear time invariant systems. It is not defined for non-linear systems.

Advantages of Transfer Function

- It is a mathematical model that gives the gain of the given block/system.
- Integral and differential equations are converted to simple algebraic equations.
- Once the transfer function is known, any output for any given input, can be known.
- System differential equation can be obtained by replacement of variable 's' by d/dt.
- The value of transfer function is dependent on the parameters of the system and independent of the input applied.

Disadvantages of Transfer Function

- Transfer function is valid only for Linear Time Invariant systems.
- It does not take into account the initial conditions. Initial conditions loose their significance.
- It does not give any idea about how the present output is progressing.

Poles & Zeroes of transfer Function

- Poles and zeros of a transfer function are the frequencies for which the value of the denominator and numerator of transfer function becomes zero respectively.
- The poles of G(S) are those values of 's' which make G(S) tend to infinity
- The zeros of G(S) are those values of 's' which make G(S) tend to zero.
- If either poles or zeros coincide, then such type of poles or zeros are called multiple poles or multiple zeros, otherwise they are known as simple poles or simple zeros. Multiple poles are due to the repetitive factor in denominator and multiple zeros are due to the repetitive factor in numerator of a transfer function.

General form of Transfer Function is

$$G(S) = K \frac{(s-z_1)(s-z_2)\dots(s-z_m)}{(s-p_1)(s-p_2)\dots(s-p_n)}$$

Where z_1, z_2, \dots, z_m are called zeros and p_1, p_2, \dots, p_n are called poles.

Representation of poles & Zero on the s-plane

- The s-plane is the complex plane on which Laplace transforms are graphed.
- In s-plane, X axis as real axis and Y-axis as imaginary axis. The real axis is denoted as σ axis while imaginary axis is denoted as $j\omega$ axis.
- The poles are indicated by symbol 'cross'(X) in s-plane
- The zeros are indicated by symbol of 'small circle'(O) in s-plane.

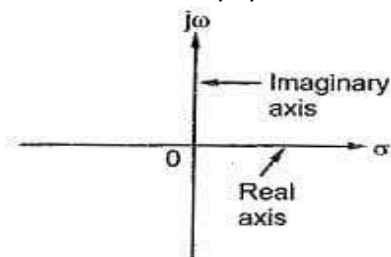

(a) s-plane

Example:

$$G(S) = \frac{(S+1)(S+5)}{S(S+7)}$$

For zero

$$(S+1)(S+5) = 0$$

$$\Rightarrow S = -1, -5$$

For pole

$$S(S+7) = 0$$

$$\Rightarrow S = 0, -7$$

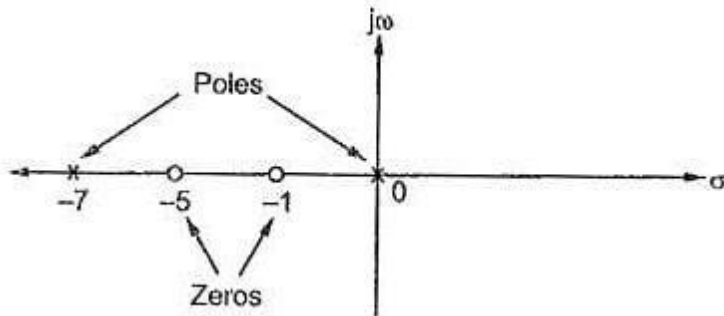

Simple problems of transfer function of network

Write whatever discuss in class

3. CONTROL SYSTEM COMPONENTS & MATHEMATICAL MODELLING OF PHYSICAL SYSTEM

Components of Control System

The basic components of closed loop control system are

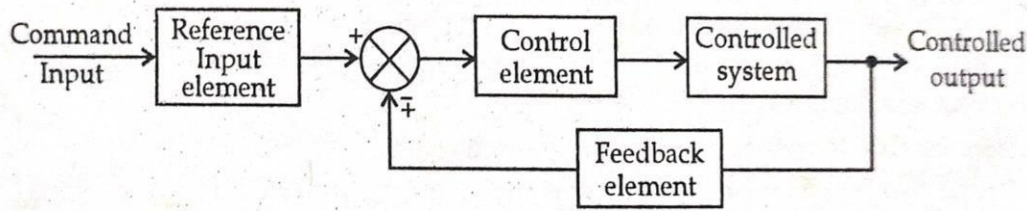

Command/Input: The command is the externally produced input and independent of the feedback control system

Reference input element: This produces the standard signals proportional to the command.

Error Detector: The error detector receives the measured signal and compare it with reference input. The difference of two signals produces the error signal.

Control element: This regulates the output according to the signal obtained from error detector.

Controlled system: This represents what we are controlling by feedback loop.

Feedback element: This element fed back the output to the error detector for comparison with the reference input.

Potentiometer, Synchros

Potentiometer:

- Potentiometer is an electromechanical transducer which converts the mechanical energy (displacement either linear or rotational) into electrical energy(voltage).
- It is also called as Error detecting device because it is used as an error detector in control system. Error in control system is the difference between the output signal and input signal.
- It is inexpensive and easy to apply.

Types of Potentiometer:

1. Linear or Translational Potentiometer
2. Rotational Potentiometer

Linear or Translational Potentiometer:

When voltage applied across the fixed terminals of the potentiometer, the output voltage which is measured across the variable terminals proportional to input displacement.

Under ideal condition, the ratio between the output voltage & input voltage is given by

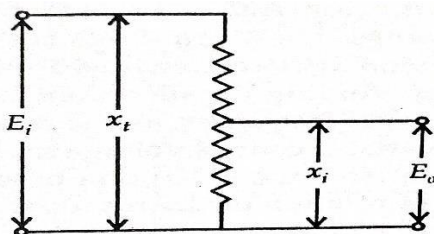

$$\frac{E_o}{E_i} = \frac{x_i}{x_t}$$

Where

E_i = input voltage

E_o = output voltage

x_i = displacement from zero position

x_t = total length of translational potentiometer

Rotational Potentiometer

***diagram

Under ideal condition, the ratio between the output voltage & input voltage is given by

$$\frac{E_0}{E_i} = \frac{\theta_i}{\theta_t}$$

$$E_0 = E_i \frac{\theta_i}{\theta_t}$$

Where

θ_i = input angular displacement (degree or radians)

θ_t = total travel of wiper (degree or radians)

Potentiometer as an Error detector:

Potentiometer can be used as an error detector to compare the positions of two remotely located shafts.

In this arrangement two potentiometers are connected in parallel. The output voltage taken across the variable terminals of the two potentiometer.

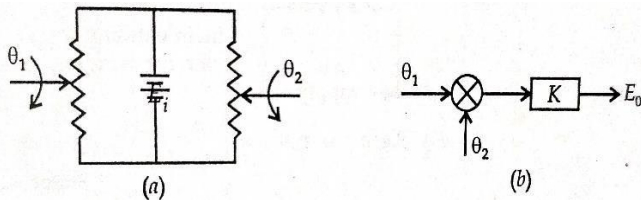

The output voltage E_0 is given by

$$E_0 = K(\theta_1 - \theta_2)$$

Here E_i is the voltage applied, θ_1 & θ_2 are the angular displacement of the wiper, K is constant and is known as sensitivity.

$$K = \frac{E_i}{\theta_t} = \frac{\text{input voltage}}{\text{total angle of rotation}}$$

$$E_0 = \frac{E_i}{\theta_t} (\theta_1 - \theta_2)$$

Synchros

A synchro is an electromagnetic transducer which converts the angular position of a shaft into an electric signal. Synchros are used as detectors and encoders. The error occurs in the system because of the misalignment of the shaft. The transmitter and the control transformer are the two main parts of the synchro.

Synchro Transmitter

- The construction of synchro transmitter is very similar to that of three phase alternator. The stator is made of laminated silicon steel and carries three phase star connected winding. The axis of the stator winding is kept 120° apart from each other. The coils of the stator windings are connected in star.
- The rotor of the synchros is a dumbbell in shape, and a concentric coil is wound on it. The AC voltage is applied to the rotor with the help of slip rings.
- A single phase a.c voltage is applied to the rotor through slip rings. Let the applied a.c voltage to the rotor is

$$e_r = E_r \sin \omega_0 t.$$

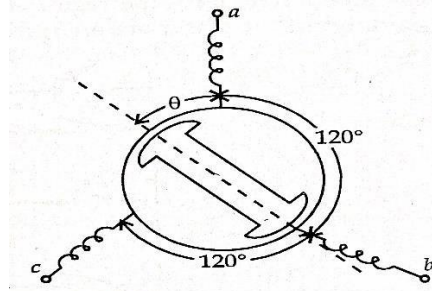

- Due to this applied voltage a magnetizing current will flow in the rotor coil. This magnetizing current produces sinusoidally varying flux and distributed in the air gap. Because of transformer action voltages get induced in all stator coil which is proportional to cosine of angle between stator and rotor coil axes.
- Now, consider the rotor of synchro transmitter is at an angle θ , then voltage in each stator coil with respect to neutral are

$$E_{an} = K \cdot E_r \sin \omega_0 t \cdot \cos \theta$$

$$E_{bn} = K \cdot E_r \sin \omega_0 t \cdot \cos(\theta + 120^\circ)$$

$$E_{cn} = K \cdot E_r \sin \omega_0 t \cdot \cos(\theta + 240^\circ)$$

- Magnitude of stator terminal voltages are

$$E_{cb} = E_{cn} - E_{bn}$$

$$= K \cdot E_r \sin \omega_0 t [\cos(\theta + 240^\circ) - \cos(\theta + 120^\circ)]$$

$$= K \cdot E_r \sin \omega_0 t [\sqrt{3} \sin \theta]$$

$$E_{cb} = \sqrt{3} K \cdot E_r \sin \omega_0 t \cdot \sin \theta$$

- Similarly, $E_{ac} = \sqrt{3} K \cdot E_r \sin \omega_0 t \cdot \sin(\theta + 120^\circ)$ And $E_{ba} = \sqrt{3} K \cdot E_r \sin \omega_0 t \cdot \sin(\theta + 240^\circ)$
- When $\theta = 0$, the maximum induced voltage will be E_{an} and E_{cb} will be zero. This position of the rotor is defined as electrical zero of the transmitter and is used as the reference for indicating the angular position of the rotor.
- Thus, the input to the synchro transmitter is the angular position of the rotor shaft and the output are the three single phase voltages which are the function of the shaft position.

Synchro Control Transformer:

- Principle of operation of synchro control transformer is same as that of synchro transmitter. Rotor of synchro control transformer is cylindrical type. Synchro control transformer is an electromechanical device. The combination of synchro transmitter and synchro control transformer is used as an error detector. The function of error detector is to convert the difference of two shaft positions into an electrical signal.

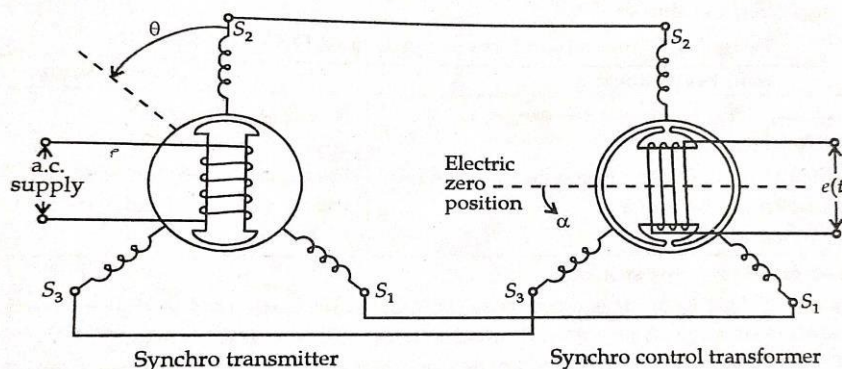

- The output of synchro transmitter is connected to the stator winding of the synchro control transformer. Therefore, the same current will flow in the stator winding of synchro control transformer but in opposite direction. The voltage across the rotor terminals of control transformer is

$$e(t) = K_1 \cdot V_r \cdot \cos \Phi \sin \omega_0 t \dots \dots (1)$$

Where Φ = angular displacement between the two rotors. When the two rotors are at an angle 90° , the voltage induced in control transformer is zero. This position is known as electrical zero position control transformer.

- Let the transmitter rotate through an angle θ in the direction indicated and let control transformer rotor rotates in the same direction through an angle α . Then

$$\Phi = (90^\circ - \theta + \alpha)$$

Put the value of Φ in equation 1, we get

$$e(t) = K_1 V_r \cos(90^\circ - \theta + \alpha) \sin \omega_0 t$$

$$= K_1 V_r \sin(\theta - \alpha) \sin \omega_0 t \dots\dots (2)$$

- From equation 2, it is clear that when the two rotor shaft are not in alignment, the rotor voltage of control transformer is approximately a sine function of the difference between the two shaft angles.
- For small angular displacement between two rotor position

$$e(t) = K_1 V_r (\theta - \alpha) \sin \omega_0 t$$

DC motors, AC Servomotors DC

MOTOR

DC motor is an electro-mechanical device which convert electrical energy into mechanical energy. In control system, the DC motor are used mainly in two different control modes.

- Armature control mode with fixed field current
- Field control mode with fixed armature current

Armature Control DC Motor:

In armature controlled D.C motor, the transfer function of an armature controlled D.C motor relating angular shift in the shaft and the input armature voltage is derived here.

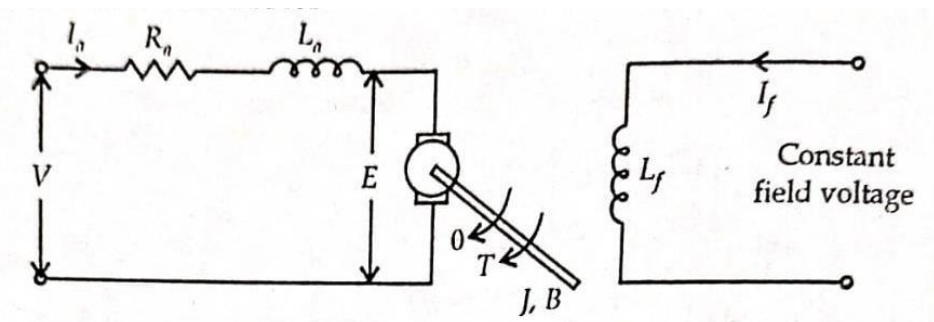

The input voltage V is applied to the armature which has a resistance of R_a and inductance L_a . The field current i_f supplied to the field winding is kept constant and thus the armature input voltage controls the motor shaft output. The moment of inertia and the coefficient of viscous friction at the motor shaft being J and B respectively. The angular shift in the motor shaft being θ and the corresponding angular velocity being ω .

T = Torque developed by the motor

Apply KVL in armature circuit

$$V = R_a i_a + L \frac{di_a}{dt} + E$$

$$V - E = R_a i_a + L \frac{di_a}{dt} \dots\dots\dots (1)$$

Here i_a = Armature current

E = Induced e.m.f in armature

Since field current i_f is constant, the flux Φ will be constant

When armature is rotating, an e.m.f is induced

$$E \propto \Phi \cdot \omega$$

$$E = K_b \omega \dots\dots\dots (2)$$

$$\text{Or } E = K_b \frac{d\theta}{dt}$$

Where ω = angular velocity

K_b = back e.m.f constant

Now, the torque T delivered by the motor will be the product of armature current and flux

$$T \propto \Phi \cdot I_a$$

$$T = K \cdot I_a \dots \dots \dots (3)$$

Where K = motor torque constant

The dynamic equation with moment of inertia & coefficient of friction will be

$$T = J \cdot \frac{d^2\theta}{dt^2} + B \cdot \frac{d\theta}{dt} \dots \dots \dots (4)$$

Take the Laplace transform of equation 1,2,3,4

$$V(s) - E(s) = R_a I_a(s) + s L_a I_a(s)$$

$$E(s) = K_b s \theta(s)$$

$$T(s) = K \cdot I_a(s)$$

$$T = J \cdot s^2 \theta(s) + B s \theta(s) = (Js + B)s \theta(s)$$

The block diag. for each equation

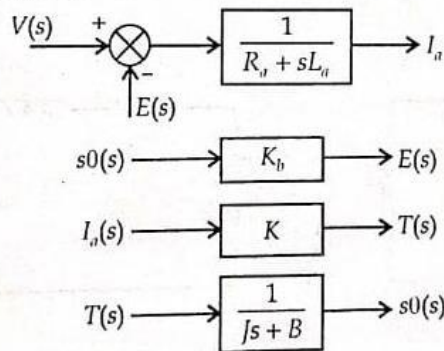

Combine all four block diagrams

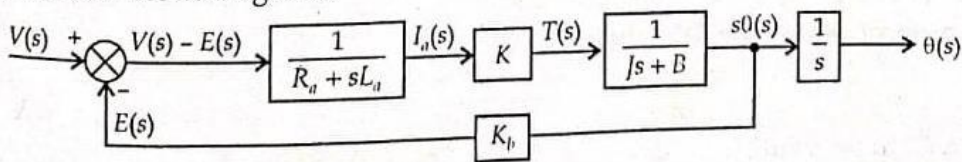

Now determine the transfer function by block reduction method.

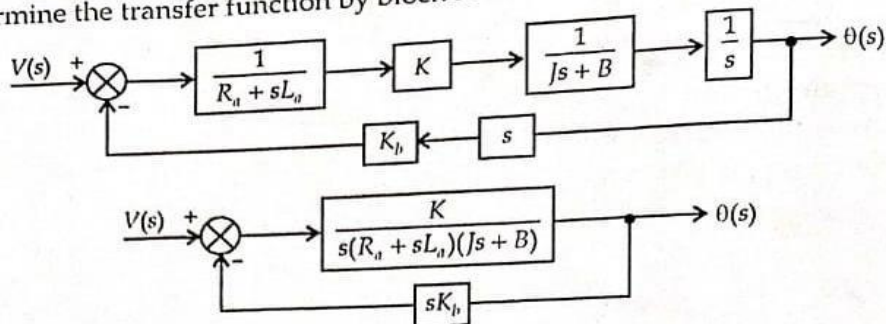

$$\frac{\theta(s)}{V(s)} = \frac{K}{(Ra + sLa)(Js + B)s + KK_b s}$$

$$\frac{\theta(s)}{V(s)} = \frac{K}{R_a \left(1 + s \frac{L_a}{R_a}\right) sB \left(1 + s \cdot \frac{J}{B}\right) + KK_b s}$$

Put $\frac{L_a}{R_a} = \tau_a$ time constant of armature circuit

$\frac{J}{B} = \tau_m$ = mechanical time constant

$$\frac{\theta(s)}{V(s)} = \frac{K}{sR_a B(1 + s\tau_a)(1 + s\tau_m) + KK_b s}$$

Field control DC Motor

In field controlled DC motor, the transfer function of a field controlled DC motor relating angular shift in the shaft and the input field voltage is derived here

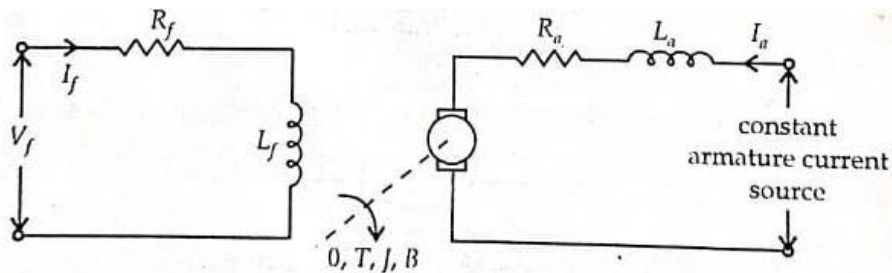

The input voltage V_f is applied to the field winding which has a resistance and inductance of R_f and L_f respectively. The armature current I_a supplied to the armature is kept constant and thus the motor shaft is controlled by the input voltage V_f . The field current I_f produced a flux in the machine which in turn produces a torque at the motor shaft. The moment of inertia and the coefficient of viscous friction at the motor shaft are J and B respectively. The angular shift resulting in the motor shaft being θ and the corresponding angular velocity being ω .

Here the flux is proportional to the field current

$$\Phi \propto I_f$$

$$\Phi = K_f I_f$$

Apply KVL in field circuit

$$V_f = R_f I_f + L_f \frac{dI_f}{dt}$$

Torque developed by the motor is proportional to the flux and armature current.

$$T \propto \Phi I_a$$

$$T = K' K_f I_a I_f$$

$$T = KK_f I_f$$

$$K = K' I_a$$

where

Dynamic equation of torque in terms of J & B

$$T = J \frac{d^2\theta}{dt^2} + B \frac{d\theta}{dt}$$

Laplace transform of all equations are

$$V_f(s) = R_f I_f(s) + sL_f I_f(s)$$

$$= I_f(s) [R_f + sL_f]$$

$$I_f = \frac{V_f(s)}{R_f + sL_f}$$

$$T(s) = KK_f I_f(s)$$

$$T(s) = \theta(s) [s^2 J + sB]$$

So

$$T(s) = K \cdot K_f \cdot \frac{V_f(s)}{R_f + sL_f}$$

$$\theta(s) [s^2J + sB] = K \cdot K_f \cdot \frac{V_f(s)}{R_f + sL_f}$$

$$\frac{\theta(s)}{V_f(s)} = \frac{KK_f}{s(sJ + B)(R_f + sL_f)}$$

$$\frac{\theta(s)}{V_f(s)} = \frac{KK_f}{R_f Bs \left(1 + s \frac{J}{B}\right) \left(1 + s \frac{L_f}{R_f}\right)}$$

$$\frac{\theta(s)}{V_f(s)} = \frac{KK_f}{R_f Bs(1 + s\tau_m)(1 + s\tau_f)}$$

where

$$\tau_m = \frac{J}{B} = \text{mechanical time constant}$$

$$\tau_f = \frac{L_f}{R_f} = \text{time constant for field circuit}$$

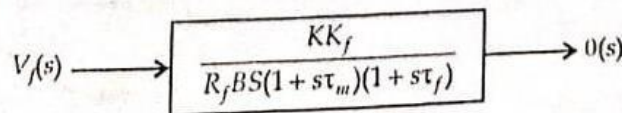

AC SERVO MOTOR

- AC servomotors are two phase induction motor having two parts namely stator and rotor.
- The stator has two distributed winding; these winding is displaced from each other by 90° electrical. One winding is called main winding or reference winding. The reference winding is excited by constant a.c voltage. The other winding is called control winding. This winding is excited by variable control voltage of the same frequency as the reference winding but having a phase displacement of 90° electrical. The variable control voltage for control winding is obtained from a servo amplifier.
- The direction of rotation depends upon phase relationship of voltages applied to the two winding. The direction of rotation of the rotor can be reversed by reversing the phase difference between control voltage and reference voltage.

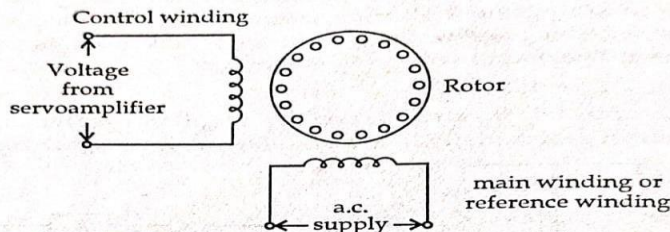
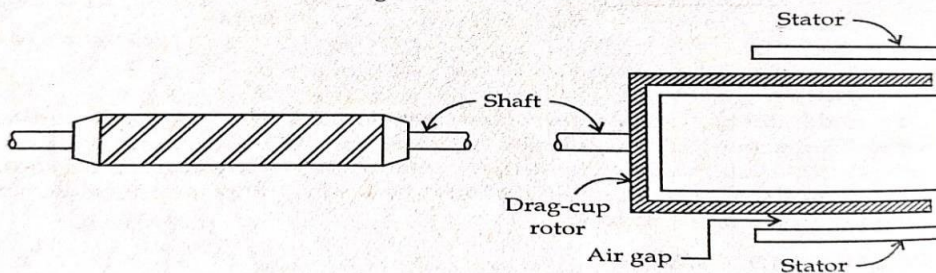

Fig. 9.4. a.c. servomotor



Squirrel cage rotor

Drag cup rotor

- The rotor of a.c servomotors are of two types a) squirrel cage rotor b) drag cup type rotor. The squirrel cage rotor having large length and small diameter, so its resistance is very high. The air gap of squirrel cage is kept small. In drag cup type there are two air gaps. For the rotor a cup of non-magnetic conducting material is used. A stationary iron core is placed between the conducting cup to complete the magnetic circuit. The resistance of drag cup type is high and therefore having high starting torque. Generally, aluminum is used for cup.
- The torque speed characteristic of two phase induction motor depends upon the ratio of reactance to resistance. For high resistance and low reactance, the characteristic is linear and for large value of X to R becomes non-linear. The torque-speed characteristics for various control voltages are almost linear.

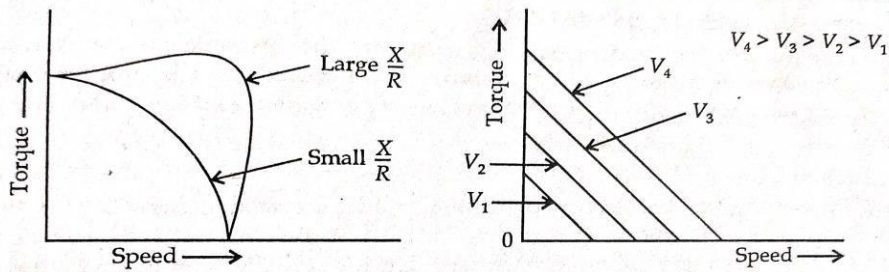

TRANSFER FUNCTION OF AN AC SERVO MOTOR

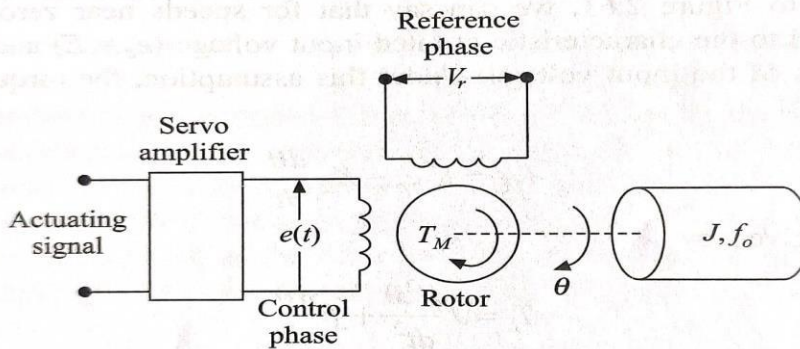

T_M = torque developed by servomotor

θ = angular displacement of rotor

$\omega = d\theta/dt$ = angular speed

T_l = torque required by the load

J = moment of inertia of load and the rotor

K_1 = slope of control-phase voltage versus torque characteristics

K_2 = slope of torque-speed characteristic

With reference to Figure 2.61, we can say that for speeds near zero, all the curves are straight lines parallel to the characteristic at rated input voltage ($e_c = E$) and are equally spaced for equal increments of the input voltage. Under this assumption, the torque developed by the motor is

$$T_M = K_1 e_c - K_2 \frac{d\theta}{dt} \quad (2.22)$$

The load torque is given by

$$T_l = J \frac{d^2\theta}{dt^2} + f \frac{d\theta}{dt} \quad (2.23)$$

At equilibrium, the motor torque is equal to the load torque. Therefore,

$$\therefore J \frac{d^2\theta}{dt^2} + f \frac{d\theta}{dt} = K_1 e_c - K_2 \frac{d\theta}{dt} \quad (2.24)$$

Taking the Laplace transform on both sides of Eq. (2.24) and neglecting initial conditions, we get

$$Js^2\theta(s) + fs\theta(s) = K_1E_c(s) - K_2s\theta(s)$$

$$(Js^2 + fs + K_2s)\theta(s) = K_1E_c(s)$$

i.e.

The transfer function of the system is therefore

$$\frac{\theta(s)}{E_c(s)} = \frac{K_1}{Js^2 + fs + K_2s} = \frac{K_1}{s(f + K_2) \left[\frac{Js^2}{s(f + K_2)} + 1 \right]}$$

$$= \frac{K_1/(f + K_2)}{s \left(\frac{J}{f + K_2} s + 1 \right)} = \frac{K_m}{s(\tau_m s + 1)}$$

where $K_m = \frac{K_1}{f + K_2}$ = motor gain constant

$\tau_m = \frac{J}{f + K_2}$ = motor time constant

Modelling of Electrical Systems (R, L, C, Analogous systems)

Two systems are said to be analogous to each other if the following two conditions are satisfied.

- The two systems are physically different
- Differential equation modelling of these two systems are same

Electrical systems and mechanical systems are two physically different systems. There are two types of electrical analogies of translational mechanical systems. Those are force voltage analogy and force current analogy.

Force Voltage Analogy

In force voltage analogy, the mathematical equations of translational mechanical system are compared with mesh equations of the electrical system.

Consider the following translational mechanical system as shown in the following figure.

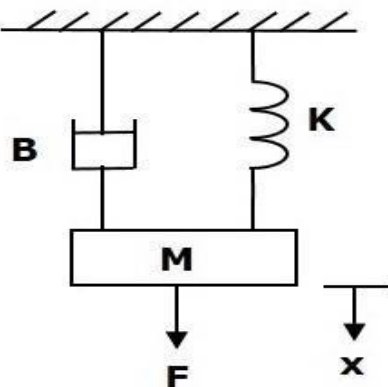

The force balanced equation for this system is

$$F = F_m + F_b + F_k$$

$$\Rightarrow F = M \frac{d^2x}{dt^2} + B \frac{dx}{dt} + Kx \dots \dots \dots (1)$$

Consider the following electrical system as shown in the following figure. This circuit consists of a resistor, an inductor and a capacitor. All these electrical elements are connected in a series. The input voltage applied to this circuit is V volts and the current flowing through the circuit is i Amps.

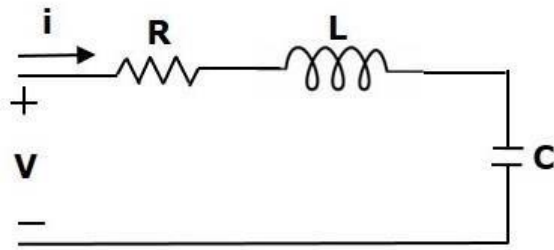

Mesh equation for this circuit is

$$V = Ri + L \frac{di}{dt} + \frac{1}{C} \int i dt \dots\dots\dots (2)$$

Substitute, $i = \frac{dq}{dt}$

$$V = R \frac{dq}{dt} + L \frac{d^2q}{dt^2} + \frac{q}{C}$$

$$\Rightarrow V = L \frac{d^2q}{dt^2} + R \frac{dq}{dt} + \left(\frac{1}{C}\right)q \dots\dots\dots (3)$$

By comparing Equation 1 and Equation 3, we will get the analogous quantities of the translational mechanical system and electrical system. The following table shows these analogous quantities.

Translational Mechanical System	Electrical System
Force(F)	Voltage(V)
Mass(M)	Inductance(L)
Frictional Coefficient(B)	Resistance(R)
Spring Constant(K)	Reciprocal of Capacitance ($\frac{1}{C}$)
Displacement(x)	Charge(q)
Velocity(v)	Current(i)

Force Current Analogy

In force current analogy, the mathematical equations of the translational mechanical system are compared with the nodal equations of the electrical system.

Consider the following electrical system as shown in the following figure. This circuit consists of current source, resistor, inductor and capacitor. All these electrical elements are connected in parallel.

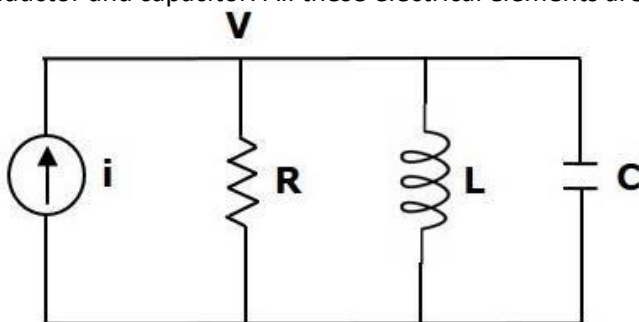

The nodal equation is

$$i = \frac{V}{R} + \frac{1}{L} \int V dt + C \frac{dV}{dt} \dots\dots\dots(4)$$

Substitute, $V = \frac{d\Phi}{dt}$ in equation 4

$$i = \frac{1}{R} \frac{d\Phi}{dt} + \frac{1}{L} (\Phi) + C \frac{d^2\Phi}{dt^2}$$

$$\Rightarrow i = C \frac{d^2\Phi}{dt^2} + \frac{1}{R} \frac{d\Phi}{dt} + \frac{1}{L} (\Phi) \dots\dots\dots (5)$$

By comparing Equation 1 and Equation 6, we will get the analogous quantities of the translational mechanical system and electrical system. The following table shows these analogous quantities.

Translational Mechanical System	Electrical System
Force(F)	Current(i)
Mass(M)	Capacitance(C)
Frictional coefficient(B)	Reciprocal of Resistance ($\frac{1}{R}$)
Spring constant(K)	Reciprocal of Inductance ($\frac{1}{L}$)
Displacement(x)	Magnetic Flux(Φ)
Velocity(v)	Voltage(V)

4. Block Diagram & Signal Flow Graphs(SFG)

Definition of Basic Elements of a Block Diagram

- Block diagram is nothing but the pictorial representation of the components integrated in control system and flow of signal through the components.
- The basic elements of a block diagram are a block, the summing point and the take-off point.

Block:

The transfer function of a component is represented by a block. Block has single input and single output.

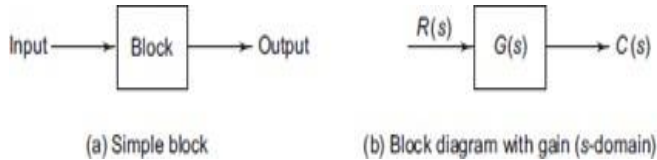

Summing Point:

The point in the block diagram representation where the multiple signals are compared is known as the summing point.

The summing point is represented with a circle having cross (X) inside it.

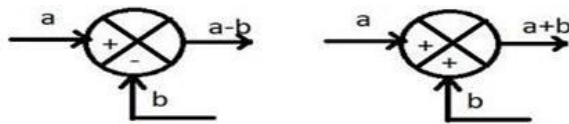

Take-off Point:

The take-off point is a point from which the same input signal can be passed through more than one branch. That means with the help of take-off point, the same input can apply to one or more blocks, summing points.

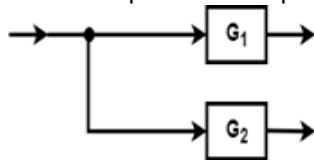

Canonical Form of Closed Loop Systems

A closed loop system is one in which output is fed back into an error detector and compared with the reference input. The feedback may be negative or positive.

Consider a closed loop system shown in figure below

Where

$R(s)$ = Reference input

$E(s)$ = Actuating signal or error signal

$G(s)$ = Forward path transfer function

$C(s)$ = Output signal

$H(s)$ = Feedback transfer function

$B(s)$ = Feedback signal

Here

$$C(s) = G(s) \cdot E(s) \dots \dots \dots (1)$$

$$B(s) = H(s) \cdot C(s) \dots \dots \dots (2)$$

$$E(s) = R(s) - B(s) \dots \dots \dots (3)$$

Put the value of C(s) from equation (1) in equation (2)

$$B(s) = H(s) \cdot G(s) \cdot E(s)$$

$$\frac{B(s)}{E(s)} = G(s) \cdot H(s)$$

$$\frac{B(s)}{E(s)} = \text{Open loop transfer function} = G(s) \cdot H(s) \dots\dots\dots (4)$$

Put the value of E(s) from equation (3) from equation (1)

$$C(s) = G(s)[R(s) - B(s)]$$

$$C(s) = R(s) \cdot G(s) - G(s) \cdot B(s) \dots\dots\dots (5)$$

Put the value of B(s) from equation (2) in equation (5)

$$C(s) = R(s) \cdot G(s) - G(s) \cdot H(s) \cdot C(s)$$

$$\text{Or } C(s)[1 + G(s) \cdot H(s)] = R(s) \cdot G(s)$$

$$\text{Or } \frac{C(s)}{R(s)} = \frac{G(s)}{1 + G(s) \cdot H(s)} \dots\dots\dots (6)$$

$$\frac{C(s)}{R(s)} = M(s) = \text{Closed loop transfer function} = \frac{G(s)}{1 + G(s) \cdot H(s)}$$

If the feedback is **positive**, then equation (6) becomes

$$\frac{C(s)}{R(s)} = \frac{G(s)}{1 - G(s) \cdot H(s)} \dots\dots\dots (7)$$

From equation (1) put the value of C(s) in equation (6)

$$\frac{G(s)E(s)}{R(s)} = \frac{G(s)}{1 + G(s) \cdot H(s)}$$

$$\frac{E(s)}{R(s)} = \frac{1}{1 + G(s) \cdot H(s)} \dots\dots\dots (8)$$

$$\frac{E(s)}{R(s)} = \text{Error ratio} = \frac{1}{1 + G(s) \cdot H(s)}$$

For positive feedback

$$\frac{E(s)}{R(s)} = \frac{1}{1 - G(s) \cdot H(s)} \dots\dots\dots (9)$$

Put the value of C(s) from equation (1) in equation (2)

$$B(s) = H(s) \cdot G(s) \cdot E(s)$$

Put the value of E(s) from equation (3) in above equation

$$B(s) = H(s) \cdot G(s)[R(s) - B(s)] \dots\dots\dots (10)$$

From equation (10)

$$\frac{B(s)}{R(s)} = \frac{G(s) \cdot H(s)}{1 + G(s) \cdot H(s)}$$

$$\frac{B(s)}{R(s)} = \text{Primary feedback ratio} = \frac{G(s) \cdot H(s)}{1 + G(s) \cdot H(s)}$$

For positive feedback

$$\frac{B(s)}{R(s)} = \frac{G(s).H(s)}{1-G(s).H(s)}$$

A unity feedback control system is shown below

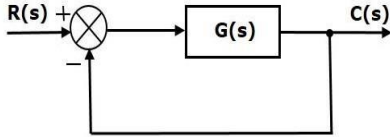

For unity feedback control system $H(s)=1$

$$\frac{C(s)}{R(s)} = \frac{G(s)}{1+G(s).H(s)} \quad \text{for negative feedback}$$

$$\frac{C(s)}{R(s)} = \frac{G(s)}{1-G(s).H(s)} \quad \text{for positive feedback}$$

Rules for Block Diagram Reduction

Rule No.1. Blocks in Cascade

When two or more blocks are connected **in series**, then the resultant block is the product of the individual blocks.

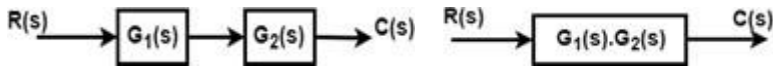

Rule No.2 Blocks in parallel

When two or more blocks are connected in parallel, then the resultant block is the sum of the individual blocks.

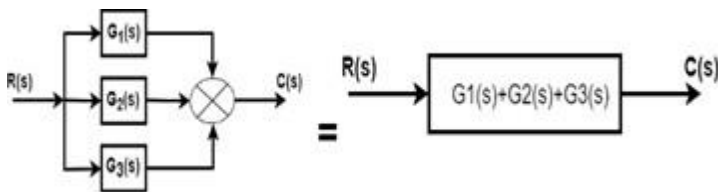

Rule No.3 Moving a take-off point ahead of a block

When the take-off point is moved ahead of a block (before the block), then the same transfer function is introduced in the take-off point branch.

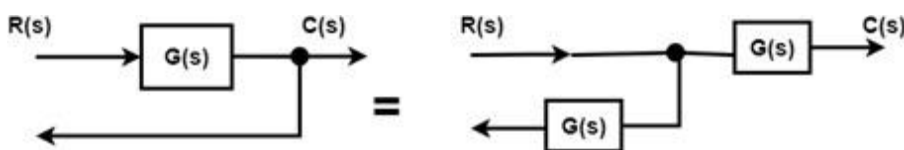

Rule No.4 Moving the take-off point after the block

When the take-off point is moved after the block, then a block with reciprocal of a transfer function is introduced in the take-off point branch.

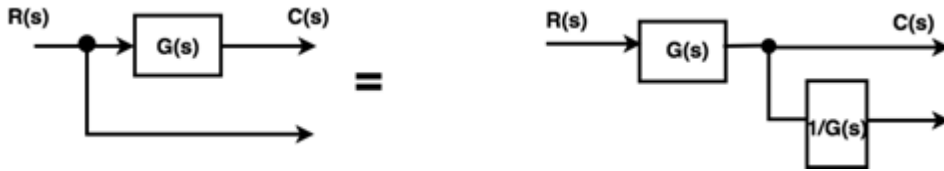

Rule No.5 Moving a summing point beyond the block

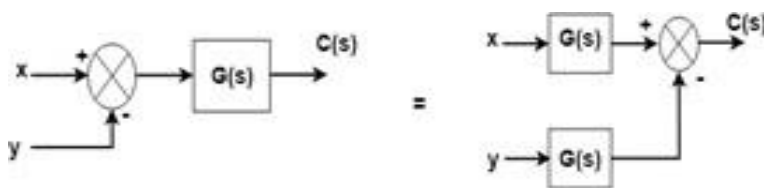

Rule No.6: Moving a summing point ahead of a block

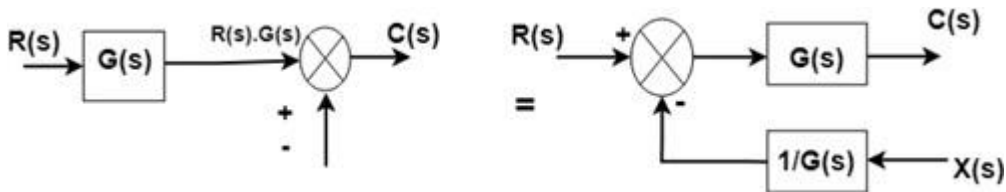

Rule No.7: Interchanging two summing points

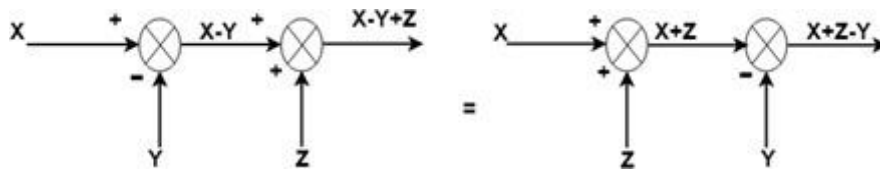

Rule No.8: Moving a take-off point beyond a summing point

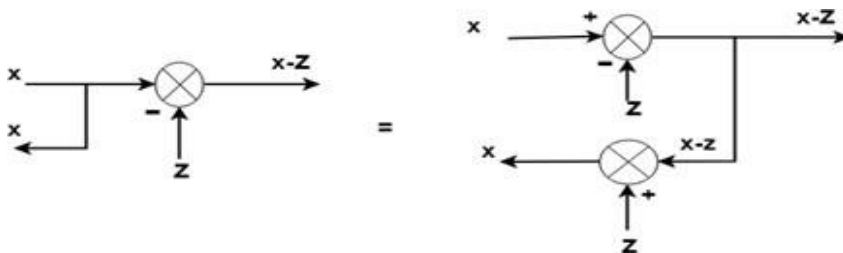

Rule No.9: Moving a take-off point ahead of a summing point

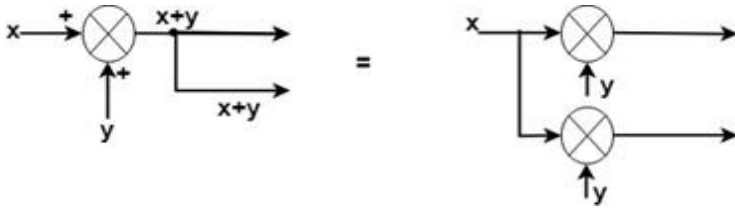

Rule No.10: Eliminating a forward loop

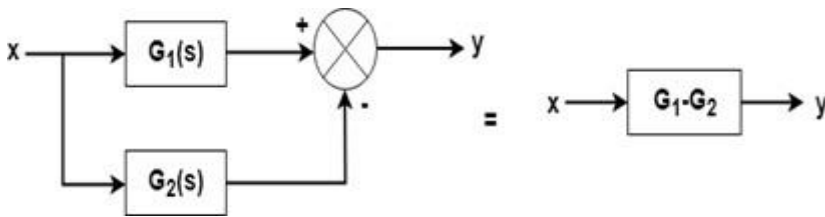

Procedure for of Reduction of Block Diagram

- Check for the blocks connected in series and simplify.
- Check for the blocks connected in parallel and simplify.
- Check for the blocks connected in feedback loop and simplify.
- If there is difficulty with take-off point while simplifying, shift it towards right.
- If there is difficulty with summing point while simplifying, shift it towards left.
- Repeat the above steps till you get the simplified form, i.e., single block.

Simple Problem for equivalent transfer function

Basic Definition in SFG & properties

SIGNAL FLOW GRAPH (SFG)

- Signal flow graph is a graphical representation of block diagram.
- SFG is also used to determine the overall transfer function of a control system.
- SFG is an easier method to determine the transfer function as compared to Block Diagram Reduction as we do not have to reduce the SFG.

The following terms are associated with the signal flow graph.

1. Node: The small points or circles in the signal flow graph are called nodes and these are used to show the variables of the system. Each node corresponds to an individual variable. In the figure given below x_1 to x_8 are nodes.

2. Input node or source: The one having branches with only outgoing signal is known as the input node or source. For the below shown SFG, x_1 is the source.

3. Output node or sink: A node that only contains branches with entering signal is known as a sink or output node. Both input and output nodes act as dependent variables. Here, x_8 is the sink.

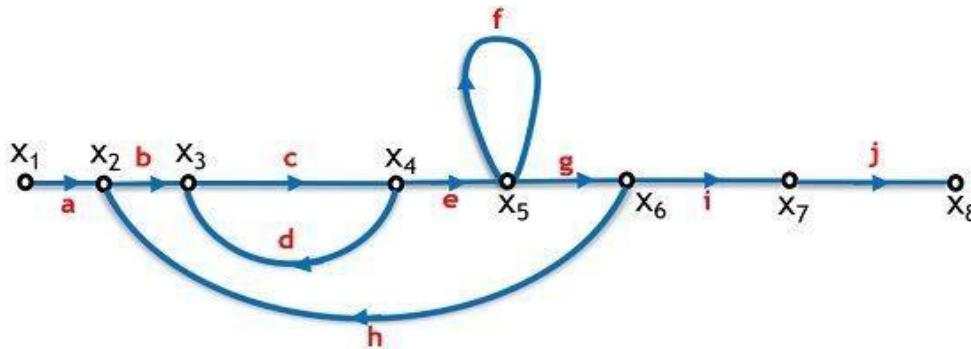

4. Mixed node: It is also known as chain node and consists of branches having both entering as well as leaving signals. For this SFG, x_2 to x_7 are mixed nodes.

5. Branch: The lines in the SFG that join one node to the other is known as a branch. It shows the relationship existing between various nodes.

6. Transmittance: The transfer function or gain between two nodes is said to be the transmittance of the SFG. Its value can be either real or complex. These are from 'a' to 'j' here.

7. Forward path: A path proceeding from input to output is known as forward path. Here the path is $x_1 - x_2 - x_3 - x_4 - x_5 - x_6 - x_7 - x_8$.

8. Feedback loop: A loop which is formed through a path starting from a specific node and ending on the same node after travelling to at least one node of the graph is known as a feedback loop. It is to be noted that in the feedback loop, no node should be traced twice. Here the loop is x_2 to x_6 then back to x_2 and x_3 to x_4 then back to x_3 .

9. Self-loop: A self-loop is the one which has only a single node. The paths in such loops are never defined by a forward path or feedback loop as these never trace any other node of the graph. Here it is formed at node x_5 having gain f .

10. Path gain: When the signal flows in a forward path then the product of gains of each branch gives the overall path gain. For above-given graph, $a.b.c.e.g.i.j$ is path gain for forward path, x_1 to x_8 .

11. Loop gain: The product of individual gains of the branches that are in the form of loop is said to be the overall loop gain. For the loop forming between x_3 and x_4 the gain is $c.d$.

12. Non-touching loops: When two or more loops do not share common nodes then such loops are called non-touching loops. For this SFG, the two non-touching loops are x_3 to x_4 to x_3 and x_5

Properties of Signal Flow Graph

- The signal from a node to other flows through the branch in the direction of arrowhead.
- The graphical method is valid only for linear time-invariant systems.
- The signal flowing through a branch is multiplied by the gain or transmittance of that branch. This product is equivalent to the node where that branch is terminating.

- Another crucial property of SFG is that, at any particular node, the value of the variable will be the algebraic summation of the signals coming to that node.
- The value that a node represents is not affected by the number of outgoing branches from that node.
- The signal flow graph never uniquely denotes a system as for a system multiple graphs can be formed by writing the equations differently.

Methods to Obtain Signal Flow Graph

There are two ways by which a signal flow graph can be constructed. One way to form an SFG is by using systems equation. While the other way of constructing SFG is by using the block diagram.

SFG from system equations

The steps are as follows:

- First represent each variable of the equation by an individual node.
- Further, the value of the variable at a node is obtained by summing up all the signals that are coming to that node. So, draw the branches to that node accordingly.
- The coefficient of the variables present in an equation will be the gain of the branches that are joining the nodes.
- Furthermore, locate the input and output variables of the equations in the signal flow graph.

Signal flow graph by considering the following algebraic equations –

$$y_2 = a_{12}y_1 + a_{42}y_4$$

$$y_3 = a_{23}y_2 + a_{53}y_5$$

$$y_4 = a_{34}y_3$$

$$y_5 = a_{45}y_4 + a_{35}y_3$$

$$y_6 = a_{56}y_5$$

There will be six **nodes** (y_1, y_2, y_3, y_4, y_5 and y_6) and eight **branches** in this signal flow graph. The gains of the branches are $a_{12}, a_{23}, a_{34}, a_{45}, a_{56}, a_{42}, a_{53}$ and a_{35} .

Step 1 – Signal flow graph for $y_2 = a_{12}y_1 + a_{42}y_4$ is shown in the following figure.

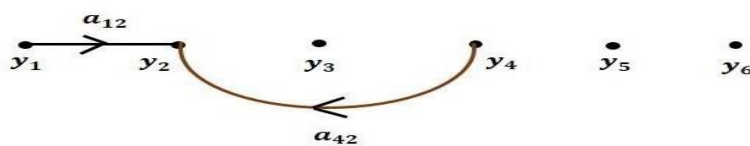

Step 2 – Signal flow graph for $y_3 = a_{23}y_2 + a_{53}y_5$ is shown in the following figure.

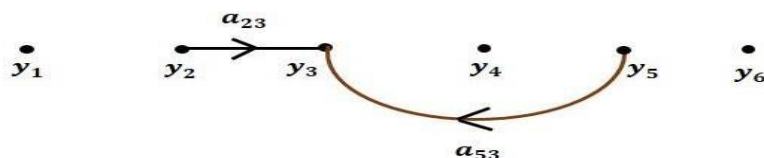

Step 3 – Signal flow graph for $y_4 = a_{34}y_3$ is shown in the following figure.

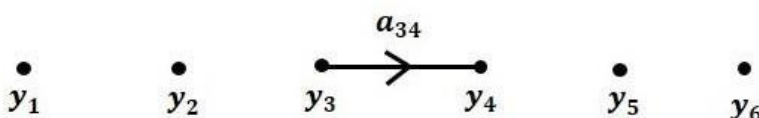

Step 4 – Signal flow graph for $y_5 = a_{45}y_4 + a_{35}y_3$ is shown in the following figure.

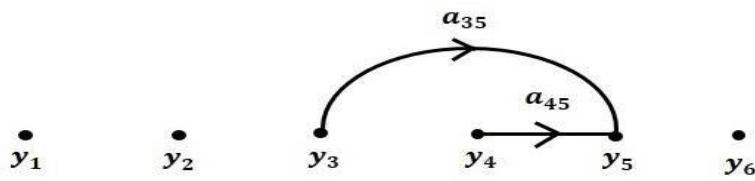

Step 5 – Signal flow graph for $y_6 = a_{56}y_5$ is shown in the following figure.



Step 6 – Signal flow graph of overall system is shown in the following figure.

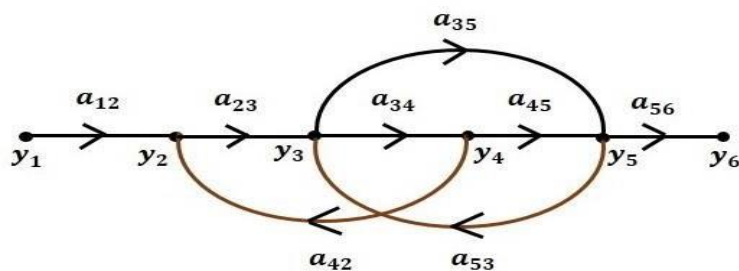

SFG from Block Diagram

The following are the steps to draw a signal flow graph:

- Represent all the signals, variables, summing points and take-off points of block diagram as nodes in signal flow graph.
- Represent the blocks of block diagram as branches in signal flow graph.
- Represent the transfer functions inside the blocks of block diagram as gains of the branches in signal flow graph.
- Connect the nodes as per the block diagram. If there is connection between two nodes (but there is no block in between), then represent the gain of the branch as one. For example, between summing points, between summing point and takeoff point, between input and summing point, between take-off point and output.
- The figure below shows a block diagram which is to be converted into the signal flow graph

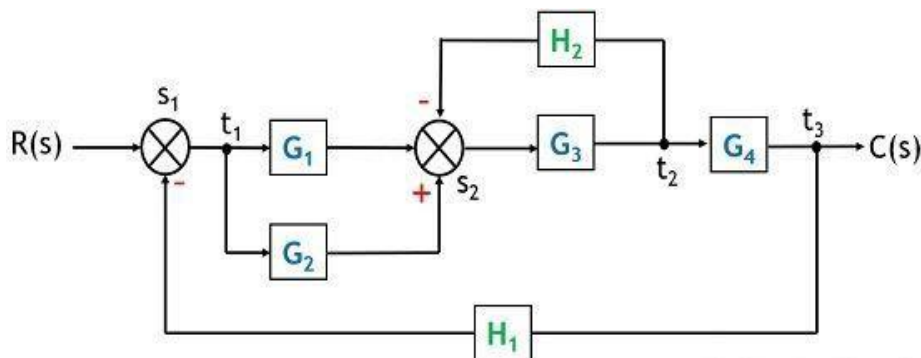

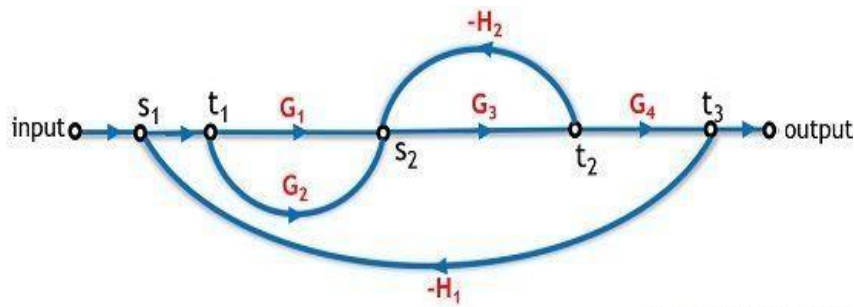

Mason's Gain formula

It is a technique used for finding the transfer function of a control system.

Basically, a formula that determines the transfer function of a linear system by making use of the signal flow graph is known as Mason's Gain Formula.

$$G(s) = \frac{C(s)}{R(s)} = \sum_{k=1}^k \frac{P_k \Delta_k}{\Delta}$$

Where,

P_k = forward path gain of the K^{th} forward path.

$\Delta = 1 - [\text{Sum of the loop gain of all individual loops}] + [\text{Sum of gain products of all possible of two non-touching loops}] + [\text{Sum of gain products of all possible three non-touching loops}] + \dots$

Δ_k = The value of Δ for the path of the graph is the part of the graph that is not touching the K^{th} forward path.

Steps for solving Signal Flow Graph

- Make a list of all forward paths, and their gains, and label these G_k .
- Make a list of all the loops and their gains, and label these L_i (for i loops). Make a list of all pairs of non-touching loops, and the products of their gains ($L_i L_j$). Make a list of all pairwise non-touching loops taken three at a time ($L_i L_j L_k$), then four at a time, and so forth, until there are no more.
- Compute the determinant Δ and cofactors Δ_k .
- Apply the formula.

Simple problems in Signal flow graph for network

Definition of Time, Stability, steady-state response, accuracy, transient accuracy, In-sensitivity and robustness, 5.2 System Time Response

If the output of control system for an input varies with respect to time, then it is called the **time response** of the control system. The time response consists of two parts.

- Transient response
- Steady state response

The response of control system in time domain is shown in the following figure.

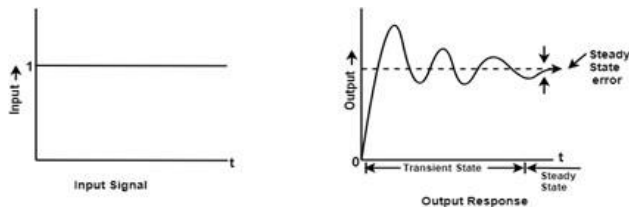

The responses corresponding to these states are known as transient and steady state responses.

Mathematically, we can write the time response $c(t)$ as

$$c(t) = c_{tr}(t) + c_{ss}(t)$$

Where,

- $c_{tr}(t)$ is the transient response
- $c_{ss}(t)$ is the steady state response

Transient Response

After applying input to the control system, output takes certain time to reach steady state. So, the output will be in transient state till it goes to a steady state. Therefore, the response of the control system during the transient state is known as transient response.

The transient response will be zero for large values of 't'. Ideally, this value of 't' is infinity and practically, it is five times constant.

Mathematically, we can write it as $\lim_{t \rightarrow \infty} c_{tr}(t) = 0$

Steady state response

The part of the time response that remains even after the transient response has zero value for large values of 't' is known as steady state response. This means, the transient response will be zero even during the steady state.

or

A **steady-state response** is the behavior of a circuit after a long time when steady conditions have been reached after an external excitation.

Sensitivity:

Sensitivity of the overall gain of negative feedback closed loop control system (**T**) to the variation in open loop gain (**G**) is defined as

$$S_G^T = \frac{\text{Percentage change in } T}{\text{Percentage change in } G} = \frac{\frac{\partial T}{T}}{\frac{\partial G}{G}} \quad \dots\dots (1)$$

Where, ∂T is the incremental change in T due to incremental change in G.

$$\text{Here } S_G^T = \frac{1}{(1+GH)}$$

sensitivity of the overall gain of closed loop control system as the reciprocal of $(1+GH)$. So, Sensitivity may increase or decrease depending on the value of $(1+GH)$.

- If the value of $(1+GH)$ is less than 1, then sensitivity increases. In this case, 'GH' value is negative because the gain of feedback path is negative.
- If the value of $(1+GH)$ is greater than 1, then sensitivity decreases. In this case, 'GH' value is positive because the gain of feedback path is positive.

In general, 'G' and 'H' are functions of frequency. So, feedback will increase the sensitivity of the system gain in one frequency range and decrease in the other frequency range.

Stability

- A system is said to be stable, if its output is under control. Otherwise, it is said to be unstable.
- Transfer function of closed loop is $T = \frac{G}{1+GH}$, if the denominator value is zero (i.e., $GH = -1$), then the output of the control system will be infinite. So, the control system becomes unstable.

Therefore, we have to properly choose the feedback in order to make the control system stable.

Robustness

- The robustness refers to the ability of a control system to withstand parameter variations in the plant transfer function, and still maintain the stability and performance goals.
- Robustness is characterized in terms of the sensitivity of the closed-loop transfer function $T(s)$ to variation in one or more of the plant parameters.

Analysis of Steady State Error

The deviation of the output of control system from desired response during steady state is known as **steady state error**. It is represented as e_{ss} .

$$e_{ss} = \lim_{t \rightarrow \infty} e(t) = \lim_{s \rightarrow 0} sE(s)$$

Consider a simple closed loop control system with negative feedback as shown figure below

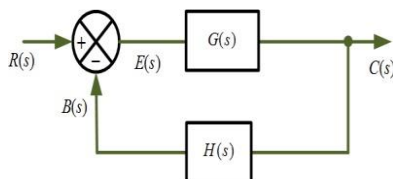

Where $R(s)$ =input signal

$B(s)$ =feedback signal

$C(s)$ =output signal

$G(s)$ =forward gain

$H(s)$ =feedback gain

$E(s)$ =error signal=difference between input $R(s)$ and feedback signal $B(s)$

Here $E(s)=R(s)-B(s)$ (1)

Also, $B(s)=C(s).H(s).....(2)$

$C(s)=E(s). G(s)(3)$

Using equation 1,2, and 3 gives

$$E(s)=R(s)- C(s).H(s)$$

$$= R(s)- E(s). G(s).H(s)$$

$$E(s)= \frac{R(s)}{1+G(s)H(s)}.....(4)$$

Steady state error is given as,

$$e_{ss}= \lim_{t \rightarrow \infty} e(t)$$

Using final value theorem,

$$e_{ss}= \lim_{s \rightarrow 0} sE(s) (5)$$

From equation 4 and equation 5 gives

$$e_{ss}= \lim_{s \rightarrow 0} \frac{sR(s)}{1+G(s)H(s)}$$

Steady state depends upon input signal $R(s)$ and open loop transfer function $G(s)H(s)$ or type of the system.

Static Error Coefficient/Constant

When a control system is excited with standard input signal the steady state error may be zero, constant or infinite. The steady state error depends on the type number and input signal.

There are 3 type of static error coefficient

- a) Positional error constant, b) Velocity error constant, c) Acceleration error constant

a) Static-Position Error Constant (or Coefficient) K_p

The steady state error is given by

$$e_{ss} = \lim_{s \rightarrow 0} s \cdot \frac{R(s)}{1+G(s)H(s)}$$

For unit step input $R(s) = \frac{1}{s}$, the steady state error is given by

$$e_{ss} = \lim_{s \rightarrow 0} s \cdot \frac{1}{s} \cdot \frac{1}{1+G(s)H(s)} = \frac{1}{1+ \lim_{s \rightarrow 0} G(s)H(s)}$$

$$e_{ss} = \frac{1}{1+K_p}$$

K_p = static position error constant = $\lim_{s \rightarrow 0} G(s)H(s)$

(b) Static Velocity Error Constant (or Coefficient) K_v

$$e_{ss} = \lim_{s \rightarrow 0} s \cdot R(s) \cdot \frac{1}{1+G(s)H(s)}$$

Steady state error with a unit ramp input is given by [$R(s) = 1/s^2$]

$$e_{ss} = \lim_{s \rightarrow 0} s \cdot \frac{1}{s^2} \cdot \frac{1}{1+G(s)H(s)}$$

$$e_{ss} = \lim_{s \rightarrow 0} \frac{1}{s + sG(s)H(s)}$$

$$= \lim_{s \rightarrow 0} \frac{1}{sG(s)H(s)}$$

$$e_{ss} = \frac{1}{K_v}$$

Where $K_v = \lim_{s \rightarrow 0} s G(s)H(s)$ static velocity error coeff.

(c) Static acceleration error constant K_a

The steady state error of the system with unit parabolic input is given by

$$R(s) = \frac{1}{s^3}$$

$$e_{ss} = \lim_{s \rightarrow 0} s \cdot \frac{1}{s^3} \cdot \frac{1}{1+G(s)H(s)} = \lim_{s \rightarrow 0} \frac{1}{s^2 + s^2G(s)H(s)}$$

$$= \lim_{s \rightarrow 0} \frac{1}{s^2G(s)H(s)} = \frac{1}{K_a}$$

Where $K_a = \lim_{s \rightarrow 0} s^2 G(s)H(s)$ = static acceleration constant.

Types of Input & Steady state Error (Step, Ramp, Parabolic) For

open loop transfer function

$$G(s)H(s) = \frac{K(1+sT_1)(1+sT_2)\dots}{s^N(1+sT_a)(1+sT_b)\dots}$$

T_1, T_2 are zeros of the system

T_a, T_b are poles of the system

The equations having a term s^N in denominator, N is the number of poles at the origin.

A system having no pole at origin of the 'S' plane, is said to be Type 0 system. i.e $N=0$

If $N=1$ i.e 'S' it means the system has a pole at origin of the S-plane and is said to be Type 1 system

A system is called Type 2 system if $N=2$ and so on.

3.4. STEADY STATE ERROR FOR DIFFERENT TYPE OF SYSTEMS

1. (a) Type zero system with unit step input

$$R(s) = \frac{1}{s}$$

From eqⁿ. 3.1

$$G(s)H(s) = \frac{K(1+sT_1)(1+sT_2)\dots}{(1+sT_a)(1+sT_b)\dots}$$

From eqⁿ. (3.6)

$$K_p = \lim_{s \rightarrow 0} G(s)H(s) = \lim_{s \rightarrow 0} \frac{K(1+sT_1)(1+sT_2)\dots}{(1+sT_a)(1+sT_b)\dots} = K$$

$$e_{ss} = \frac{1}{1+K_p} = \frac{1}{1+K} \quad \boxed{e_{ss} = \frac{1}{1+K}}$$

Hence, for type zero system the static position error constant K_p is finite.

(b) Type '0' system with unit ramp input

$$K_v = \lim_{s \rightarrow 0} s \cdot G(s)H(s) = \lim_{s \rightarrow 0} s \cdot \frac{K(1+sT_1)(1+sT_2)\dots}{(1+sT_a)(1+sT_b)\dots} = 0$$

$$\therefore e_{ss} = \frac{1}{K_v} = \infty \quad \boxed{e_{ss} = \infty}$$

(c) type '0' system with unit parabolic input

$$K_a = \lim_{s \rightarrow 0} s^2 G(s)H(s) = \lim_{s \rightarrow 0} s^2 \frac{K(1+sT_1)(1+sT_2)\dots}{(1+sT_a)(1+sT_b)\dots}$$

$$K_a = 0$$

$$\therefore e_{ss} = \frac{1}{K_a} = \infty \quad \boxed{e_{ss} = \infty}$$

For type '0' system, the steady state error is infinite for ramp and parabolic inputs. Hence, the ramp and parabolic inputs are not acceptable.

2(a) Type '1' system with unit step input ($m=1$)

$$G(s)H(s) = \frac{K(1+sT_1)(1+sT_2)\dots}{s(1+sT_a)(1+sT_b)\dots}$$

$$K_p = \lim_{s \rightarrow 0} G(s)H(s) = \lim_{s \rightarrow 0} \frac{K(1+sT_1)(1+sT_2)\dots}{s(1+sT_a)(1+sT_b)\dots} = \infty$$

$$e_{ss} = \frac{1}{1+K_p} = 0 \quad \boxed{e_{ss} = 0}$$

(b) Type '1' system with unit ramp input

$$K_v = \lim_{s \rightarrow 0} s \cdot G(s)H(s) = \lim_{s \rightarrow 0} s \cdot \frac{K(1+sT_1)(1+sT_2)\dots}{s(1+sT_a)(1+sT_b)\dots}$$

$$K_v = K$$

$$e_{ss} = \frac{1}{K_v} = \frac{1}{K} \quad \boxed{e_{ss} = \frac{1}{K}}$$

(c) Type '1' system with unit parabolic input

$$K_a = \lim_{s \rightarrow 0} s^2 G(s)H(s)$$

$$= \lim_{s \rightarrow 0} s^2 \frac{K(1+sT_1)(1+sT_2)\dots}{s(1+sT_a)(1+sT_b)\dots} = 0$$

$$\therefore e_{ss} = \frac{1}{K_a} = \infty \quad \boxed{e_{ss} = \infty}$$

Hence, from above relations for type '1' system, it is clear that for type '1' system step input and ramp inputs are acceptable and parabolic input is not acceptable.

3 (a) Type '2' system with unit step input

$$G(s)H(s) = \frac{K(1+sT_1)(1+sT_2)\dots}{s^2(1+sT_a)(1+sT_b)\dots}$$

$$K_p = \lim_{s \rightarrow 0} G(s)H(s) = \lim_{s \rightarrow 0} \frac{K(1+sT_1)(1+sT_2)\dots}{s^2(1+sT_a)(1+sT_b)\dots} = \infty$$

$$e_{ss} = \frac{1}{1+K_p} = 0 \quad \boxed{e_{ss} = 0}$$

(b) Type '2' system with unit ramp input

$$K_v = \lim_{s \rightarrow 0} sG(s)H(s)$$

$$= \lim_{s \rightarrow 0} s \cdot \frac{K(1+sT_1)(1+sT_2)\dots}{s^2(1+sT_a)(1+sT_b)\dots}$$

$$= \infty$$

$$e_{ss} = \frac{1}{K_v} = 0 \quad \boxed{e_{ss} = 0}$$

(c) Type '2' system with unit parabolic input

$$K_a = \lim_{s \rightarrow 0} s^2 G(s)H(s)$$

$$= \lim_{s \rightarrow 0} s^2 \cdot \frac{K(1+sT_1)(1+sT_2)\dots}{s^2(1+sT_a)(1+sT_b)\dots} = K$$

$$e_{ss} = \frac{1}{K_a} = \frac{1}{K} \quad \boxed{e_{ss} = \frac{1}{K}}$$

Hence, for type '2' system all three inputs (step, ramp and parabolic) are acceptable. From table 3.1, the diagonal elements are the finite values of steady state error.

Input	L (input)	Type '0'		Type '1'		Type '2'	
		Static error coeff.	e_{ss}	Static error coeff.	e_{ss}	Static error coeff.	e_{ss}
Unit step	$\frac{1}{s}$	$K_p = K$	$\frac{1}{1+K}$	$K_p = \infty$	0	$K_p = \infty$	0
Unit ramp	$\frac{1}{s^2}$	$K_v = 0$	∞	$K_v = K$	$\frac{1}{K}$	$K_v = \infty$	0
Unit parabolic	$\frac{1}{s^3}$	$K_a = 0$	∞	$K_a = 0$	∞	$K_a = K$	$\frac{1}{K}$

Parameters of first order system & second-order systems

Time Response of first order system

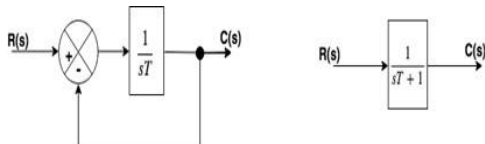

$$\frac{C(s)}{R(s)} = \frac{G(s)}{1 \pm G(s)H(s)}$$

$$\frac{\frac{1}{sT}}{1 + \frac{1}{sT} \times 1}$$

$$\text{Transfer function} = \frac{C(s)}{R(s)} = \frac{1}{1 + sT}$$

In the above transfer function, the power of 's' is the one in the denominator. That is why the above transfer function is of the first order, and the system is said to be the **first order system**.

Response of 1st order system when the input is unit step -

$$\frac{C(s)}{R(s)} = \frac{1}{(sT + 1)}$$

$$C(s) = \frac{1}{(sT + 1)} \cdot R(s)$$

For Unit Step,

$$R(S) = \frac{1}{s}$$

$$C(s) = \frac{1}{(sT+1)} \cdot \frac{1}{s}$$

Now, the partial fraction of above equation will be:

$$C(s) = \frac{1}{s} - \frac{1}{(sT+1)}$$

$$C(s) = \frac{1}{s} - \frac{1}{(s + \frac{1}{T})}$$

Taking the inverse Laplace of above equation is:

$$C(t) = 1 - e^{-\frac{t}{T}}$$

$$\text{when } t=T, \text{ so } C(t) = 1 - e^{-\frac{T}{T}}$$

$$C(t) = 1 - e^{-1} = 0.632 = 63.2\%$$

Where T is known as time constant of the system and it is defined as the time required for the signal to attain 63.2 % of final or steady state value. Time constant means how fast the system reaches the final value. As smaller the time constant, as faster is the system response. If time constant is larger, system goes to move slow.

Time response of first order system with unit ramp signal is –

$$\text{Since, input is unit ramp } R(S) = \frac{1}{s^2}$$

$$\frac{C(s)}{R(s)} = \frac{1}{sT+1}$$

$$C(s) = \frac{1}{(sT+1)} \cdot R(S)$$

Now, putting the value of R(S) in the equation

$$C(s) = \frac{1}{(sT+1)} \cdot \frac{1}{s^2}$$

$$C(s) = \frac{1}{s^2(sT+1)}$$

$$\text{Or } C(S) = \frac{1}{s^2} - \frac{T}{s} + \frac{1}{s + \frac{1}{T}}$$

Now taking the inverse Laplace of the above equation

$$\mathcal{L}^{-1}C(S) = \mathcal{L}^{-1} \frac{1}{s^2} - \mathcal{L}^{-1} \frac{T}{s} + \mathcal{L}^{-1} T \cdot \frac{1}{s + \frac{1}{T}}$$

$$C(t) = t - T + T \cdot e^{-t/T} \quad \text{For } t \geq 0$$

The error signal e (t) will be

$$e(t) = r(t) - c(t)$$

$$= t - [t - T + T \cdot e^{-t/T}]$$

$$e(t) = T [1 - e^{-t/T}]$$

$$\text{Steady state error} = \lim_{t \rightarrow \infty} (T - T \cdot e^{-t/T}) = T$$

The steady state error is equal to 'T,' where 'T' is the time constant of the system. For a small time constant, the error is small, and the response of the system increases.

Response of 1st order system with unit impulse function is –

Value of impulse = 1

$$R(s) = 1$$

$$C(s) = \frac{1}{sT+1} \cdot 1$$

$$= \frac{1}{sT+1}$$

$$= \frac{1}{T} \cdot \frac{1}{s + \frac{1}{T}}$$

Inverse Laplace

$$\mathcal{E}^{-1}C(S) = \mathcal{E}^{-1}\frac{1}{T} \cdot \mathcal{E}^{-1}\frac{1}{S + \frac{1}{T}}$$

$$C(t) = \frac{1}{T} \cdot e^{-t/T}$$

Time response of second order system

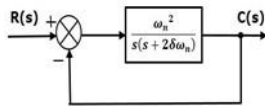

$$\frac{C(S)}{R(S)} = \frac{G(S)}{1 + G(S)H(S)}$$

$$G(S) = \frac{\omega_n^2}{s(s+2\xi\omega_n)}, \quad H(S)=1$$

$$\frac{C(S)}{R(S)} = \frac{\omega_n^2/s(s+2\xi\omega_n)}{1 + \frac{\omega_n^2}{s(s+2\xi\omega_n)}}$$

$$\frac{C(S)}{R(S)} = \frac{\omega_n^2}{s^2+2\xi\omega_n s+\omega_n^2} \dots\dots\dots(1)$$

In the above transfer function, the power of 's' is two in the denominator. That is why the above transfer function is of a second order, and the system is said to be the **second order system**.

Time response of second order system with unit step

From equation 1

$$C(S) = \frac{\omega_n^2}{s^2+2\xi\omega_n s+\omega_n^2} \cdot R(S)$$

For unit step the input is

$$R(S) = \frac{1}{s}$$

$$C(S) = \frac{1}{s} \cdot \frac{\omega_n^2}{s^2+2\xi\omega_n s+\omega_n^2}$$

$$C(S) = \frac{1}{s} \cdot \frac{\omega_n^2}{(s^2+2\xi\omega_n s+\xi^2\omega_n^2+\omega_n^2-\xi^2\omega_n^2)}$$

$$= \frac{1}{s} \cdot \frac{\omega_n^2}{(s+\xi\omega_n)^2+\omega_n^2(1-\xi^2)}$$

$$= \frac{(s+\xi\omega_n)^2+\omega_n^2(1-\xi^2)-(s+\xi\omega_n)^2+\omega_n^2\xi^2}{s\{(s+\xi\omega_n)^2+\omega_n^2(1-\xi^2)\}}$$

$$= \frac{(s+\xi\omega_n)^2+\omega_n^2(1-\xi^2)-s^2-2s\xi\omega_n-\omega_n^2\xi^2+\omega_n^2\xi^2}{s\{(s+\xi\omega_n)^2+\omega_n^2(1-\xi^2)\}}$$

$$= \frac{(s+\xi\omega_n)^2+\omega_n^2(1-\xi^2)-s(s+2s\xi\omega_n)}{s\{(s+\xi\omega_n)^2+\omega_n^2(1-\xi^2)\}}$$

$$= \frac{1}{s} - \frac{s+2s\xi\omega_n}{(s+\xi\omega_n)^2+\omega_n^2(1-\xi^2)}$$

Now putting, $\omega_d = \omega_n\sqrt{1-\xi^2}$

$$= \frac{1}{s} - \frac{s+2s\xi\omega_n}{(s+\xi\omega_n)^2+\omega_n^2(1-\xi^2)}$$

$$= \frac{1}{s} - \frac{s+\xi\omega_n}{(s+\xi\omega_n)^2+\omega_d^2} - \frac{\xi\omega_n}{(s+\xi\omega_n)^2+\omega_d^2}$$

$$\frac{1}{s} - \frac{s+\xi\omega_n}{(s+\xi\omega_n)^2+\omega_d^2} - \frac{\xi\omega_n}{\omega_d} \cdot \frac{\omega_d}{(s+\xi\omega_n)^2+\omega_d^2}$$

Delay Time

The time required for the response to reach 50% of the final value in the first time is called the delay time.

Rise Time

The time required for response to rising from 10% to 90% of final value, for an overdamped system and 0 to 100% for an underdamped system is called the rise time of the system.

Peak Time

The time required for the response to reach the 1st peak of the time response or 1st peak overshoot is called the Peak time.

Maximum overshoot

The difference between the peak of 1st time and steady output is called the maximum overshoot. It is defined by

$$\text{Maximum percent overshoot} = \frac{C(t_p) - C(\infty)}{C(\infty)}$$

$$\%M_P = e^{\frac{-\pi\xi}{\sqrt{1-\xi^2}}} \times 100$$

Settling Time (t_s)

The time that is required for the response to reach and stay within the specified range (2% to 5%) of its final value is called the settling time.

$$t_s = \frac{4}{\xi\omega_n}$$

Steady State Error (e_{ss})

The difference between actual output and desired output as time 't' tends to infinity is called the steady state error of the system.

$$e_{ss} = \lim_{t \rightarrow \infty} [r(t) - C(t)]$$

2.4.2. Location of Roots of Characteristic Equation and Time Response

The characteristic equation of

$$\frac{C(S)}{R(S)} = \frac{\omega_n^2}{s^2 + 2\xi\omega_n s + \omega_n^2}$$

is $s^2 + 2\xi\omega_n s + \omega_n^2 = 0$

The roots of eqⁿ 2.36

$$S_1 = -\xi\omega_n + j\omega_n\sqrt{1-\xi^2}$$

$$S_2 = -\xi\omega_n - j\omega_n\sqrt{1-\xi^2}$$

...(2.36)

The real part of the roots ($-\xi\omega_n$) represents the damping and imaginary part ($\omega_n\sqrt{1-\xi^2}$) represents the damped frequency.

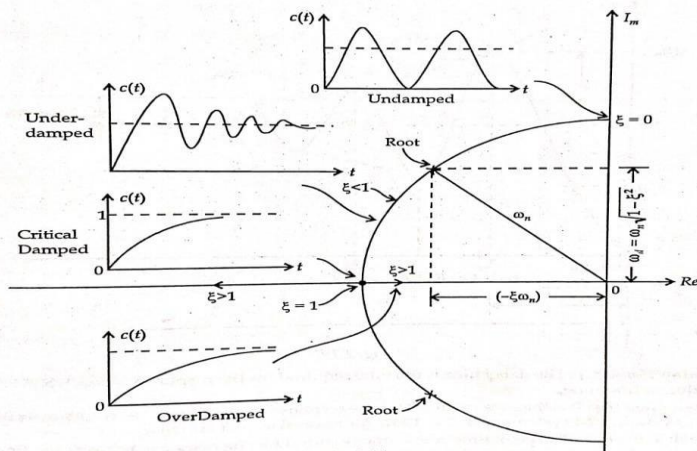

Fig. 2.16.

From the fig. 2.16

1. ω_n is the distance of root from origin.
2. $\cos \theta = \frac{\xi\omega_n}{\omega_n} = \xi$, i.e. $\theta = \cos^{-1}\xi$ (when the roots are in left-half of s-plane).
3. ω_d is the imaginary part of the root and is known as damped frequency or conditional frequency.

6. FEEDBACK CHARACTERISTICS OF CONTROL SYSTEMS

Effect of parameter variation in Open Loop System & Closed loop Systems

In control system, the feedback reduces the error, also reduces the sensitivity of the system to parameter variations. The parameter may vary due to some change in conditions. The variation in parameter affects the performance of the system. So, it is necessary to make the system in sensitive to such parameter variations.

Effect of parameter variation in Open Loop System:

The open loop control system is shown in figure below



$$\frac{C(s)}{R(s)} = G(s)$$

$$C(s) = G(s) \cdot R(s) \dots \dots \dots (1)$$

Let $\Delta G(s)$ = change in $G(s)$ due to parameter variations

$\Delta C(s)$ = corresponding change in output

From equation 1

$$C(s) + \Delta C(s) = [G(s) + \Delta G(s)]R(s)$$

$$C(s) + \Delta C(s) = G(s)R(s) + \Delta G(s)R(s)$$

Since, $G(s)R(s) = C(s)$

$$C(s) + \Delta C(s) = C(s) + \Delta G(s)R(s)$$

$$\Delta C(s) = \Delta G(s)R(s) \dots \dots \dots (2)$$

Equation 2 gives the change in output due to parameter variations in $G(s)$ in open loop system.

Effect of parameter variation in Closed Loop System:

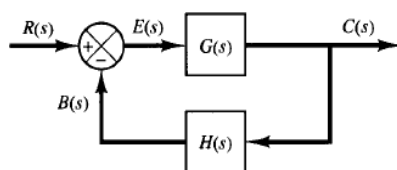

$$\frac{C(s)}{R(s)} = \frac{G(s)}{1 + G(s) \cdot H(s)}$$

$$C(s) = \frac{G(s)}{1 + G(s) \cdot H(s)} R(s)$$

$$C(s) + \Delta C(s) = \frac{G(s) + \Delta G(s)}{1 + [G(s) + \Delta G(s)] \cdot H(s)} R(s)$$

$$= \frac{G(s) + \Delta G(s)}{1 + G(s) \cdot H(s) + \Delta G(s) \cdot H(s)} R(s)$$

Since $\Delta G(s) \cdot H(s) \ll [1 + G(s)H(s)]$, neglect $\Delta G(s) \cdot H(s)$

$$C(s) + \Delta C(s) = \frac{G(s) + \Delta G(s)}{1 + G(s)H(s)} R(s)$$

$$= \frac{G(s)}{1 + G(s)H(s)} R(s) + \frac{\Delta G(s)}{1 + G(s)H(s)} R(s)$$

Since $C(s) = \frac{G(s)}{1 + G(s)H(s)} R(s)$

$$C(s) + \Delta C(s) = C(s) + \frac{\Delta G(s)}{1 + G(s)H(s)} R(s)$$

$$\Delta C(s) = \frac{\Delta G(s)}{1 + G(s)H(s)} R(s) \dots\dots\dots (2)$$

Equation 2 gives the change in output due to parameter variations in G(s) in a closed loop system.

Generally $[G(s)H(s)] \gg 1$

From equation 2 it is clear that the change in output is reduced due to parameter variations in G(s) by $[1 + G(s)H(s)]$. But in open loop system there is no reduction because of no feedback.

Introduction to Basic Control Action & Basic modes of feedback control: proportional, integral and derivative

- A controller compares the actual value of output with the reference input, determines the deviation, and produces a control signal that will reduce the deviation to zero or to a small value.

OR A controller is a device which produces a control signal that results in the reduction of the deviation of controlled output from the desired value

- The manner in which the controller produces the control signal is called the control action.

The basic function of feedback control is to compute the error as the difference between the controlled variable and the set point; calculate and then output the signal to a control valve actuator based on the error.

To perform this function, feedback control can be operated in three modes: proportional, derivative and integral.

Proportional Controller

The proportional controller produces an output, which is proportional to error signal.

$$u(t) \propto e(t)$$

$$\Rightarrow u(t) = K_p e(t)$$

Apply Laplace transform on both the sides

$$U(s) = K_p E(s)$$

$$\frac{U(s)}{E(s)} = K_p$$

Therefore, the transfer function of the proportional controller is K_p .

Where,

$U(s)$ is the Laplace transform of the actuating signal $u(t)$

$E(s)$ is the Laplace transform of the error signal $e(t)$

K_p is the proportionality constant

The block diagram of the unity negative feedback closed loop control system along with the proportional controller is shown in the following figure.

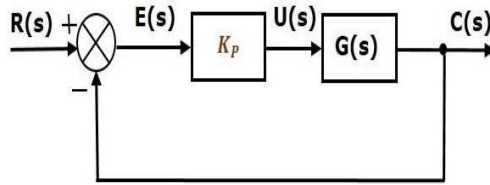

The proportional controller is used to change the transient response as per the requirement.

Derivative Controller

The derivative controller produces an output, which is derivative of the error signal.

$$u(t) = K_D \frac{de(t)}{dt}$$

Apply Laplace transform on both sides.

$$U(s) = K_D s E(s)$$

$$\frac{U(s)}{E(s)} = K_D s$$

Therefore, the transfer function of the derivative controller is $K_D s$.

Where, K_D is the derivative constant.

The block diagram of the unity negative feedback closed loop control system along with the derivative controller is shown in the following figure.

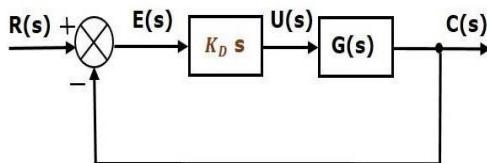

The derivative controller is used to make the unstable control system into a stable one.

Integral Controller

The integral controller produces an output, which is integral of the error signal.

$$u(t) = K_I \int e(t) dt$$

Apply Laplace transform on both the sides -

$$U(s) = \frac{K_I E(s)}{s}$$

$$\frac{U(s)}{E(s)} = \frac{K_I}{s}$$

Therefore, the transfer function of the integral controller is $\frac{K_I}{s}$

Where, K_i is the integral constant.

The block diagram of the unity negative feedback closed loop control system along with the integral controller is shown in the following figure.

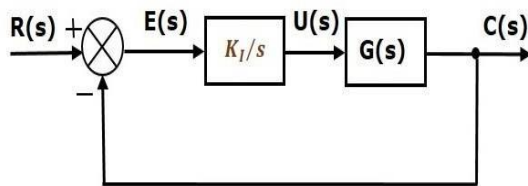

The integral controller is used to decrease the steady state error.

Now the combinations of basic controllers are

Proportional Derivative (PD) Controller

The proportional derivative controller produces an output, which is the combination of the outputs of proportional and derivative controllers.

$$u(t) = K_P e(t) + K_D \frac{de(t)}{dt}$$

Apply Laplace transform on both sides -

$$U(s) = (K_P + K_D s) E(s)$$

$$\frac{U(s)}{E(s)} = (K_P + K_D s)$$

Therefore, the transfer function of the proportional derivative controller is $K_P + K_D s$.

The block diagram of the unity negative feedback closed loop control system along with the proportional derivative controller is shown in the following figure.

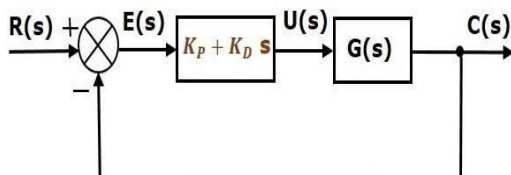

The proportional derivative controller is used to improve the stability of control system without affecting the steady state error.

Proportional Integral (PI) Controller

The proportional integral controller produces an output, which is the combination of outputs of the proportional and integral controllers.

$$u(t) = K_P e(t) + K_I \int e(t) dt$$

Apply Laplace transform on both sides

$$U(s) = \left(K_P + \frac{K_I}{s} \right) E(s)$$

$$\frac{U(s)}{E(s)} = K_p + \frac{K_I}{s}$$

Therefore, the transfer function of proportional integral controller is $K_p + \frac{K_I}{s}$.

The block diagram of the unity negative feedback closed loop control system along with the proportional integral controller is shown in the following figure.

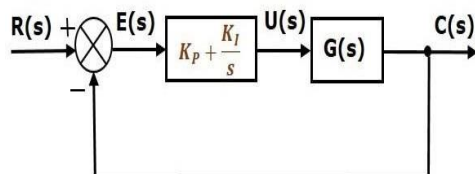

The proportional integral controller is used to decrease the steady state error without affecting the stability of the control system.

Proportional Integral Derivative (PID) Controller

The proportional integral derivative controller produces an output, which is the combination of the outputs of proportional, integral and derivative controllers.

$$u(t) = K_p e(t) + K_I \int e(t) dt + K_D \frac{de(t)}{dt}$$

Apply Laplace transform on both sides -

$$U(s) = \left(K_p + \frac{K_I}{s} + K_D s \right) E(s)$$

$$\frac{U(s)}{E(s)} = K_p + \frac{K_I}{s} + K_D s$$

Therefore, the transfer function of the proportional integral derivative controller is $K_p + \frac{K_I}{s} + K_D s$.

The block diagram of the unity negative feedback closed loop control system along with the proportional integral derivative controller is shown in the following figure.

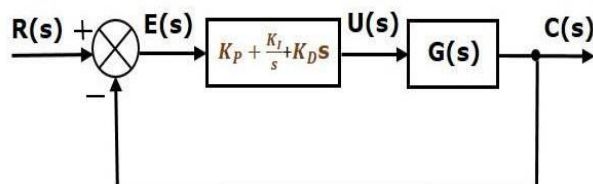

The proportional integral derivative controller is used to improve the stability of the control system and to decrease steady state error.

Effect of feedback on overall gain, Stability

Effect of feedback on overall gain



The overall transfer function of open loop system is

$$\frac{C(s)}{R(s)} = G(s)$$

The overall transfer function of closed loop system is

$$\frac{C(s)}{R(s)} = \frac{G(s)}{1+G(s)H(s)}$$

For negative feedback the gain $G(s)$ is reduced by a factor $\frac{1}{1+G(s)H(s)}$. So due to negative feedback overall gain of the system reduces.

Effect of feedback on Stability

The open loop system with overall transfer function is

$$G(s) = \frac{K}{s+T}$$

The pole is located at $s = -T$

Now, the closed loop system with unity negative feedback, then overall transfer function is given by

$$\frac{C(s)}{R(s)} = \frac{K}{s+(T+K)}$$

Now, closed loop pole is located at $s = -(T+K)$

Thus feedback controls the time response by adjusting the location of the poles. The stability depends upon the location of poles. Thus the feedback affects the stability. Feedback can improve the stability or may be harmful to stability if it is not properly design and apply.

Realisation of Controllers (P, PI, PD, PID) with OPAMP

Proportional Controller using OPAMP

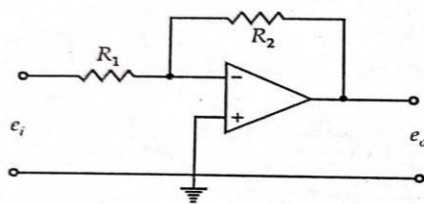

Fig. 12.64.

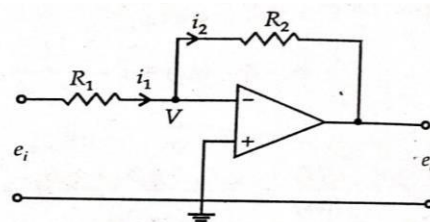

Fig. 12.64(a)

Solution :

$$i_1 = \frac{e_i - V}{R_1} \quad \text{and} \quad i_2 = \frac{V - e_o}{R_2}$$

Since $V = 0 \quad \therefore i_1 = i_2$

$$\frac{e_i}{R_1} = -\frac{e_o}{R_2}$$

Laplace transform $\frac{E_i(s)}{R_1} = -\frac{E_o(s)}{R_2}$

$$\frac{E_o(s)}{E_i(s)} = -\frac{R_2}{R_1} \quad \text{Required transfer function}$$

PI Controller using OPAMP

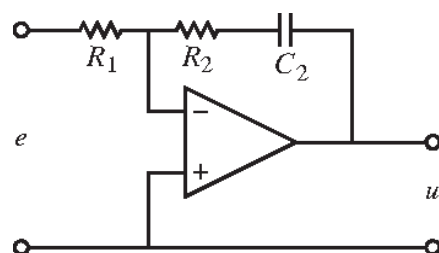

(a) PI controller

Here $\frac{U(s)}{E(s)} = \frac{R_2 C_2 S + 1}{R_1 C_2 S}$

PD Controller using OPAMP

$\frac{U(s)}{E(s)} = \frac{R_2 C_1 S}{R_1 C_1 S + 1}$

PID Controller using OPAMP

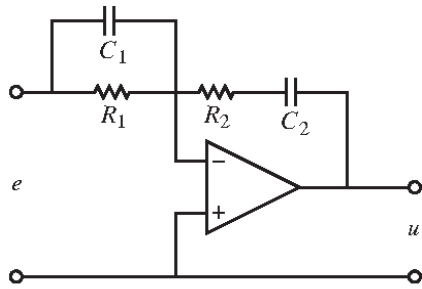

(b) PID controller

7. STABILITY CONCEPT & ROOT LOCUS METHOD

Effect of location of poles on stability

Effect of addition of poles:

- Root locus shift towards right half of the s-plane
- system stability relatively decreases
- system becomes more oscillatory in nature
- range of operating values of k, for stability of the system decreases

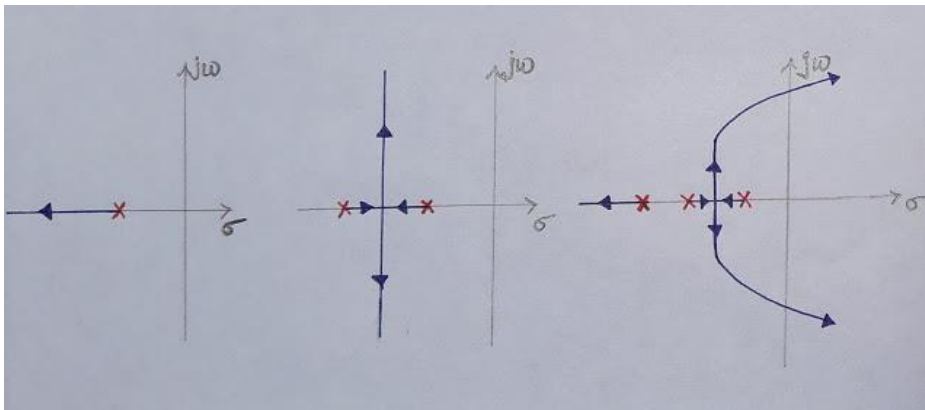

Effect of addition of zeros:

- Root locus shift towards left half of the s-plane
- system stability relatively increases
- system becomes less oscillatory in nature
- Range of operating values of K, for stability of the system increases

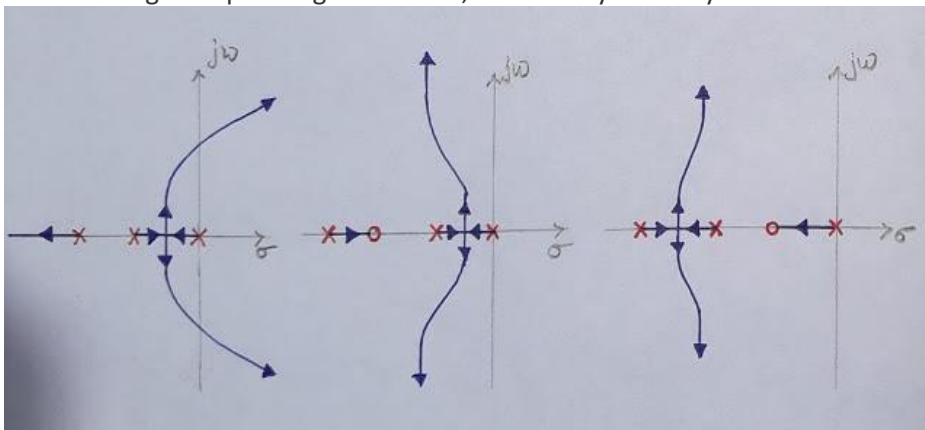

Routh Hurwitz stability criterion.

Statement of Routh-Hurwitz Criterion

Routh Hurwitz criterion states that any system can be stable if and only if all the roots of the first column have the same sign and if it does not have the same sign or there is a sign change then the number of sign changes in the first column is equal to the number of roots of the characteristic equation in the right half of the s-plane i.e. equals to the number of roots with positive real parts.

Necessary but not sufficient conditions for Stability

Consider a system with characteristic equation:

$$a_0s^m + a_1s^{m-1} + \dots + a_m = 0$$

Necessary conditions to make the system stable are

- All the coefficients of the equation should have the same sign.
- There should be no missing term.

If all the coefficients have the same sign and there are no missing terms, there is no guarantee that the system will be stable. For this, we use **Routh Hurwitz Criterion** to check the stability of the system. If the above-given conditions are not satisfied, then the system is said to be unstable.

Advantages of Routh- Hurwitz Criterion

- Find the stability of the system without solving the equation.
- Easily determine the relative stability of the system.
- Determine the range of K for stability.
- Determine the point of intersection for root locus with an imaginary axis.

Limitations of Routh- Hurwitz Criterion

- This criterion is applicable only for a linear system.
- It does not provide the exact location of poles on the right and left half of the S plane.
- In case of the characteristic equation, it is valid only for real coefficients.

The Routh- Hurwitz Criterion

Consider the following characteristic Polynomial

$$a_0s^n + a_1s^{n-1} + \dots + a_n = 0$$

When the coefficients a_0, a_1, \dots, a_n are all of the same sign, and none is zero.

Step 1: Arrange all the coefficients of the above equation in two row

Row 1	a_0	a_2	a_4
Row 2	a_1	a_3	a_5

Step 2: From these two rows, the third row will form:

Row 1	a_0	a_2	a_4
Row 2	a_1	a_3	a_5
Row 3	b_1	b_3	b_5

Where,
$$b_1 = -\frac{1}{a_1} \begin{vmatrix} a_0 & a_2 \\ a_1 & a_3 \end{vmatrix} = -\frac{a_0a_3 - a_1a_2}{a_1}$$

$$b_3 = -\frac{1}{a_1} \begin{vmatrix} a_0 & a_4 \\ a_1 & a_5 \end{vmatrix} = -\frac{a_0a_5 - a_1a_4}{a_1}$$

Step 3: Now, fourth row will form by using second and third row

Row 1	a_0	a_2	a_4
Row 2	a_1	a_3	a_5
Row 3	b_1	b_3	b_5
Row 4	c_1	c_3	c_5

Where,

$$c_1 = -\frac{1}{b_1} \begin{vmatrix} a_1 & a_3 \\ b_1 & b_3 \end{vmatrix} = -\frac{a_1 b_3 - b_1 a_3}{b_1}$$

$$c_3 = -\frac{1}{b_1} \begin{vmatrix} a_1 & a_5 \\ b_1 & b_5 \end{vmatrix} = -\frac{a_1 b_5 - b_1 a_5}{b_1}$$

Step 4: Continue this procedure of forming a new row:

Example

Check the stability of the system whose characteristic equation is given by

$$s^4 + 2s^3 + 6s^2 + 4s + 1 = 0$$

Solution

Obtain the array of coefficients as follows

s^4	1	6	1
s^3	2	4	
s^2	4	1	
s^1	3.5		
s^0			

$$b_1 = -\frac{1}{2} \begin{vmatrix} 1 & 6 \\ 2 & 4 \end{vmatrix},$$

$$b_1 = \frac{-(1 \times 4 - 2 \times 6)}{2} = \frac{-(-8)}{2} = 4$$

$$c_1 = -\frac{1}{4} \begin{vmatrix} 2 & 4 \\ 4 & 1 \end{vmatrix} = 3.5$$

$$b_2 = -\frac{1}{2} \begin{vmatrix} 1 & 1 \\ 2 & 0 \end{vmatrix} = 1$$

$$d_1 = -\frac{1}{3.5} \begin{vmatrix} 4 & 1 \\ 3.5 & 0 \end{vmatrix} = 1$$

Since all the coefficients in the first column are of the same sign, i.e., positive, the given equation has no roots with positive real parts; therefore, the system is said to be stable.

Steps for Root locus method

ROOT LOCUS

- Root locus is a graphical method in which roots of the characteristic equation are plotted in s-plane for the different values of parameter.
- The locus of the roots of the characteristic equation when gain is varied from zero to infinity is called root locus.

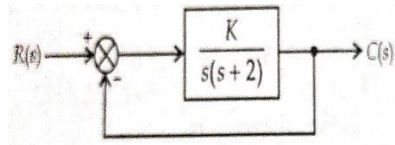

Consider a unity feedback system, the characteristic equation $1+G(s)H(s)=0$(1)

Here $G(s)=\frac{K}{s(s+2)}$ and $H(s)=1$

So equation become

$$1 + \frac{K}{s(s+2)} \cdot 1 = 0$$

$$s^2 + 2s + K = 0 \dots\dots\dots(2)$$

The root of equation 2 are

$$s_1 = -1 + \sqrt{1 - K}, s_2 = -1 - \sqrt{1 - K}$$

As K is varied, the two roots give the locii in s-plane. For various values of K, the location of the roots is

1. When $K=0$, the two roots are $s_1 = 0$ and $s_2 = -2$. These are also open loop poles
2. When $K=1$, $s_1 = s_2 = -1$. These roots are real and equal
3. When $K=2$ ($K>1$), $s_1 = -1+j$ and $s_2 = -1-j$. These are complex conjugate with real part=-1

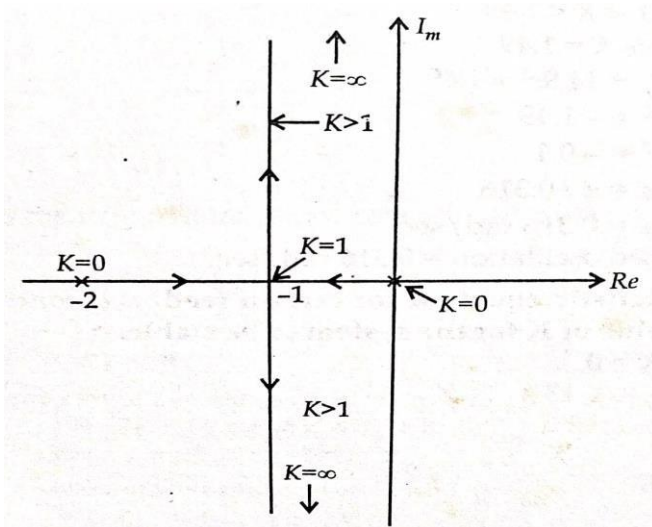

Rules for Construction of Root Loci

1. Starting point:

The root locii starts from an open loop pole with $K=0$

2. Ending point:

The root locii will terminate either on an open loop zeros or on infinity with $K=\infty$

3. Number of branches:

The number of branches of the root locus are

$$N=P \text{ if } P>Z$$

$$N=Z \text{ if } Z>P$$

Usually, $P>Z$, therefore, $N=P$

4. Existence on real axis:

The existence of the root locus on a section of real axis is confirmed if the sum of the open loop poles and zeros to the right of the section is odd.

5. The angle of Asymptotes:

The branches of root locus tend to infinity along a set of straight line called asymptotes. These asymptotes making an angle with real axis and is given by

$$\Phi = \frac{(2K+1)180^\circ}{P-Z} \text{ where } K= 0,1,2,\dots \text{ up to } (P-Z)-1$$

6. Centroid of Asymptotes:

The point of intersection of asymptotes with real axis is called Centroid of asymptotes(σ_A) and is given by

$$\sigma_A = \frac{\sum \text{Poles} - \sum \text{Zeros}}{P-Z}$$

7. Break away point:

- If the root locus lies between two adjacent open loop poles on the real axis then there will be at least one breakaway point, because the roots move towards each other as K is increased and meet at a point. At this point K is maximum. If increase the value of K between two poles the root locus breaks in two parts.
- Similarly, if root locus lies between two adjacent zeros on real axis, then there will be at least one break in point. If the root locus lies between an open loop pole and zero, then there will be no breakaway or break in point or may be both occur.
- The breakaway or break in points can be determined from the roots of

$$\frac{dK}{ds} = 0$$

8. Angle of Departure and Angle of Arrival of the root locii:

- The angle of departure of the root locus from a complex pole is given by

$$\Phi_d = 180^\circ - (\Phi_p - \Phi_z)$$

The angle of departure is tangent to the root locus at the complex pole

- The angle of arrival of the root locus at a complex zero is given by

$$\Phi_a = 180^\circ - (\Phi_z - \Phi_p)$$

The angle of arrival is tangent to the root locus at the complex zero

Where

Φ_p is the sum of all the angles subtended by remaining poles.

Φ_z is the sum of all angles subtended by zeros.

9. Intersection points with imaginary axis:

The intersection of root locus branches with $j\omega$ axis can be determined through Routh Hurwitz criterion.

Root locus method of design (Simple problem)

9. STATE VARIABLE ANALYSIS

- State Space analysis (also known as state variable analysis) is a commonly used method nowadays for analyzing the control system. The analysis that involves providing a complete idea about the behavior of the system at any given time utilizing the history of the system is known as state-space analysis.

OR

The process by which the state of a system is determined is called state variable analysis.

- State space analysis is an excellent method for the design and analysis of control systems. The conventional and old method for the design and analysis of control systems is the transfer function method. The transfer function method for design and analysis had many drawbacks.

Drawbacks of transfer function analysis.

- Transfer function is defined under zero initial conditions.
- Transfer function approach can be applied only to linear time invariant systems.
- It does not give any idea about the internal state of the system.
- It cannot be applied to multiple input multiple output systems.
- It is comparatively difficult to perform transfer function analysis on computers.

Advantages of State Space Techniques

- This technique can be used for linear or nonlinear, time-variant or time-invariant systems.
- It is easier to apply where Laplace transform cannot be applied.
- The n th order differential equation can be expressed as ' n ' equation of first order.
- It is a time domain method.
- As this is time domain method, therefore this method is suitable for digital computer computation.
- On the basis of the given performance index, this system can be designed for an optimal condition.

Concepts of state, state variable, state model,

State

It refers to smallest set of variables whose knowledge at $t = t_0$ together with the knowledge of input for $t \geq t_0$ gives the complete knowledge of the behavior of the system at any time $t \geq t_0$.

OR

It is a group of variables, which summarizes the history of the system in order to predict the future values (outputs).

State Variables

It refers to the smallest set of variables which help us to determine the state of the dynamic system. State variables are defined by $x_1(t), x_2(t), \dots, X_n(t)$.

OR

The number of the state variables required is equal to the number of the storage elements present in the system.

Examples – current flowing through inductor, voltage across capacitor

State space model

Consider a system having a inputs, b outputs and c state variables. Then,

Output variables = $Y_1(t), Y_2(t), Y_3(t) \dots Y_b(t)$

Input variables = $U_1(t), U_2(t), U_3(t) \dots U_a(t)$

State variables = $X_1(t), X_2(t), X_3(t) \dots X_c(t)$

Then the system can be represented as shown below.

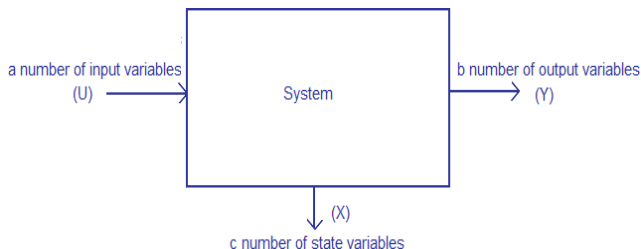

The **state space model** of Linear Time-Invariant (LTI) system can be represented as,

$$\dot{X} = AX + BU$$

$$Y = CX + DU$$

The first and the second equations are known as state equation and output equation respectively.

Where,

- X and \dot{X} are the state vector and the differential state vector respectively.
- U and Y are input vector and output vector respectively.
- A is the system matrix.
- B and C are the input and the output matrices.
- D is the feed-forward matrix.

state models for linear continuous time functions(Simple)

We know that state variables show variation with time. Thus writing the differential equation of the state variable, we will have

$$\frac{dx_1(t)}{dt} = \dot{x}_1(t) = a_{11}x_1(t) + a_{12}x_2(t) + b_{11}u_1(t) + b_{12}u_2(t)$$

$$\frac{dx_2(t)}{dt} = \dot{x}_2(t) = a_{21}x_1(t) + a_{22}x_2(t) + b_{21}u_1(t) + b_{22}u_2(t)$$

Thus the matrix representation will be given as:

$$\begin{bmatrix} \dot{x}_1(t) \\ \dot{x}_2(t) \end{bmatrix} = \begin{bmatrix} a_{11} & a_{12} \\ a_{21} & a_{22} \end{bmatrix} \begin{bmatrix} x_1(t) \\ x_2(t) \end{bmatrix} + \begin{bmatrix} b_{11} & b_{12} \\ b_{21} & b_{22} \end{bmatrix} \begin{bmatrix} u_1(t) \\ u_2(t) \end{bmatrix}$$

Therefore, the generalized form:

$$\dot{X}(t) = AX(t) + BU(t)$$

• Output Equation

The output of the system will be represented as the linear combination of the state of the system and the applied input. Thus is given as:

$$y_1(t) = c_{11}x_1(t) + c_{12}x_2(t) + d_{11}u_1(t) + d_{12}u_2(t)$$

$$y_2(t) = c_{21}x_1(t) + c_{22}x_2(t) + d_{21}u_1(t) + d_{22}u_2(t)$$

The coefficients c and d taken over here are constants. Thus writing the above equation in the form of a matrix, we will have:

$$\begin{bmatrix} y_1(t) \\ y_2(t) \end{bmatrix} = \begin{bmatrix} c_{11} & c_{21} \\ c_{12} & c_{22} \end{bmatrix} \begin{bmatrix} x_1(t) \\ x_2(t) \end{bmatrix} + \begin{bmatrix} d_{11} & d_{21} \\ d_{12} & d_{22} \end{bmatrix} \begin{bmatrix} u_1(t) \\ u_2(t) \end{bmatrix}$$

Therefore, in general form, we can write it as

$$Y(t) = C X(t) + D U(t)$$

Thus the two equations combinedly form the state model of the linear system:

$$X'(t) = A X(t) + B U(t)$$

$$Y(t) = C X(t) + D U(t)$$

Example 1

A system is described by the differential equation

$$\frac{d^3y}{dt^3} + 6\frac{d^2y}{dt^2} + 11\frac{dy}{dt} + 10y = 8u(t)$$

Where y is the output and u is the input to the system. Obtain the state space representation of the system.

Solution

$x_1 = y$, $x_2 = \dot{y}$ and $x_3 = \ddot{y}$ then

$$\begin{aligned} \dot{x}_1 &= x_2 \\ \dot{x}_2 &= x_3 \\ \dot{x}_3 &= 8u(t) - 10x_1 - 11x_2 - 6x_3 \end{aligned}$$

And the last equation will be

$$\begin{bmatrix} \dot{x}_1 \\ \dot{x}_2 \\ \dot{x}_3 \end{bmatrix} = \begin{bmatrix} 0 & 1 & 0 \\ 0 & 0 & 1 \\ -10 & -11 & -6 \end{bmatrix} \begin{bmatrix} x_1 \\ x_2 \\ x_3 \end{bmatrix} + \begin{bmatrix} 0 \\ 0 \\ 8 \end{bmatrix} u(t)$$

Now comparing Eq.6 and above equation

$$A = \begin{bmatrix} 0 & 1 & 0 \\ 0 & 0 & 1 \\ -10 & -11 & -6 \end{bmatrix}, \quad B = \begin{bmatrix} 0 \\ 0 \\ 8 \end{bmatrix}, \quad x(t) = \begin{bmatrix} x_1 \\ x_2 \\ x_3 \end{bmatrix}$$