**GOVERNMENT POLYTECHNIC
BHUBANESWAR**



**LECTURE NOTES
ON
ENERGY CONVERSION-I
(TH-1)
SEM:4TH SEM**

Department of Electrical Engineering

PREPARED BY- AMIT KUMAR BISOYI (GUEST FACULTY)

DC GENERATOR

Operating Principle Of D Generator:

An electric generator is a machine that converts mechanical energy into electrical energy. An electric generator is based on the principle that whenever flux is cut by a conductor, an e.m.f. is induced which will cause a current to flow if the conductor circuit is closed. The direction of induced e.m.f. (and hence current) is given by Fleming's Right hand rule.

Fleming's Right hand rule:

Statement: The thumb, fore finger and middle finger of the right hand are stretched to be perpendicular to each other and if the thumb represents the direction of the movement of conductor, fore-finger represents direction of the magnetic field, then the middle finger represents direction of the induced emf.

Simple Loop Generator:

Consider a single turn loop ABCD rotating clockwise in a uniform magnetic field as shown in Fig.1(a). As the loop rotates, the flux linking the coil sides AB and CD changes continuously. Hence the e.m.f. induced in these coil sides also changes but the e.m.f. induced in one coil side adds to that induced in the other.

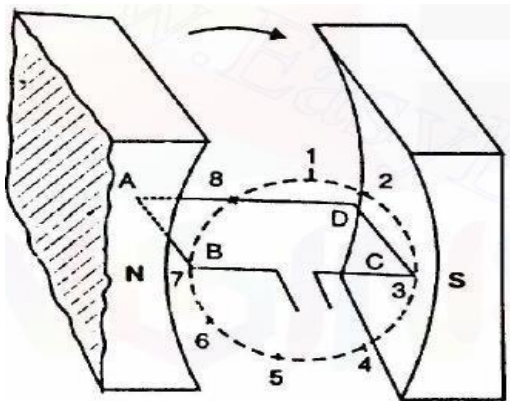

Fig: 1(a)

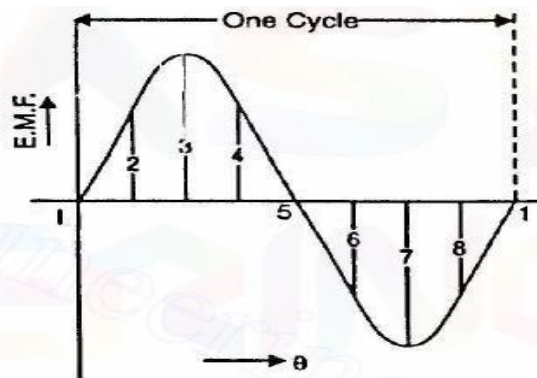

Fig: 1(b)

- I. When the loop is in position no. 1, the generated e.m.f. is zero because the coil sides (AB and CD) are cutting no flux but are moving parallel to it.
- II. When the loop is in position no. 2, the coil sides are moving at an angle to the flux and, therefore, a low e.m.f. is generated as indicated by point 2 in Fig.1(b).
- III. When the loop is in position no. 3, the coil sides (AB and CD) are at right angle to the flux and are, therefore, cutting the flux at a maximum rate. Hence at this instant, the generated e.m.f. is maximum as indicated by point 3 in Fig. 1(b).
- IV. At position 4, the generated e.m.f. is less because the coil sides are cutting the flux at an angle.
- V. At position 5, no magnetic lines are cut and hence induced e.m.f. is zero as indicated by point 5 in Fig.1(b).

- VI. At position 6, the coil sides move under a pole of opposite polarity and hence the direction of generated e.m.f. is reversed. The maximum e.m.f. in this direction (i.e., reverse direction) will be when the loop is at position 7 and zero when at position 1. This cycle repeats with each revolution of the coil.

Therefore e.m.f. generated in the loop is alternating one. The alternating voltage generated in the loop can be converted into direct voltage by a device called commutator. A commutator is also called a mechanical rectifier.

Commutator consists of a cylindrical metal ring cut into two halves or segments C1 and C2 respectively separated by a thin sheet of mica. The ends of coil sides AB and CD are connected to the segments C1 and C2 respectively as shown in Fig.1(c). Two stationary carbon brushes rest on the commutator and lead current to the external load.

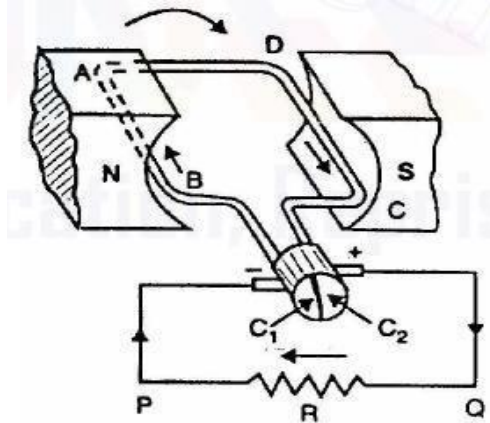

Fig:1(c)

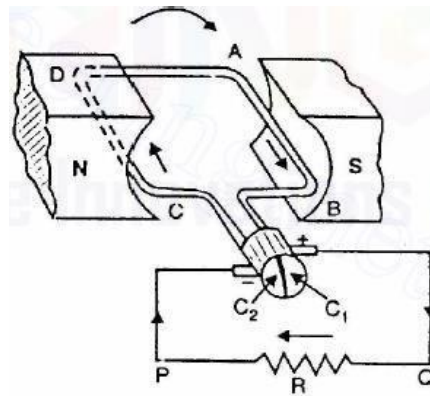
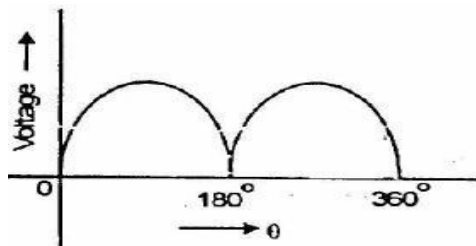

Fig:1(d)

- i. In Fig.1(c), the coil sides AB and CD are under N-pole and S-pole respectively. The commutator at all times connects the coil side under S-pole to the +ve brush and that under N-pole to the -ve brush. The segment C1 connects the coil side AB to point P of the load resistance R and the segment C2 connects the coil side CD to point Q of the load. The direction of current through load is from Q to P.
- ii. After half a revolution of the loop (i.e., 180° rotation), the coil side AB is under S-pole and the coil side CD under N-pole as shown in Fig.1(d). The currents in the coil sides now flow in the reverse direction but the segments C1 and C2 have also moved through 180° i.e., segment Q is now in contact with +ve brush and segment C2 in contact with -ve brush. The commutator has reversed the coil connections to the load i.e., coil side AB is now connected to point Q of the load and coil side CD to the point P of the load. The direction of current through the load is from Q to P.

Thus the alternating voltage generated in the loop will appear as direct voltage across the brushes by the use of commutator. The purpose of brushes is simply to lead current from the rotating loop or winding to the external stationary load.



Construction of Dc Machine:

The dc generators and dc motors have the same general construction.

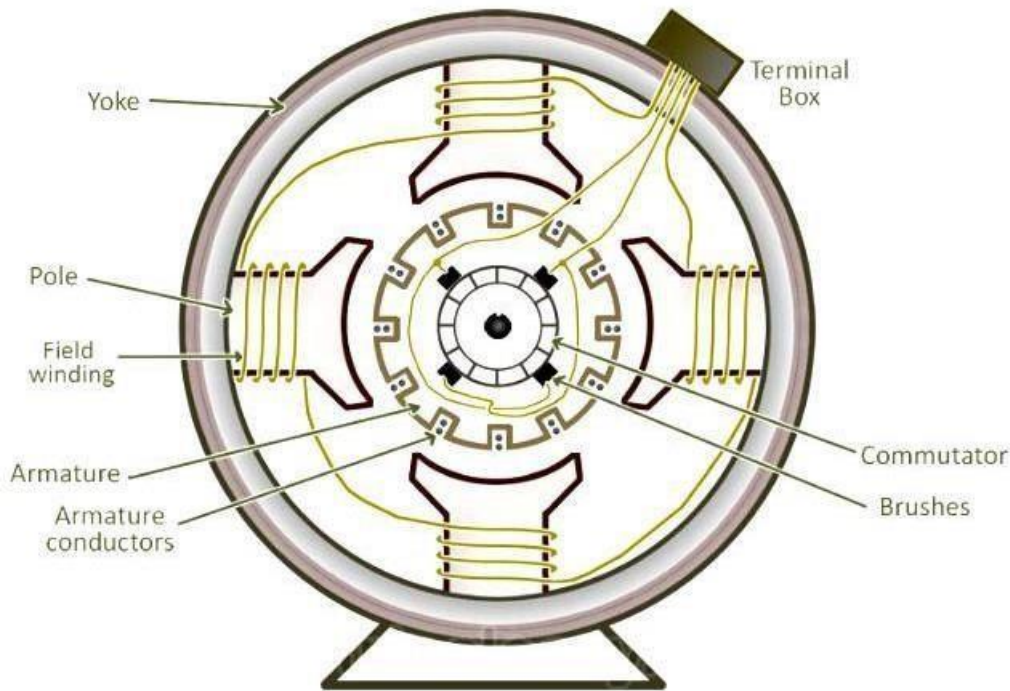

A DC machine consists two basic parts;

- **stator**- A stator is the static part of the DC machine that houses the field windings and receives the supply.
- **rotor**-A rotor is the rotating part of the DC machine that brings about the mechanical rotations. The armature is rotating part of the machine.

Basic constructional parts of a DC machine are described below

1. **Yoke:** The outer frame of a dc machine is called as yoke. It is made up of cast iron or steel. It not only provides mechanical strength to the whole assembly but also carries the magnetic flux produced by the field winding.
2. **Pole Core and Pole Shoes:** The Pole Core and Pole Shoes are fixed to the magnetic frame or yoke by bolts. Poles are joined to the yoke with the help of bolts or welding. They carry field winding and pole shoes are fastened to them. The pole shoes serve two purposes:
 - They spread out the flux in the air gap and also, being of larger cross-section, reduce the reluctance of the magnetic path
 - They support the exciting coils (or field coils)

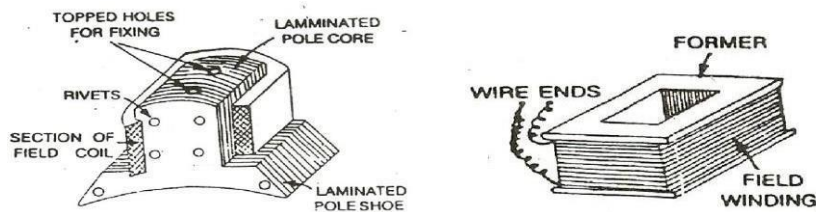

3. **Field or Exciting Coils :** They are usually made of copper. Field coils are former wound and placed on each pole. When direct current passes through the field winding, it magnetizes the poles, which in turns produces the flux.The field coils of all the poles are connected in series in such a way that when current flows through them, they form alternate North and South poles.

4. **Armature core:** The rotating part of the DC machine is called the Armature. Armature core is the rotor of a dc machine. It is cylindrical in shape with slots to carry armature winding. The armature core is made of thin laminated circular silicon steel disks for reducing eddy current losses. The armature core of a DC machine serves the following purposes.
- It houses the conductors in the slots.
 - It provides an easy path for the magnetic flux.

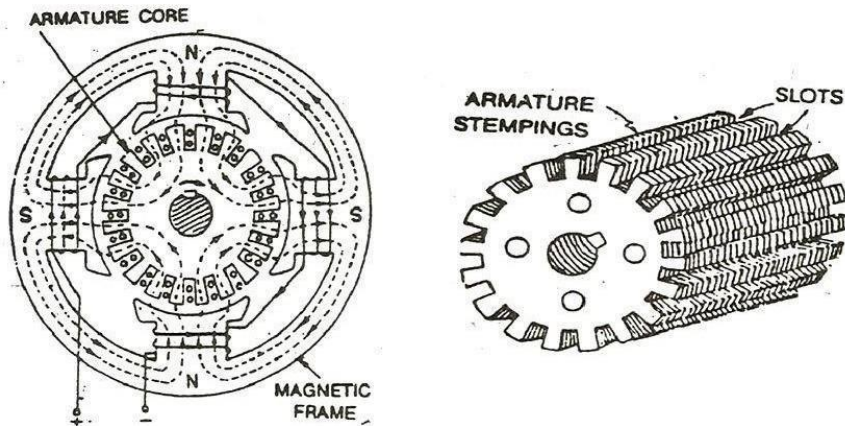

5. **Armature Winding:** It is usually a former wound copper coil which rests in armature slots. The armature conductors are insulated from each other and also from the armature core. Armature winding can be wound by one of the two methods; lap winding or wave winding. Double layer lap or wave windings are generally used. A double layer winding means that each armature slot will carry two different coils.

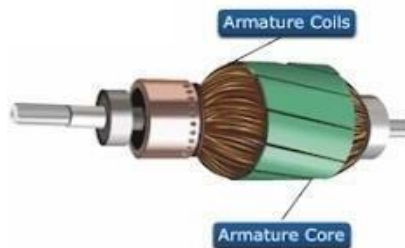

6. **Commutator:** The commutator, which rotates with the armature, is cylindrical in shape and is made from a number of wedge-shaped hard drawn copper bars or segments insulated from each other by a thin sheet of mica. The segments form a ring around the shaft of the armature. Each commutator segment is connected to the ends of the armature coils.

It is the most important part of a DC machine and serves the following purposes. ➤ It connects the rotating armature conductors to the stationary external circuit through brushes.

- It converts the induced alternating current in the armature conductor into unidirectional current in the external load circuit in DC Generator action, whereas it converts the alternating torque into unidirectional (continuous) torque produced in the armature in motor action.

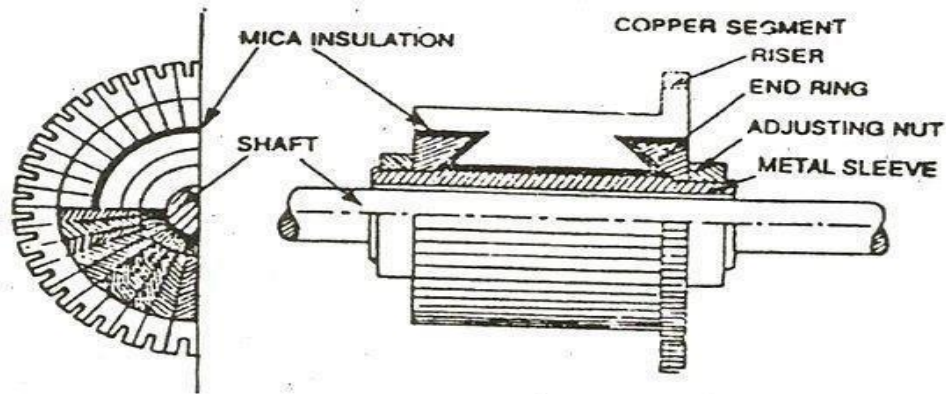

7. **Brushes:** Carbon brushes are placed or mounted on the commutator and with the help of two or more carbon brushes current is collected from the armature winding. Each brush is supported in a metal box called a brush box or brush holder. The brushes are pressed upon the commutator and form the connecting link between the armature winding and the external circuit. They are usually made of high-grade carbon because carbon is conducting material and it provides a lubricating effect on the commutator surface.
8. **Bearings:** The ball or roller bearings are fitted in the end housings. The function of the bearings is to reduce friction between the rotating and stationary parts of the machine. Mostly high carbon steel is used for the construction of bearings as it is very hard material.
9. **Shaft:** The shaft is made of mild steel with a maximum breaking strength. The shaft is used to transfer mechanical power from or to the machine. The rotating parts like armature core, commutator are mounted to the shaft.

Armature Winding Terminology:

Conductor: Each individual length of wire lying in the magnetic field is called conductor.

Turn: When the two conductors lying in the magnetic field are connected in series, so that the emf induced in them help each other or the resultant induced emf becomes double of that due to one conductor is called turn.

Coil: When one or more turns are connected in series and two ends of it are connected to the adjacent commutator segments it is called a coil.

Pole Pitch: The pole pitch is defined as distance is measured in term of armature slots or armature conductors per pole. Pole Pitch is naturally equal to the total number of armature slots divided by the number of poles in the machine.

If there are 96 slots on the armature periphery and 4 numbers of poles in the machine, the numbers of armature slots come between two adjacent poles centres would be $96/4 = 24$. Hence, the pole pitch of that DC machine would be 24.

Coil Span: The pole pitch is defined as distance is measured in term of armature slots or armature conductors spanned by a coil.

If the coil span is equal to the pole pitch, then the armature winding is said to be full - pitched. In this situation, two opposite sides of the coil lie under two opposite poles. Hence emf induced in one side of the coil will be in 180° phase shift with emf induced in the other side of the coil. Thus, the total terminal

voltage of the coil will be the arithmetic sum of these two emfs. If the coil span is less than the pole pitch, then the winding is referred as fractional pitched. In this coil, there will be a phase difference between induced emf in two sides, less than 180° . Hence resultant terminal voltage of the coil is vector sum of these two emf's and it is less than that of full-pitched coil.

Back Pitch (Y_B): It is defined as the distance in terms of number of armature conductors between the last and the first conductor of the coil. It is also called as coil span or spread. It is represented by Y_B .

Front Pitch (Y_F): It is defined as the distance in terms of number of armature conductors between the second conductor of one coil and the first conductor of next coil which is connected to the same commutator segment. It is represented by Y_F .

Resultant Pitch (Y_R): It is the distance between the beginning of one coil and the beginning of the next coil to which it is connected. It is represented by Y_R .

Commutator Pitch (Y_C): Commutator pitch is defined as the distance between two commutator segments which two ends of same armature coil are connected. It is represented by Y_C .

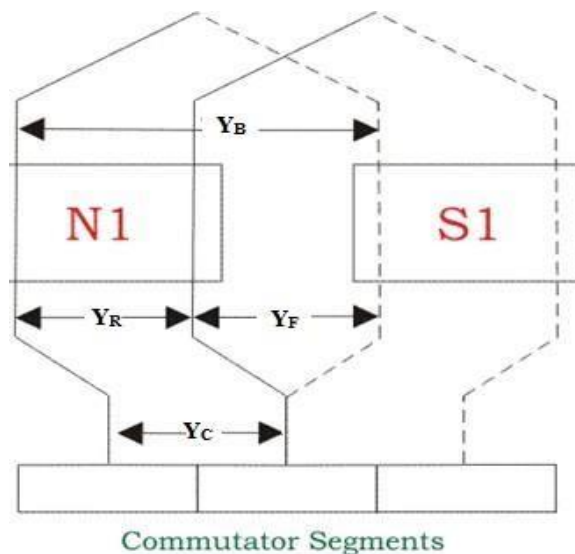

Armature Winding of A DC Machine:

Based on type of winding connections, the armature winding of a dc machine are of two types. These winding connections are same for DC generator & DC motor.

Types of Armature Windings in DC Machine,

1. Lap winding.
2. Wave winding.

Lap winding of a DC Machine

In this type of winding the completing end of one coil is connected to a commutator segment and to the start end of adjacent coil located under the same pole and similarly all coils are connected. This type of winding is known as lap because the sides of successive coils overlap each other.

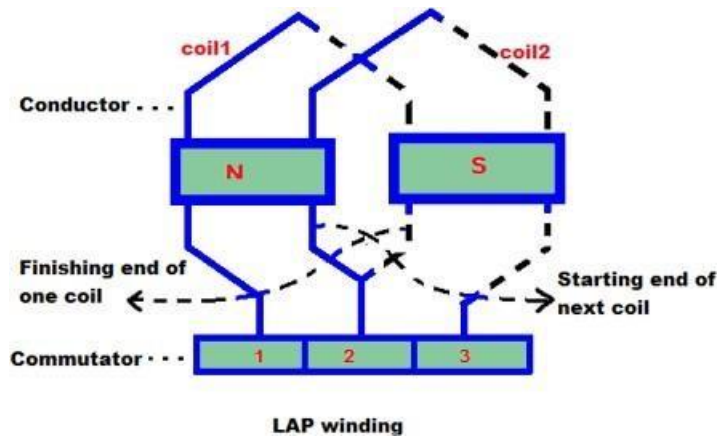

Lap winding may be simplex (single) or multiplex (duplex or triplex) winding. In simplex lap winding the connection of the winding is that there are as many parallel paths as there are number of poles. Whereas for duplex, the number of parallel paths are equal to twice that of the number of poles and for triplex it is thrice. For this reason, the lap winding is called multiple or parallel winding. The purposes of such type of windings are,

- a. To increase the number of parallel paths enabling the armature current to increase i.e., for high current output.
- b. To improve commutation as the current per conductor decreases.

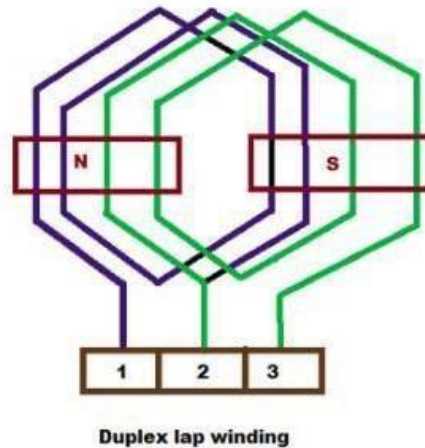
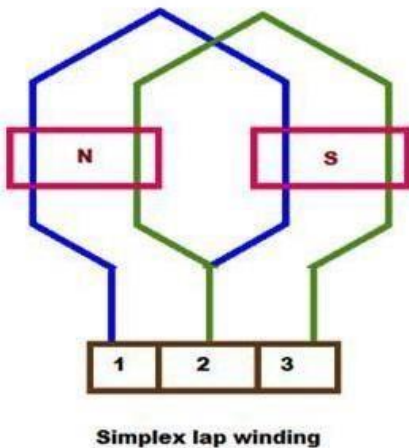

Wave winding of a DC Machine

In wave winding the coils which are carrying current in one direction are connected in series circuit and the carrying current in opposite direction are connected in another series circuit. In wave winding, the conductors are so connected that they are divided into two parallel paths irrespective of the number of poles of the machine. Thus, if the machine has Z armature conductors, there will be only two parallel paths each having $Z/2$ conductors in series. In this case number of brushes is equal to two, i.e. number of parallel paths.

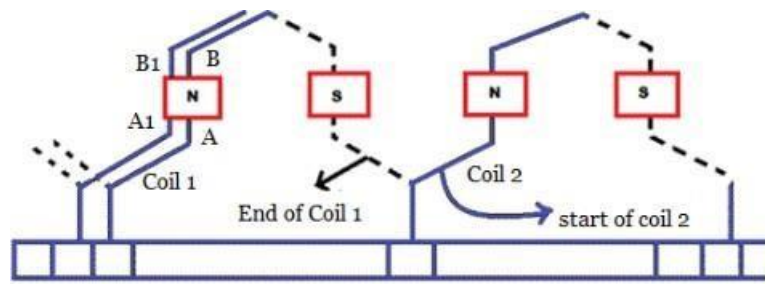

Wave Winding

If after passing once around the armature the winding falls in a slot to the left of its starting point then winding is said to be retrogressive. If it falls one slot to the right it is progressive.

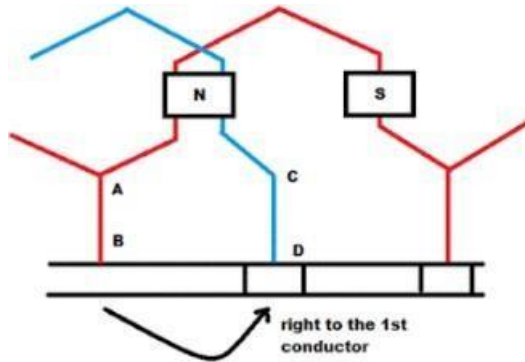

Progressive Wave winding

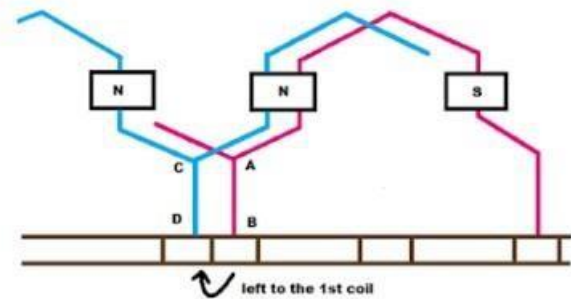

Retrogressive wave winding

Emf Equation of a DC Generator:

As the armature rotates, a voltage is generated in its coils. In the case of a generator, the emf of rotation is called the Generated emf or Armature emf and is denoted as E_g . In the case of a motor, the emf of rotation is known as Back emf or Counter emf and represented as E_b . The expression for emf is same for both the operations. i.e., for Generator as well as for Motor

Derivation of EMF Equation of a DC Machine

Let,

P = Number of poles of the machine

ϕ = Flux per pole in Weber.

Z = Total number of armature conductors.

N = Speed of armature in revolution per minute (r.p.m).

A = Number of parallel paths in the armature winding.

In one revolution of the armature, the flux cut by one conductor is given as

$$\text{Flux cut by one conductor} = P\phi \text{ wb} \dots \dots (1)$$

Time taken to complete one revolution is given as

$$t = \frac{60}{N} \text{ seconds} \dots \dots (2)$$

Therefore, the average induced e.m.f in one conductor will be

$$e = \frac{P\phi}{t} \dots \dots (3)$$

Putting the value of (t) from Equation (2) in the equation (3) we will get

$$e = \frac{P\phi}{60/N} = \frac{P\phi N}{60} \text{ volts} \dots\dots\dots (4)$$

The number of conductors connected in series in each parallel path = Z/A.

Therefore, the average induced e.m.f across each parallel path or the armature terminals is given by the equation

$$E = \frac{P\phi N}{60} \times \frac{Z}{A} = \frac{PZ\phi N}{60 A} \text{ volts or}$$

$$E = \frac{PZ\phi n}{A} \dots\dots\dots (5)$$

Where n is the speed in revolution per second (r.p.s) and given as

$$n = \frac{N}{60}$$

For a given machine, the number of poles and the number of conductors per parallel path (Z/A) are constant. Hence induced emf equation can be written as

$$E \propto \phi N \quad \text{or}$$

$$E \propto \phi \omega$$

Where ω is the angular velocity in radians/second is represented as

$$\omega = \frac{2\pi N}{60}$$

Thus, it is clear that the induced emf is directly proportional to the speed and flux per pole. The polarity of induced emf depends upon the direction of the magnetic field and the direction of rotation. If either of the two is reverse the polarity changes, but if two are reversed the polarity remains unchanged.

If the machine DC Machine is working as a **Generator**, the induced emf is given by the equation

$$E_g = \frac{PZ \phi N}{60 A} \text{ volts}$$

Where E_g is the Generated Emf

If the machine DC Machine is working as a **Motor**, the induced emf is given by the equation

$$E_b = \frac{PZ \phi N}{60 A} \text{ volts}$$

In a motor, the induced emf is called **Back Emf** (E_b) because it acts opposite to the supply voltage.

Types of D.C Generators:

Generators are generally classified according to their methods of field excitation. On this basis, d.c. generators are divided into the following two classes:

- i. Separately excited d. c generators
- ii. Self-excited d. c generators

Separately excited d. c. generators: Separately-excited generators are those whose field magnets are energized from an independent external source of DC current. The flux produced by the poles depends upon the field current with the unsaturated region of magnetic material of the poles. i.e. flux is directly proportional to the field current. But in the saturated region, the flux remains constant.

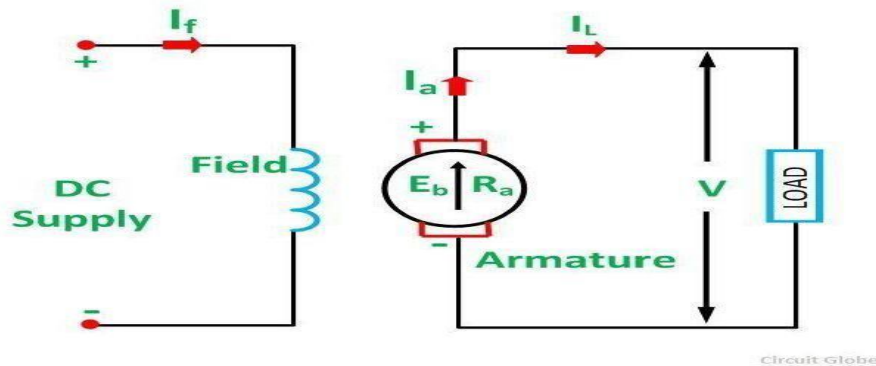

Armature current, $I_a = I_L$
 Terminal voltage, $V = E_g - I_a R_a$
 Electric power developed = $E_g I_a$
 Power delivered to load = $E_g I_a - I_a^2 R_a = I_a (E_g - I_a R_a) = V I_a$

Self-excited d.c generators: Self-excited generators are those whose field magnets are energized by the current produced by the generators themselves. There are three types of self-excited generators depending upon the manner in which the field winding is connected to the armature, namely;

- i. Series generator;
- ii. Shunt generator;
- iii. Compound generator

Series generator:

In this case, the field windings are connected in series with the armature windings. The series field winding carries the armature current. The series field winding consists of a few turns of wire of thick wire of larger cross-sectional area and having low resistance usually of the order of less than 1 ohm because the armature current has a very large value.

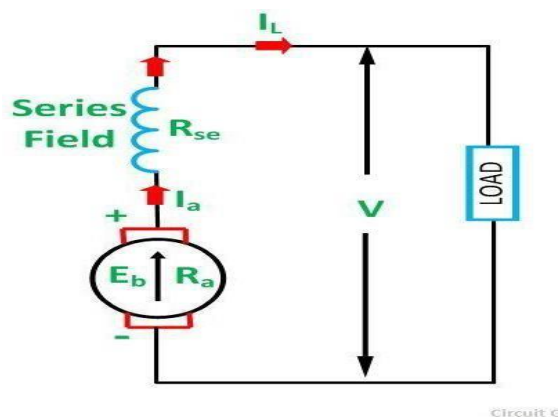

Armature Current = $I_a = I_{se} = I_L$
 Terminal Voltage = $V = E_g - I(R_a + R_{se})$
 Power developed in the Armature = $E_g I_a$
 Power delivered to the load = $V I_L$

Shunt generator:

In a shunt generator, the field winding is connected across the armature winding forming a parallel or shunt circuit. Therefore, full terminal voltage is applied across it. A very small field current I_{sh} , flows

through it because this winding has many turns of fine wire having very high resistance R_{sh} of the order of 100 ohms.

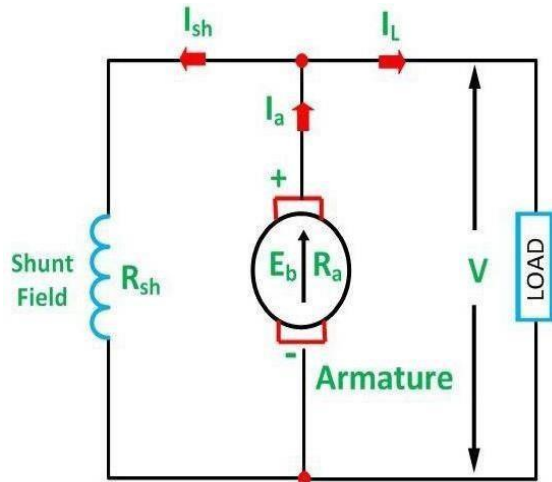

$$I_{sh} = \frac{V}{R_{sh}}$$
 Shunt field current

$$I_a = I_L + I_{sh}$$
 Armature Current

$$V = E_g - I_a R_a$$
 Terminal Voltage
 Power developed in the Armature = $E_g I_a$
 Power delivered to the load = $V I_L$

Compound generators:

The generator which has both shunt and series fields is called the compound wound generators. The compound-wound D.C generator has two sets of field windings. One set is made of low-resistance windings and is connected in series with the armature circuit. The other set is made of high-resistance wire and connected in parallel with the armature circuit.

When series field aids the shunt field, generator is said to be cumulatively compounded. On the other hand if series field opposes the shunt field, the generator is said to be differentially compounded.

A compound wound D.C generator can be either short-shunt or long-shunt. In a long shunt wound generator, the shunt field winding is parallel with both armature and series field winding. In a Short Shunt Compound Wound Generator, the shunt field winding is connected in parallel with the armature winding only.

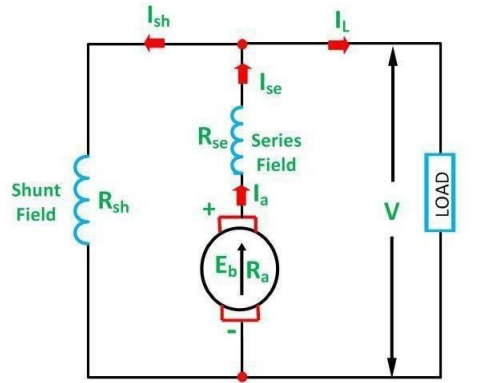
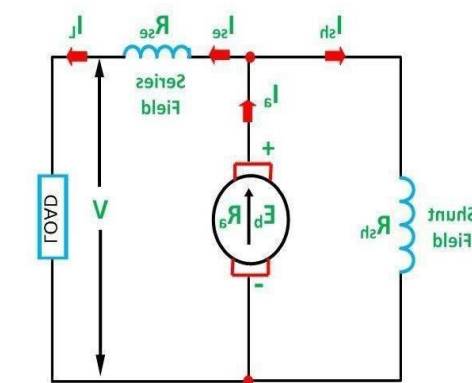

Circuit Globe

Circuit Globe

Short shunt

Series field current (I_{se}) = I_L

Shunt field current (I_{sh}) = $\frac{(V + I_{se}R_{se})}{R_{sh}}$

Armature Current (I_a) = $I_L + I_{sh}$

Terminal Voltage $V = E_g - I_a R_a - I_{se} R_{se}$

Power developed in the Armature = $E_g I_a$

Power delivered to the load = $V I_L$

long shunt

Series field current (I_{se}) = $I_a = I_L + I_{sh}$
 $V (I_{sh}) = \frac{V}{R_{sh}}$

Shunt field current

Terminal Voltage $V = E_g - I (R_a +$

$R_{se})$

Power developed in the Armature = $E_g I_a$

Power delivered to the load = $V I_L$

Losses In Dc Machine:

Losses in a DC machine may be divided in to three classes

- copper loss
- Core loss or iron loss
- Mechanical loss

Copper loss: These losses occur due to currents in the various windings of the machine.

- Armature copper loss = $I_a^2 R_a$. This is the loss due to current flowing in the armature windings of the machine.
- Shunt field copper loss = $I_{sh}^2 R_{sh}$. This loss is due to current flowing in the shunt field windings of the machine.
- Series field copper loss = $I_{se}^2 R_{se}$. This loss is due to current flowing in the series field windings of the machine.

Core loss or iron loss: Core loss or iron loss occurs in the armature core of a dc machine and is due to the rotation of armature core in the magnetic flux produced by the field system. Iron loss consists of a. Hysteresis loss b. Eddy current loss.

Hysteresis loss: This loss is due to the reversal of magnetization of armature core as the core passes under north and south poles alternatively. This loss depends on the volume and grade of iron, maximum value of flux density and frequency. Hysteresis loss is given by Steinmetz formula.

$$W_h = \eta B_m^{1.6} f V \text{ watts}$$

Where η = Steinmetz hysteresis co-efficient

B_m = Maximum flux density in Wb/m²

f = Frequency in Hz

V = Volume of the armature core in m³

Eddy Current Loss: Eddy currents are the currents set up by the induced emf in the armature core when the core cuts the magnetic flux. The loss occurring due to the flow of eddy current is known as eddy current loss. To reduce this loss the core is laminated, stacked and riveted. These laminations are insulated from each other by a thin coating of varnish. The effect of lamination is to reduce the current path because of increased resistance due to reduced cross section area of laminated core. Thus the magnitude of eddy current is reduced resulting in the reduction of eddy current loss.

Eddy Current loss is given by

$$W_e = K_e B_m^2 f^2 t^2 V \text{ watts}$$

Where K_e = Constant depending upon the electrical resistance of core

B_m = Maximum flux density in Wb/m²

f = Frequency in Hz

V = Volume of the armature core in m³

t = Thickness of the lamination in meters

Mechanical loss:

- a. Friction loss – brush friction loss and Bearing friction loss.
- b. Windage loss i.e ,air friction of rotating armature

Losses in DC machine may be sub divided into

- i. Constant losses
- ii. Variable losses

Constant losses: Those losses in a dc machine which remain constant at all loads are known as constant losses. The constant losses are iron losses, mechanical losses, shunt field losses

Variable losses: Those losses in a dc machine which vary with load are called variable losses. The variable losses are

- a. Armature copper loss ($I_a^2 R_a$)
- b. Series field copper loss ($I_{se}^2 R_{se}$)

Total losses = constant losses + Variable losses

Iron losses and mechanical losses together are called rotational losses.

Efficiency Of a Dc Generator: Efficiency is simply defined as the ratio of output power to the input power.

$$\eta = \frac{\text{Output}}{\text{input}} = \frac{\text{input}-\text{losses}}{\text{input}}$$

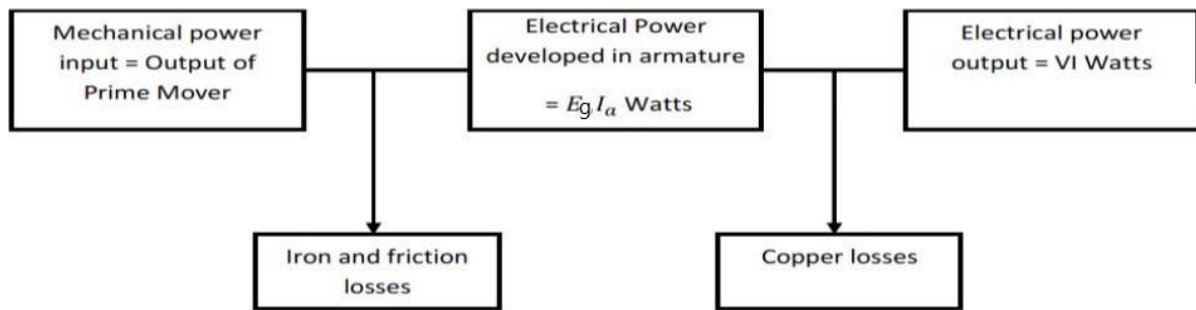

Fig: Power flow in a dc generator

Condition For Maximum Efficiency:

The efficiency of a dc generator is not constant but varies with load. Consider a shunt generator delivering a load current I_L at a terminal voltage V

Generator output = $V I_L$;

Generator input = output+ losses.

= $V I_L$ + Variable losses + Constant losses

= $V I_L + I_a^2 R_a + W_c$

= $V I_L + (I_a + I_{sh})^2 R_a + W_c$ [$I_a = I_L + I_{sh}$]

The shunt field current I_{sh} is small compared to I_L . Therefore I_{sh} can be neglected

Generator input = $V I_L + I_L^2 R_a + W_c$

$$\eta = \frac{\text{Output}}{\text{input}} = \frac{VI_L}{VI_L + I_L^2 R_a + W_c}$$

$$= \frac{1}{1 + \left(\frac{I_L R_a}{V} + \frac{W_c}{VI_L} \right)}$$

The efficiency will be maximum when the denominator is minimum i.e

$$\frac{d}{dI_L} \left(\frac{I_L R_a}{V} + \frac{W_c}{VI_L} \right) = 0$$

$$\frac{R_a}{V} - \frac{W_c}{VI_L^2} = 0$$

$$\frac{R_a}{V} = \frac{W_c}{VI_L^2}$$

$$I_L^2 R_a = W_c$$

i.e Variable loss = constant loss

The load current corresponding to maximum efficiency is given by

$$I_L = \sqrt{\frac{W_c}{R_a}}$$

Hence the efficiency of a dc generator will be maximum when the load current is such that variable loss is equal to the constant loss.

Armature Reaction:

In a DC machine, two kinds of magnetic fluxes are present; 'armature flux' and 'main field flux'. The effect of armature flux on the main field flux is called as armature reaction.

MNA And GNA:

EMF is induced in the armature conductors when they cut the magnetic field lines. There is an axis along which armature conductors move parallel to the flux lines and, hence, they do not cut the flux lines while on that plane. MNA (Magnetic Neutral Axis) may be defined as the axis along which no emf is generated in the armature conductors as they move parallel to the flux lines. Brushes are always placed along the MNA because reversal of current in the armature conductors takes place along this axis.

GNA (Geometrical Neutral Axis) may be defined as the axis which is perpendicular to the stator field axis.

- i. Consider, no current is flowing in the armature conductors and only the field winding is energized (as shown in fig: a). In this case, magnetic flux lines of the field poles are uniform and symmetrical to the polar axis. The 'Magnetic Neutral Axis' (M.N.A.) coincides with the 'Geometric Neutral Axis' (G.N.A.) and the main field mmf (F_f) acting alone.

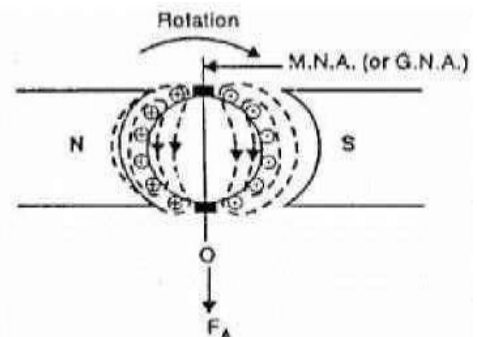
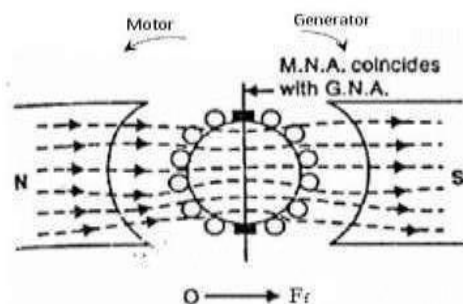

Fig: a

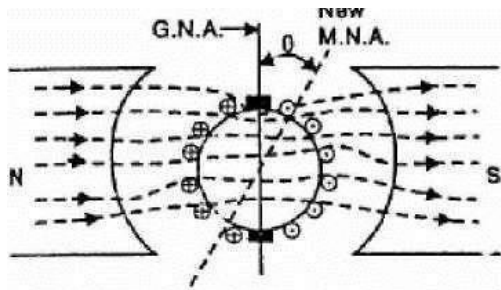

Fig: c

- ii. The axis of the main poles is called the direct axis (d-axis) and the interpolar axis is called quadrature axis (q-axis). Figure b shows armature flux lines due to the armature current. Field poles are de-energized. The armature mmf (F_a) is along the interpolar axis. F_a which is at 90° to the main field axis is known as cross magnetizing mmf.
- iii. Figure c shows the practical condition in which a DC machine operates when both the Field flux and armature flux are existing. Because of both fluxes are acting simultaneously, there is a shift in brush axis and crowding of flux lines at the trailing pole tip and flux lines are weakened or thinned at the leading pole tip. The armature flux superimposes with the main field flux and, hence, disturbs the main field flux. This effect is called as armature reaction in DC machines.

fig: b

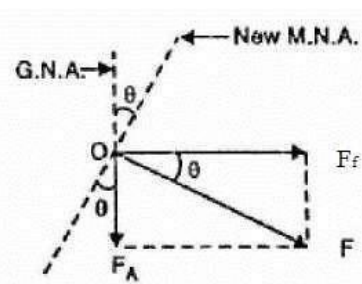

fig: d

If the iron in the magnetic circuit is assumed unsaturated, the net flux/pole remains unaffected by the armature reaction though the air gap flux density distribution gets distorted. If the main pole excitation is such that the iron is in the saturated region of magnetization (practical case) the increase in flux density at one end of the poles caused by armature reaction is less than the decrease at the other end, so that there is a net reduction in the flux/pole. This is called the demagnetizing effect.

The Adverse Effects of Armature Reaction:

1. Armature reaction weakens the main flux. In case of a dc generator, weakening of the main flux reduces the generated voltage.
2. Armature reaction distorts the main flux, hence the position of M.N.A. gets shifted (M.N.A. is perpendicular to the flux lines of main field flux). Brushes should be placed on the M.N.A., otherwise, it will lead to sparking at the surface of brushes. So, due to armature reaction, it is hard to determine the exact position of the MNA.

For a loaded dc generator, MNA will be shifted in the direction of the rotation. On the other hand, for a loaded dc motor, MNA will be shifted in the direction opposite to that of the rotation.

How To Reduce Armature Reaction?

For small machines (up to few kilowatts) no special efforts are taken to reduce the armature reaction. But for large DC machines, compensating winding and interpoles are used to get rid of the ill effects of armature reaction.

Compensating Winding: we know that the armature reaction is due to the presence of armature flux. Armature flux is produced due to the current flowing in armature conductors. Now, if we place another winding in close proximity of the armature winding and if it carries the same current but in the opposite direction as that of the armature current, then this will nullify the armature field. Such an additional winding is called as compensating winding and it is placed on the pole faces. Compensating winding is connected in series with the armature winding in such a way that it carries the current in opposite

direction. To minimize the cross magnetising effect compensating winding is used. This compensating winding produces an m.m.f which opposes the m.m.f produced by armature conductors.

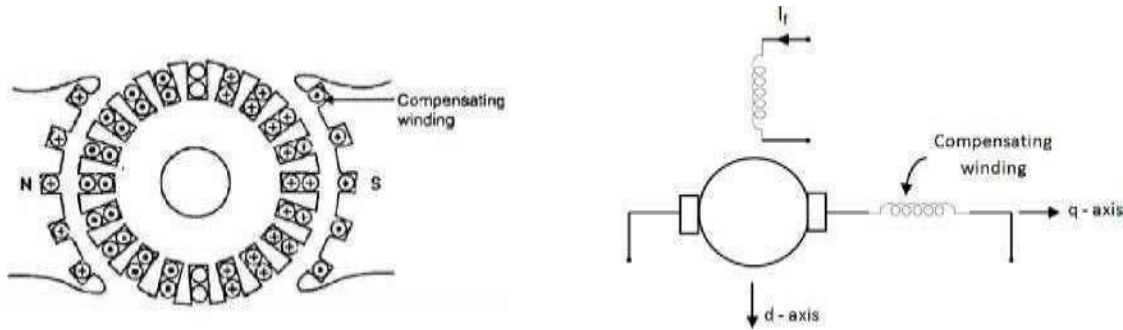
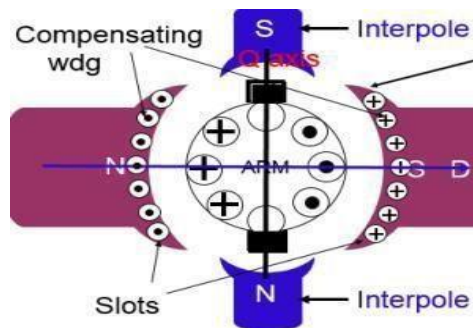

Fig: Compensating conductors in field poles and the connection of compensating conductors with armature

Interpoles: Interpoles are the small auxiliary poles placed between the main field poles. Like compensating winding, interpoles are also connected in series with armature winding such that the m.m.f produced by them opposes the m.m.f produced by armature conductor in interpolar region. In generators, the interpole polarity is same as that of main pole ahead such that they induce an e.m.f which is known as commutating or reversing e.m.f. This commutating e.m.f minimizes the reactance e.m.f and hence sparks or arcs are eliminated. Interpoles nullify the quadrature axis armature flux.



Commutation:

The process of reversal of current in the short circuited armature coil is called 'Commutation'. This process of reversal takes place when coil is passing through the interpolar axis (q-axis), the coil is short circuited through commutator segments. When commutation takes place, the coil undergoing commutation is short circuited by the brush.

The brief period during which the coil remains short circuited is known as commutation period T_c . If the current reversal i.e. The change from '+I' to zero and then to '-I' is completed by the end of short circuit or commutation period, then the commutation is 'ideal commutation'.

If current reversal is not complete by that time, then it will result in sparking in the brushes resulting in a 'non-ideal commutation.'

Let us discuss the process of commutation or current reversal in more detail with the help of the figures.

- Coil A is about to be short circuited because brush is about to come in contact with commutator segment 1. It is assumed that each coil carries 20A, so that brush current is 40A. Prior to the beginning of short-circuit, coil A carries 20A shown in fig :a
- In fig: b coil A has entered its period of short circuit and approximately at one-third of this period. As the area of contact of brush is more with segment 1 than with segment 2 (contact resistance varies inversely as the area of contact of brush) it receives 30A through segment 1 and 10 A through segment 2, the total again being 40A. The current through coil A has reduced down from 20A to 10A because the other 10A flows via segment 2.
- Fig: c shows the instant when the brush is one-half on segment 2 and one-half on segment 1. The brush again conducts 40 A; 20 A through segment 1 and 20 A through segment 2. The current through coil A has decreased to zero.
- Fig: d shows the instant when the brush is three-fourth on segment 2 and one-fourth on segment 1. The brush conducts a current of 40 A; 30 A through segment 2 and 10A through segment 1. The current in coil A is 10 A but in the reverse direction to that before the start of Commutation.

- Fig: e shows the instant when the brush is in contact only with segment 2. The brush again conducts 40 A; 20 A from coil A and 20 A from the adjacent coil to coil A. Now current in coil A is 20 A but in the reverse direction. Thus the coil A has undergone commutation.

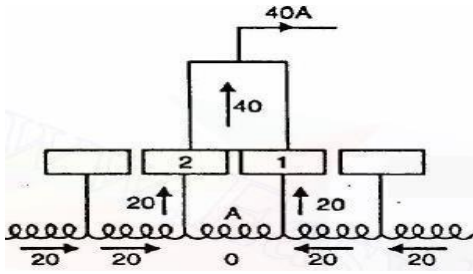

Fig: a

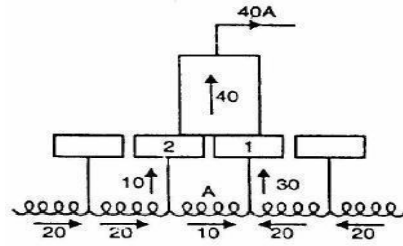

Fig: b

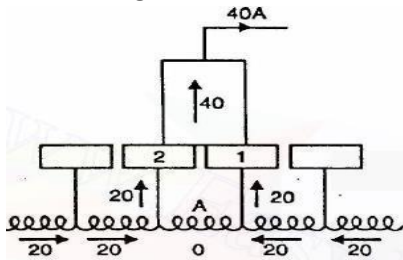

Fig: c

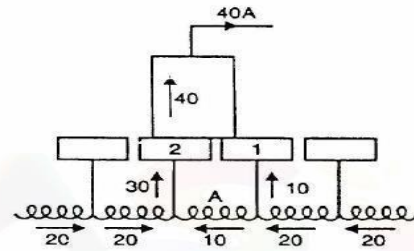

Fig: d

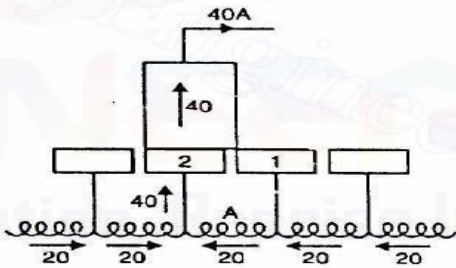
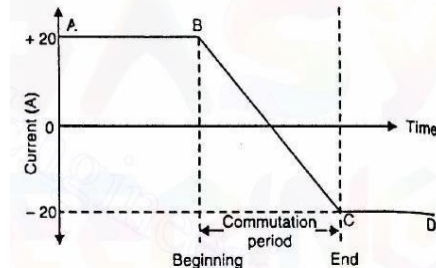

Fig: e



Reactance Voltage:

During commutation sparking occurs in the commutator segment and brush due to presence of reactance voltage. This voltage is generated due to change of current in the commutating coil for its self-inductance and also due to mutual inductance of the adjacent coils. This voltage is called reactance voltage and according to Lenz's law this induced voltage oppose its cause of production. Here the cause of production is the change in current in the coil under commutation. Thus the commutation becomes poorer.

Reactance voltage = co-efficient of self-inductance X rate of change of current = $L \frac{di}{dt}$

Time of short circuit = T_c = (time required by commutator to move a distance equal to the circumferential thickness of brush) – (one mica insulating strip) = Time of commutation

Let W_b = brush width in cm

W_i = width of mica insulation in cm

V_c = peripheral velocity of commutator segments in cm/sec.

Then
$$T_c = \frac{W_b - W_i}{V_c} \text{ sec}$$

Total change in current = $I - (-I) = 2I$

Therefore self-induced or reactance voltage = $L \frac{2I}{T_c}$ for linear commutation

Method of Improving Commutation

Improving commutation means to make current reversal in the short-circuited coil as sparkless as possible. Commutation can be improved in two ways by

Resistance Commutation:

If the contact resistance between the brush and the commutator is made large, then current would divide in the inverse ratio of contact resistances (as for any two resistances in parallel). This is the key point in improving commutation. This is achieved by using carbon brushes (instead of Cu brushes) which have high contact resistance. This method of improving commutation is called resistance commutation.

So high contact resistance of carbon brush improves commutation. **E.M.F**

commutation:

To neutralize sparking caused by reactance voltage in this method an emf is produced which acts in opposite direction to that of reactance voltage, so that the reactance voltage is completely eliminated. The neutralization of emf may be done in two ways (i) by giving brush a forward lead sufficient enough to bring the short circuited coil under the influence of next pole of opposite polarity or (ii) by using interpoles or composites. The second method is commonly employed.

Interpoles or Composites:

These are small poles fixed to the yoke and placed in between the main poles. They are wound with few turns of heavy gauge copper wire and are connected in series with the armature so that they carry full armature current. Their polarity in case of generator is that of the main pole ahead in the direction of rotation. Their polarity in case of motor is that of the main pole behind in the direction of rotation.

The functions of interpoles are

- i. to induce an emf which is equal and opposite to that of the reactance voltage.
- ii. Interpoles neutralize the cross magnetizing effect of armature reaction.

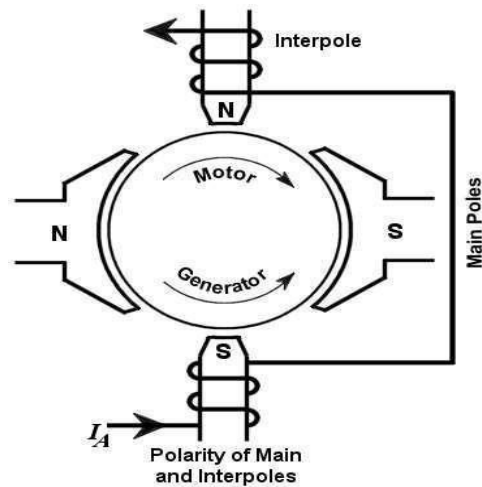

Characteristics of DC Generators:

Generally, following three characteristics of DC generators are taken into considerations:

- i. Open Circuit Characteristic (O.C.C.)
- ii. Internal or Total Characteristic
- iii. External Characteristic.

Characteristics of Separately Excited DC Generator:

i. Open Circuit Characteristic (O.C.C.) (E_0/I_f)

Open circuit characteristic is also known as magnetic characteristic or no-load saturation characteristic. This characteristic shows the relation between generated emf at no load (E_0) and the field current (I_f) at a given fixed speed. The O.C.C. curve is just the magnetization curve and it is practically similar for all type of generators. The data for O.C.C. curve is obtained by operating the generator at no load and keeping a constant speed. Field current is gradually increased and the corresponding terminal voltage is recorded. The connection arrangement to obtain O.C.C. curve is as shown in the figure below. For shunt or series excited generators, the field winding is disconnected from the machine and connected across an external supply.

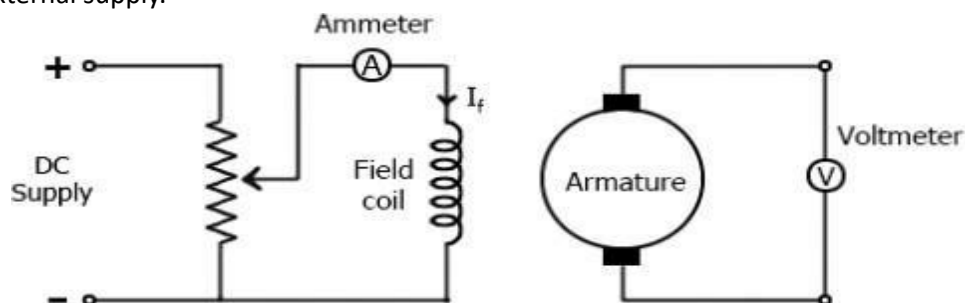

Now, from the emf equation of dc generator, we know that $E_g = k\phi$. Hence, the generated emf should be directly proportional to field flux (and hence, also directly proportional to the field current). However, even when the field current is zero, some amount of emf is generated (represented by OA in the figure below). This initially induced emf is due to the fact that there exists some residual magnetism in the field poles. Due to the residual magnetism, a small initial emf is induced in the armature. This initially induced emf aids the existing residual flux, and hence, increasing the overall field flux. This consequently

increases the induced emf. Thus, O.C.C. follows a straight line. However, as the flux density increases, the poles get saturated and the ϕ becomes practically constant. Thus, even we increase the I_f further, ϕ remains constant and hence, E_g also remains constant. Hence, the O.C.C. curve looks like the B-H characteristic.

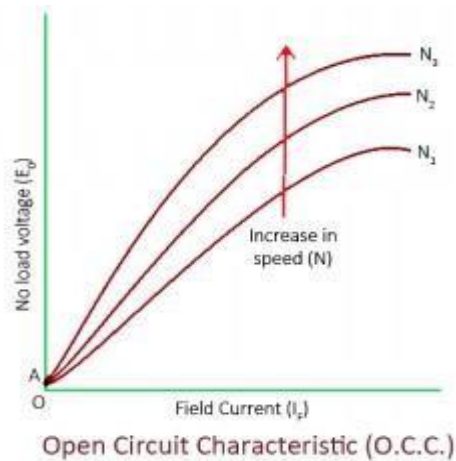

ii. Internal or Total Characteristic (E/I_a)

An internal characteristic curve shows the relation between the on-load generated emf (E_g) and the armature current (I_a). The on-load generated emf E_g is always less than E_0 due to the armature reaction. E_g can be determined by subtracting the drop due to demagnetizing effect of armature reaction from no-load voltage E_0 . Therefore, internal characteristic curve lies below the O.C.C. curve.

iii. External Characteristic (V/I_L)

An external characteristic curve shows the relation between terminal voltage (V) and the load current (I_L). Terminal voltage V is less than the generated emf E_g due to voltage drop in the armature circuit. Therefore, external characteristic curve lies below the internal characteristic curve. External characteristics are very important to determine the suitability of a generator for a given purpose. Therefore, this type of characteristic is sometimes also called as performance characteristic or load characteristic. Internal and external characteristic curves are shown below for each type of generator.

Characteristics of Separately Excited DC Generator:

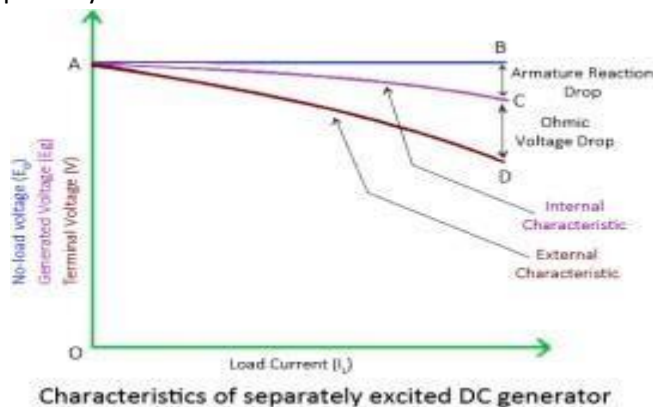

If there is no armature reaction and armature voltage drop, the voltage will remain constant for any load current. Thus, the straight line AB in above figure represents the no-load voltage vs. load current I_L . Due to the demagnetizing effect of armature reaction, the on-load generated emf is less than the no-load voltage. The curve AC represents the on-load generated emf E_g vs. load current I_L , i.e. Internal

characteristic (as $I_a = I_L$ for a separately excited dc generator). Also, the terminal voltage is lesser due to ohmic drop occurring in the armature and brushes. The curve AD represents the terminal voltage vs. load current i.e. external characteristic.

Characteristics of DC Shunt Generator:

To determine the internal and external load characteristics of a DC shunt generator the machine is allowed to build up its voltage before applying any external load. To build up voltage of a shunt generator, the generator is driven at the rated speed by a prime mover. Initial voltage is induced due to residual magnetism in the field poles. When the generator has built up the voltage, it is gradually loaded with resistive load and readings are taken at suitable intervals.

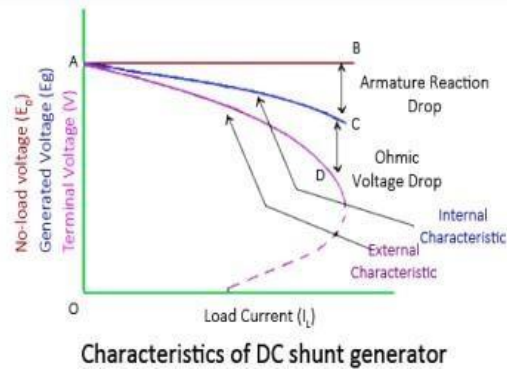
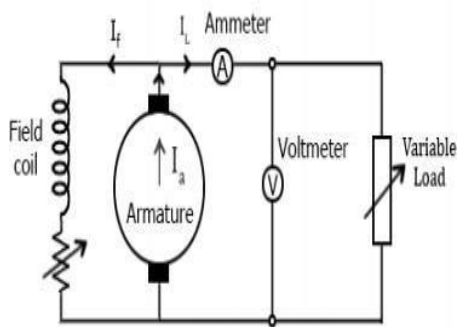

During a normal running condition, when load resistance is decreased, the load current increases. But, as we go on decreasing the load resistance, terminal voltage also falls. So, load resistance can be decreased up to a certain limit, after which the terminal voltage drastically decreases due to excessive armature reaction at very high armature current and increased $I^2 R$ losses. Hence, beyond this limit any further decrease in load resistance results in decreasing load current. Consequently, the external characteristic curve turns back.

Characteristics of DC Series Generator

The curve AB in above figure identical to open circuit characteristic (O.C.C.) curve. This is because in DC series generators field winding is connected in series with armature and load. Hence, here load current is similar to field current (i.e. $I_L = I_f$). The curve OC and OD represent internal and external characteristic respectively. In a DC series generator, terminal voltage increases with the load current.

This is because, as the load current increases, field current also increases. However, terminal voltage starts decreasing with increase in load current due to excessive armature reaction.

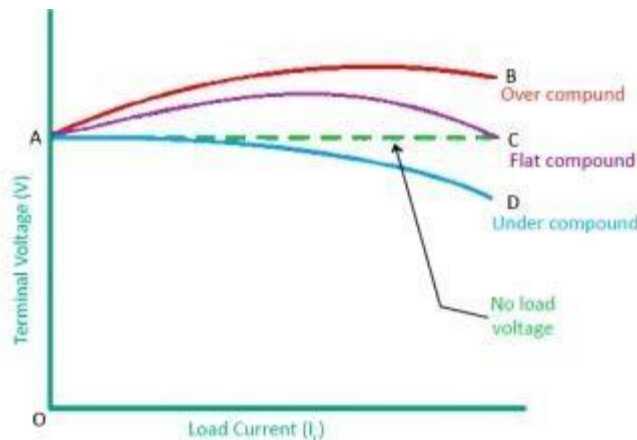

External characteristic of DC compound generator

because, as the load current increases, field current also increases. However, terminal voltage starts decreasing with increase in load current due to demagnetizing effects of the reaction.

Characteristics Of DC Compound Generator:

The above figure shows the external characteristics of DC compound generators. If series winding amp-turns are adjusted so that, increase in load current cause increase in terminal voltage then the generator is called to be over compounded. The external characteristic for over compounded generator is shown by the curve AB in above figure. If series winding amp-turns are adjusted so that, the terminal voltage remains constant even the load current is increased, then the generator is called to be flat compounded. The external characteristic for a flat compounded generator is show by the curve AC. If the series winding has lesser number of turns than that would be required to be flat compounded, then the generator is called to be under compounded. The external characteristics for an under compounded generator are shown by the curve AD.

Build-up of E.M.F of a Shunt Generator:

When the armature is rotating with armature open circuited, an emf is induced in the armature because of the residual flux. When the field winding is connected with the armature, a current flows through the field winding (in case of shunt field winding, field current flows even on No-load and in case of series field winding only with load) and produces additional flux. This additional flux along with the residual flux generates higher voltage. This higher voltage circulates more current to generate further higher voltage. This is a cumulative process till the saturation is attained.

Here OM is the field resistance curve. Initially there will be residual voltage which will create OA field current. This field current will increase the existing magnetic field and the induced voltage will increase up-to OB. This OB voltage will further applied to the field winding and increase the field current to OC. This process will continue upto the point L where the emf curve intersect with field resistance and finally the induced voltage will be OJ. This way voltage builds-up in dc generator.

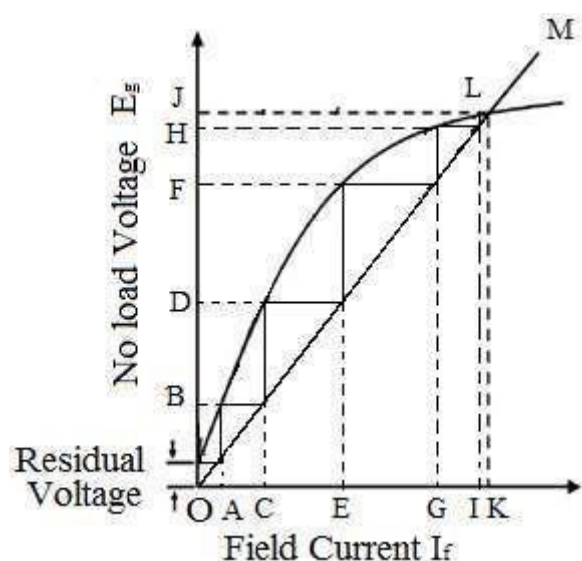

The necessary conditions for voltage build-up in a shunt generator are:

1. There must be some residual magnetism in generator poles.
2. The connections of the field winding should be such that the field current strengthens the residual magnetism.
3. The resistance of the field circuit should be less than the critical resistance. In other words, the speed of the generator should be higher than the critical speed. **Critical Resistance:-**

The voltage to which it builds is decided by the resistance of the field winding as shown in the figure below. If field circuit resistance is increased such that the resistance line does not cut OCC like 'OP' in the figure, then the machine will fail to build up voltage to the rated value. The slope of the air gap line drawn as a tangent (OQ) to the initial linear portion of the curve represents the maximum resistance that the field circuit can have beyond which the machine fails to build up voltage. This value of field circuit resistance is called critical field resistance. The field circuit is generally designed to have a resistance value less than this so that the machine builds up the voltage to the rated value.

Critical field resistance is defined as the maximum field circuit resistance for a given speed with which the shunt generator would excite. The shunt generator will build up voltage only if field circuit resistance is less than *critical field resistance*.

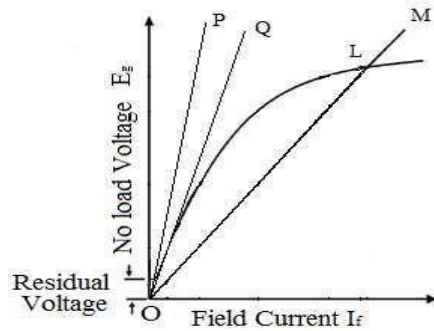

Critical Speed:

Voltage of a dc generator is proportional to its speed. Thus when speed will be reduced then the induced voltage will reduced. There can be such situation occur when the speed will be so low that the existing field winding resistance voltage build up will not occur. The speed of the generator can be lowered up to a certain level.

This minimum value of the speed of the generator for which the generator can excite is called *critical speed*. It can also define as that speed of a generator for which the existing field resistance of generator becomes its critical field resistance.

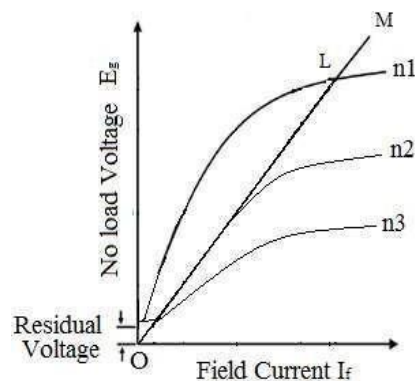

In the above figure it is showing that when speed of the generator changes from n_1 to n_2 and then n_3 emf production changes accordingly. Here $n_1 > n_2 > n_3$. For speed n_3 voltage build-up is not possible. The speed n_2 is the critical speed. At speed n_2 generator field resistance become its critical field resistance.

Parallel Operation of DC Generator:

Conditions for Parallel Operation of DC Generator:

1. The terminal voltage must be the same.
2. The polarities of the generator must be identical.
3. The prime movers driving the armature of the generators must have similar and stable rotational characteristics.
4. The change of voltage with the change of load must be the same character.

Advantages of DC generator operating in parallel:

In a dc power plant, power is usually supplied from several generators of small ratings connected in parallel instead of from one large generator. This is due to the following reasons:

a. Continuity of service:

If a single large generator is used in the power plant, then in case of its breakdown, the whole plant will be shut down. However, if power is supplied from a number of small units operating in parallel, then in case of failure of one unit, the continuity of supply can be maintained by other healthy units.

b. Efficiency:

Generators run most efficiently when loaded to their rated capacity. Therefore, when load demand on power plant decreases, one or more generators can be shut down and the remaining units can be efficiently loaded.

c. Maintenance and repair:

Generators generally require routine-maintenance and repair. Therefore, if generators are operated in parallel, the routine or emergency operations can be performed by isolating the affected generator while load is being supplied by other units. This leads to both safety and economy.

d. Increasing plant capacity:

In the modern world of increasing population, the use of electricity is continuously increasing. When added capacity is required, the new unit can be simply paralleled with the old units.

e. Non-availability of single large unit:

In many situations, a single unit of desired large capacity may not be available. In that case a number of smaller units can be operated in parallel to meet the load requirement. Generally a single large unit is more expensive.

Application of DC generators:

Application of separately excited dc generator:

- Used as Electroplating and as booster.
- Used with field regulators
- Used as power suppliers on big turbo alternator
- Used as exciters

Application of Shunt Generator:

- Used with field regulators
- Used for battery charging

Application of Series Generator:

- Used for lightening
- Used as constant current generators
- Used as booster

Application of Compound Generator

- Used as compensator
- Used for ordinary lightning and power purposes

DC MOTOR

Working Principle Of a Dc Motor:

The DC motor is the device which converts electrical energy into the mechanical energy. It works on the principle that “the current carrying conductor placed in a magnetic field, the conductor experienced a mechanical force” whose direction is given by Fleming’s left-hand rule.

Fleming Left Hand Rule:

Statement: Keep the thumb, middle finger and the index finger of the left hand are displaced at right angles to each other ,point the index finger in the direction of the magnetic field and the middle finger in the direction of the current, then the thumb will point in the direction of force acting on the conductor.

Back Emf:

When the armature of DC motor rotates under the influence of the driving torque ,the armature conductors move through the magnetic field and hence emf is induced in them. The induced emf acts in opposite direction to the applied voltage V and is known as back emf or Counter emf E_b . The back emf (also called counter emf) is given by

$$E_b = \frac{P\Phi ZN}{60A}$$

where, P=number of poles of dc motor Φ =
flux per pole

Z=total number of armature conductors

N=armature speed

A=number of parallel paths in armature winding

As all other parameters are constant, therefore, $E_b \propto N$

Significance of back emf in dc motor

- Back emf makes dc motor a self-regulating motor i.e it makes the motor to draw as much armature current (I_a) as is just sufficient to develop the torque required by the load.

$$I_a = \frac{V - E_b}{R_a}$$

V and R_a are fixed, therefore, armature current I_a depends on back emf, which in turn depends on speed of the motor.

- As the back emf opposes supply voltage V, therefore, supply voltage has to force current through the armature against the back emf, to keep armature rotating. The electric work done in overcoming and causing the current to flow against the back emf is converted into mechanical energy developed in the armature. It follows, therefore, that energy conversion in a dc motor is only possible due to the production of back emf. Mechanical power developed in the armature = $E_b I_a$

Power Equation of a D.C. Motor

The voltage equation of a d.c. motor is given by,

$$V = E_b + I_a R_a$$

Multiplying both sides of the above equation by I_a we get,

$$VI_a = E_b I_a + I_a^2 R_a$$

This equation is called power equation of a d.c. motor.

VI_a = Net electrical power input to the armature measured in watts.

$I_a^2 R_a$ = Power loss due the resistance of the armature called armature copper loss.

So difference between VI_a and $I_a^2 R_a$ i.e. input - losses gives the output of the armature.

So $E_b I_a$ is called electrical equivalent of gross mechanical power developed by the armature.

This is denoted as P_m

Power input to the armature - Armature copper loss = Gross mechanical power developed in the armature.

Condition for Maximum Power:

For a motor from power equation it is known that, P_m

= Gross mechanical power developed = $E_b I_a$

$$= VI_a - I_a^2 R_a$$

Since V and R_a are fixed, power developed by the motor depends upon armature current.

For maximum power (P_m), $\frac{dP_m}{dI_a} = 0$

$$V - 2I_a R_a = 0$$

$$I_a = \frac{V}{2R_a}$$

$$I_a R_a = \frac{V}{2}$$

Substituting in voltage equation,

$$V = E_b + I_a R_a = E_b + \frac{V}{2}$$

$$E_b = \frac{V}{2} \dots\dots\dots \text{Condition for maximum power}$$

Torque Equation of a Dc Motor

Torque is the turning moment of a force about an axis and is measured by the product of force (F) and radius (r) at right angle to which the force acts, i.e $T = F \times r$

The sum of the torques due to all the armature conductors is known as gross or armature torque (T_a)

Force on each conductor, $F = B \times i \times l$ newtons

Torque due to one conductor = $F \times r$

Total armature torque, $T_a = Z \times F \times r$ newton-meter

$$T_a = Z \times B \times i \times l \times r$$

$$T_a = Z \times \left(\frac{\Phi}{a}\right) \times \left(\frac{I_a}{A}\right) \times l \times r \quad \left[\text{since } i = \frac{I_a}{A}, B = \frac{\Phi}{a}, a = \frac{2\pi r l}{P}\right]$$

$$= Z \times \left(\frac{\Phi}{\frac{2\pi r l}{P}}\right) \times \left(\frac{I_a}{A}\right) \times l \times r$$

$$= Z \times \left(\frac{\Phi I_a P}{2\pi A}\right)$$

$$T_a = 0.159 Z \Phi I_a (P/A) \text{ N-m}$$

$$T_a = 9.55 \times \left(\frac{E_b I_a}{N}\right) \text{ N-m}$$

Since Z, P and A are fixed for a given machine,

$$T_a \propto \Phi I_a$$

Hence torque in a d.c motor is directly proportional to flux per pole and armature current.

For a **shunt motor**, flux Φ is constant

$$T_a \propto I_a$$

For a **series motor**, flux Φ is directly proportional to armature current I_a provided magnetic saturation does not take place.

$$T_a \propto I_a^2$$

Shaft Torque:

The actual torque available at the shaft for doing useful mechanical work is known as Shaft Torque. It is so called because it is available on the shaft of the motor. It is represented by the symbol T_{sh} . A part of it is lost to overcome the iron and mechanical (friction and windage) losses. Therefore, shaft torque (T_{sh}) is somewhat less than the torque developed in the armature (T_a). The difference the armature torque and the shaft torque ($T_a - T_{sh}$) is called lost torque.

$$T_a - T_{sh} = 9.55 \times \left(\frac{\text{Iron and frictional losses}}{N}\right)$$

$$\text{Output} = T_{sh} \times 2\pi N$$

$$T_{sh} = \left(\frac{\text{Output in watts}}{2\pi N}\right) \text{ N-m}$$

$$T_{sh} = \left(\frac{\text{Output in watts}}{2\pi N/60}\right) \text{ N-m} \quad (\text{N in r.p.s})$$

$$T_{sh} = \left(\frac{\text{Output in watts}}{2\pi N/60}\right) \text{ N-m} \quad (\text{N in r.p.m})$$

$$T_{sh} = 9.55 \times \left(\frac{\text{Output in watts}}{N}\right) \text{ N-m}$$

Brake Horse Power (B.H.P.):

The horse power developed by the shaft torque is known as brake horse power (b.h.p). If T_{sh} is the shaft torque in Newton Meters and N is the speed in r.p.m then,

$$\text{Output in B.H.P} = \left(\frac{2\pi NT_{sh}}{60 \times 746} \right)$$

Characteristics of Dc Motors:

Generally, three characteristic curves are considered important for DC motors which are,

- i. Torque vs. armature current,
- ii. Speed vs. armature current and iii. Speed vs. torque.

Characteristics of DC

Series Motors:

a. Torque Vs. Armature Current (T_a - I_a)

This characteristic is also known as electrical characteristic. We know that torque is directly proportional to the product of armature current and field flux, $T_a \propto \phi \cdot I_a$. In DC series motors, field winding is connected in series with the armature, i.e. $I_a = I_f$. Therefore, before magnetic saturation of the field, flux ϕ is directly proportional to I_a . Hence, before magnetic saturation $T_a \propto I_a^2$. Therefore, the T_a - I_a curve is parabola for smaller values of I_a .

After magnetic saturation of the field poles, flux ϕ is independent of armature current I_a . Therefore, the torque varies proportionally to I_a only, $T_a \propto I_a$. Therefore, after magnetic saturation, T_a - I_a curve becomes a straight line.

The shaft torque (T_{sh}) is less than armature torque (T_a) due to stray losses. Hence, the curve T_{sh} Vs I_a lies slightly lower. In DC series motors, (prior to magnetic saturation) torque increases as the square of armature current, these motors are used where high starting torque is required.

b. Speed Vs. Armature Current (N - I_a):

We know the relation, $N \propto E_b / \phi$

For small load current (and hence for small armature current) change in back emf E_b is small and it may be neglected. Hence, for small currents speed is inversely proportional to ϕ . As we know, flux is directly proportional to I_a , speed is inversely proportional to I_a . Therefore, when armature current is very small the speed becomes dangerously high. That is why a series motor should never be started without some mechanical load.

But, at heavy loads, armature current I_a is large. And hence, speed is low which results in decreased back emf E_b . Due to decreased E_b , more armature current is allowed.

c. Speed Vs. Torque (N - T_a):

This characteristic is also called as mechanical characteristic. From the above two characteristics of DC series motor, it can be found that when speed is high, torque is low and vice versa.

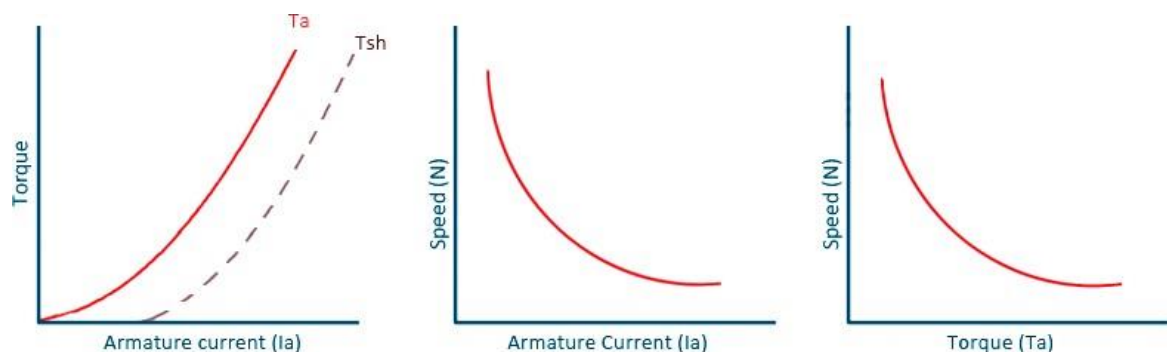

Characteristics of DC series motor

Shunt Motors:

Characteristics of DC

a. Torque Vs. Armature Current (Ta-Ia):

In case of DC shunt motors, we can assume the field flux ϕ to be constant. Though at heavy loads, ϕ decreases in a small amount due to increased armature reaction. As we are neglecting the change in the flux ϕ , we can say that torque is proportional to armature current. Hence, the Ta-Ia characteristic for a dc shunt motor will be a straight line through the origin. Since heavy starting load needs heavy starting current, shunt motor should never be started on a heavy load.

b. Speed Vs. Armature Current (N-Ia)

As flux ϕ is assumed to be constant, we can say $N \propto E_b$. But, as back emf is also almost constant, the speed should remain constant. But practically, ϕ as well as E_b decreases with increase in load. Back emf E_b decreases slightly more than ϕ , therefore, the speed decreases slightly. Generally, the speed decreases only by 5 to 15% of full load speed. Therefore, a shunt motor can be assumed as a constant speed motor. In speed vs. armature current characteristic in the following figure, the straight horizontal line represents the ideal characteristic and the actual characteristic is shown by the dotted line.

c. Speed Vs. Torque (N-Ta):

$$N \propto \frac{E_b}{\phi}$$

$$N = \frac{V - I_a R_a}{k\phi}$$

$$T_a \propto \phi I_a$$

$$I_a = \frac{T_a}{k\phi}$$

$$N = \frac{V}{k\phi} - \frac{R_a}{k\phi^2} T_a$$

Thus with increase with torque the speed of DC shunt motor decreases. The nature of the characteristics is drooping in nature.

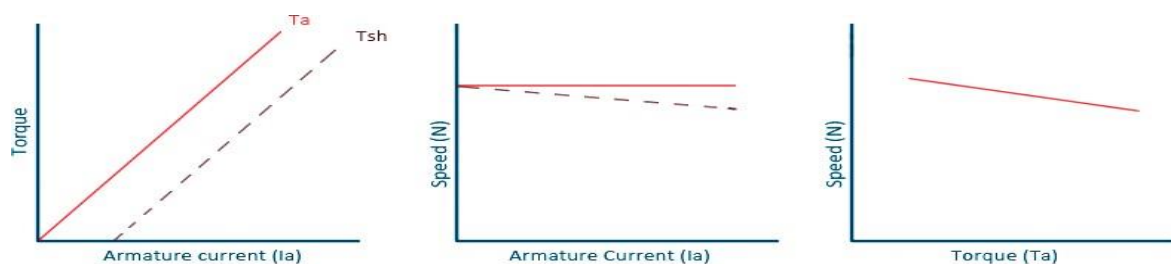

Characteristics of DC shunt motor

Characteristics of DC

Compound Motor:

DC compound motors have both series as well as shunt winding. In a compound motor, if series and shunt windings are connected such that series flux is in direction as that of the shunt flux then the motor is said to be cumulatively compounded. And if the series flux is opposite to the direction of the shunt flux, then the motor is said to be differentially compounded. Characteristics of both these compound motors are explained below.

a. Cumulative compound motor:

Cumulative compound motors are used where series characteristics are required but the load is likely to be removed completely. Series winding takes care of the heavy load, whereas the shunt winding prevents the motor from running at dangerously high speed when the load is suddenly removed. These motors have generally employed a flywheel, where sudden and temporary loads are applied like in rolling mills.

b. Differential compound motor:

Since in differential field motors, series flux opposes shunt flux, the total flux decreases with increase in load. Due to this, the speed remains almost constant or even it may increase slightly with increase in load ($N \propto E_b/\phi$). Differential compound motors are not commonly used, but they find limited applications in experimental and research work.

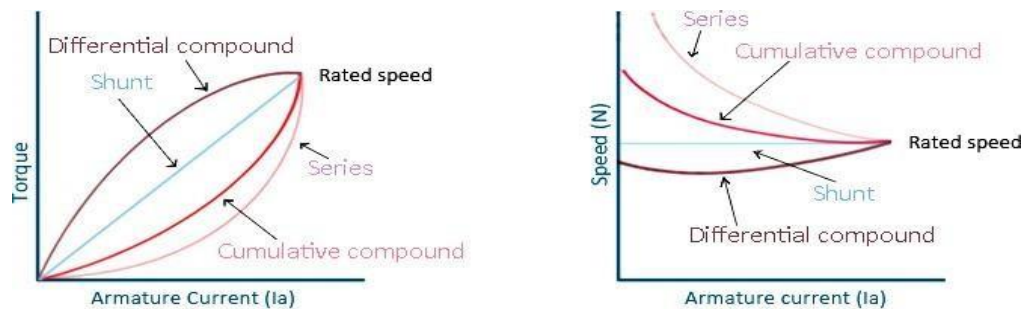

Characteristics of DC compound motor

STARTING OF DC MOTORS

A **starter** is a device to start and accelerate a motor. A controller is a device to start the motor, control and reverse the speed of the DC motor and stop the motor. While starting the DC motor, it draws the heavy current which damages the motor. The starter reduces the heavy current and protects the system from damage.

Need of Starters for DC Motors

The dc motor has no back EMF. At the starting of the motor, the armature current is controlled by the resistance of the circuit. The resistance of the armature is low, and when the full voltage is applied at the standstill condition of the motor, the armature current becomes very high which damage the parts of the motor.

Characteristics of DC

Because of the high armature current, the additional resistance is placed in the armature circuit at starting. The starting resistance of the machine is cut out of the circuit when the machine gains its speeds. The armature current of a motor is given by

$$I_a = \frac{V - E}{R_a} \dots \dots \dots (1)$$

Thus, I_a depends upon E and R_a , if V is kept constant. When the motor is first switched ON, the armature is stationary. Hence, the back EMF E_b is also zero. The initial starting armature current I_{as} is given by the equation shown below.

$$I_{as} = \frac{V - 0}{R_a} = \frac{V}{R_a} \dots \dots \dots (2)$$

Since, the armature resistance of a motor is very small, generally less than one ohm. Therefore, the starting armature current I_{as} would be very large.

As the motor speed increases, the back EMF increases and the difference $(V - E)$ go on decreasing. This results in a gradual decrease of armature current until the motor attains its stable speed and the corresponding back EMF. Under this condition, the armature current reaches its desired value. Thus, it is found that the back EMF helps the armature resistance in limiting the current through the armature.

3 POINT STARTER

3 Point Starter is a device whose main function is starting and maintaining the speed of the DC shunt motor. The 3 point starter connects the resistance in series with the circuit which reduces the high starting current and hence protects the machines from damage. Mainly there are three main points or terminals in 3 point starter of DC motor. They are as follows

- **L** is known as Line terminal, which is connected to the positive supply.□
- **A** is known as the armature terminal and is connected to the armature windings.□
- **F** or **Z** is known as the field terminal and is connected to the field terminal windings.□

The **3 Point DC Shunt Motor** Starter is shown in the figure below

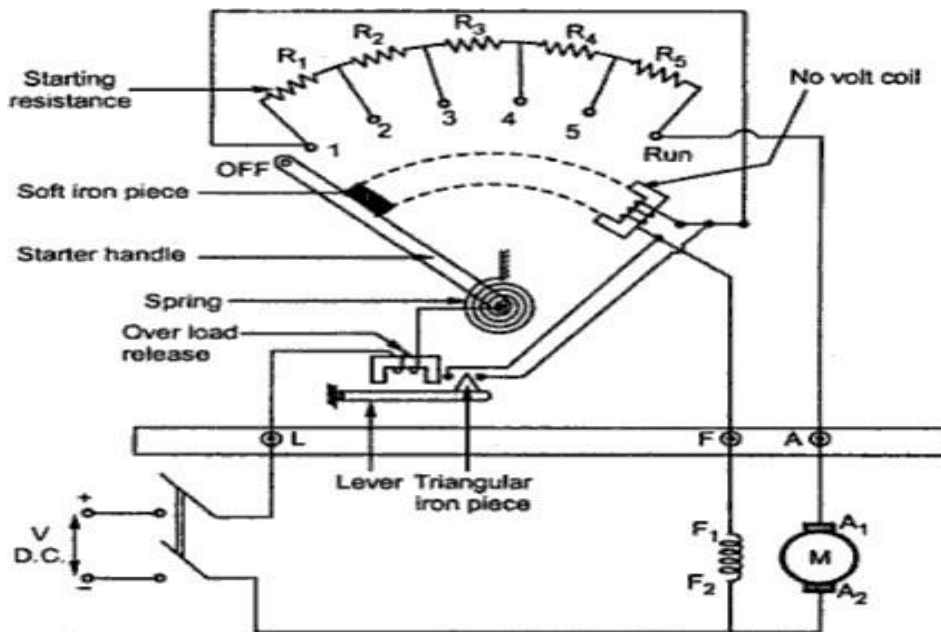

3 point Starter

It consists of a graded resistance R to limit the starting current. The handle H is kept in the **OFF** position by a spring S . The handle H is manually moved, for starting the motor and when it makes contact with resistance stud one the motor is said to be in the **START** position. In this initial start position, the field winding of the motor receives the full supply voltage, and the armature current is limited to a certain safe value by the resistance ($R = R_1 + R_2 + R_3 + R_4$).

Working of 3 Point Starter

The starter handle is now moved from stud to stud, and this builds up the speed of the motor until it reaches the **RUN** position. The Studs are the contact point of the resistance. In the **RUN** position, three main points are considered. They are as follows.

- The motor attains the full speed.□
- The supply is direct across both the windings of the motor.□
- The resistance R is completely cut out.□

The handle H is held in **RUN** position by an electromagnet energised by a **no volt trip coil (NVC)**. This no volt trip coil is connected in series with the field winding of the motor. In the event of switching **OFF**, or when the supply voltage falls below a predetermined value, or the complete failure of supply while the motor is running, **NVC** is energised. The handle is released and pulled back to the **OFF** position by the action of the spring. The current to the motor is cut off, and the motor is not restarted without a resistance R in the armature circuit. The no voltage coil also provides protection against an open circuit in the field windings.

The No Voltage Coil (**NVC**) is called **NO-VOLT** or **UNDERVOLTAGE** protection of the motor. Without this protection, the supply voltage might be restored with the handle in the **RUN** position. The full line voltage is directly applied to the armature. As a result, a large amount of current is generated.

The other protective device incorporated in the starter is the overload protection. The **Over Load Trip Coil (OLC)** and the **No Voltage Coil (NVC)** provide the overload protection of the motor. The overload coil is made up of a small electromagnet, which carries the armature current. The magnetic pull of the Overload trip coil is insufficient to attract the strip P, for the normal values of the armature current.

When the motor is overloaded, that is the armature current exceeds the normal rated value, P is attracted by the electromagnet of the OLC and closes the contact aa thus, the No Voltage Coil is short-circuited, shown in the figure of 3 Point Starter. As a result, the handle H is released, which returns to the OFF position, and the motor supply is cut off.

To stop the motor, the starter handle should never be pulled back as this would result in burning the starter contacts. Thus, to stop the motor, the main switch of the motor should be opened.

Drawbacks of a 3 Point Starter

The following drawbacks of a 3 point starter are as follows:-

- The 3 point starter suffers from a serious drawback for motors with a large variation of speed by adjustment of the field rheostat.□
- To increase the speed of the motor, the field resistance should be increased. Therefore, the current through the shunt field is reduced.□
- The field current may become very low because of the addition of high resistance to obtain a high speed.□
- A very low field current will make the holding electromagnet too weak to overcome the force exerted by the spring.□
- The holding magnet may release the arm of the starter during the normal operation of the motor and thus, disconnect the motor from the line. This is not a desirable action.□

Hence, to overcome this difficulty, the 4 Point Starter is used.

4 POINT STARTER

A 4 Point Starter is almost similar in functional characteristics like 3 Point Starter. In the absence of back EMF, the 4 Point Starter acts as a current limiting device while starting of the DC motor. 4 Point Starter also acts a protecting device.

The basic difference in 4 Point Starter as compared to 3 Point Starter is that in this a holding coil is removed from the shunt field circuit. This coil after removing is connected across the line in series with a current limiting resistance R. The studs are the contact points of the resistance represented by 1, 2, 3, 4, 5 in the figure below. The schematic connection diagram of a 4 Point Starter is shown below.

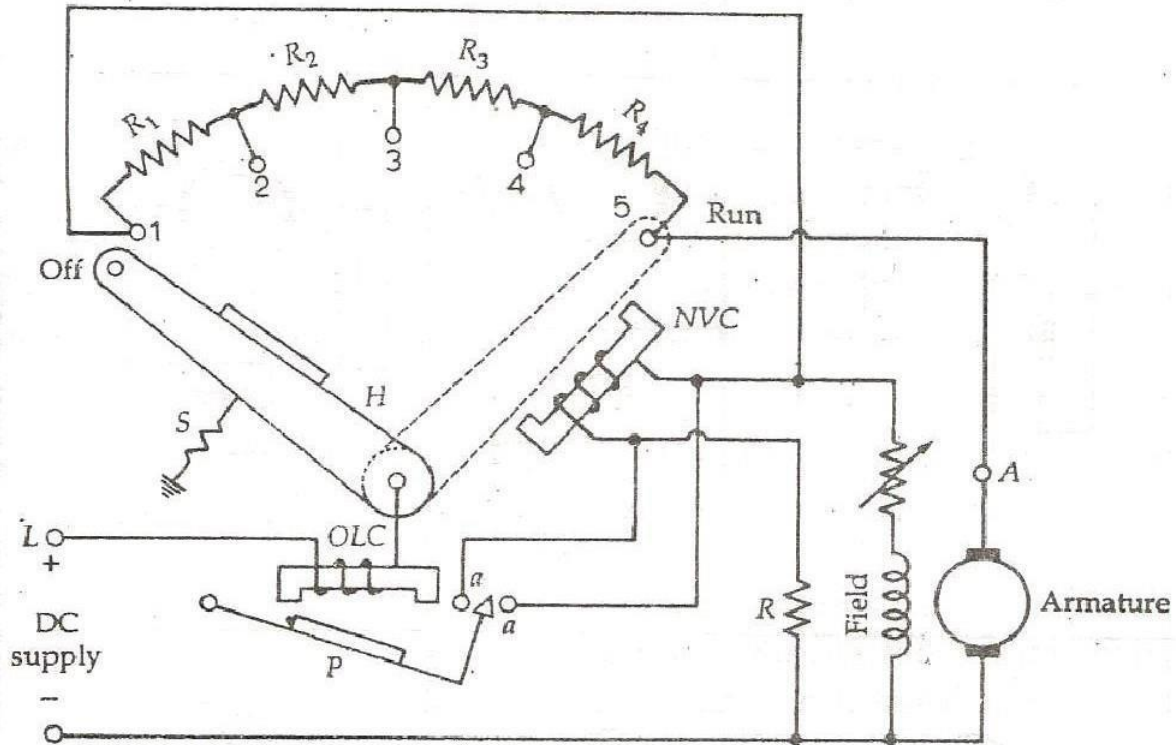

The above arrangement forms three parallel circuits. They are as follows:-

- Armature, starting the resistance and the shunt field winding.□
- A variable resistance and the shunt field winding.□
- Holding coil and the current limiting resistance.□

With the above three arrangements of the circuit, there will be no effect on the current through the holding coil if there is any variation in speed of the motor or any change in field current of the motor. This is because the two circuits are independent of each other.

The only limitation or the drawback of the 4 point starter is that it cannot limit or control the high current speed of the motor. If the field winding of the motor gets opened under the running condition, the field current automatically reduces to zero. But as some of the residual flux is still present in the motor, and we know that the flux is directly proportional to the speed of the motor. Therefore, the speed of the motor increases drastically, which is dangerous and thus protection is not possible. This sudden increase in the speed of the motor is known as High-Speed Action of the Motor.

SPEED CONTROL OF DC MOTOR:

The dc motor converts the mechanical power into dc electrical power. One of the most important features of the dc motor is that their speed can easily be control according to the requirement by using simple methods. Such type of control is impossible in an AC motor.

The concept of the speed regulation is different from the speed control. In speed regulation, the speed of the motor changes naturally whereas in dc motor the speed of the motor changes manually

by the operator or by some automatic control device. The speed of the DC Motor is given by the relation shown below.

The equation (1) that the speed is dependent upon the supply voltage V , the armature circuit resistance R_a and the field flux ϕ , which is produced by the field current.

$$N = \frac{V - I_a R_a}{k\phi} \dots \dots \dots (1)$$

For controlling the speed of DC Motor, the variation in voltage, armature resistance and field flux is taken into consideration. There are three general methods of speed control of a DC Motor. They are as follows.

1. Variation of resistance in the armature circuit. This method is called Armature Resistance or Rheostatic control.
2. Variation in field flux. This method is known as Field Flux Control.
3. Variation in applied voltage. This method is also known as Armature Voltage Control.

Armature Resistance Control of DC Motor:

Shunt Motor:

The connection diagram of a shunt motor of the armature resistance control method is shown below. In this method, a variable resistor R_e is put in the armature circuit. The variation in the variable resistance does not effect the flux as the field is directly connected to the supply mains.

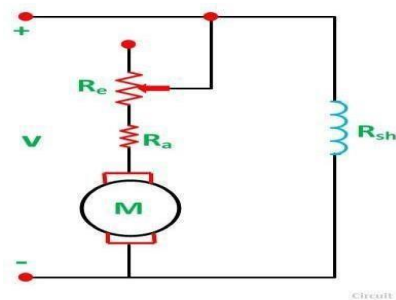

Fig: Connection diagram of a shunt motor of the armature resistance control method

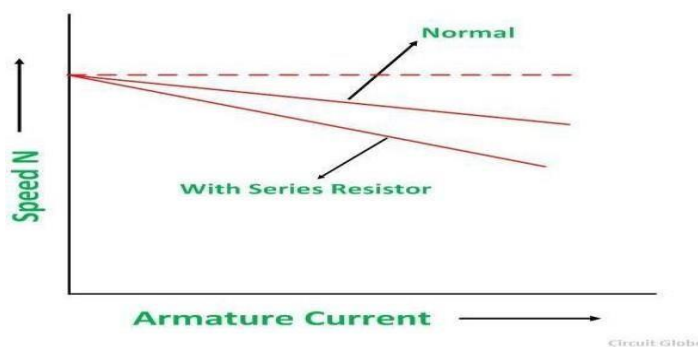

Fig: Speed current characteristic of the shunt motor **Series**

Motor:

Now, let us consider a connection diagram of speed control of the DC Series motor by the armature resistance control method.

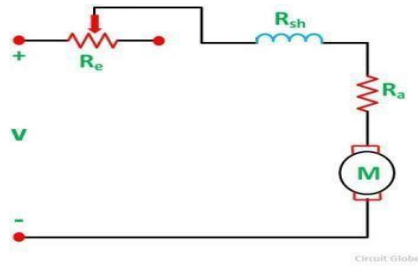

Fig: Diagram of speed control of the DC Series motor

By varying the armature circuit resistance, the current and flux both are affected. The voltage drop in the variable resistance reduces the applied voltage to the armature, and as a result, the speed of the motor is reduced.

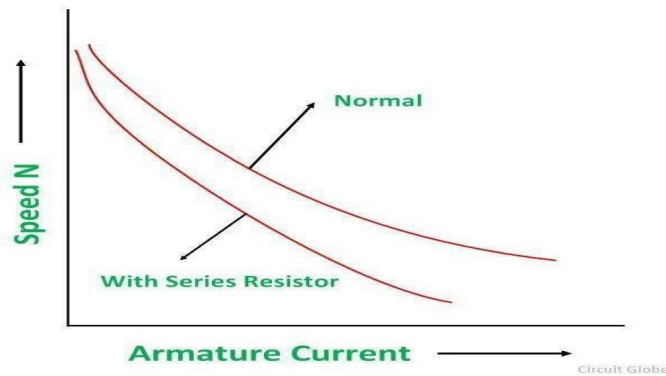

Fig: Speed–current characteristic of a series motor

When the value of variable resistance R_e is increased, the motor runs at a lower speed. Since the variable resistance carries full armature current, it must be designed to carry continuously the full armature current

Disadvantages of Armature Resistance Control Method

- A large amount of power is wasted in the external resistance R_e . □
- Armature resistance control is restricted to keep the speed below the normal speed of the motor and increase in the speed above normal level is not possible by this method. □
- For a given value of variable resistance, the speed reduction is not constant but varies with the motor load. □
- This speed control method is used only for small motors □

Field Flux Control Method of DC Motor :

Flux is produced by the field current. Thus, the speed control by this method is achieved by control of the field current.

Shunt Motor

In a Shunt Motor, the variable resistor R_C is connected in series with the shunt field windings as shown in the figure below. This resistor R_C is known as a Shunt Field Regulator.

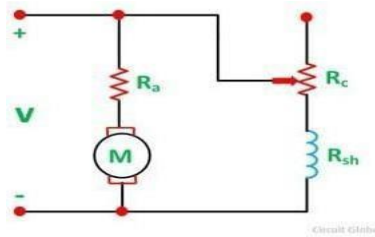

Fig: Shunt Field Regulator

The shunt field current is given by the equation

$$I_{sh} = \frac{V}{R_{sh} + R_C}$$

The connection of RC in the field reduces the field current, and hence the flux is also reduced. This reduction in flux increases the speed, and thus, the motor runs at speed higher than the normal speed. Therefore, this method is used to give motor speed above normal or to correct the fall of speed because of the load.

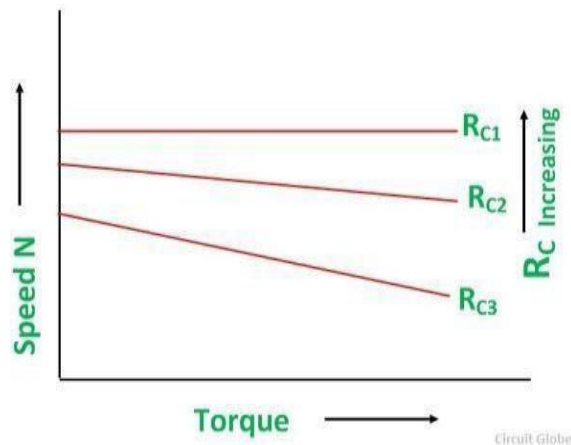

Fig: speed-torque curve for shunt motor

Series Motor

In a series motor, the variation in field current is done by any one method, i.e. either by a diverter or by a tapped field control.

a. By Using a Diverter:

A variable resistance R_d is connected in parallel with the series field windings

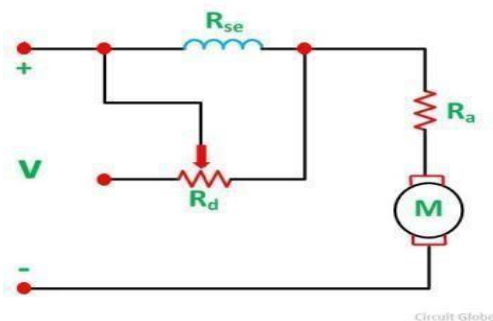

Fig: Diverter is connected in parallel with the series field windings

The parallel resistor is called a Diverter. A portion of the main current is diverted through a variable resistance R_d . Thus, the function of a diverter is to reduce the current flowing through the field winding. The reduction in field current reduces the amount of flux and as a result the speed of the motor increases.

b. Tapped Field Control:

The second method used in a series motor for the variation in field current is by tapped field control. The connection diagram is shown below.

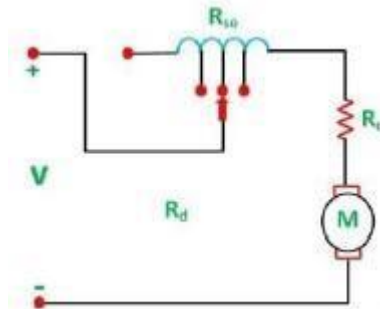

Fig: Tapped Field Control

Here the ampere turns are varied by varying the number of field turns. This type of arrangement is used in an electric traction system. The speed of the motor is controlled by the variation of the field flux. The speed-torque characteristic of a series motor is shown below.

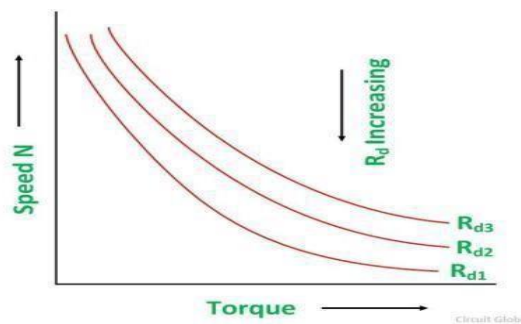

Fig: Speed-torque characteristic

Advantages of Field Flux Control

The following are the advantages of the field flux control method.

- This method is easy and convenient.□
- As the shunt field is very small, the power loss in the shunt field is also small.□

The flux cannot usually be increased beyond its normal values because of the saturation of the iron. Therefore, speed control by flux is limited to the weakening of the field, which gives an increase in speed. This method is applicable over only to a limited range because if the field is weakened too much, there is a loss of stability.

Determination of Efficiency:

Swinburne’s Test:

Swinburne’s Test is an indirect method of testing of DC machines. In this method the losses are measured separately and the efficiency at any desired load is predetermined. Machines are tested for

finding out losses, efficiency and temperature rise. For small machines direct loading test is performed. For large shunt machines, indirect methods are used like Swinburne's or Hopkinson's test.

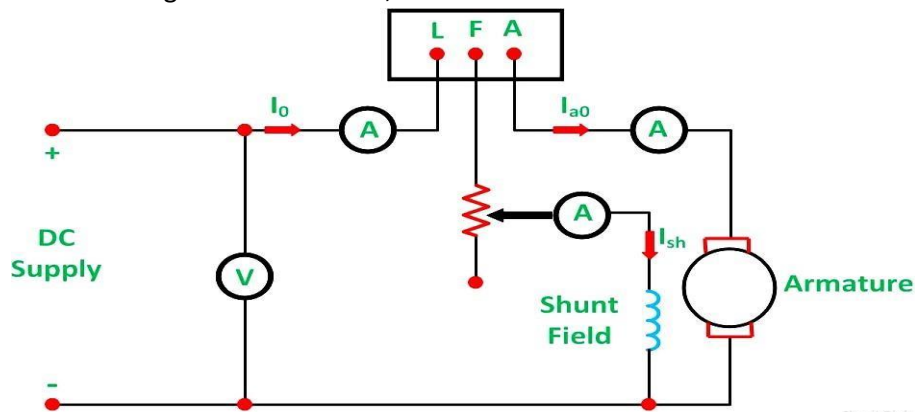

Fig: Swinburne's Test

Let

V be the supply voltage

I_0 is the no-load current

I_{sh} is the shunt field current

Therefore, no load armature current is given by the equation

$$I_{a0} = I_0 - I_{sh}$$

No-load input = $V I_0$

The no-load power input to the machine supplies the following, as given below.

- i. Iron loss in the core
- ii. Friction losses in the bearings and commutators.
- iii. Windage loss iv. Armature copper loss at no load.

When the machine is loaded, the temperature of the armature winding and the field winding increases due to I^2R losses. For calculating I^2R losses hot resistances should be used. A stationary measurement of resistances at room temperature of t degree Celsius is made by passing current through the armature and then field from a low voltage DC supply. Then the heated resistance, allowing a temperature rise of 50°C is found. The equations are as follows:-

$$R_{t1} = R_0 (1 + \alpha_0 t_1)$$

$$R_{t1+50^\circ} = R_0 [1 + \alpha_0 (t_1 + 50^\circ)]$$

Where, α_0 is the temperature coefficient of resistance at 0°C Therefore,

$$R_{t1+50^\circ} = R_{t1} \frac{1 + \alpha_0 (t_1 + 50^\circ)}{1 + \alpha_0 t_1}$$

Stray loss = iron loss + friction loss + windage loss

= input at no load – field copper loss – no load armature copper loss

$$= V I_0 - P_f - P_{a0} = P_s$$

Also, constant losses

$$P_c = \text{no load input} - \text{no load armature copper loss}$$

$$P_c = P_s + P_f$$

If the constant losses of the machine are known, its efficiency at any other load can be determined as follows.

Let

I be the load current at which efficiency is required.

Efficiency when the machine is running as a Motor

$$\text{Motor input} = VI$$

$$\text{Armature copper loss} = I_a^2 R_a = (I - I_{sh})^2 R_a$$

$$\text{Constant losses} = P_c$$

Therefore, total losses is given as

$$\text{Total losses} = (I - I_{sh})^2 R_a + P_c$$

The efficiency of the motor is given by

$$\eta_m = \frac{\text{input} - \text{losses}}{\text{input}}$$

$$\eta_m = \frac{VI - (I - I_{sh})^2 R_a + P_c}{VI}$$

Efficiency when the machine is running as a Generator

$$\text{Generator output} = VI$$

$$\text{Armature current} = I_a = I + I_{sh}$$

$$\text{Armature copper loss} = (I + I_{sh})^2 R_a$$

$$\text{Constant losses} = P_c$$

Therefore, total losses is given as

$$\text{Total losses} = (I + I_{sh})^2 R_a + P_c$$

The efficiency of the generator is given below

$$\eta_g = \frac{\text{output}}{\text{output} + \text{losses}}$$

$$\eta_g = \frac{VI}{VI + (I + I_{sh})^2 R_a + P_c}$$

Advantages of Swinburne's Test:

The main advantages of the Swinburne's test are as follows:-

- The power required to test a large machine is small. Thus, this method is an economical and convenient method of testing of DC machines.
- As the constant loss is known the efficiency can be predetermined at any load.

Disadvantages of Swinburne's Test:

- Change in iron loss is not considered at full load from no load. Due to armature reaction flux is distorted at full load and, as a result, iron loss is increased.

- As the Swinburne's test is performed at no load. Commutation on full load cannot be determined whether it is satisfactory or not and whether the temperature rise is within the specified limits or not.

Limitations of Swinburne's Test:

- Machines having a constant flux are only eligible for Swinburne's test. For examples – shunt machines and level compound generators.
- Series machines cannot run on light loads, and the value of speed and flux varies greatly. Thus, the Swinburne's Test are not applicable for series machines

Brake Test on Dc Shunt Motor:

Brake test is a method of finding efficiency of dc motors. We took dc shunt motor as running machine. Brake test also called as direct loading test of testing the motor because loading will be applied directly on shaft of the motor by means of a belt and pulley arrangement.

Test Requirements:

1. DC shunt motor
2. Water-cooled pulley
3. Spring balance

Procedure of Brake Test on DC Shunt Motor:

1. By adjusting the handle of the pulley take different readings of the spring balance.
2. The tension in the belt can be adjusted using the handle. The tension in kg can be obtained from the spring balance readings.
3. Adjusting the load step by step till full load, number of readings can be obtained. By increasing the load is slowly, adjust to get rated load current.
4. The power developed gets wasted against the friction between belt and shaft. Due to the braking action of belt the test is called brake test.
5. The speed can be measured by tachometer. Thus all the motor characteristics can be plotted.

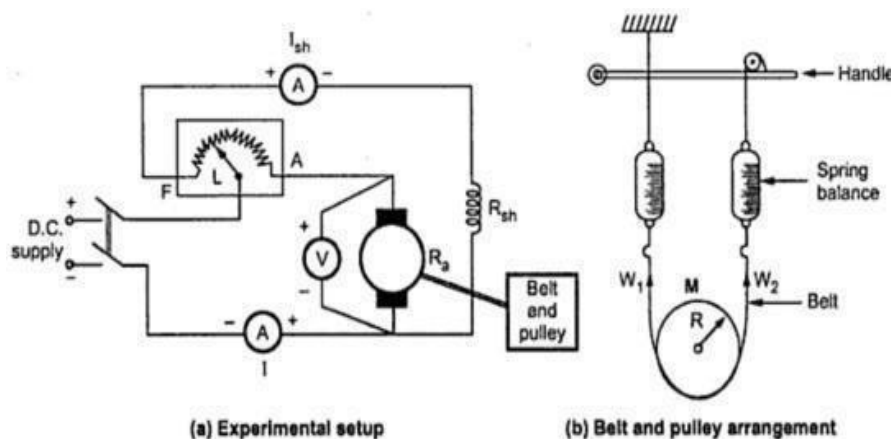

Calculation of Brake Test on DC Shunt Motor :

Let R = Radius of pulley in meters
N = Speed in R.P.M.

W₁ = spring balance reading on tight side in kg
W₂ = spring balance reading on slack side in kg

So, net pull on the belt due to friction at the pulley is the difference between the two spring balance readings.

$$\text{Net pull on the rope} = (W - S) \text{ kg} = (W - S) \times 9.81 \text{ newtons} \dots\dots (1)$$

As radius R and speed N are known, the shaft torque developed can be obtained as, Tsh

$$= \text{Net pull} \times R = (W - S) \times 9.81 \times R \dots\dots (2)$$

Now let, V = Voltage applied in volts

I = Total line current drawn in amps.

As we know V and I are input parameters of dc motors in brake test.

Then,

$$P_{in} = V \cdot I \text{ Watts} \dots\dots (3)$$

Efficiency (η) = Output/Input

From equation (2) & (3)

$$\text{Output power} = \frac{2\pi N T_{sh}}{60} = \frac{2\pi N \times (W - S) \times 9.81 \times r}{60} \text{ watts}$$

Advantages of Brake Test on DC Shunt Motor:

- Actual efficiency of the motor under working conditions can be found out.
- Brake test is simple and easy to perform.
- It is not only for dc shunt motor, also can be performed on any type of D.C. motor.

Disadvantages of Brake Test on DC Shunt Motor:

- In brake test due to the belt friction a lot of heat will be generated and hence there is large dissipation of energy.
- Cooling arrangement is necessary to minimize the heat. Mostly in our laboratories we use water as cooling liquid.
- Convenient only for small rated machines due to limitations regarding heat dissipation arrangements.
- Power developed gets wasted hence brake test method is little expensive.
- The efficiency observed is on the lower side.

Applications of DC Motor:

Applications of DC shunt Motor:

These motors are constant speed motors, hence used in applications requiring constant speed. □

Lathe machine

- Drilling machine
- Grinders
- Blowers
- Compressors

Applications of DC series Motor:

These motors are useful in applications where starting torque required is high and quick acceleration.

Like:

- Traction
- Hoists and Lifts
- Crane
- Rolling mills
- Conveyors

Applications of Cummulative Compound Motor

These motors have high starting torque.They can be operated even at no loads as they run at a moderately high speed at no load.

- Rolling mills
- Punches
- Shears
- Planers

SINGLE PHASE TRANSFORMERS

SINGLE PHASE TRANSFORMERS

WORKING PRINCIPLE OF A TRANSFORMER:

The basic principle on which the transformer works is **Faraday's Law of Electromagnetic Induction** or mutual induction between the two coils. The working of the transformer is explained below. The transformer consists of two separate windings placed over the laminated silicon steel core. The winding to which AC supply is connected is called primary winding and to which load is connected is called secondary winding as shown in the figure below. It works on the alternating current only because an alternating flux is required for mutual induction between the two windings.

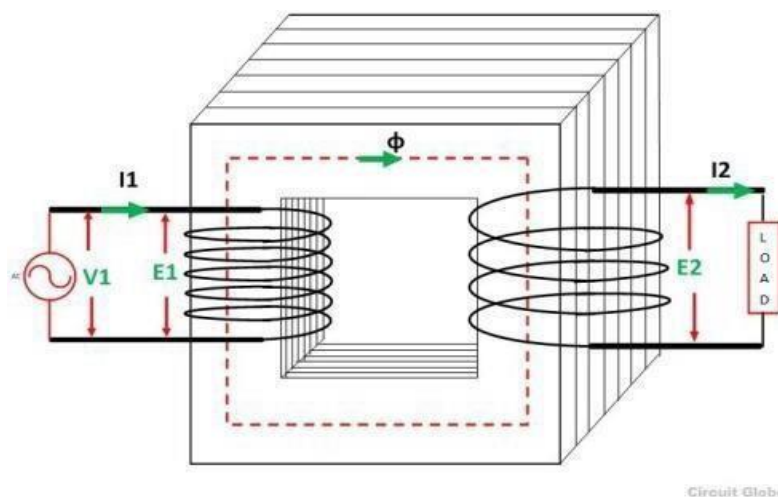

When the AC supply is given to the primary winding with a voltage of V_1 , an alternating flux ϕ sets up in the core of the transformer, which links with the secondary winding and as a result of it, an emf is induced in it called Mutually Induced emf. The direction of this induced emf is opposite to the applied voltage V_1 , this is because of the Lenz's law.

Physically, there is no electrical connection between the two windings, but they are magnetically connected. Therefore, the electrical power is transferred from the primary circuit to the secondary circuit through mutual inductance. The induced emf in the primary and secondary windings depends upon the rate of change of flux linkage that is $(N \frac{d\phi}{dt})$.

$\frac{d\phi}{dt}$ is the change of flux and is same for both the primary and secondary windings. The induced emf E_1 in the primary winding is proportional to the number of turns N_1 of the primary windings ($E_1 \propto N_1$). Similarly induced emf in the secondary winding is proportional to the number of turns on the secondary side. ($E_2 \propto N_2$).

Turn Ratio:

It is defined as the ratio of primary to secondary turns.

$$\text{Turn ratio} = \frac{N_1}{N_2}$$

If $N_2 > N_1$ the transformer is called Step up transformer

If $N_2 < N_1$ the transformer is called Step down transformer

Transformation Ratio:

The transformation ratio is defined as the ratio of the secondary voltage to the primary voltage. It is denoted by K .

$$K = \frac{E_2}{E_1} = \frac{N_2}{N_1}$$

Constructional Details

Depending upon the manner in which the primary and secondary windings are placed on the core, and the shape of the core, there are two types of transformers, called (a) core type, and (b) shell type.

1. Core Type Transformers : In this type of transformer the windings surround the iron core. Both the windings are divided and half of each winding is placed on each limb. In such an arrangement only one layer of high voltage insulation is required.
2. Shell Type Transformers: Both primary and secondary windings are wound on the central limb. In this type of transformer the iron core surrounds the copper windings. The entire flux passes through the central part of iron core, but outside this central core it divides into two parts half going in each direction. In this manner, the leakage flux is reduced to very small value. To minimise the amount of high voltage insulation low voltage coils are placed adjacent to the iron core.

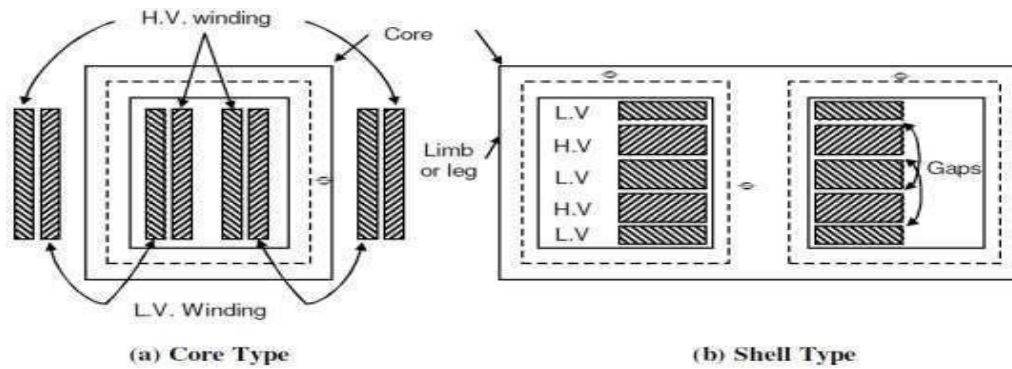

Comparison between core type and shell type transformer

Sl.No.	Core Type Transformer	Shell Type Transformer
1.	The winding surrounds a part of core.	The core surrounds a considerable part of the winding.
2.	It has a single magnetic circuit.	It has a double magnetic circuit.
3.	More suitable for high voltage.	More suitable for low voltage.
4.	The core has two limbs.	The core has three limbs.
5.	The cylindrical coils are used.	Sandwich type coils are used.
6.	Mean length of coil is shorter.	Mean length of coil is longer.
7.	Natural cooling is more effective because windings are distributed on two limbs	Natural cooling is poor because windings limbs are placed on central limb only.
8.	The coil can be easily removed for maintenance.	When coil is removed for repairs, a large number of laminations are to be dismantled.

Different Parts of a Transformer:

The transformer with its different parts and accessories is shown in fig below

- There are two inductive coils of super-enamelled copper wire for primary and secondary windings. The two-windings are insulated from the core and from each other. The coils used are former wound.
- Laminated Steel Core:** The core of transformer is made of thin silicon steel laminations insulated from each other by a thin coat of varnish. The eddy current loss is minimized by laminating the core. The thickness of laminations or stampings varies from 0.35 mm to 0.5 mm. The iron core is rectangular in cross-section for small size transformers and circular for large size transformers to reduce the quantity of copper required.
- Housing:** Assembled transformers are generally housed in tightly fitted sheet metal tanks filled with special insulating oil, known as transformer oil. The insulating oil serves two purposes:
 - Cooling of coils and core.
 - Insulating property.
The insulating oil used with a transformer should have high dielectric strength, low viscosity to provide good heat transfer and good resistance to emulsion.
 - Sides of steel tanks are corrugated on both sides to increase the cooling surface area.

4. **Bushings:** To insulate and to bring out the terminals of the transformer from the container, bushings are used. Bushings are of three types:
 - a. Porcelain bushings used for low voltage transformers.
 - b. Oil-filled bushings used for voltage upto 33 kV.
 - c. Condenser-type bushings used for voltages above 33 kV.
5. **Conservator:** It is also called as expansion tank. It is a drum containing transformer oil and mounted at the top of the transformer and connected to the main tank by a pipe. The main tank is completely filled with oil but conservator tank is partially filled with oil. As the volume of oil of transformer tank expands and contracts according to heat produced, this expansion and contraction of oil causes the level of the oil in conservator to rise and fall. The aim of conservator is to maintain the oil level in tank and provides space for the expansion of oil.
6. **Breather:** It is attached to conservator tank and contains silica gel, which prevents the moist air from entering into the tank during contraction of oil. When oil is hot there is expansion and gas passes to atmosphere through it. When oil is cooled, it contracts and the air enters in it. It prevents transformer oil from moisture contamination.
7. **Temperature Gauge:** Every transformer is provided with a temperature gauge to indicate the temperature of the hot oil in the transformer tank.
8. **Oil gauge:** Every transformer is provided with an oil gauge to indicate the oil level. The oil gauge may be provided with the alarm contacts which gives an alarm when the oil has dropped below permissible height due to oil leak etc.
9. **Gas-Operated-Relay: (Buchholz Relay)** It is protective relay of transformer. This device signals the fault as soon as it occurs and cuts the transformer out of the circuit immediately. This is gas operated protective relay. It is connected between the main tank and conservator tank. This relay works on the formation of excessive oil vapours or gas inside the transformer tank due to internal fault of transformer.
10. **Tappings:** The transformers are usually provided with few tappings on secondary side so that output voltage can be varied for constant input voltage.
11. **Radiators:** Due to losses in the transformers, the oil near the windings gets heated and travels towards the top of the tank. In large capacity transformers of about 50 kVA and above this increase in the oil temperature is quite high. To dissipate this heat, radiators are provided in the transformers. The radiators increase the surface area of the tank and thus more heat is radiated in short time.

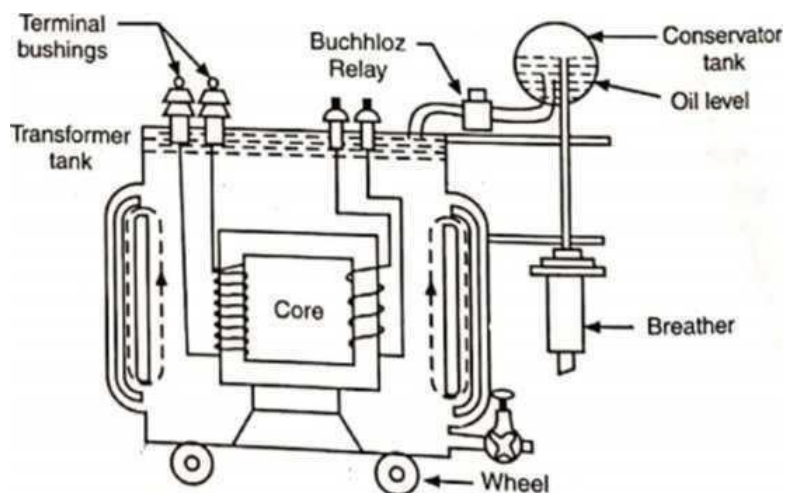

Cooling Methods of a Transformer

No transformer is truly an 'ideal transformer' and hence each will incur some losses, most of which get converted into heat. If this heat is not dissipated properly, the excess temperature in transformer may cause serious problems like insulation failure. So the transformer needs a cooling system. Transformers can be divided in two types as (i) dry type transformers and (ii) oil immersed transformers. Different cooling methods of transformers are –

For dry type transformers

1. Air Natural (AN)
2. Air Blast

For oil immersed Transformers

1. Oil Natural Air Natural (ONAN)
2. Oil Natural Air Forced (ONAF)
3. Oil Forced Air Forced (OFAF)
4. Oil Forced Water Forced (OFWF)

Cooling methods for Dry type Transformers

1. **Air Natural or Self air cooled transformer:**

This method of transformer cooling is generally used in small transformers (upto 3 MVA). In this method the transformer is allowed to cool by natural air flow surrounding it.

2. **Air Blast :**

For transformers rated more than 3 MVA, cooling by natural air method is inadequate. In this method, air is forced on the core and windings with the help of fans or blowers. The air supply must be filtered to prevent the accumulation of dust particles in ventilation ducts. This method can be used for transformers upto 15 MVA.

Cooling methods for Oil Immersed Transformers

1. **Oil Natural Air Natural (ONAN)**

This method is used for oil immersed transformers. In this method, the heat generated in the core and winding is transferred to the oil. According to the principle of convection, the heated oil flows in the upward direction and then in the radiator. The vacant place is filled up by cooled oil from the radiator. The heat from the oil will dissipate in the atmosphere due to the natural air flow around the transformer. In this way, the oil in transformer keeps circulating due to natural convection and dissipating heat in atmosphere due to natural conduction. This method can be used for transformers upto about 30 MVA.

2. **Oil Natural Air Forced (ONAF)**

The heat dissipation can be improved further by applying forced air on the dissipating surface. Forced air provides faster heat dissipation than natural air flow. In this method, fans are mounted near the radiator and may be provided with an automatic starting arrangement, which turns on when temperature increases beyond certain value. This transformer cooling method is generally used for large transformers upto about 60 MVA.

3. Oil Forced Air Forced (OFAF)

In this method, oil is circulated with the help of a pump. The oil circulation is forced through the heat exchangers. Then compressed air is forced to flow on the heat exchanger with the help of fans. The heat exchangers may be mounted separately from the transformer tank and connected through pipes at top and bottom. This type of cooling is provided for higher rating transformers at substations or power stations.

4. Oil Forced Water Forced (OFWF)

This method is similar to OFAF method, but here forced water flow is used to dissipate heat from the heat exchangers. The oil is forced to flow through the heat exchanger with the help of a pump, where the heat is dissipated in the water which is also forced to flow. The heated water is taken away to cool in separate coolers. This type of cooling is used in very large transformers having rating of several hundreds MVA.

EMF EQUATION OF A TRANSFORMER:

When a sinusoidal voltage is applied to the primary winding of a transformer, alternating flux ϕ_m sets up in the iron core of the transformer. This sinusoidal flux links with both primary and secondary winding.

The function of flux is a sine function. The rate of change of flux with respect to time is derived mathematically.

- ϕ_m be the maximum value of flux in Weber
- f be the supply frequency in Hz
- N_1 is the number of turns in the primary winding
- N_2 is the number of turns in the secondary winding Φ is the flux per turn in Weber

Let E_1 is the emf induced in the primary winding

$$E_1 = - \frac{d\psi}{dt} \dots \dots \dots (1)$$

Where $\psi = N_1\phi$

$$\text{Therefore, } E_1 = -N_1 \frac{d\phi}{dt} \dots \dots \dots (2)$$

Since ϕ is due to AC supply $\phi = \phi_m \sin \omega t$

$$E_1 = -N_1 \frac{d}{dt} (\phi_m \sin \omega t)$$

$$E_1 = -N_1 \omega \phi_m \cos \omega t$$

$$E_1 = N_1 \omega \phi_m \sin(\omega t - \pi/2) \dots \dots \dots (3)$$

So the induced emf lags flux by 90 degrees.

Maximum value of emf

$$E_1 \max = N_1 \omega \phi_m \dots \dots \dots (4)$$

But $\omega = 2\pi f$

$$E_1 \max = 2\pi f N_1 \phi_m \dots \dots \dots (5)$$

Root mean square RMS value is

$$E_1 = \frac{E_{1\max}}{\sqrt{2}} \dots \dots \dots (6)$$

Putting the value of $E_{1\max}$ in equation (6) we get

$$E_1 = \sqrt{2\pi f N_1 \phi_m} \dots \dots \dots (7)$$

Putting the value of $\pi = 3.14$ in the equation (7) we will get the value of E_1 as

$$E_1 = 4.44 f N_1 \phi_m \dots \dots \dots (8)$$

Similarly

$$E_2 = \sqrt{2\pi f N_2 \phi_m}$$

Or

$$E_2 = 4.44 f N_2 \phi_m \dots \dots \dots (9)$$

Now, equating the equation (8) and (9) we get

$$\frac{E_2}{E_1} = \frac{4.44 f N_2 \phi_m}{4.44 f N_1 \phi_m}$$

Or

$$\frac{E_2}{E_1} = \frac{N_2}{N_1} = K$$

The equation (8) and (9) can also be written as shown below using the relation ($\phi_m = B_m \times A_i$) where A_i is the iron area and B_m is the maximum value of flux density.

$$E_1 = 4.44 N_1 f B_m A_i \text{ Volts} \quad \text{and} \quad E_2 = 4.44 N_2 f B_m A_i \text{ Volts}$$

Ideal Transformer:

Definition: The transformer which is free from all types of losses is known as an ideal transformer. It is an imaginary transformer which has no core loss, no ohmic resistance and no leakage flux. The ideal transformer has the following important characteristic.

1. The resistance of their primary and secondary winding becomes zero.
2. The core of the ideal transformer has infinite permeability. The infinite permeable means less magnetising current requires for magnetising their core.
3. The leakage flux of the transformer becomes zero, i.e. the whole of the flux induces in the core of the transformer links with their primary and secondary winding.
4. The ideal transformer has 100 percent efficiency, i.e., the transformer is free from hysteresis and eddy current loss.

The above mention properties are not possible in the practical transformer. In an ideal transformer, there is no power loss. Therefore, the output power is equal to the input power.

$$E_2 I_2 \cos\phi = E_1 I_1 \cos\phi \quad \text{or} \quad E_2 I_2 = E_1 I_1$$

OR

$$\frac{E_2}{E_1} = \frac{I_1}{I_2}$$

$$\frac{V_2}{V_1} = \frac{E_2}{E_1} = \frac{N_2}{N_1} = \frac{I_1}{I_2} = K$$

Behaviour of Ideal Transformer:

Consider the ideal transformer shown in the figure below. The voltage source V_1 is applied across the primary winding of the transformer. Their secondary winding is kept open. The N_1 and N_2 are the numbers of turns of their primary and secondary winding.

The current I_m is the magnetizing current flows through the primary winding of the transformer. The magnetizing current produces the flux ϕ_m in the core of the transformer. As the permeability of the core is infinite, the flux of the core link with both the primary and secondary winding of the transformer.

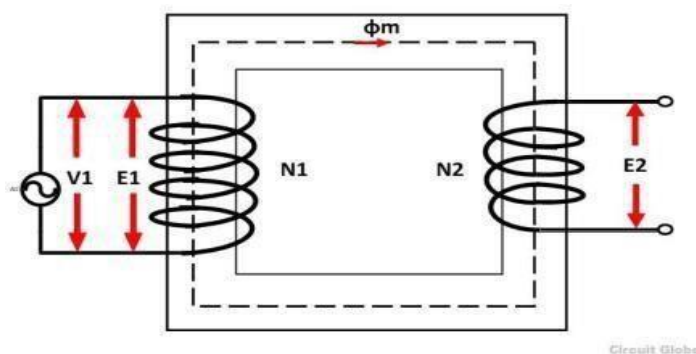

The flux link with the primary winding induces the emf E_1 because of self-induction. The direction of the induced emf is inversely proportional to the applied voltage V_1 . The emf E_2 induces in the secondary winding of the transformer because of mutual induction.

Phasor Diagram of Ideal Transformer:

As the coil of the primary transformer is purely inductive the magnetising current induces in the transformer lag 90° by the input voltage V_1 . The E_1 and E_2 are the emf induced in the primary and secondary winding of the transformer. The direction of the induces emf inversely proportional to the applied voltage.

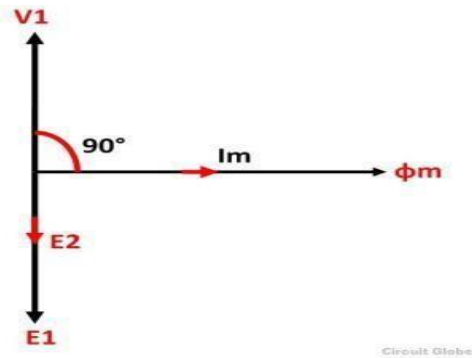

Transformer with Resistance and Leakage Reactance

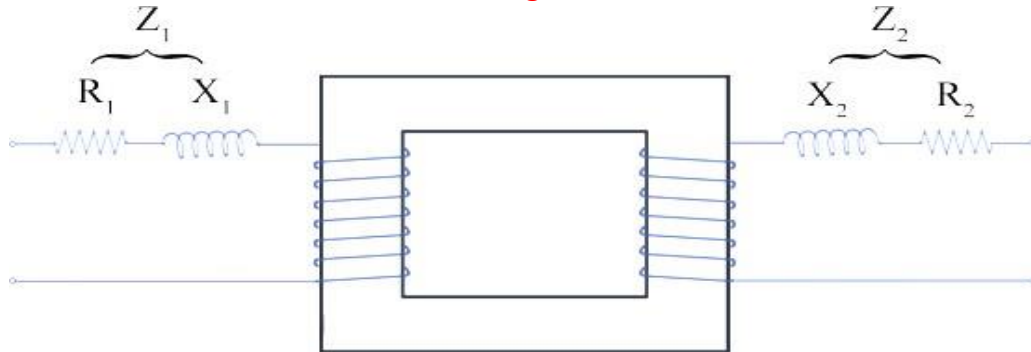

Where, R_1 and R_2 = resistance of primary and secondary winding respectively
and X_1 and X_2 = **leakage reactance** of primary and secondary winding respectively. Z_1
and Z_2 = Primary impedance and secondary impedance respectively.

$$Z_1 = R_1 + jX_1 \text{ ...and } Z_2 = R_2 + jX_2 .$$

The impedance in each winding lead to some voltage drop in each winding. Considering this voltage drop the **voltage equation of transformer** can be given as – $V_1 = E_1 + I_1(R_1 + jX_1)$ -----
primary side

$$V_2 = E_2 - I_2(R_2 + jX_2) \text{ ----- secondary side}$$

where, V_1 = supply voltage of primary winding

V_2 = terminal voltage of secondary winding

E_1 and E_2 = induced emf in primary and secondary winding respectively.

Resistance and Reactance of the Transformer:

The primary and the secondary windings have some resistance represented by R_1 and R_2 and the reactances by X_1 and X_2 . Let K be the transformation ratio.

To make the calculations easy the resistances and reactances can be transferred to either side that means either all the primary terms are referred to the secondary side, or all the secondary terms are referred to the primary side.

The resistive and the reactive drops in the primary and secondary side are represented as follows

- Resistive drop in the secondary side = $I_2 R_2$
- Reactive drop in the secondary side = $I_2 X_2$
- Resistive drop in the primary side = $I_1 R_1$

- Reactive drop in the primary side = $I_1 X_1$

Primary Side Referred to Secondary Side:

Since the transformation ratio is K , primary resistive and reactive drop as referred to secondary side will be K times, i.e., $K I_1 R_1$ and $K I_1 X_1$ respectively. If I_1 is substituted equal to $K I_2$ then we have primary resistive and reactive drop referred to secondary side equal to $K^2 I_2 R_1$ and $K^2 I_2 X_1$ respectively.

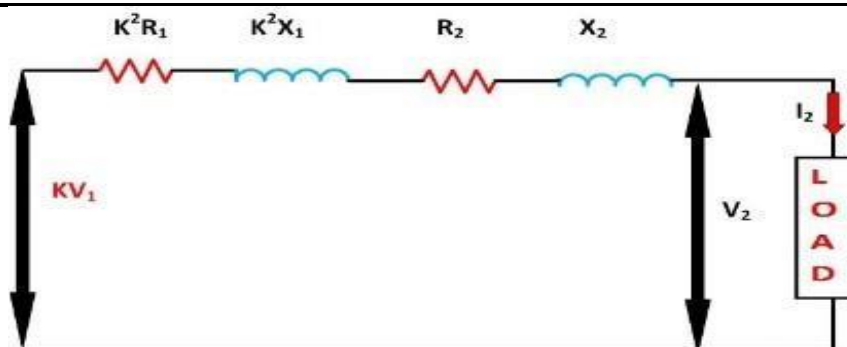

The Total resistive drop in a transformer

$$K^2 I_2 R_1 + I_2 R_2 = I_2 (K^2 R_1 + R_2)$$

Total reactive drop in a transformer

$$K^2 I_2 X_1 + I_2 X_2 = I_2 (K^2 X_1 + X_2)$$

The term

$(K^2 R_1 + R_2)$ And $(K^2 X_1 + X_2)$ represent the equivalent resistance and reactance of the transformer referred to the secondary side.

TRANSFORMER ON NO-LOAD CONDITION:

When the transformer is operating at no load, the secondary winding is open circuited, which means there is no load on the secondary side of the transformer and, therefore, current in the secondary will be zero, while primary winding carries a small current I_0 called no load current which is 2 to 10% of the rated current. This current is responsible for supplying the iron losses (hysteresis and eddy current losses) in the core and a very small amount of copper losses in the primary winding. The angle of lag depends upon the losses in the transformer. The power factor is very low and varies from 0.1 to 0.15.

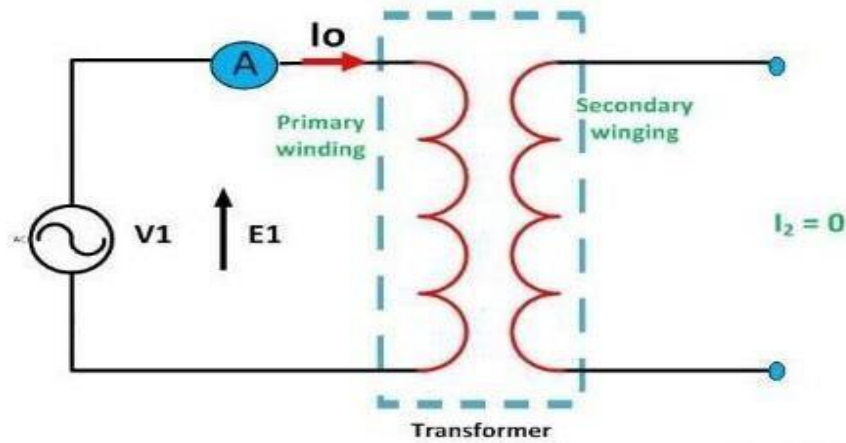

The no load current consists of two components

- Reactive or magnetizing component I_m (It is in quadrature with the applied voltage V_1 . It produces flux in the core and does not consume any power)
- Active or power component I_w , also known as working component (It is in phase with the applied voltage V_1 . It supplies the iron losses and a small amount of primary copper loss)

The following steps are given below to draw the phasor diagram

1. The function of the magnetizing component is to produce the magnetizing flux, and thus, it will be in phase with the flux.
2. Induced emf in the primary and the secondary winding lags the flux ϕ by 90 degrees.
3. The primary copper loss is neglected, and secondary current losses are zero as $I_2 = 0$. Therefore, the current I_0 lags behind the voltage vector V_1 by an angle ϕ_0 called no-load power factor angle shown in the phasor diagram above.
4. The applied voltage V_1 is drawn equal and opposite to the induced emf E_1 because the difference between the two, at no load, is negligible.
5. Active component I_w is drawn in phase with the applied voltage V_1 .
6. The phasor sum of magnetizing current I_m and the working current I_w gives the no load current

I_0 .

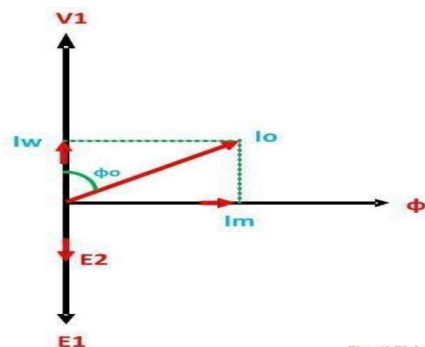

Working component $I_w = I_0 \cos \phi_0$

No load current $I_0 = \sqrt{I_w^2 + I_m^2}$

Magnetizing component $I_m = I_0 \sin \phi_0$

Power factor $\cos \phi_0 = \frac{I_w}{I_0}$

No load power input $P_0 = V_1 I_0 \cos \phi_0$

TRANSFORMER ON LOAD CONDITION:

When the transformer is on loaded condition, the secondary of the transformer is connected to load. The load can be resistive, inductive or capacitive. The current I_2 flows through the secondary winding of the transformer. The magnitude of the secondary current depends on the terminal voltage V_2 and the load impedance. The phase angle between the secondary current and voltage depends on the nature of the load.

Operation of the Transformer on Load Condition

When secondary of the transformer is kept open, it draws the no-load current from the main supply. The no-load current induces the magnetomotive force $N_0 I_0$ and this force set up the flux Φ in the core of the transformer.

When the load is connected to the secondary of the transformer, the I_2 current flows through their secondary winding. The secondary current induces the magnetomotive force $N_2 I_2$ on the secondary winding of the transformer. This force set up the flux Φ_2 in the transformer core. The flux Φ_2 oppose the flux ϕ , according to Lenz's law.

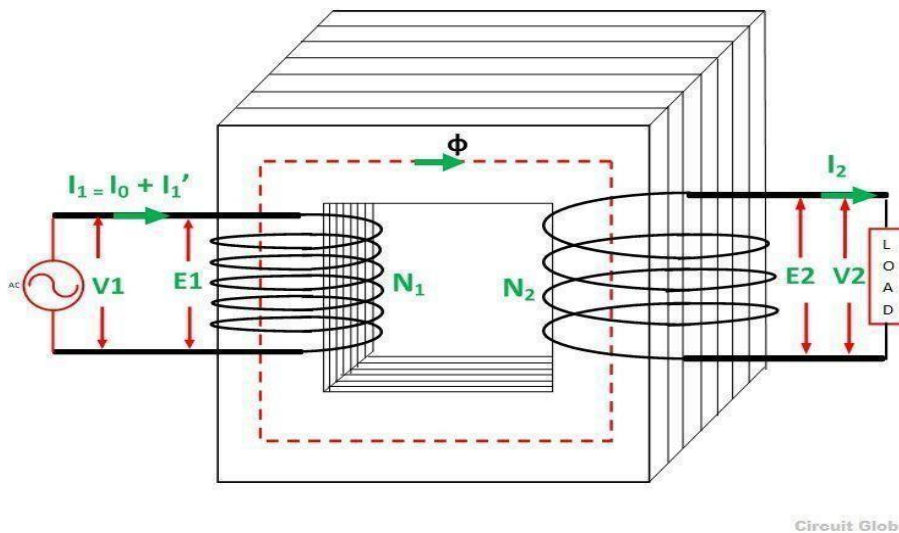

- As the flux Φ_2 opposes the flux ϕ , the resultant flux of the transformer decreases and this flux reduces the induced EMF E_1 . Thus, the strength of the V_1 is more than E_1 and an additional primary current I_1' drawn from the main supply. The additional current is used for restoring the original value of the flux in the core of the transformer so that the $V_1 = E_1$. The primary current I_1' is in phase opposition with the secondary current I_2 . Thus, it is called the primary counter balancing current.
- The additional current I_1' induces the magnetomotive force $N_1 I_1'$. And this force set up the flux Φ_1 . The direction of the flux is same as that of the ϕ and it cancels the flux Φ_2 which induces because of the MMF $N_2 I_2$.

$$\text{Now, } N_1 I_1' = N_2 I_2$$

$$I_1' = \left(\frac{N_2}{N_1} \right) I_2 = K I_2$$

Therefore,

- The phasor difference between V_1 and I_1 gives the power factor angle Φ_1 of the primary side of the transformer.

- The power factor of the secondary side depends upon the type of load connected to the transformer.
- If the load is inductive as shown in the above phasor diagram, the power factor will be lagging, and if the load is capacitive, the power factor will be leading. The total primary current I_1 is the vector sum of the current I_0 and I_1' . i.e

$$\bar{I}_1 = \bar{I}_0 + \bar{I}_1'$$

Phasor Diagram of Transformer on Inductive Load:

The Transformer on Inductive load (lagging power factor load) is shown below in the phasor diagram.

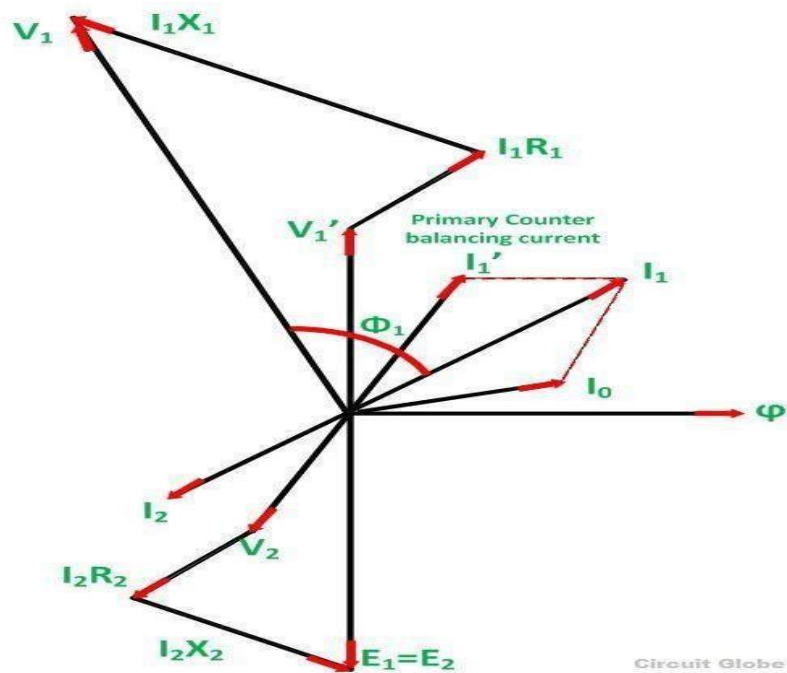

Phasor Diagram of Transformer on Capacitive Load

The Transformer on Capacitive load (leading power factor load) is shown below in the phasor diagram.

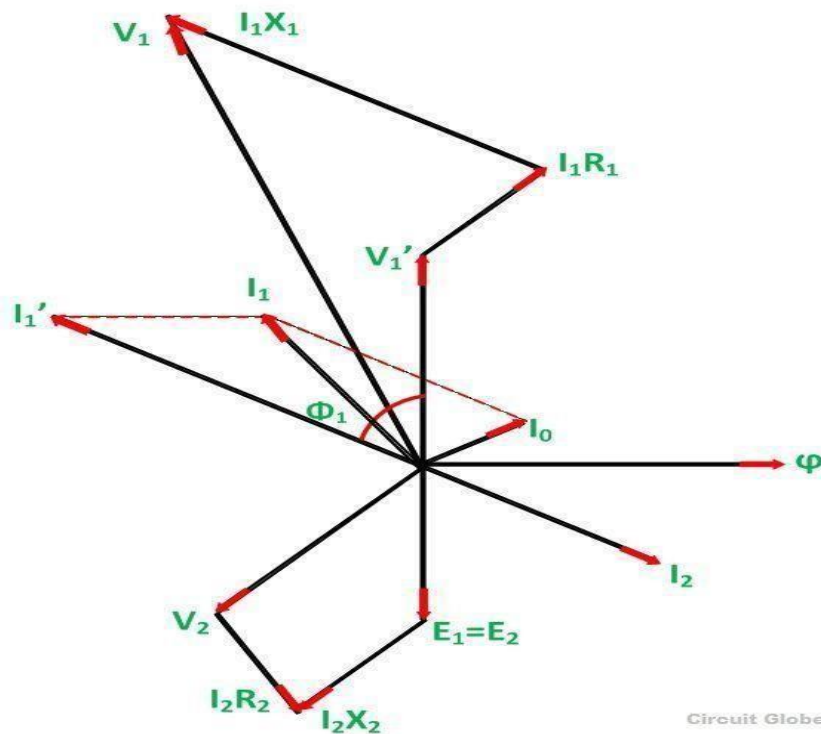

EQUIVALENT CIRCUIT OF A TRANSFORMER:

The equivalent circuit diagram of any device can be quite helpful in predetermination of the behaviour of the device under the various condition of operation. It is simply the circuit representation of the equation describing the performance of the device.

The simplified equivalent circuit of a transformer is drawn by representing all the parameters of the transformer either on the secondary side or on the primary side. The equivalent circuit diagram of the transformer is shown below

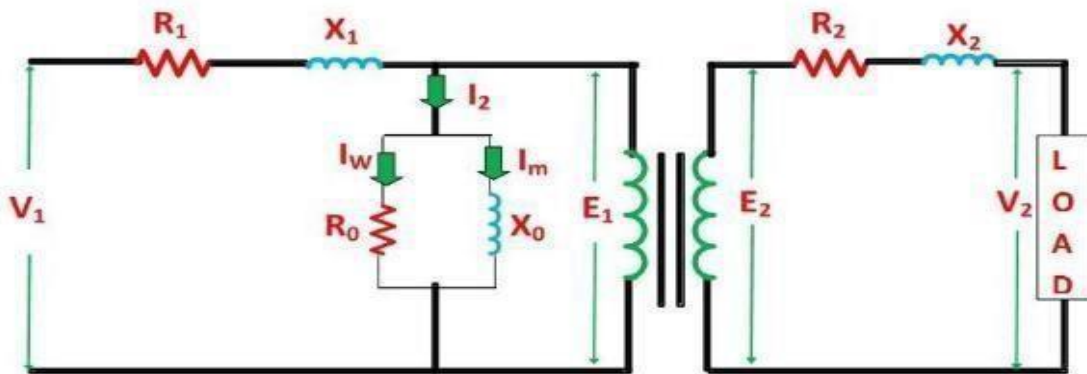

Let the equivalent circuit of a transformer having the transformation ratio $K = E_2/E_1$

The induced emf E_1 is less than applied voltage V_1 . This voltage causes current I_0 no load current in the primary winding of the transformer. The value of no-load current is very small, and thus, it is neglected. Hence, $I_1 = I_1'$. The no load current is further divided into two components called magnetizing current (I_m) and working current (I_w).

These two components of no-load current are due to the current drawn by a noninductive resistance R_0 and pure reactance X_0 having voltage E_1 or (V_1 primary voltage drop).

The secondary current I_2 is

$$I_2 = \frac{I_1'}{K} = \frac{I_1 - I_0}{K}$$

The terminal voltage V_2 across the load is equal to the induced emf E_2 in the secondary winding less voltage drop in the secondary winding.

Equivalent Circuit when all the Quantities are referred to Primary side:

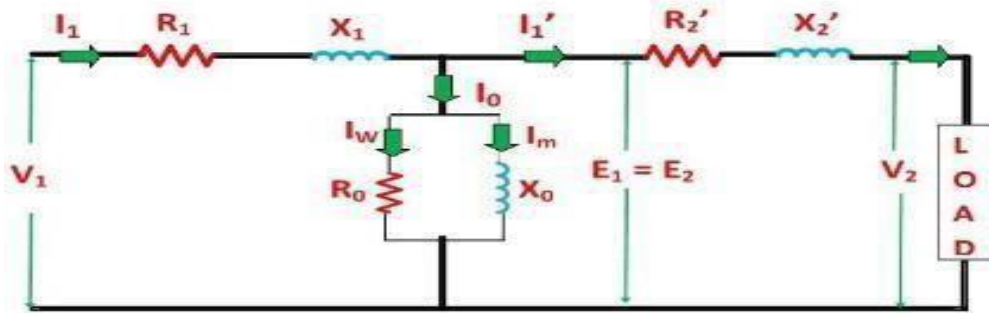

Secondary resistance referred to primary side is given as

$$R_2' = \frac{R_2}{K^2}$$

The equivalent resistance referred to primary side is given as

$$R_{ep} = R_1 + R_2'$$

Secondary reactance referred to primary side is given as

$$X_2' = \frac{X_2}{K^2}$$

The equivalent reactance referred to primary side is given as

$$X_{ep} = X_1 + X_2'$$

Equivalent Circuit when all the Quantities are referred to Secondary side:

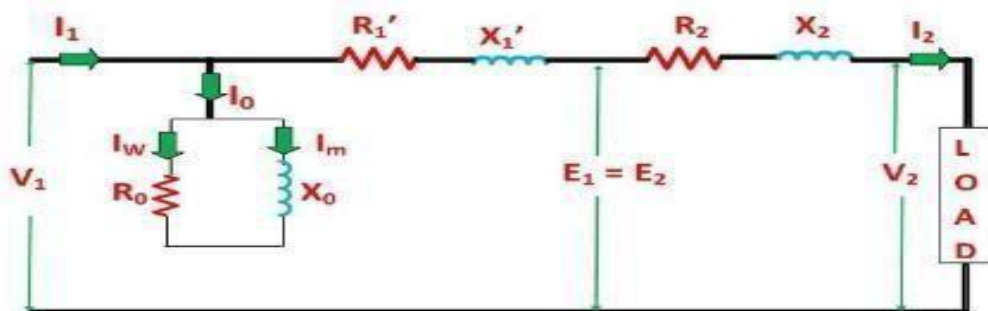

Primary resistance referred to secondary side is given as

$$R_1' = K^2 R_1$$

The equivalent resistance referred to secondary side is given as

$$R_{es} = R_2 + R_1'$$

Primary reactance referred to secondary side is given as

$$X_1' = K^2 X_1$$

The equivalent reactance referred to secondary side is given as

$$X_{eq} = X_2 + X_1'$$

No load current I_0 is hardly 3 to 5% of full load rated current, the parallel branch consisting of resistance R_0 and reactance X_0 can be omitted without introducing any appreciable error in the behavior of the transformer under the loaded condition.

Further simplification of the equivalent circuit of the transformer can be done by neglecting the parallel branch consisting R_0 and X_0 .

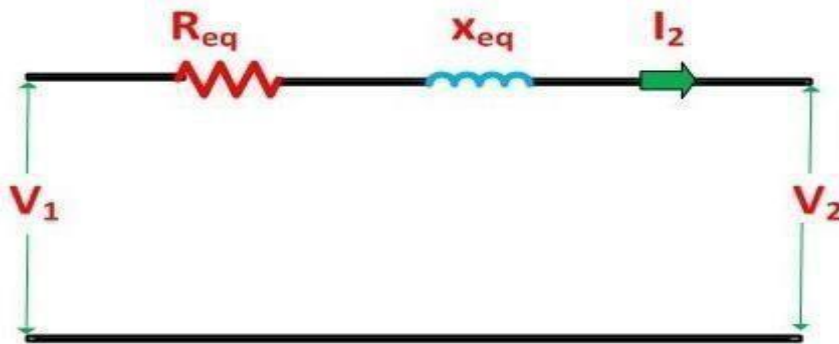

VOLTAGE REGULATION OF A TRANSFORMER:

Definition: The voltage regulation is defined as the change in the secondary terminal voltage from no load to full load voltage of the transformer. The voltage regulation determines the ability of the transformer to provide the constant voltage for variable loads. The voltage regulation is represented as

$$\text{Voltage Regulation} = \frac{E_2 - V_2}{E_2}$$

$$\% \text{ Voltage Regulation} = \frac{E_2 - V_2}{E_2} \times 100$$

Where,

E_2 – secondary terminal voltage at no load

V_2 – secondary terminal voltage at full load

Mathematical Expression For Voltage Regulation:

If the secondary terminals of the transformer are open circuited or no load is connected to the secondary terminals, the no-load current flows through it. If the no current flows through the secondary terminals of the transformer, the voltage drops across their resistive and reactive load become zero. The voltage drop across the primary side of the transformer is negligible.

If the transformer is fully loaded, i.e., the load is connected to their secondary terminal, the voltage drops appear across it. The value of the voltage regulation should always be less for the better performance of transformer.

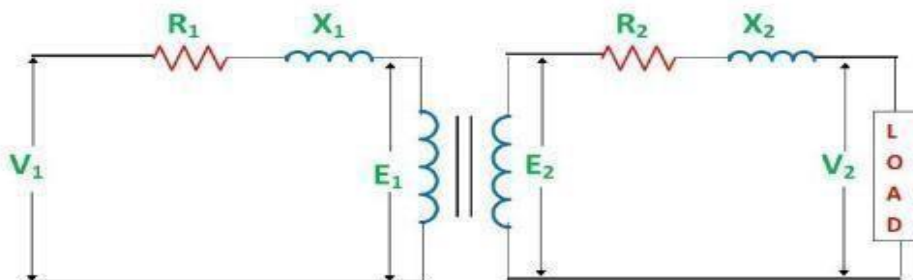

- The primary voltage of the transformer is always greater than the emf induces on the primary side.
 $V_1 > E_1$
- The secondary terminal voltage at no load is always greater than the voltage at full load condition.
 $E_2 > V_2$

By considering the above circuit diagram, the following equations are drawn

$$V_1 = I_1 R_1 \cos\phi_1 + I_1 X_1 \sin\phi_1 + E_1$$

$$E_2 = I_2 R_2 \cos\phi_2 + I_2 X_2 \sin\phi_2 + V_2$$

For inductive load:

$$E_2 = I_2 R_{02} \cos\phi_2 + I_2 X_{02} \sin\phi_2 + V_2$$

OR

$$E_2 - V_2 = I_2 R_{02} \cos\phi_2 + I_2 X_{02} \sin\phi_2$$

OR

$$\frac{E_2 - V_2}{E_2} \times 100 = \frac{I_2 R_{02}}{E_2} \times 100 \cos\phi_2 + \frac{I_2 X_{02}}{E_2} \times 100 \sin\phi_2$$

Where,

$\frac{I_2 R_{02}}{E_2} \times 100$ is a percentage resistance drop

$\frac{I_2 X_{02}}{E_2} \times 100$ is a percentage reactance drop

For Capacitive load:

$$E_2 = I_2 R_{02} \cos\phi_2 - I_2 X_{02} \sin\phi_2 + V_2$$

OR

$$E_2 - V_2 = I_2 R_{02} \cos\phi_2 - I_2 X_{02} \sin\phi_2$$

OR

$$\frac{E_2 - V_2}{E_2} \times 100 = \frac{I_2 R_{02}}{E_2} \times 100 \cos\phi_2 - \frac{I_2 X_{02}}{E_2} \times 100 \sin\phi_2$$

LOSSES IN A TRANSFORMER:

The power losses in a transformer are of two types, namely;

1. Core or Iron losses
2. Copper losses

These losses appear in the form of heat and produce (i) an increase in Temperature and (ii) a drop in efficiency.

Core or Iron losses (Pi)

These consist of hysteresis and eddy current losses and occur in the transformer core due to the alternating flux. These can be determined by open-circuit test. Hysteresis loss

$$W_h = \eta B_m^{1.6} f \text{ atts}$$

Where η = Steinmetz hysteresis co-efficient

B_m = Maximum flux density in Wb/m²

f = Frequency in Hz

V = Volume of the armature core in m³

$$\text{Eddy current loss } W_e = K_e B_m^2 f^2 t^2 V \text{ watts}$$

Where K_e = Constant depending upon the electrical resistance of core

B_m = Maximum flux density in Wb/m²

f = Frequency in Hz

V = Volume of the armature core in m³

t = Thickness of the lamination in meters

Both hysteresis and eddy current losses depend upon

- Maximum flux density B_m in the core
- Supply frequency f . Since transformers are connected to constant-frequency, constant voltage supply, both f and B_m are constant. Hence, core or iron losses are practically the same at all loads.

Iron or Core losses, P_i = Hysteresis loss + Eddy current loss = Constant losses (P_i)

The hysteresis loss can be minimized by using steel of high silicon content Whereas eddy current loss can be reduced by using core of thin laminations.

Copper losses (Pcu)

These losses occur in both the primary and secondary windings due to their ohmic resistance. These can be determined by short-circuit test. The copper loss depends on the magnitude of the current flowing through the windings .

$$\text{Total copper loss} = I_1^2 R_1 + I_2^2 R_2 = I_1^2 (R_1 + R_2) = I_2^2 (R_2 + R_1)$$

$$\text{Total loss} = \text{iron loss} + \text{copper loss} = P_i + P_{cu}$$

EFFICIENCY OF A TRANSFORMER

Like any other electrical machine, the efficiency of a transformer is defined as the ratio of output power (in watts or kW) to input power (watts or kW) i.e.

Power output = power input – Total losses

Power input = power output + Total losses

$$= \text{power output} + P_i + P_{cu}$$

Let V_2, I_2 and $\cos(\phi_2)$ be the secondary terminal voltage, load current and power factor respectively.

Then power output, $P = V_2 I_2 \cos(\phi_2)$

Total copper losses, $P_c \approx I_2^2 R_{02}$

Total losses = $P_i \approx P_c$

Where R_{02} is total resistance referred to secondary side

$$V_2 I_2 \cos \phi_2$$

Transformer efficiency, $\eta = \frac{V_2 I_2 \cos \phi_2 - P_c - I_2^2 R_{02}}{V_2 I_2 \cos \phi_2}$

V_2 is approximately constant for a normal transformer. Hence, for a given power factor, efficiency depends on the load current I_2 .

Condition for Maximum Efficiency

$$\text{Transformer efficiency, } \eta = \frac{V_2 I_2 \cos \phi_2}{\frac{P_i}{2} + \frac{P_c}{2} + I_2^2 R_{02}}$$

It is evident from the above expression for transformer efficiency that numerator is constant and for the efficiency to be maximum, denominator should be minimum.

$$\frac{d}{dI_2} (\text{denominator}) = 0$$

$$\frac{d}{dI_2} \left[\frac{P_i}{2} + \frac{P_c}{2} + I_2^2 R_{02} \right] = 0$$

$$0 + 0 + 2 I_2 R_{02} = 0$$

$$I_2^2 R_{02} = \frac{P_i}{2}$$

$$I_2 = \sqrt{\frac{P_i}{2 R_{02}}} \quad \text{.....(1)}$$

i.e. Copper losses = Iron losses Therefore, efficiency of a transformer is maximum when the copper loss is equal to iron loss.

$$V_2 I_2 \cos \phi_2 = [P_i + P_c]$$

$$\eta_{\max} = \frac{V_2 I_2 \cos \phi_2}{\frac{2P_i}{2} + \frac{2P_c}{2}}$$

From equation (1), the value of output current at which efficiency of transformer will be maximum

I_2 corresponding to maximum efficiency

which efficiency is maximum

$$I_2 \approx \sqrt{\frac{P}{R_{02}}}$$

□

Output KVA corresponding to maximum efficiency.

Let P_c = Copper loss at full load kVA

P_i = Iron loss

X = Fraction of full load kVA
at Total copper loss = $X^2 P_c$

$X^2 P_c = P_i$ for maximum efficiency

$$X \approx \sqrt{\frac{P_i}{P_c}}$$

Output kVA corresponding to maximum efficiency

$$= X \times \text{full load kVA} = \text{full load kVA} \sqrt{\frac{\text{Iron loss}}{\text{Copper loss}}}$$

OPEN CIRCUIT AND SHORT CIRCUIT TEST ON TRANSFORMER

The open circuit and short circuit test are performed for determining the parameter of the transformer like their efficiency, voltage regulation, circuit constant etc. These tests are performed without the actual loading and because of this reason the very less power is required for the test. The open circuit and the short circuit test gives the very accurate result as compared to the full load test.

Open Circuit Test:

The purpose of the open circuit test is to determine the no-load current and losses of the transformer because of which their no-load parameter are determined. This test is performed on the primary winding of the transformer. The wattmeter, ammeter and the voltage are connected to their primary winding. The nominal rated voltage is supplied to their primary winding with the help of the ac source.

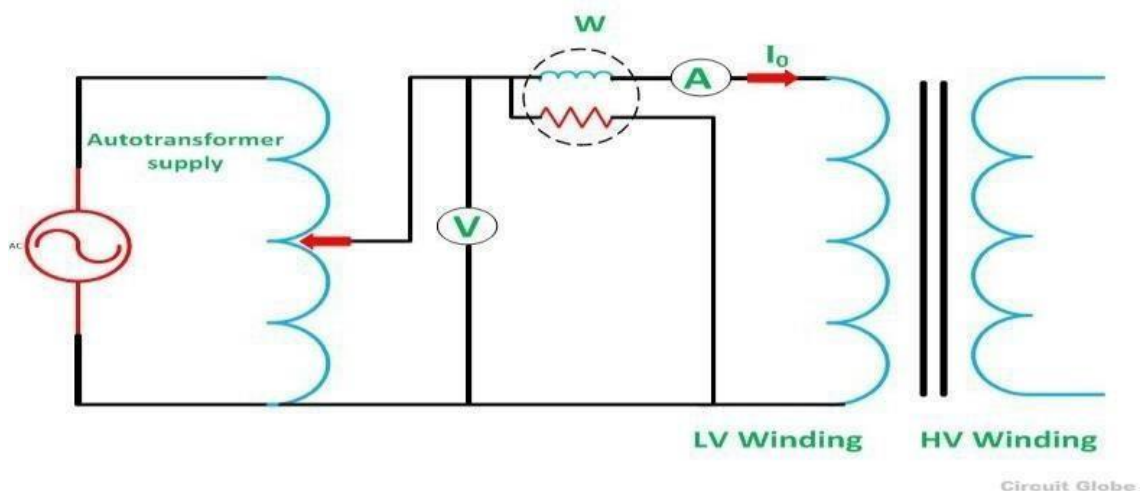

The secondary winding of the transformer is kept open and the voltmeter is connected to their terminal. This voltmeter measures the secondary induced voltage. As the secondary of the transformer is open the no-load current flows through the primary winding.

The value of no-load current is very small as compared to the full rated current. The copper loss occurs only on the primary winding of the transformer because the secondary winding is open. The reading of the wattmeter only represents the core and iron losses. The core loss of the transformer is same for all types of loads.

Calculation of open circuit test:

Let,

W₀ – wattmeter reading

V₁ – voltmeter reading

I₀ – ammeter reading

Then the iron loss of the transformer P_i = W₀ and

$$W_0 = V_1 I_0 \cos \phi_0 \dots\dots\dots(1)$$

The no-load power factor is

$$\cos \phi_0 = \frac{W_0}{V_1 I_0}$$

Working component I_w is

$$I_w = \frac{W_0}{V_1} \dots\dots\dots(2)$$

Putting the value of W₀ from the equation (1) in equation (2) you will get the value of working component as

$$I_w = I_0 \cos \phi_0$$

Magnetizing component is

$$I_m = \sqrt{I_0^2 - I_w^2}$$

No load parameters are given below Equivalent exciting resistance is

$$R_o = \frac{V_1}{I_w}$$

Equivalent exciting reactance is

$$X_o = \frac{V_1}{I_m}$$

The iron losses measured by the open circuit test are used for calculating the efficiency of the transformer.

Short Circuit Test:

The short circuit test is performed for determining the below mention parameter of the transformer.

- It determines the copper loss occur on the full load. The copper loss is used for finding the efficiency of the transformer.

- The equivalent resistance, impedance, and leakage reactance are known by the short circuit test. The short circuit test is performed on the secondary or high voltage winding of the transformer. The measuring instrument like wattmeter, voltmeter and ammeter are connected to the High voltage winding of the transformer. Their primary winding is short circuited by the help of thick strip or ammeter which is connected to their terminal.

The low voltage source is connected across the secondary winding because of which the full load current flows from both the secondary and the primary winding of the transformer. The full load current is measured by the ammeter connected across their secondary winding.

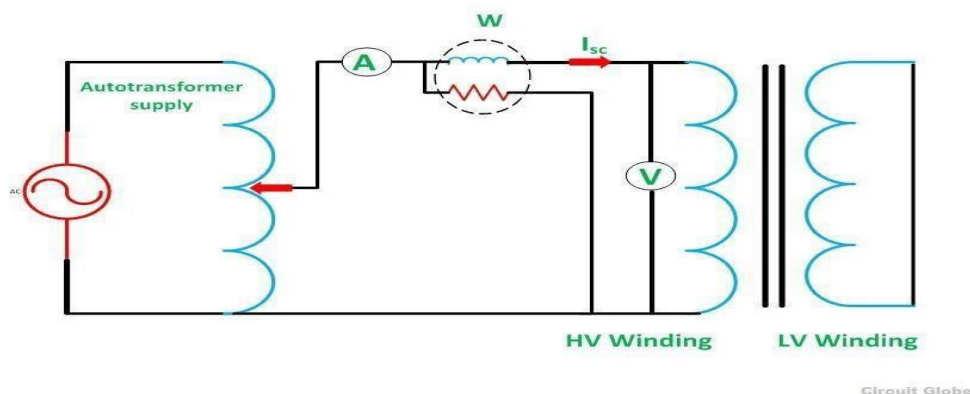

The low voltage source is applied across the secondary winding which is approximately 5 to 10% of the normal rated voltage. The magnitude of the flux is small as compared to the normal flux. The iron loss of the transformer depends on the flux. It is less occur in the short circuit test because of the low value of flux. The reading of the wattmeter only determines the copper loss occur on their windings. The voltmeter measures the voltage applied to their high voltage winding. The secondary current induces in the transformer because of the applied voltage.

Calculation of Short Circuit Test

Let,

W_c – Wattmeter reading

V_{2sc} – voltmeter reading

I_{2sc} – ammeter reading

Then the full load copper loss of the transformer is given by

$$P_c = \left(\frac{I_{2fl}}{I_{2sc}} \right)^2 W_c \quad \text{And} \quad I_{2sc}^2 R_{es} = W_c$$

Equivalent resistance referred to secondary side is

$$R_{es} = \frac{W_c}{I_{2sc}^2}$$

Equivalent impedance referred to the secondary side is given by

$$Z_{es} = \frac{V_{2sc}}{I_{2sc}}$$

The Equivalent reactance referred to the secondary side is given by

$$X_{es} = \sqrt{(Z_{es})^2 - (R_{es})^2}$$

The voltage regulation of the transformer can be determined at any load and power factor after knowing the values of Z_{es} and R_{es} .

In the short circuit test the wattmeter record, the total losses including core loss but the value of core loss are very small as compared to copper loss so, the core loss can be neglected.

ALL DAY EFFICIENCY OF A TRANSFORMER:

Definition: All day efficiency means the power consumed by the transformer throughout the day. It is defined as the ratio of output power to the input power in kWh or Wh of the transformer over 24 hours. Mathematically, it is represented as

$$\text{All day efficiency, } \eta_{\text{all day}} = \frac{\text{output in kWh}}{\text{input in kWh}} \quad (\text{for 24 hours})$$

All day efficiency of the transformer depends on their load cycle. The load cycle of the transformer means the repetitions of load on it for a specific period.

PARALLEL OPERATION OF TRANSFORMERS

Sometimes, it becomes necessary to connect more than one transformer's in parallel, for example, for supplying excess load of the rating of existing transformer. If two or more transformers are connected to a same supply on the primary side and to a same load on the secondary side, then it is called as parallel operation of transformers.

Necessity of Parallel Operation of Transformers:

- **Increased Load:** When load is increased and it exceeds the capacity of existing transformer, another transformer may be connected in parallel with the existing transformer to supply the increased load.
- **Non-availability of large transformer:** If a large transformer is not available which can meet the total requirement of load, two or more small transformers can be connected in parallel to increase the capacity.
- **Increased reliability:** If multiple transformers are running in parallel, and a fault occurs in one transformer, then the other parallel transformers still continue to serve the load. And the faulty transformer can be taken out for the maintenance.
- **Transportation is easier for small transformers:** If installation site is located far away, then transportation of smaller units is easier and may be economical.

Conditions for parallel operation of Transformers:

There are various conditions that must fulfill for the successful operation of transformers as follows.

1. The line voltage ratio of two transformers must be equal.
2. The per unit impedance of each transformer should be equal and they should have same ratio of equivalent leakage reactance to the equal resistance(X/R).
3. The transformers should have same secondary winding polarity.
4. The Transformers should have same phase sequence (Three phase transformer)
5. The transformers should have the zero relative phase replacement between the secondary line voltages. (Three phase transformers)

AUTOTRANSFORMER

A Transformer, in which a part of the winding is common to both the Primary and Secondary circuit, is called an Auto Transformer. In Two Winding Transformer, Primary and Secondary windings are electrically isolated but in Auto Transformer, the two windings are not electrically isolated.

PRINCIPLE OF OPERATION OF AUTOTRANSFORMER:

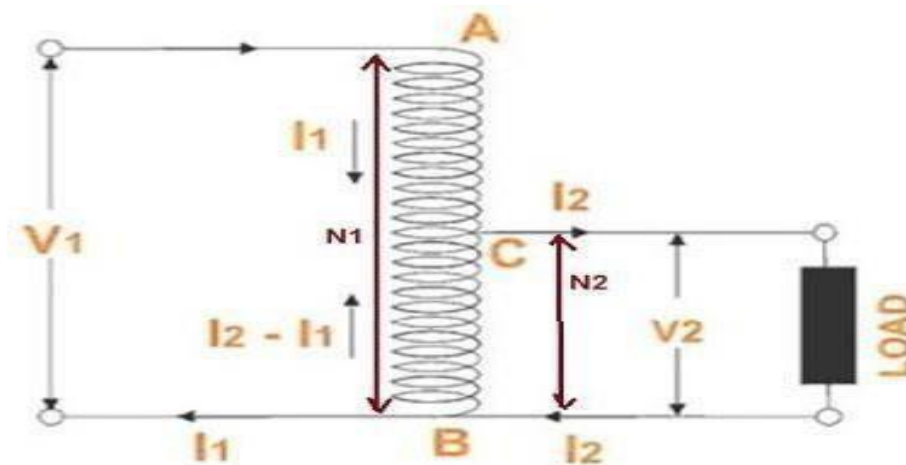

AB is the primary winding and BC is the secondary winding. The primary and secondary windings are electrically and magnetically connected. N_1 and N_2 are the number of turns between winding AB and AC respectively. If a voltage V_1 is applied across AB, an exciting current will start flowing through the full winding. Therefore, voltage per turn in winding AB is V_1/N_1 and hence voltage across CB is $(V_1/N_1)N_2$.

As the load current is I_2 and the current taken from the source is I_1 , neglecting losses

Input Power = Output Power

$$V_1 I_1 \cos \phi_1 = V_2 I_2 \cos \phi_2 \dots \dots \dots (1)$$

Assuming internal impedance drop and losses to be negligible, power factor for primary and secondary will be almost same. $\cos \phi_1 = \cos \phi_2$

Therefore from equation (1),

$$V_1 I_1 = V_2 I_2$$

$$V_2 / V_1 = I_1 / I_2 = N_2 / N_1 = k(\text{say})$$

For Step down Auto Transformer, $k < 1$

For Step up Auto Transformer, $k > 1$

Since the direction of flow of load current is in the opposite to the current flowing in the Primary because of Lenz's Law, hence the current flowing in winding BC = $(I_2 - I_1)$

$$I_{CB} = (I_2 - I_1)$$

Comparison of Auto Transformer with a Two Winding Transformer

Saving in Copper: Volume and hence weight of copper, is proportional to the length and area of cross-section of the conductors. But length of conductor is proportional to the product of the current and number of turns i.e.,

Weight of copper \propto No. of turns x current.

Weight of copper in section AC is $\propto (N_1 \times N_2) I_1$

Weight of copper in section BC is $\propto (I_2 \times I_1) N_2$

Total weight of copper in auto-transformer is proportional to $(N_1 \times N_2) I_1 \times N_2 (I_2 \times I_1)$

If a two-winding transformer were to perform the same duty then

Weight of copper on its primary $\propto N_1 I_1$

Weight of copper on its secondary $\propto N_2 I_2$

\therefore Total weight of copper $\propto N_1 I_1 + \propto N_2 I_2$

Weight of Copper in autotransformer

\propto _____

Weight of Copper in ordinary transformer

$$W_a = (N_1 \square N_2)I_1 \square N_2(I_2 \square I_1)$$

□

$$W_0 = N_1 I_1 \square N_2 I_2$$

$$W_a = N_1 I_1 \square N_2 I_1 \square N_2 I_2 \square N_2 I_1$$

□

$$W_0 = N_1 I_1 \square N_2 I_2$$

$$W_a = N_1 I_1 \square N_2 I_2 \square \square \quad 2N_2 I_1$$

□

$$W_0 = N_1 I_1 \square N_2 I_2 \quad N_1 I_1 \square N_2 I_2$$

N

$$W_a = 1 \square \square \quad 2 N_2 \quad \square 1 \square \square 2K$$

$$W_0 = 1 \square \overline{N_2} I_2 \quad 1 \square K$$

$$N_1 I_1 \quad K$$

$$W_a = 1 \square 2K \square 1 \square K \quad [N_2 \square K; I_2 \square 1] \square \quad \square \quad \square$$

—

$$W_0 = 1 \square 1 \quad N_1 \quad I_1 \quad K$$

Weight of copper in auto transformer,

$$W_a = W_0(1 - K)$$

=weight of cu in ordinary transformer (1-K)

$$\text{Saving in copper} = W_0 \square W_a \square W_0 \square (1 \square K)W_0 \square KW_0$$

$$=K (\text{wt. of cu in ordinary transformer})$$

Advantages of Auto transformer:

- Less costly
- Better regulation
- Less size for same ratings.
- Continuously variable voltage can be obtained by moving sliding contact on secondary.

- Low losses as compared to ordinary two winding transformer of the same rating.

Disadvantages of Auto transformer:

There are various advantages of the auto transformer, but then also one major disadvantage, why auto transformer is not widely used, is that

- The secondary winding is not insulated from the primary winding.
If an auto transformer is used to supply low voltage from a high voltage and there is a break in the secondary winding, the full primary voltage comes across the secondary terminal which is dangerous to the operator and the equipment. So the auto transformer should not be used to for interconnecting high voltage and low voltage system.
 - Used only in the limited places where a slight variation of the output voltage from input voltage is required.
 - The short circuit current is larger than that for two winding Transformer.
-
-

Applications of Auto transformer:

- It is used as a starter to give upto 50 to 60% of full voltage to the stator of a squirrel cage induction motor during starting.
- It is used to give a small boost to a distribution cable, to correct the voltage drop.
- It is also used as a voltage regulator
- Used for giving variable voltage.
- Used in power transmission and distribution system and also in the audio system and railways.
- Used as furnace transformers for getting a desired supply to suit the furnace winding from a 230V supply.
- Used in laboratories etc., for obtaining varying voltages;

- Used in transformer oil testing set.

TAP-CHANGING TRANSFORMERS

The change of voltage is affected by changing the numbers of turns of the transformer provided with taps. For sufficiently close control of voltage, taps are usually provided on the high voltage windings of the transformer. There are two types of tap-changing transformers

1. Off-load tap changing transformer
2. On-load tap changing transformer

Off-load tap-changing transformer:

In this method, the transformer is disconnected from the main supply when the tap setting is to be changed. The tap setting is usually done manually.

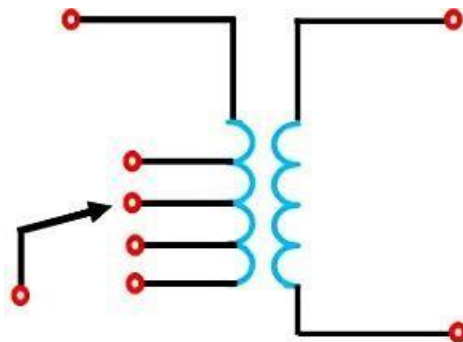

Off-load tap-changing transformer

© Circuit Globe

On-load tap-changing transformer:

In order that the supply may not be interrupted, on-load tap changing transformer is used. Such a transformer is known as a tap-changing under load transformer. While tapping, two essential conditions are to be fulfilled.

- The load circuit should not be broken to avoid arcing and prevent the damage of contacts.
 - No parts of the windings should be short-circuited while adjusting the tap.
-

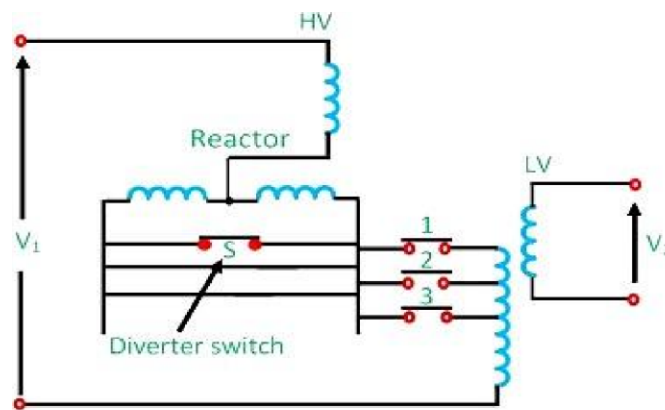

On-load tap changing using a reactor

The tap changing employing a center tapped reactor R show in the figure above. Here S is the diverter switch, and 1, 2, 3 are selector switch. The transformer is in operation with switches 1 and S closed. To change to tap 2, switch S is opened, and 2 is closed. Switch 1 is then opened, and S closed to complete the tap change. The diverter switch operates on load, and no current flows in the selector switches during tap changing. During the tap change, only half of the reactance which limits the current is connected in the circuit.

INSTRUMENT TRANSFORMERS

Transformers used in conjunction with measuring instruments for measurement purposes are called "Instrument Transformers". The instrument used for the measurement of current is called a "Current Transformer" or simply "CT". The transformers used for the measurement of voltage are called "Voltage transformer" or "Potential transformer" or simply "PT".

CURRENT TRANSFORMER

To measure the very high current of the running line without disturbing it, a split core type current transformer is used. At the time of using, with the running line the ammeter is connected to the secondary winding with large number of turns of thin wire and the running line acts as a primary. The emf is induced in the secondary when a flux is produced around the running line and ammeter gives the deflection.

Basically, the current transformers (C.T.) are step up transformers. The primary of the current transformers consists of a few turns or even a single turn of thick wire to carry the current to be measured. Current transformer is connected in series with the main circuit.

The secondary circuit of C.T. should never be kept open, when the primary winding is carrying a current. If the secondary winding of a C.T is kept open, high emf might be induced in the secondary winding which causes excessive heating of core and windings. Also causes accident to human life and damage to C.T.

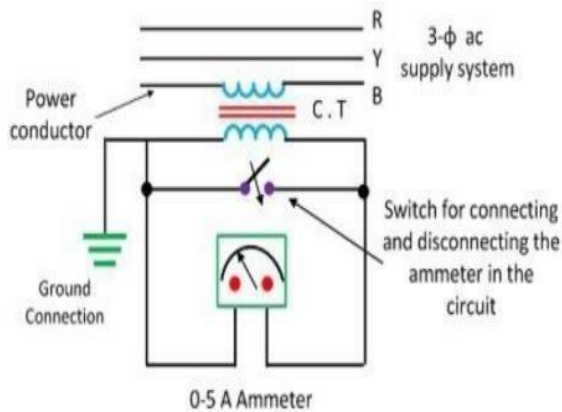

Current Transformer

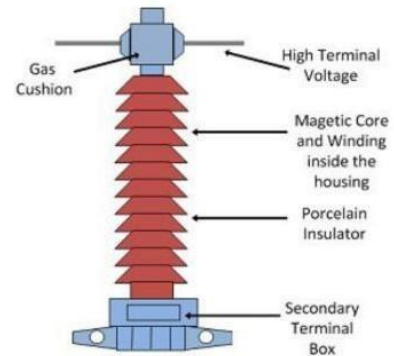

Pictorial view of Current Transformer

POTENTIAL TRANSFORMER (PT):

It is a step down transformer and its principle of operation is same as that of a two-winding transformer. The main point of difference is that the power loading of a P.T. is very small and consequently the exciting current is of the same order as the secondary current while in a power transformer the exciting current is a very small fraction of secondary load current.

The primary winding of potential transformer is connected to the system whose voltage is to be measured. The secondary winding of potential transformer is connected to the voltmeter.

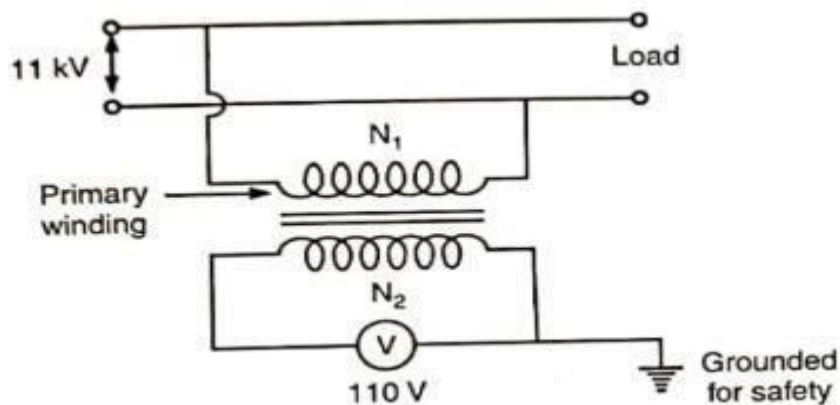

Potential Transformer

Difference between C.T. and P.T.: There are a few differences in the operation of a current transformer and a potential transformer.

- i. The potential transformer may be considered as a parallel' transformer with its secondary nearly under open circuit conditions whereas the current transformer may be thought as a series transformer under virtual short circuit conditions. Thus the secondary of a P.T. can be open-circuited without any damage being caused either to the operator or to the transformer.
- ii. The primary current in a C.T. is independent of the secondary circuit conditions while the primary current in a P.T. certainly depends upon the secondary burden.
- iii. In a potential transformer, full line voltage is impressed upon its terminals whereas a C.T. is connected in series with one line and a small voltage exists across its terminals. However, the C.T. carries the full line current.
- iv. Under normal operation the line voltage is nearly constant and, therefore, the flux density and hence the exciting current of a potential transformer varies only over a restricted range whereas the primary current and excitation of a C.T. vary over wide limits in normal operation.

Transformation Ratio : It is the ratio of the magnitude of the primary phasor to the secondary phasor.

$$\text{Transformation ratio } R = \frac{\text{Primary Phasor}}{\text{secondary phasor}}$$

$$= \frac{\text{Primary Current}}{\text{Secondary Current}} \text{ for a C.T.}$$

$$= \frac{\text{Primary Voltage}}{\text{Secondary Voltage}} \text{ for a P.T}$$

Nominal Ratio = It is the ratio of rated primary current (or voltage) to the rated secondary current (or voltage)

$$\text{Nominal Ratio } K_n = \frac{\text{rated Primary Current}}{\text{rated Secondary Current}} \text{ for a C.T.}$$

$$= \frac{\text{rated Primary Voltage}}{\text{rated Secondary Voltage}} \text{ for a P.T}$$

$$\text{Ratio Error} = \frac{\text{Nominal ratio} - \text{Transformation ratio}}{\text{Transformation ratio}}$$

$$\text{Ratio Error} = \frac{K_n - R}{R}$$

Phase Angle Error :

Ideally the angle between the primary current and secondary current should be 180 degree. But deviation from 180 degree is called phase angle error. This

nd secondary current should be 180 degree. But deviation from 180 degree is called phase angle error.

$$= \frac{180}{\pi} \left[\frac{I_m \cos \delta - I_e \sin \delta}{n I_s} \right]$$

$$= \frac{(\text{secondary induced voltage})^2}{\text{impedance of secondary circuit including impedance of secondary winding}}$$

$$= \frac{(\text{secondary terminal voltage})^2}{\text{impedance of load on secondary winding}}$$

Phase Angle Error

degree

Burden : The product of voltage and current supplied by the secondary to the instrument is called Burden on the secondary or rated 'Burdens' of CTs refer to the maximum load in volt-amperes (VA) which may be applied across the secondary terminals, without the ratio and phase angle errors exceeding the permissible limits. The burden depends upon the number or instruments connected.

Total secondary burden

$$= (\text{secondary current})^2 \times (\text{impedance of secondary circuit including secondary winding})$$

Secondary burden due to load

$$= (\text{secondary current})^2 \times (\text{impedance of load on secondary winding})$$

Uses of Current Transformer (CT):

1. To measure large load currents, such as in transmission lines, with low range ammeters, 2. To operate protective relays.
3. To increase the current range of instruments such as wattmeters, energy meters etc.
4. To provide necessary electrical isolation for instruments from the supply.

Uses of Potential Transformer (P.T):

1. To measure high voltage with low voltage voltmeter potential transformer is used.
2. It is used to operate the pilot lights.
3. To operate relays.
4. To increase the voltage of instruments like wattmeter, energy meter etc.