

LEARNING MATERIAL

**GOVERNMENT POLYTECHNIC BHUBANESWAR,
DEPARTMENT OF MECHANICAL ENGINEERING**

THERMAL ENGINEERING – II

(For Diploma and Polytechnic students)

NAME – HEMANT BARICK

DESIGNATION-SR. Lect.

Mechanical Engineering Department

4TH SEMESTER

CONTENTS

- Chapter – 1..... Vapour Power Cycles 1- 11**
- Chapter – 2..... Gas Power Cycles..... 12-27**
- Chapter – 3..... Fuel & Comsumptions..... 28-38**
- Chapter – 4..... Heat Transfer 39-56**
- Chapter – 5..... Refrigeration Cycles 57-71**

CHAPTER -1

VAPOUR POWER CYCLES

Syllabus:

Steam power plant lay out
Steam power plant cycle
Carnot vapor cycle
Rankine vapor cycle
Modifications to Rankine vapor cycles
Qualities of ideal working fluid for vapor power cycle
Binary vapor cycles

STEAM POWER PLANT CYCLE:

Water is the working fluid here. It undergoes a change of phase in the course of cycle. Energy is released by the continuous burning of the fuel in the combustion chamber of a steam generation plant that includes a boiler and superheater. The working fluid is charged to the boiler via a BFW feed pump. Heat is transferred to the water in the boiler whereupon a high pressure and high temp saturated steam is generated in the boiler. The dry saturated HP steam is converted into a HP superheated steam in the super heater.

The high pressure and high temperature superheated steam is then allowed to expand through the steam turbine. As the steam passes over the blades of the turbine, it sheds its enthalpy which is converted into shaft work of the turbine which then generates power from the turbo alternator coupled to the turbine.

NAME – HEMANT BARICK

DESIGNATION-SR. Lect.

Mechanical Engineering Department

THERMAL ENGINEERING - II

The steam after expansion in the ST is exhausted into a total condenser which is essentially a water steam heat exchanger wherein the exhaust steam is condensed into a condensate only to be recycled to the boiler via the boiler feed pump.

So a simple steam power cycle comprises a boiler + turbine + condenser + BFW pump where water is acting as the working fluid.'

Sometimes a vapour power cycle is referred to as a pressure limited cycle indicating the power plant operates between two pressure limits:

- The higher pressure limit is the boiler pressure
- The lower pressure limit is the condenser pressure.

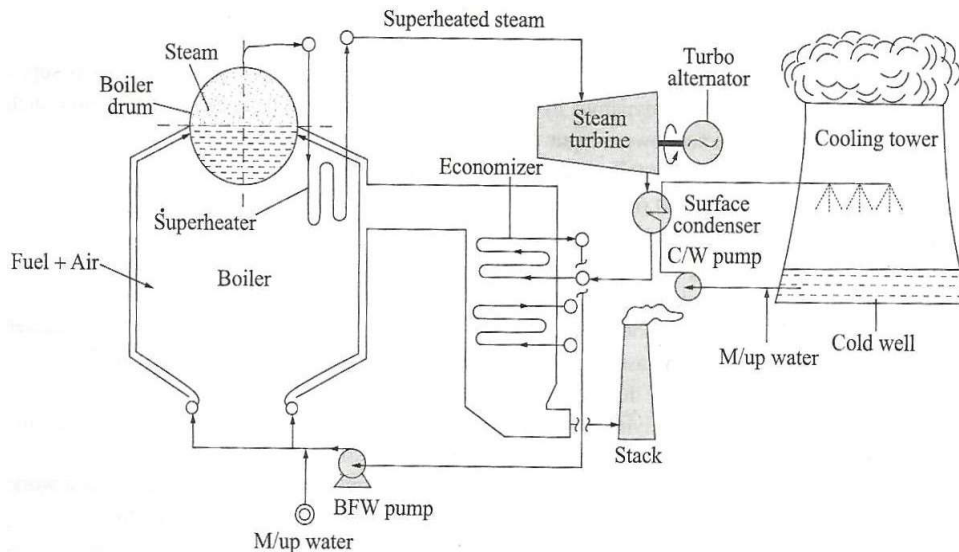

As the case of first approximation, the steam power plant cycle is idealized as a quasi- static process approximating an ideal heat engine cycle:

$$\sum_{cycle} Q_{net} = \sum_{cycle} W_{net}$$

$$\text{Or } Q_1 - Q_2 = W_T - W_P$$

Where Q_1 = the heat input to water in the SGP(BFW preheater + boiler + superheater) in $kJ \cdot kg^{-1}$

Q_2 = the heat rejected from the working fluid (in the surface condenser) $kJ \cdot kg^{-1}$

NAME – HEMANT BARICK

DESIGNATION-SR. Lect.

Mechanical Engineering Department

$W_T = \text{the work output (the shaft work of the steam turbine) } \text{kJ} \cdot \text{kg}^{-1}$

THERMAL ENGINEERING - II

NAME – HEMANT BARICK
DESIGNATION-SR. Lect.
Mechanical Engineering Department

THERMAL ENGINEERING - II

W_p = the mechanical work input (the BFW pump work) $kJ \cdot kg^{-1}$

The efficiency of the ideal vapour power cycle, $\eta_{cycle} = \frac{\Sigma net}{Q_1}$

Thermal efficiency (η) :

Thermal efficiency is an important index of performance of a heat engine or steam power plant cycle. It is obtained from the first law: $\eta = \frac{w}{Q_{input}}$

CARNOTS CYCLE:

An ideal vapour power cycle would follow a Carnot vapour cycle that comprises two iso-thermal and two adiabatic processes. In the vapour cycle, the working substance changes phases. These are attainable by two internally reversible isothermal processes in the form of boiling of the liquid and condensation of the vapour. But, the heat transfer from a high temp. reservoir as well as from the condensing vapour to a low temp. reservoir will remain externally irreversible.

Process 4-1:

Isothermal heat addition to the water. The water is converted into a dry saturated steam

Heat added = Q_{add}

Process 1-2:

Isentropic expansion of the steam in the steam turbine i.e; the steam is expanding adiabatically.

Heat interaction is nil, positive work output = W

Process 2-3:

Isothermal heat rejection. Heat is extracted from the waste steam exhausted by the steam turbine to the condenser,

Heat rejected = Q_{rej}

Process 3-4:

The steam water mixture is pumped to the boiler.

Input work = pump work = W_p

Net work output $W_{net} = W_{output} - W_p$

NAME – HEMANT BARICK

DESIGNATION-SR. Lect.

Mechanical Engineering Department

Therefore, efficiency, $\eta = \frac{W_{net}}{Q_{add}} = \frac{Q_{add} - Q_{rej}}{Q_{add}}$

$$= 1 - \frac{Q_{rej}}{Q_{add}}$$

$$= 1 - \frac{m(h_2 - h_3)}{m(h_1 - h_4)}$$

Also, $\eta = 1 - \frac{T_2}{T_1}$

RANKINE CYCLE:

A Rankine vapour cycle is based on a modified Carnot cycle to overcome its limitations. It consists of four steady flow processes as in figure

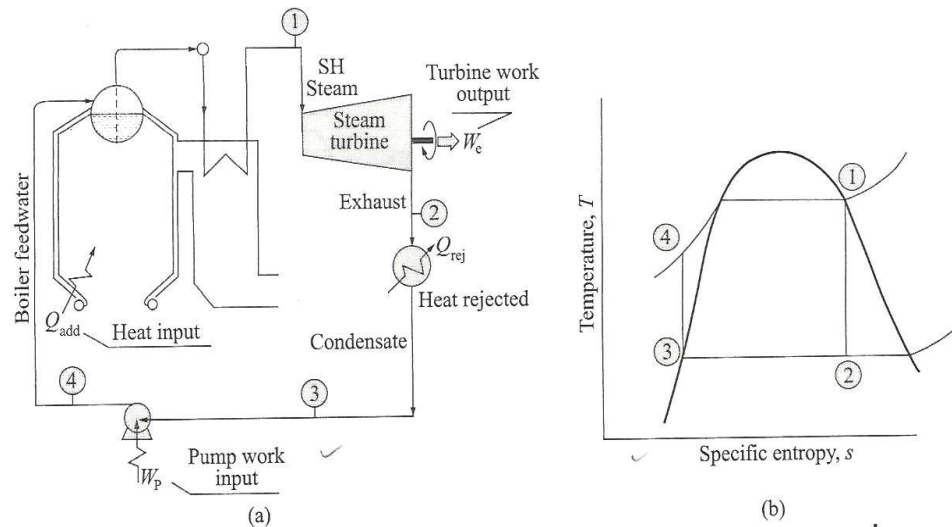

Process 4-1:

Heat is added in the boiler to the BFW, which is a constant pressure process generating a dry, saturated steam at saturation temp. corresponding to the boiler operating pressure,

$$Q_{add} = m(h_1 - h_4)$$

Process 1-2:

The steam is reversibly and adiabatically expanded in the turbine.

So, turbine work input = $W_e = m(h_1 - h_2)$

NAME – HEMANT BARICK

DESIGNATION-SR. Lect.

Mechanical Engineering Department

Process 2-3:

Constant pressure heat rejection in the condenser. The cooling water extracts the latent heat of condensation from the exit steam exhausted to the condenser. the condensation is complete. The entire vapour is converted into a condensate.

$$\text{Therefore heat rejection} = m(h_2 - h_3)$$

Process 3-4:

Pump work. This work must be apportioned from the turbine output.

$$W_p = m(h_4 - h_3)$$

$$\text{Net work output, } W_{net} = W_e - W_p$$

Therefore, efficiency,

$$\begin{aligned} &= \frac{W_{net}}{Q_{add}} \\ &= \frac{W_e - W_p}{Q_{add}} \\ &= \frac{m(h_1 - h_2) - m(h_4 - h_3)}{m(h_1 - h_4)} \end{aligned}$$

RANKINE CYCLE WITH SUPERHEATED STEAM:

If the heating of the working fluid(BFW) is continued beyond the dry saturation point, i.e; well into superheat regime before feeding it to the turbine,i.e; state 1' instead of state 1 , the amount of heat added increase bringing about an incipient increase in the work output

(Δ . *Woutput* = *area* 1 – 1' – 2' – 2) So, superheating begets a higher cycle efficiency.

NAME – HEMANT BARICK

DESIGNATION-SR. Lect.

Mechanical Engineering Department

THERMAL ENGINEERING - II

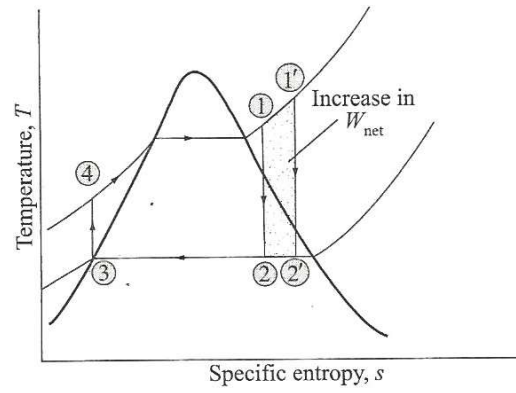

NAME – HEMANT BARICK
DESIGNATION-SR. Lect.
Mechanical Engineering Department

**RANKINE CYCLE WITH SUPERHEATED STEAM:-
EFFECT OF INCREASING PRESSURE WHILE BEING
TEMPERATURE CONSTANT:**

The steam pressure at the SHP exit is increased from p to p' while maintaining a constant superheated steam temperature, i.e; $T_1 = T_1'$.

The operating conditions of the condenser remain unchanged. The work output remains nearly the same, i.e; there is no drastic gain in the work output;

$$\Delta. W_{\text{output}, p} = \text{area } 1 - 2 - 3 - 4 - 1$$

$$\begin{aligned} & \Delta. W_{\text{output}, p'} \\ &= \text{area } 1' - 2' - 3 - 4' - 1' \end{aligned}$$

$$\Delta. W_{\text{output}, p} \approx \Delta. W_{\text{output}, p'}$$

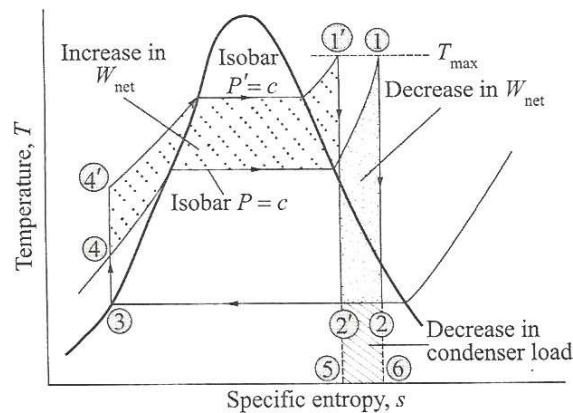

However, the heat rejection area is reduced due to the higher pressure steam utilization (area 2- 2'-5-6).

This increases the efficiency of the cycle.

Efficiency,

$$\eta = \frac{Q_{\text{add}} - Q_{\text{rej}}}{Q_{\text{add}}}$$

$$= 1 - \frac{Q_{\text{rej}}}{Q_{\text{add}}}$$

NAME – HEMANT BARICK

DESIGNATION-SR. Lect.

Mechanical Engineering Department

RANKINE CYCLE WITH SUPERHEATED STEAM: EFFECT OF REDUCING CONSTANT PRESSURE:

If the condenser pressure is reduced, the net work is increased by area $2-2'-3'-4'-4-3-2..$

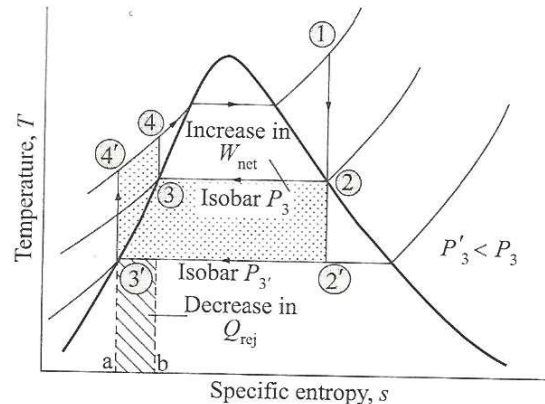

When the operating pressure of the condenser is decreased, the heat added area automatically increases and at the same time Q_{rej} also decreases with the net effect; the cycle efficiency increases..

QUALITIES OF IDEAL WORKING FLUID FOR VAPOUR POWER CYCLES:

The desirable characteristics of the working fluid in a vapour power cycle to ensure the best thermal efficiency of the cycle are :

1. The maximum permissible limits of operating pressure and temp. is set by the metallurgy boiler and super heater tubes, pipes lines, and headers. The working fluid should better have a high critical temp. so that its saturation pressure at the maximum permissible working temp. is relatively low. It should have a large enthalpy of evaporation at that pressure
2. To draw vacuum in the condenser is another costly setup that calls for adequate maintenance as less than the desired vacuum level will tell on the overall cycle efficiency. So it is better that the saturation pressure at the temp. of heat rejection should lie above the atmospheric pressure.
3. The specific heat of liquid should be low so as to boil it out with a relatively little heat transfer. However, low specific heat means a low enthalpy content-not a desirable criterion for a high cycle

NAME – HEMANT BARICK

DESIGNATION-SR. Lect.

Mechanical Engineering Department

efficiency.

NAME – HEMANT BARICK
DESIGNATION-SR. Lect.
Mechanical Engineering Department

4. The saturated vapour line in the T-s diagram should be steep rather than flat. This will safeguard the last stages of the turbine blades from an excessive level of condensation of the working fluid as it expands through the successive stages of the turbine.
5. The freezing point of the working fluid should be below the ambient temp. to avert pipeline chocking due to freezing.
6. Obviously the working fluid should be chemically stable and non-reactive with the materials of construction of the operating system at the maximum working temp
7. The working fluid must be abundantly available to buy economy.
8. It must be non-toxic, non-corrosive, and not excessively viscous.

BINARY VAPOUR POWER CYCLES:

A binary cycle comprises two different cycles working in tandem with two different fluids so that the sink of one becomes the source of the other.

The highest achievable efficiency is that of Carnot's

$$\begin{aligned}\eta_{\text{thermal}} &= \frac{T_1 - T_2}{T_1} \\ &= 1 - \frac{T_2}{T_1}\end{aligned}$$

Which necessitates heat absorption at a constant temp. T_1 and heat rejection at a constant temp. T_2 . Now, the efficiency is fixed by T_1 as T_2 is fixed by the natural sink. This makes it imperative that T_1 should be as large as possible, consistent with the vapour being saturated.

When water is used as the working fluid its critical temp. is 374.15 and the critical pressure is 225 bar. Operating with a critical or supercritical steam entails design complicity and enhances cost, operational and maintenance problems, and controlling difficulties. In order to obviate these difficulties, it would be better to harness some fluid other than steam, which is having more desirable thermodynamic properties than water. The most fitting fluid for this purpose should have a very high critical temp. yet at a low pressure. Mercury, biphenyl oxide and similar other compounds,

NAME – HEMANT BARICK

DESIGNATION-SR. Lect.

Mechanical Engineering Department

THERMAL ENGINEERING - II

~~aluminium bromide, and zinc aluminium chloride are the fluids which~~
possesses the requisite properties in varying degrees. Mercury, among them

NAME – HEMANT BARICK
DESIGNATION-SR. Lect.
Mechanical Engineering Department

THERMAL ENGINEERING - II

,is the best candidate. It has a high critical temp. of 588.4 yet at low critical pressure. Mercury alone can not be used as its saturation temp. at the atmospheric pressure is high(355). Hence ,a binary vapour cycle is used to increase the overall efficiency of the plant.

The most important binary vapour cycle is the mercury steam cycle, which comprises two cycles—mercury cycle and steam cycle.

MERCURY CYCLE:

The mercury cycle is super imposed on the steam cycle. Liquid mercury is circulated through the evaporator tubes in the boiler whereupon the liquid mercury is converted into vapour which is then charged to the mercury turbine where the Hg – vapour expands to generate electric power. The turbine is then exhausted to the mercury condenser boiler where the vapour mercury condenses and then pumped back to the boiler.

STEAM CYCLE:

The heat rejected by the vapour mercury in the mercury condenser boiler is absorbed by the BFW to generate steam at a desired pressure. This steam is then superheated and then charged to the steam turbine to produce an additional power output.

Fuel is burned in the mercury boiler furnace. The liberated heat goes to vaporize the mercury, superheat the steam , and preheat the combustion air and the boiler feedwater.

The heat rejected during the condensation of mercury is transferred to boil water to saturated steam(stage 5-6). The saturated steam is then superheated to state 1 by an external heat source(stage 6-1).

NAME – HEMANT BARICK

DESIGNATION-SR. Lect.

Mechanical Engineering Department

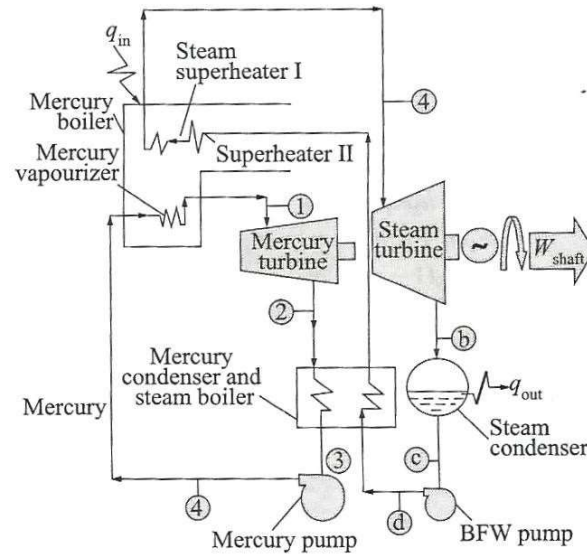
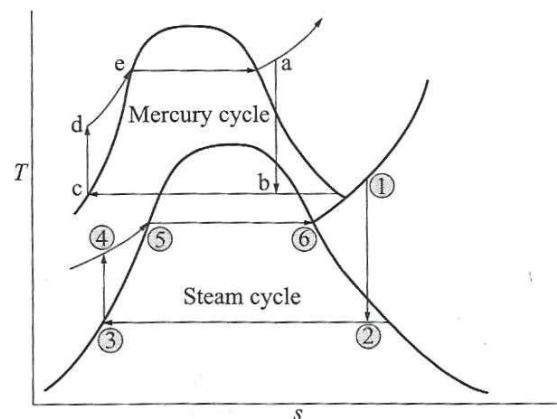

Fig. 9.16(a) Schematic diagram of a mercury-steam binary cycle.



This superheated steam is then allowed to expand in the steam turbine(stage 1-2) and the waste steam is then exhausted to the surface condenser where the condensation is completed(stage 2-3). The condensate is then pumped back (by the BFW group) to the boiler(stage 3-4) . This is then heated in the economizer to the saturated liquid(stage 4-5) and then goes to the mercury condenser steam boiler, where the latent heat is absorbed.

$$\text{Heat supplied} = Q_1 = Q_m = m(h_a - h_d) + (h_1 - h_6) + (h_5 - h_4)$$

$$\text{Heat rejected} = Q_2 = Q_{out} = (h_2 - h_3)$$

NAME – HEMANT BARICK
 DESIGNATION-SR. Lect.
 Mechanical Engineering Department

$$\text{Turbine work} = W_{\text{shaft}} = m(h_a - h_b) + (h_1 - h_2)$$

$$\text{Pump work} = W_{\text{pump}} = m(h_d - h_c) + (h_4 - h_3)$$

The thermal efficiency of the mercury-steam cycle

$$= \eta_{\text{thermal, mer-wat}} = \frac{W_{\text{net}}}{Q_{\text{in}}}$$

$$= \frac{W_{\text{shaft}} - W_{\text{pump}}}{Q_{\text{in}}}$$

$$\text{Steam rate} = \frac{3600}{W_{\text{shaft}} - W_{\text{pump}}} \text{ (kg kwh}^{-1}\text{)}$$

$$\text{Energy balance} = m(h_b - h_c) = h_6 - h_5$$

$$\therefore m = \frac{h_6 - h_5}{h_b - h_c}$$

ADVANTAGES OF MERCURY-STEAM CYCLE:

1. High overall plant efficiency
2. High degree of availability (-85%)
3. Simplicity in operation
4. Reasonable plant maintenance
5. No operational trouble (cf. mercury is toxic)

NAME – HEMANT BARICK

DESIGNATION-SR. Lect.

Mechanical Engineering Department

CHAPTER - 2

GAS POWER CYCLES

SYLLABUS:

Concept of IC Engine
Otto cycle
Diesel cycle
Dual cycle
Comparison of Otto, Diesel and dual cycles
2S and 4S engines and differences thereof

NAME – HEMANT BARICK

DESIGNATION-SR. Lect.

Mechanical Engineering Department

CONCEPT OF IC ENGINE:

Gas engines are designed most frequently as internal combustion engines. These IC engines harness air as the working fluid. The air also serves as the oxidant for the hydrocarbon fluid fired. The combustion of fuel that takes place inside the combustion chamber transforms the chemical energy of the fuel to thermal energy; which is then converted by the engine to the mechanical work output.

The ideal cycle for a gas turbine is the Brayton cycle, whereas the ideal cycle for the IC engines is the Carnot cycle. The IC engine operates on Otto or Diesel cycle, which is the modified version of the Carnot cycle in order to render the cycles realistic.

OTTO CYCLE:

The first successful engine working on this cycle was built by A. Otto. These days, many gas, petrol and many of the oil engines run on this cycle. It is also known as constant volume cycle, as the heat is received and rejected at a constant volume.

The cycle is taken as a standard of comparison for IC engines. For the purpose of comparison with other cycle, the air is assumed to be the working substance.

The engine conceived by Otto has air enclosed in a cylinder, whose walls are perfectly non-conductor of heat. There is also a hot body and cold body and an insulating cap, which are alternately brought in contact with the bottom of the cylinder.

The ideal Otto cycle consists of two constant volume and two reversible adiabatic or isentropic processes as shown in the figure.

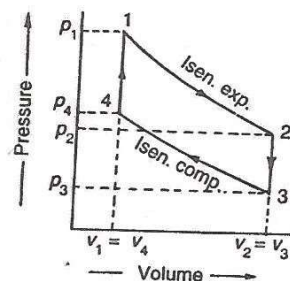

(a) p-v diagram.

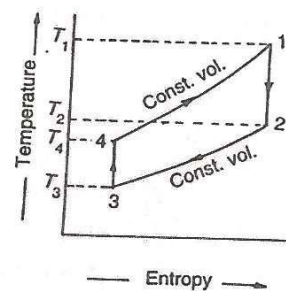

(b) T-S diagram.

NAME – HEMANT BARICK

DESIGNATION-SR. Lect.

Mechanical Engineering Department

THERMAL ENGINEERING - II

Let the engine cylinder contain m kg of air at point 1. At this point, let p_1 , T_1 and v_1 be the pressure, temperature, and volume of the air. Following are the four stages of the ideal cycle:-

1. FIRST STAGE (reversible adiabatic or isentropic expansion):

The air is expanded reversibly and adiabatically from initial temperature T_1 to a temperature T_2 as shown by the curve 1-2. In this process, no heat is absorbed or rejected by the air.

2. SECOND STAGE (constant volume cooling):

The air is cooled at constant volume from temp. T_2 to temp. T_3 as shown by the curve 2-3. We know that heat rejected by the air during this process.

$$Q_{2-3} = m \cdot C_v (T_2 - T_3)$$

3. THIRD STAGE (reversible adiabatic or isentropic compression):-

The air is compressed reversibly and adiabatically from temperature T_3 to a temperature T_4 as shown by the curve 3-4 in fig. In this process, no heat is absorbed or rejected by the air.

4. FOURTH STAGE (constant volume heating):-

The air is now heated at constant volume from temp. T_4 to a temp. T_1 as shown by the curve 4-1. We know heat absorbed by the air during this process.

$$Q_{4-1} = m \cdot C_v (T_1 - T_4)$$

We see that the air has been brought back to its original conditions of pressure, volume and temperature, thus completing the cycle.

We know that Work done = heat absorbed – heat rejected

$$= m C_v (T_1 - T_4) - m C_v (T_2 - T_3)$$

$$\begin{aligned} \text{Ideal efficiency} &= \frac{\text{work done}}{\text{Heat absorbed}} \\ &= \frac{m c_v (T_1 - T_4) - m c_v (T_2 - T_3)}{m c_v (T_1 - T_4)} \end{aligned}$$

NAME – HEMANT BARICK

DESIGNATION-SR. Lect.

Mechanical Engineering Department

THERMAL ENGINEERING - II

$$= 1 - \frac{T_2 - T_3}{T_1 - T_4} = 1 - \frac{T_3 \left(\frac{T_2}{T_3} - 1 \right)}{T_4 \left(\frac{T_1}{T_4} - 1 \right)} \quad \dots (i)$$

We know that for reversible adiabatic or isentropic expansion process 1-2,

$$\frac{T_2}{T_1} = \left(\frac{v_1}{v_2} \right)^{\gamma-1} = \left(\frac{1}{r} \right)^{\gamma-1} \quad \dots (ii)$$

$$r = \text{Expansion ratio} = v_2 / v_1$$

Similarly, for reversible adiabatic or isentropic compression process 3-4,

$$\frac{T_3}{T_4} = \left(\frac{v_4}{v_3} \right)^{\gamma-1} = \left(\frac{1}{r} \right)^{\gamma-1} \quad \dots (iii)$$

$$r = \text{Compression ratio} = v_3 / v_4 = v_2 / v_1$$

From equations (ii) and (iii), we find that

$$\frac{T_2}{T_1} = \frac{T_3}{T_4} = \left(\frac{1}{r} \right)^{\gamma-1} = \frac{1}{(r)^{\gamma-1}} \quad \text{or} \quad \frac{T_1}{T_4} = \frac{T_2}{T_3}$$

Substituting the value of T_1 / T_4 in equation (i),

$$\eta = 1 - \frac{T_3}{T_4} = 1 - \frac{T_2}{T_1} = 1 - \frac{1}{(r)^{\gamma-1}} \quad \dots \left(\because \frac{T_3}{T_4} = \frac{T_2}{T_1} \right) \dots (iv)$$

NAME – HEMANT BARICK

DESIGNATION-SR. Lect.

Mechanical Engineering Department

THERMAL ENGINEERING - II

Example 1. An engine, working on the Otto cycle, has a cylinder diameter of 150 mm and a stroke of 225 mm. The clearance volume is $1.25 \times 10^{-3} \text{ m}^3$. Find the air standard efficiency of this engine. Take $\gamma = 1.4$.

Solution. Given: $d = 150 \text{ mm} = 0.15 \text{ m}$; $l = 225 \text{ mm} = 0.225 \text{ m}$; $v_c = 1.25 \times 10^{-3} \text{ m}^3$;
 $\gamma = 1.4$

We know that swept volume

$$v_s = \frac{\pi}{4} \times d^2 \times l = \frac{\pi}{4} (0.15)^2 (0.225) = 3.976 \times 10^{-3} \text{ m}^3$$

$$\therefore \text{Compression ratio, } r = \frac{v_c + v_s}{v_c} = \frac{1.25 \times 10^{-3} + 3.976 \times 10^{-3}}{1.25 \times 10^{-3}} = 4.18$$

We know that air standard efficiency

$$\begin{aligned} \eta &= 1 - \frac{1}{(r)^{\gamma-1}} = 1 - \frac{1}{(4.18)^{1.4-1}} = 1 - \frac{1}{1.772} \\ &= 1 - 0.564 = 0.436 \text{ or } 43.6\% \text{ Ans.} \end{aligned}$$

Example 2. A certain quantity of air at a pressure of 1 bar and temperature 70° C is compressed reversibly and adiabatically until the pressure is 7 bar in an Otto cycle engine. 460 kJ of heat per kg of air is now added at constant volume. Determine: 1. compression ratio of the engine, 2. temperature at the end of compression, and 3. temperature at the end of heat addition.

Take for air, $c_p = 1 \text{ kJ/kg K}$ and $c_v = 0.707 \text{ kJ/kg K}$.

Solution. Given: $p_3 = 1 \text{ bar}$; $T_3 = 70^\circ \text{ C} = 70 + 273 = 343 \text{ K}$; $p_4 = 7 \text{ bar}$; $Q_{4-1} = 460 \text{ kJ}$;
 $m = 1 \text{ kg}$; $c_p = 1 \text{ kJ/kg K}$; $c_v = 0.707 \text{ kJ/kg K}$

We know that ratio of specific heats,

$$\gamma = c_p / c_v = 1 / 0.707 = 1.41$$

1. Compression ratio of the engine

Let $r = \text{Compression ratio of the engine} = v_3 / v_4$.

We know that $p_3 v_3^\gamma = p_4 v_4^\gamma$

$$\therefore \frac{v_3}{v_4} = \left(\frac{p_4}{p_3} \right)^{\frac{1}{\gamma}} \text{ or } r = \left(\frac{7}{1} \right)^{\frac{1}{1.41}} = (7)^{0.709} = 3.97 \text{ Ans.}$$

NAME – HEMANT BARICK

DESIGNATION-SR. Lect.

Mechanical Engineering Department

THERMAL ENGINEERING - II

2. Temperature at the end of compression

Let T_4 = Temperature at the end of compression.

We know that
$$\frac{T_3}{T_4} = \left(\frac{v_4}{v_3}\right)^{\gamma-1} = \left(\frac{1}{r}\right)^{\gamma-1} = \left(\frac{1}{3.97}\right)^{1.41-1} = (0.252)^{0.41} = 0.568$$

$\therefore T_4 = T_3 / 0.568 = 343 / 0.568 = 604 \text{ K} = 331^\circ \text{C Ans.}$

3. Temperature at the end of heat addition

Let T_1 = Temperature at the end of heat addition.

We know that heat added at constant volume (Q_{4-1}),

$$460 = m c_v (T_1 - T_4) = 1 \times 0.707 (T_1 - 604) \text{ kJ}$$

$\therefore T_1 - 604 = 460 / 0.707 = 651 \text{ or } T_1 = 1255 \text{ K} = 982^\circ \text{C Ans.}$

NAME – HEMANT BARICK

DESIGNATION-SR. Lect.

Mechanical Engineering Department

DIESEL CYCLE:

This cycle was devised by dr. Rudolph diesel in 1893,. With an idea to attain a higher thermal efficiency, with a high compression ratio. This is an important cycle on which all the diesel engine work. It is also called constant pressure cycle as heat is received at a constant pressure.

The engine imagined by diesel has air enclosed in the cylinder , whose walls are perfectly non-conductor of heat, but bottom is a perfect conductor of heat. Again, there is a hot body, cold body and an insulating cap, which are alternately brought in contact with the cylinder.

The ideal diesel cycle consists of two reversible adiabatic or isentropic, a constant pressure and a constant volume processes. These processes are represented on p-v and T-S diagrams as shown in fig.

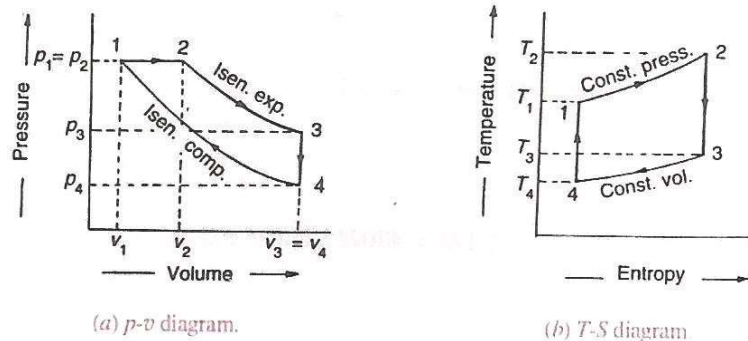

At this point let, P_1 , T_1 and v_1 be the pressure, temperature and volume of the air. Following are four stages of an ideal diesel cycle.

1. FIRST STAGE(constant pressure heating):
The air is heated at constant pressure from initial temp. T_1 to a temp. T_2 represented by the curve 1-2 in figure.
2. SECOND STAGE(reversible adiabatic or isentropic expansion):
The air is expanded reversibly and adiabatically from temperature T_2 to a temperature T_3 as shown by the curve 2-3 in fig.
In this process, no heat absorbed or rejected by the air.
3. THIRD STAGE(constant volume cooling):
The air is now cooled at constant volume from temperature T_3 to T_4 as shown by the curve 3-4 in fig.

NAME – HEMANT BARICK

DESIGNATION-SR. Lect.

Mechanical Engineering Department

THERMAL ENGINEERING - II

Heat rejected by the air, $Q_{3-4} = m.C_v(T_3 - T_4)$

NAME – HEMANT BARICK

DESIGNATION-SR. Lect.

Mechanical Engineering Department

THERMAL ENGINEERING - II

4. FOURTH STAGE(Reversible adiabatic or isentropic compression):-

The air is compressed reversibly and adiabatically from temperature T_4 to a temperature T_1 represented by the curve 4-1 in fig.

In this process, no heat is absorbed or rejected by the air. We see that the air has been brought back to its original conditions of pressure, volume and temperature, thus completing the cycle.

$$\begin{aligned} \text{Work done} &= \text{Heat absorbed} - \text{Heat rejected} \\ &= m c_p (T_2 - T_1) - m c_v (T_3 - T_4) \end{aligned}$$

∴ Air standard efficiency,

$$\begin{aligned} \eta &= \frac{\text{Work done}}{\text{Heat absorbed}} = \frac{m c_p (T_2 - T_1) - m c_v (T_3 - T_4)}{m c_p (T_2 - T_1)} \\ &= 1 - \frac{c_v}{c_p} \left(\frac{T_3 - T_4}{T_2 - T_1} \right) = 1 - \frac{1}{\gamma} \left(\frac{T_3 - T_4}{T_2 - T_1} \right) \quad \dots (i) \end{aligned}$$

Now let compression ratio,

$$r = \frac{v_4}{v_1}$$

Cut-off ratio, $\rho = \frac{v_2}{v_1}$

Expansion ratio, $r_1 = \frac{v_3}{v_2} = \frac{v_4}{v_2} \quad \dots (\because v_3 = v_4)$

$$= \frac{v_4}{v_1} \times \frac{v_1}{v_2} = r \times \frac{1}{\rho} = \frac{r}{\rho}$$

We know for constant pressure heating process 1-2,

$$\frac{v_1}{T_1} = \frac{v_2}{T_2} \quad \dots (\text{Charles's law})$$

$$\therefore T_2 = T_1 \times \frac{v_2}{v_1} = T_1 \times \rho \quad \dots (ii)$$

Similarly, for reversible adiabatic or isentropic expansion process 2-3,

$$\frac{T_3}{T_2} = \left(\frac{v_2}{v_3} \right)^{\gamma-1} = \left(\frac{1}{r_1} \right)^{\gamma-1} = \left(\frac{\rho}{r} \right)^{\gamma-1}$$

$$\therefore T_3 = T_2 \left(\frac{\rho}{r} \right)^{\gamma-1} = T_1 \times \rho \left(\frac{\rho}{r} \right)^{\gamma-1} \quad \dots (iii)$$

for reversible adiabatic or isentropic compression process 4-1,

$$\frac{T_1}{T_4} = \left(\frac{v_4}{v_1} \right)^{\gamma-1} = (r)^{\gamma-1} \quad \text{or} \quad T_1 = T_4 (r)^{\gamma-1} \quad \dots (iv)$$

Substituting the value of T_1 in equations (ii) and (iii),

$$T_2 = T_4 (r)^{\gamma-1} \times \rho \quad \dots (v)$$

$$T_3 = T_4 (r)^{\gamma-1} \times \rho \left(\frac{\rho}{r} \right)^{\gamma-1} = T_4 \rho^\gamma \quad \dots (vi)$$

NAME – HEMANT BARICK

DESIGNATION-SR. Lect.

Mechanical Engineering Department

THERMAL ENGINEERING - II

Now substituting the values of T_1 , T_2 and T_3 in equation (i),

$$\begin{aligned}\eta &= 1 - \frac{1}{\gamma} \left[\frac{(T_4 \rho^\gamma) - T_4}{T_4 (r)^{\gamma-1} \rho - T_4 (r)^{\gamma-1}} \right] \\ &= 1 - \frac{1}{(r)^{\gamma-1}} \left[\frac{\rho^\gamma - 1}{\gamma (\rho - 1)} \right] \quad \dots (vii)\end{aligned}$$

Notes : 1. The efficiency of the ideal Diesel cycle is lower than that of Otto cycle, for the same compression ratio. This is due to the fact that the cut-off ratio (ρ) is always greater than unity and hence the term within the bracket of equation (vii) increases with the increase of cut-off ratio. Thus the negative term increases and the efficiency is reduced.

2. The Diesel cycle efficiency increases with decrease in cut-off ratio and approaches maximum (equal to Otto cycle efficiency) when the term within the bracket is unity.

Example 6.15. In a diesel engine, the compression ratio is 13 : 1 and the fuel is cut-off at 8% of the stroke. Find the air standard efficiency of the engine. Take γ for air as 1.4.

Solution. Given : $r = v_4 / v_1 = 13$; $\gamma = 1.4$

Since the cut-off takes place at 8% of the stroke, therefore volume at cut-off,

$$v_2 = v_1 + 8\% \text{ of stroke volume} = v_1 + 0.08 (v_4 - v_1)$$

Let us assume that the clearance volume (v_1) = 1 m³.

$$\therefore v_4 = 13 \text{ m}^3 \quad \dots (\because v_4 / v_1 = 13)$$

and stroke volume, $v_4 - v_1 = 13 - 1 = 12 \text{ m}^3$

\therefore Volume at cut-off

$$v_2 = v_1 + 0.08 (v_4 - v_1) = 1 + 0.08 \times 12 = 1.96 \text{ m}^3$$

We know that cut-off ratio,

$$\rho = v_2 / v_1 = 1.96 / 1 = 1.96$$

\therefore Air standard efficiency,

$$\begin{aligned}\eta &= 1 - \frac{1}{(r)^{\gamma-1}} \left[\frac{\rho^\gamma - 1}{\gamma (\rho - 1)} \right] = 1 - \frac{1}{(13)^{1.4-1}} \left[\frac{(1.96)^{1.4} - 1}{1.4 (1.96 - 1)} \right] \\ &= 1 - 0.417 = 0.583 \text{ or } 58.3\% \text{ Ans.}\end{aligned}$$

Example 6.16. In an ideal Diesel cycle, the temperatures at the beginning and end of compression are 57° C and 603° C respectively. The temperatures at the beginning and end of expansion are 1950° C and 870° C respectively. Determine the ideal efficiency of the cycle. $\gamma = 1.4$.

If the compression ratio is 14 and the pressure at the beginning of the compression is 1 bar, calculate the maximum pressure in the cycle.

Solution. Given : $T_4 = 57^\circ \text{C} = 57 + 273 = 330 \text{ K}$; $T_1 = 603^\circ \text{C} = 603 + 273 = 876 \text{ K}$; $T_2 = 1950^\circ \text{C} = 1950 + 273 = 2223 \text{ K}$; $T_3 = 870^\circ \text{C} = 870 + 273 = 1143 \text{ K}$; $\gamma = 1.4$; $r = v_4 / v_1 = 14$; $p_4 = 1 \text{ bar}$

Ideal efficiency of the cycle

We know that ideal efficiency of the cycle,

$$\begin{aligned}\eta &= 1 - \frac{1}{\gamma} \left(\frac{T_3 - T_4}{T_2 - T_1} \right) = 1 - \frac{1}{1.4} \left(\frac{1143 - 330}{2223 - 876} \right) \\ &= 1 - 0.431 = 0.569 \text{ or } 56.9\% \text{ Ans.}\end{aligned}$$

NAME – HEMANT BARICK

DESIGNATION-SR. Lect.

Mechanical Engineering Department

THERMAL ENGINEERING - II

Maximum pressure in the cycle

Let p_1 = Maximum pressure in the cycle.

We know that for reversible adiabatic compression,

$$p_1 v_1^\gamma = p_4 v_4^\gamma \text{ or } p_1 = p_4 \left(\frac{v_4}{v_1} \right)^\gamma = 1 (14)^{1.4} = 40.23 \text{ bar Ans.}$$

Example 6.17. An ideal Diesel engine has a diameter 150 mm and stroke 200 mm. The clearance volume is 10 per cent of the swept volume. Determine the compression ratio and the air standard efficiency of the engine if the cut-off takes place at 6 per cent of the stroke.

Solution. Given : $d = 150 \text{ mm} = 0.15 \text{ m}$; $l = 200 \text{ mm} = 0.2 \text{ m}$; $v_c = 10\%$ of $v_s = 0.1 v_s$

Compression ratio

We know that stroke volume,

$$v_s = \frac{\pi}{4} \times d^2 \times l = \frac{\pi}{4} (0.15)^2 \times 0.2 = 3.53 \times 10^{-3} \text{ m}^3$$

$$\therefore v_c = 0.1 v_s = 0.1 \times 3.53 \times 10^{-3} = 0.353 \times 10^{-3} \text{ m}^3$$

We know that compression ratio,

$$\begin{aligned} r &= \frac{\text{Total volume}}{\text{Clearance volume}} = \frac{v_c + v_s}{v_c} = \frac{0.353 \times 10^{-3} + 3.53 \times 10^{-3}}{0.353 \times 10^{-3}} \\ &= 11 \text{ Ans.} \end{aligned}$$

Air standard efficiency

Since the cut-off takes place at 6% of the stroke, therefore volume at cut-off,

$$\begin{aligned} v_2 &= v_1 + 0.06 v_s = v_c + 0.06 v_s \quad \dots (\because v_1 = v_c) \\ &= 0.353 \times 10^{-3} + 0.06 \times 3.53 \times 10^{-3} = 0.565 \times 10^{-3} \text{ m}^3 \end{aligned}$$

$$\therefore \text{Cut-off ratio, } \rho = \frac{v_2}{v_1} = \frac{v_2}{v_c} = \frac{0.565 \times 10^{-3}}{0.353 \times 10^{-3}} = 1.6$$

We know that air standard efficiency,

$$\begin{aligned} \eta &= 1 - \frac{1}{(r)^{\gamma-1}} \left[\frac{\rho^\gamma - 1}{\gamma(\rho - 1)} \right] = 1 - \frac{1}{(11)^{1.4-1}} \left[\frac{(1.6)^{1.4} - 1}{1.4(1.6 - 1)} \right] \\ &= 1 - \frac{1}{2.61} \times 1.11 = 1 - 0.4246 = 0.5753 \text{ or } 57.53\% \text{ Ans.} \end{aligned}$$

NAME – HEMANT BARICK

DESIGNATION-SR. Lect.

Mechanical Engineering Department

THERMAL ENGINEERING - II

DUAL COMBUSTION CYCLE:-

This cycle is a combustion of otto and diesel cycles. It is sometimes called semi-diesel cycle, because semi-diesel engines work on this cycle. In this cycle, heat is absorbed partly at a constant volume and partly at a constant pressure.

The ideal dual combustion cycle consists of two reversible adiabatic or isentropic, two constant volume and a constant pressure processes. These processes are represented on p-v and T-S diagram as shown in fig.

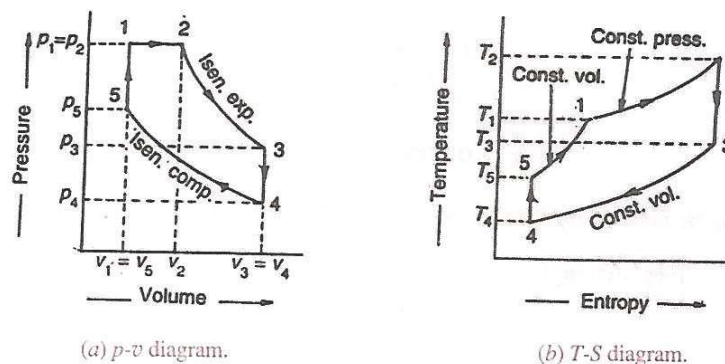

Let the engine cylinder contain m kg of air at point 1. At this point let, P_1, T_1 and v_1 be the pressure, temperature and volume of the air. Following are the five stages of an ideal dual combustion cycle.

- FIRST STAGE(constant pressure heating):-**
The air is heated at constant pressure from initial temperature T_1 to a temperature T_2 represented by the curve 1-2 in fig.
Heat absorbed by the air, $Q_{1-2} = m.C_p (T_2 - T_1)$
- SECOND STAGE(reversible adiabatic or isentropic expansion):-**
The air is expanded reversibly and adiabatically from temp. T_2 to temp. T_3 as shown by the curve 2-3 in fig .
In this process, no heat is absorbed or rejected by the air.
- THIRD STAGE(Constant volume cooling):-**
The air is now cooled at constant volume from temperature T_3 to the temperature T_4 as shown by the curve 3-4 in fig.
Heat rejected by the air, $Q_{3-4} = m.C_v (T_3 - T_4)$
- FOURTH STAGE(Reversible adiabatic or isentropic compression):-**
The air is compressed reversibly and adiabatically from temperature T_4 to a temperature T_5 as shown by the curve 4-5 in fig.
In this process, no heat is absorbed or rejected by the air.

NAME – HEMANT BARICK

DESIGNATION-SR. Lect.

Mechanical Engineering Department

THERMAL ENGINEERING - II

5. FIFTH STAGE(constant volume heating):-

NAME – HEMANT BARICK
DESIGNATION-SR. Lect.
Mechanical Engineering Department

THERMAL ENGINEERING - II

The air is finally heated at constant volume from temperature T_5 to the temperature T_1 as shown by the curve 5-1 in fig.

Heat absorbed by the air, $Q_{5-1} = m.C_v (T_1 - T_5)$. We see that the air has been brought back to its original conditions of pressure, volume, and temperature, thus completing the cycle. We know = heat absorbed – heat rejected = $m.C_p (T_2 - T_1) + m.C_v (T_1 - T_5) - m.C_v (T_3 - T_4)$

COMPARISON OF OTTO, DIESEL AND DUAL CYCLES:

The important variable factors which are used as the basis for comparison of the cycles are compression ratio, peak pressure, heat addition, heat rejection and the net work. In order to compare the performance of the Otto, Diesel and Dual combustion cycles some of the variable factors must be fixed.

SAME COMPRESSION RATIO AND HEAT ADDITION:

The Otto cycle 1 - 2 - 3 - 4 - 1, the Diesel cycle 1 - 2 - 3' - 4' - 1 and the Dual cycle 1 - 2'' - 3'' - 4'' - 1 are shown in figure for the same compression ratio and heat input

For the T-s diagram, it can be seen that Area 5236 = Area 5236 = area 52236 as this area represents the heat input which is the same for all cycles.

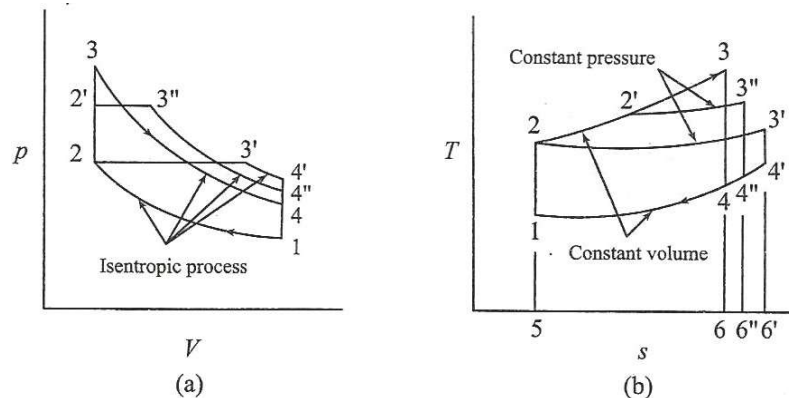

All the cycles start from the same initial state point 1 and the air is compressed from state 1 to 2 as the compression ratio is same. It is seen from the T-s diagram for the same heat input, the heat rejection in Otto cycle (area 5146) is minimum and heat rejection in Diesel Cycle (5146) is maximum. Consequently Otto cycle has the highest work output and efficiency. Diesel cycle has the least efficiency and Dual cycle having the efficiency between the two. For same compression ratio and heat addition,

NAME – HEMANT BARICK
 DESIGNATION-SR. Lect.
 Mechanical Engineering Department

THERMAL ENGINEERING - II

One more observation can be made that is Otto cycle allows the working medium to expand more where as Diesel cycle is least in this respect the reason is heat is added before expansion in the case of Otto cycle and the last portion of heat supplied to the fluid has relatively short expansion in case of the diesel cycle.

SAME COMPRESSION RATIO AND HEAT REJECTION

The p-V and T-s diagrams are in figure

$$\text{Now } \eta_{\text{Otto}} = 1 - \frac{Q_R}{Q_s}$$

Where Q_s is the heat supplied in the Otto cycle and is equal to the area under the curve 23 on the T-s diagram. The efficiency of the diesel cycle is given by

$$\eta_{\text{Diesel}} = 1 - \frac{Q_R}{Q'_s}$$

where Q'_s is heat supplied in the diesel cycle and is equal to area under the curve 23' on the Ts diagram

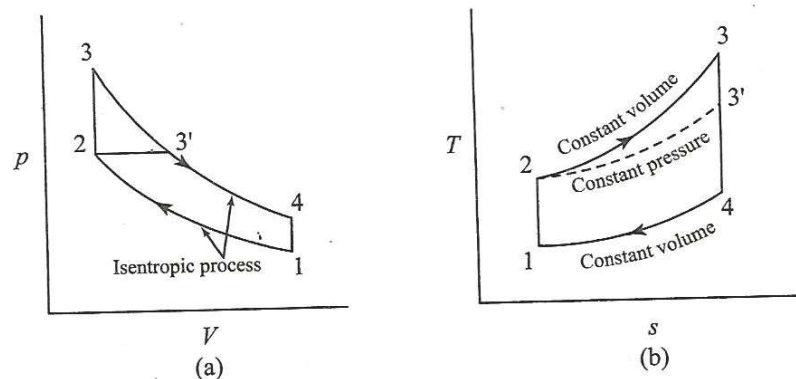

From the T-s diagram as in figure it is clear that $Q_s > Q'_s$ i.e., heat supplied in the Otto cycle is more than that of the diesel cycle. Hence, it is evident that, the efficiency of the Otto cycle is greater than the efficiency of the Diesel cycle for a given compression ratio and heat rejection. Also, for the same compression ratio and heat rejection

$$\eta_{\text{Otto}} > \eta_{\text{Dual}} > \eta_{\text{Diesel}}$$

NAME – HEMANT BARICK

DESIGNATION-SR. Lect.

Mechanical Engineering Department

THERMAL ENGINEERING - II

SAME PEAK PRESSURE, PEAK TEMPERATURE, AND HEAT REJECTION:

The above figure show the Otto cycle 1234 and diesel cycle 1234 on p-V and T-s co-ordinates, where the peak pressure and temperature and the amount of heaty rejected are the same.

The efficiency of the Otto cycle 1234 is given by

$$\eta_{\text{Otto}} = 1 - \frac{Q_R}{Q_s}$$

where Q_s is the area under the curve 2w3 in figure

The efficiency of the diesel cycle, 1234 is

Where Q_s is the area under the curve 23

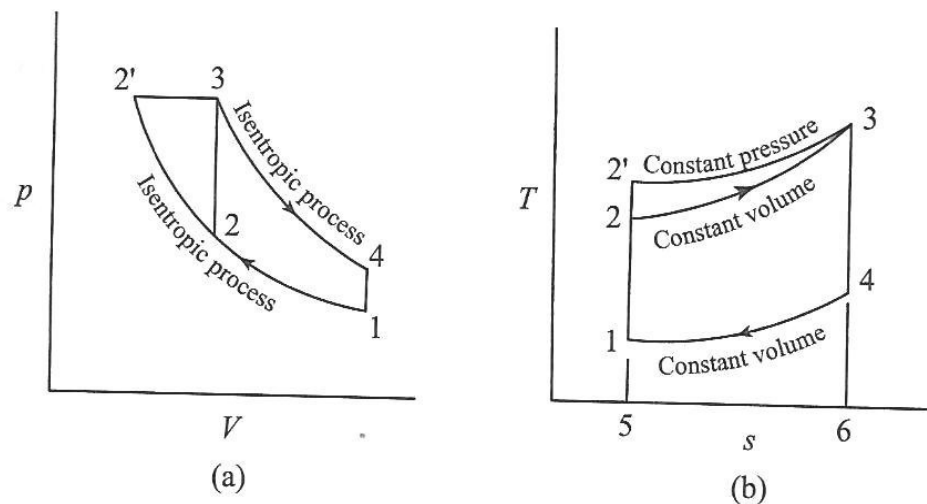

It is evident from figure that Therefore, the diesel cycle efficiency is greater than the Otto cycle efficiency when both engines are built to with stand thesame thermal and mechanical stresses. Also, for the same peak pressure, peak temperature and heat rejection,

NAME – HEMANT BARICK
 DESIGNATION-SR. Lect.
 Mechanical Engineering Department

THERMAL ENGINEERING - II

SAME MAXIMUM PRESSURE AND HEAT INPUT

For same maximum pressure and same heat input the Otto cycle and diesel cycle are shown on p-V and T-s diagrams in the figure

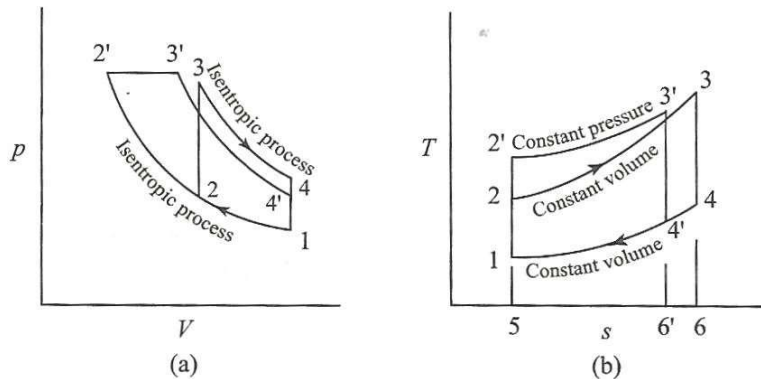

It is evident from the figure that the heat rejection for Otto cycle is more than the heat rejected in diesel cycle. Hence Diesel cycle is more efficient than Otto cycle for the condition of same maximum pressure and heat input. One can make a note that with these conditions the Diesel cycle has higher compression ratio than that of Otto cycle. One should also note that the cycle which is having higher efficiency allows maximum expansion. The dual cycle efficiency will be between these two. Hence, for the same maximum pressure and heat input,

SAME MAXIMUM PRESSURE AND WORK OUTPUT

The efficiency, can be written as

$$\eta = \frac{\text{Work done}}{\text{Heat Supplied}}$$

$$= \frac{\text{Work done}}{\text{Work done} + \text{Heat rejected}}$$

Refer to T-s diagram in the figure. For same work output the area 1234 (work output) and area 123'4' (work output of Diesel Cycle) are same. To achieve this, the entropy at 3 should be greater than entropy at 3'. It is clear that the heat rejection for Otto cycle is more than that of Diesel cycle. Hence, for these conditions the Diesel cycle is more efficient than the Otto cycle. The efficiency of

NAME – HEMANT BARICK

DESIGNATION-SR. Lect.

Mechanical Engineering Department

THERMAL ENGINEERING - II

Dual cycle lies between the two cycles. Hence, for the same maximum pressure and work out put ,

ADVANTAGES AND DISADVANTAGES OF TWO STROKE OVER FOUR STROKECYCLE ENGINES:

1. A two stroke cycle engine gives twice the number of power strokes than the four stroke cycle engines at the same engine speed. Theoretically, a two stroke cycle engine should develop twice the power as that of a four stroke cycle engine. Two stroke cycle engine develops 1.7 to 1.8 times the power developed by four stroke cycle engines of the same dimension and speed. This is due to the lower compression ratio and effective stroke being less than the theoretical stroke.
2. For the same power developed , a two stroke cycle engine is lighter , less bulky, and occupies less floor area. Thus it makes , a two stroke cycle engine suitable for marine engines and other lighting vehicles.
3. As the no. of working strokes in a two stroke cycle engines are twice than the four stroke cycle engines., so the turning moment of a two stroke cycle engine is more uniform. Thus,it makes a two stroke cycle engine to have a lighter fly wheel and foundations. This also leads to a higher mechanical efficiency of a two stroke cycle engine.
4. The initial cost of a two stroke cycle engine is considerably less than a four stroke cycle engine
5. The mechanism of two stroke engine is much simpler than four stroke engine.
6. The two stroke cycle engines are much easier to start.

DISADVANTAGES:

1. Thermal efficiency of a two stroke engine is less than that a four stroke engine because a two stroke engine has less compression ratio than that of a four stroke engine.
2. Overall efficiency of a two stroke engine is also less than that of a four stroke

NAME – HEMANT BARICK

DESIGNATION-SR. Lect.

Mechanical Engineering Department

THERMAL ENGINEERING - II

engine because in a two stroke cycle, inlet and exhaust ports remain

NAME – HEMANT BARICK

DESIGNATION-SR. Lect.

Mechanical Engineering Department

THERMAL ENGINEERING - II

open simultaneously for some time. In spite of careful design, a small quantity of charge is lost from the engine cylinder.

3. In case of two stroke engine, the number of power strokes are twice as those of a four stroke cycle engine. Thus the capacity of cooling system must be higher. Beyond a certain limit, the cooling capacity offers a considerable difficulty. Moreover, there is a greater wear and tear in a two stroke engine.
4. The consumption of lubricating oil is large in a two stroke cycle engine because of high operating temperature.

The exhaust gases in a two stroke cycle engine create noise, because of short time available for their exhaust

NAME – HEMANT BARICK

DESIGNATION-SR. Lect.

Mechanical Engineering Department

CHAPTER – 3

Fuels and Combustion

Syllabus:

Hydrocarbon fuels

Combustion reactions (Explanation only), concept of stoichiometric combustion, complete combustion and incomplete combustion

Enthalpy of formation, enthalpy of reaction

Heating values for fuels

Quality of IC Engine fuels: Octane Number and Cetane number

3.1 Hydrocarbon fuels

The carbon and hydrogen combine in different proportions and molecular structures to form a variety of hydrocarbon. The carbon to hydrogen ratio which is one of the important parameters and their nature of bonding determine the energy characteristics of the hydrocarbon fuels. Depending upon the number of carbon and hydrogen atoms the petroleum products are classified into different groups.

The differences in physical and chemical properties between the different types of hydrocarbon depend on their chemical composition and affect mainly the combustion processes and hence, the properties of fuel and air required in the engine. The basic families of hydrocarbons, their general formulae and their

NAME – HEMANT BARICK

DESIGNATION-SR. Lect.

Mechanical Engineering Department

THERMAL ENGINEERING - II

molecular arrangement are shown in Tabel 6.1.

NAME – HEMANT BARICK

DESIGNATION-SR. Lect.

Mechanical Engineering Department

THERMAL ENGINEERING - II

Table 6.1 Basic Families of Hydrocarbons

Family of hydrocarbons	General formula	Molecular structure	Saturated/Unsaturated	Stability
Paraffin	C_nH_{2n+2}	Chain	Saturated	Stable
Olefin	C_nH_{2n}	Chain	Unsaturated	Unstable
Naphthene	C_nH_{2n}	Ring	Saturated	Stable
Aromatic	C_nH_{2n-6}	Ring	Highly unsaturated	Most unstable

Paraffin Series

The normal paraffin hydrocarbons are of straight chain molecular structure. They are represented by a general chemical formula, C_nH_{2n+2} . The molecular structures of the first few members of the paraffin family of hydrocarbons are shown below.

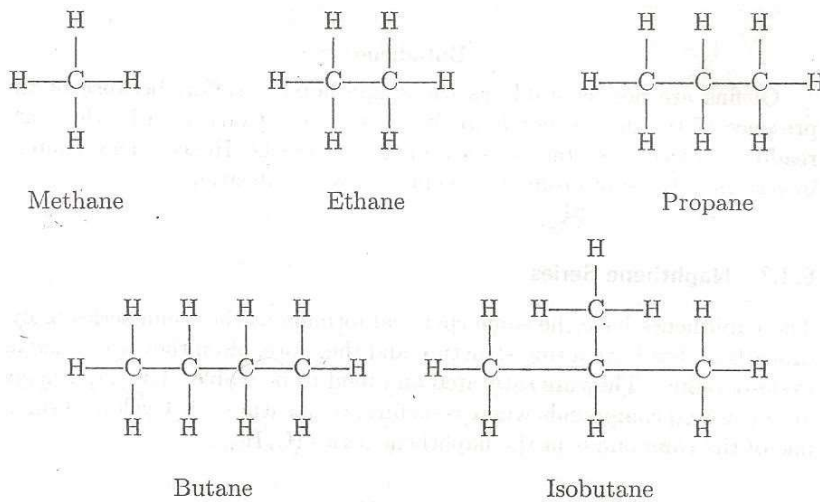

In these hydrocarbons the valency of all the carbon atoms is fully utilized by single bonds with hydrogen atoms. Therefore, the paraffin hydrocarbons are saturated compounds and are characteristically very stable.

A variation of the paraffin family consists of an open chain structure with an attached branch and is usually termed a branched chain paraffin. The hydrocarbons which have the same chemical formulae but different structural formulae are known as isomers.

Isobutane shown above has the same general chemical formula and molecular weight as butane but a different molecular structure and physical characteristics. It is called an isomer of butane and is known as isobutane. Isoparaffins are also stable compounds.

NAME – HEMANT BARICK

DESIGNATION-SR. Lect.

Mechanical Engineering Department

olefin series

Olefin are also straight chain compounds similar to paraffins but are unsaturated because they contain one or more double bonds between carbon atoms. Their chemical formula is C_nH_{2n} . Mono-olefins have one double bond whereas diolefin have two in their structure.

Olefins are not as stable as the single bond paraffins because of the presence of the double bonds in their structure. Consequently, these are readily oxidized in storage to form gummy deposits. Hence, olefin content in certain petroleum products is kept low by specification.

Naphthene series

The naphthenes have the same chemical formula as the olefin series of hydrocarbons but have a ring structure and therefore, often they are called as cycloparaffins. They are saturated and tend to be stable. The naphthenes are saturated compounds whereas olefins are unsaturated. Cyclopentane is one of the naphthene series(C_nH_{2n}).

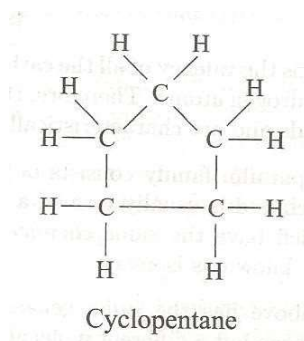

Aromatic compounds are ring structured having a benzene molecule as their central structure and have a general chemical formula C_nH_{2n-6} . Though the presence of double bonds indicate that they are unsaturated, peculiar nature of these double bonds causes them to be more stable than the other unsaturated compounds. Various aromatic compounds are formed by replacing one or more of the hydrogen atoms of the benzene molecules with an organic radical such as paraffins, naphthenes and olefins. By adding a methyl group (CH_3), benzene is converted to toluene($C_6H_5CH_3$), the base for the preparation of Trinitrotoluene (TNT) which is a highly explosive compound.

NAME – HEMANT BARICK

DESIGNATION-SR. Lect.

Mechanical Engineering Department

THERMAL ENGINEERING - II

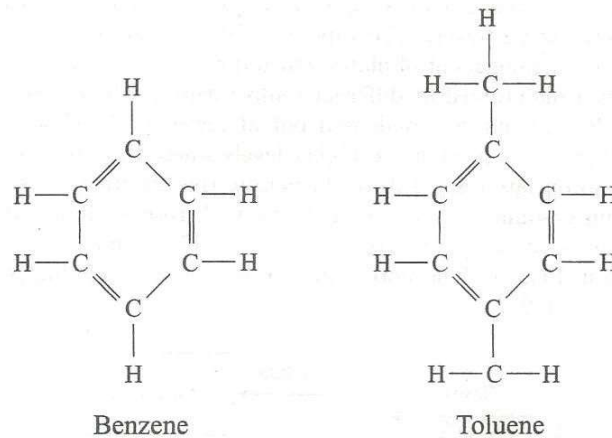

The above families of hydrocarbons some general characteristics due to their molecular structure which are summarized below

- I. Normal paraffins exhibit the poorest antiknock quality when used in an SI engine. But the antiknock quality improves with the increasing number of carbon atoms and the compactness of the molecular structure. The aromatics offer the best resistance to knocking in SI Engines.
- II. For CI engines, the order is reversed i.e., the normal paraffins are the best fuels and aromatics are the least desirable.
- III. As the number of atoms in the molecular structure increases, the boiling temperature increases. Thus fuels with fewer atoms in the molecule tend to be more volatile.
- IV. The heating value generally increases as the proportion of hydrogen atoms to carbon atoms in the molecule increases due to the higher heating value of hydrogen than carbon. Thus, paraffins have the highest value and the aromatics the least.

NAME – HEMANT BARICK

DESIGNATION-SR. Lect.

Mechanical Engineering Department

Combustion reactions

The important combustion reactions are

1. $\text{H}_2 + \frac{1}{2}\text{O}_2 \rightarrow \text{H}_2\text{O (vap)} + 242,050 \text{ kJ kmol}^{-1} \text{ of H}_2$
2. $\text{H}_2 + \frac{1}{2}\text{O}_2 \rightarrow \text{H}_2\text{O (liq)} + 286,223 \text{ kJ kmol}^{-1} \text{ of H}_2$
3. $\text{C} + \frac{1}{2}\text{O}_2 \rightarrow \text{CO}_2 + 123,223 \text{ kJ kmol}^{-1} \text{ of C}$
4. $\text{CO} + \frac{1}{2}\text{O}_2 \rightarrow \text{CO}_2 + 285,637 \text{ kJ kmol}^{-1} \text{ of CO}$
5. $\text{C} + \text{O}_2 \rightarrow \text{CO}_2 + 408,860 \text{ kJ kmol}^{-1} \text{ of C}$
6. $\text{CO}_2 + \text{C} \rightarrow 2\text{CO} - 162,413 \text{ kJ kmol}^{-1} \text{ of C}$
7. $\text{C} + \text{H}_2\text{O} \rightarrow \text{CO} + \text{H}_2 - 118,827 \text{ kJ kmol}^{-1} \text{ of C}$
8. $\text{CH}_4 + 2\text{O}_2 \rightarrow \text{CO}_2 + 2\text{H}_2\text{O} + 805,579 \text{ kJ kmol}^{-1} \text{ of CH}_4$
9. $\text{C}_2\text{H}_2 + 2\frac{1}{2}\text{O}_2 \rightarrow 2\text{CO}_2 + \text{H}_2\text{O} + 1,308,019 \text{ kJ kmol}^{-1} \text{ of C}_2\text{H}_2$
10. $\text{C}_2\text{H}_4 + 3\text{O}_2 \rightarrow 2\text{CO}_2 + 2\text{H}_2\text{O} + 1,447,864 \text{ kJ kmol}^{-1} \text{ of C}_2\text{H}_4$
11. $\text{H}_2\text{S} + 1\frac{1}{2}\text{O}_2 \rightarrow \text{H}_2\text{O} + \text{SO}_2 + 522.747 \text{ kJ kmol}^{-1} \text{ of H}_2\text{S}$
12. $\text{S} + \text{O}_2 \rightarrow \text{SO}_2 + 292,252 \text{ kJ kmol}^{-1} \text{ of S}$

Stoichiometric of combustion:

Stoichiometric of combustion takes place in a Stoichiometric mixture of a fuel and oxygen. A Stoichiometric mixture of a fuel and oxygen contains the precise amount of oxygen to completely burn out all the combustible elements present in the fuel. This implies conversion of all C content to CO₂ and all H content to H₂O. There is neither an excess nor deficiency of oxygen present in the reaction of mixture. And, as a result, there is no free oxygen in the reaction products, while all the combustibles in the fuel are completely oxidized. For instance, the Stoichiometric of combustion of n-butane is

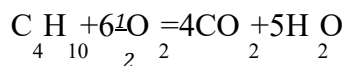

NAME – HEMANT BARICK

DESIGNATION-SR. Lect.

Mechanical Engineering Department

THERMAL ENGINEERING - II

The equation is balanced w.r.t all elements and presents the precise amount of oxygen in the reactants just sufficient to ensure a complete burn out of the fuel.

Complete combustion:

Complete combustion means complete conversion of all combustible elements of a fuel into its stable oxides and as such the enter carbon of the fuel now exists CO₂ and hydrogen as H₂O in the products of combustion .

All practical combustion processes use air as a source of oxygen, the oxidizer of fuel. with 1 kmol of oxygen ,there are 79/21 kmol of nitrogen. hence,

1 .The combustion equation of hydrogen

$2\text{H}_2 + \text{O}_2 \rightarrow 2\text{H}_2\text{O}$ becomes

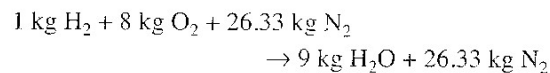
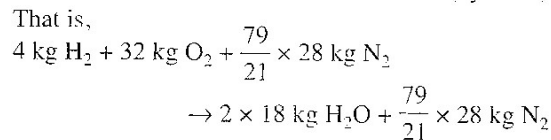
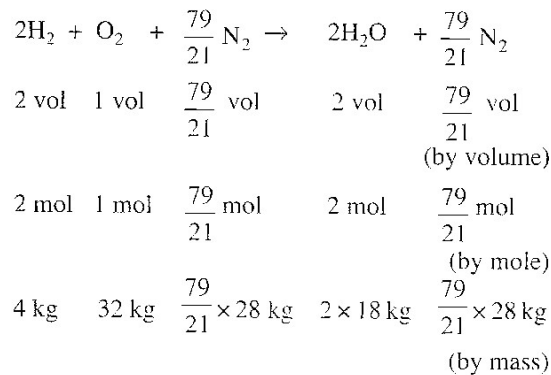

2. The complete combustion equation of carbon

$(\text{C} + \text{O}_2 \rightarrow \text{CO}_2)$ becomes

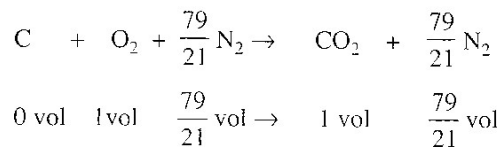

NAME – HEMANT BARICK

DESIGNATION-SR. Lect.

Mechanical Engineering Department

$$\begin{array}{l}
 1 \text{ mol } \quad 1 \text{ mol} \quad \frac{79}{21} \text{ mol} \rightarrow 1 \text{ mol} \quad \frac{79}{21} \text{ mol} \\
 \hspace{15em} \text{(by mole)} \\
 12 \text{ kg } \quad 32 \text{ kg} \quad \frac{79}{21} \times 28 \text{ kg} \quad 44 \text{ kg} \quad \frac{79}{21} \times 28 \text{ kg} \\
 \hspace{15em} \text{(by mass)}
 \end{array}$$

That is,

$$\begin{array}{l}
 12 \text{ kg C} + 32 \text{ kg O}_2 + \frac{79}{21} \times 28 \text{ kg N}_2 \\
 \hspace{10em} \rightarrow 44 \text{ kg CO}_2 + \frac{79}{21} \times 28 \text{ kg N}_2 \\
 1 \text{ kg C} + 2.666 \text{ kg O}_2 + 8.777 \text{ kg N}_2 \\
 \hspace{10em} \rightarrow 3.666 \text{ kg CO}_2 + 8.777 \text{ kg N}_2
 \end{array}$$

Incomplete combustion:

An Incomplete combustion refers to the condition when some unburnt fuel remains in the products. This may occur either due to an insufficient supply of oxygen to combust the fuel elements completely or due to inadequate fuel-air mixing, leading to an inadequate exposure of fuel particles to oxygen during the period of combustion.

The Incomplete combustion leads to C, CO, H₂, or OH in the product stream. If oxygen deficiency leads to an incomplete combustion of a fuel, then the hydrogen in the fuel will preferentially get oxidized to H₂O than carbon to CO.

Enthalpy of formation:

Combustion of hydrocarbon fuels leads to the formation of two major components: H₂O and CO₂

1. Formation of water vapour

Consider a combustion chamber to which are introduced two separate streams—1 kmol of H₂O and 1/2 kmol of O₂—both at 298 K/1 atm. They are mixed and burned. The product, H₂O(liq), also leaves the combustion at 298 K/1 atm

Before combustion

Enthalpy of elemental H₂ and O₂ at 298 K/1 atm is zero

i.e. the enthalpy of the mixture of hydrogen and oxygen prior to the combustion process is zero

NAME – HEMANT BARICK

DESIGNATION-SR. Lect.

Mechanical Engineering Department

THERMAL ENGINEERING - II

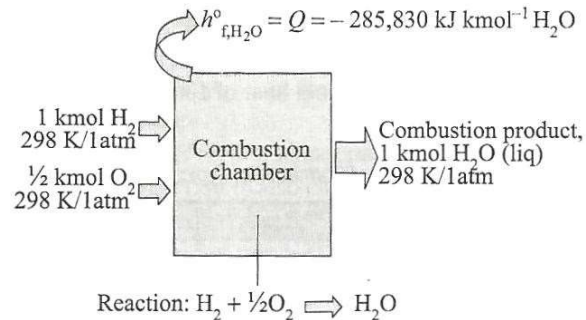

After combustion:

Since the combustion process is exothermic, heat must be removed from the combustion chamber to allow the product H₂O leave at standard condition.

2. Formation of Carbon dioxide:

Consider a combustion chamber into which are introduced 1 kmol of C and 1 kmol of O₂ - both at 298K/1atm temperature.

Before combustion:

Enthalpy of elemental C and O₂ at 298K, 1atm is zero. i.e. the enthalpy of the mixture of carbon and oxygen prior to the combustion process is zero.

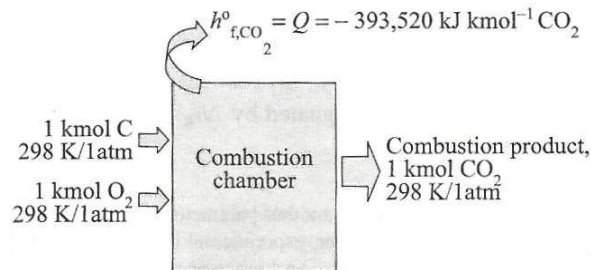

After combustion:

Since the combustion process is exothermic, heat must be extracted from the combustion chamber to allow the product CO₂ leave at standard conditions(298K/1atm)

Determination of Enthalpy of Formation:

Applying the first law to the formation of a chemical substance:

$$Q = H_p - H_r$$

Where H_p = total enthalpy of product

H_r = total enthalpy of the reactants

Subscripts R and P refer to reactants and product.

NAME – HEMANT BARICK

DESIGNATION-SR. Lect.

Mechanical Engineering Department

A more general expression of this reaction will be

$$Q = \sum_P N_i h_i - \sum_R N_i h_i$$

Where N_i stands for the molar flow rate of component i , h_i represents the molar specific enthalpy of constituent i , i.e., the difference between the enthalpy fluxes for the products and the reactants is the heat transfer rate during a chemical process.

Now, if this chemical process leads to the formation of a specified chemical compound, the enthalpy of the reactant elements can be set equal to zero at the Standard reference state. And as such the heat transfer for the process equals the specific enthalpy of the compound multiplied by its flow rate. This very quantity is the same as the enthalpy of formation of the said compound for the reaction occurring at the standard reference condition of 298 K/1 atm,

The enthalpy of formation of water (see above)

= heat transfer to the surroundings
(as determined by using a constant pressure calorimeter)

= 285,830 KJ Kmol of H₂O(liq) formed

Since the reaction is exothermic,

$$H = -285,830 \text{ KJ Kmol H}_2\text{O}(1)$$

The enthalpy of formation of carbon dioxide (see above)

= heat transfer to the surroundings
= 393,522 KJ Kmol of CO₂ formed

Since the reaction is exothermic,

$$h_0 = -393,522 \text{ KJ Kmol CO}_2$$

ENTHALPY OF REACTION:

The chemical energy which is stored as the potential Energy in the bond between the constituent atoms is either released or absorbed during a chemical reaction.

The total enthalpy change associated with a chemical reaction when the temperature of the products equals the temperature of the reactants is called the enthalpy of the reaction at that temperature. It is designated by H_g .

Such a change is depicted in fig. 13.3. It portrays the enthalpy versus temperature profile of an exothermic reaction in which the heat generated

NAME – HEMANT BARICK

DESIGNATION-SR. Lect.

Mechanical Engineering Department

is transferred to the surrounding to set the reaction proceed at a fixed temperature.

Since $Q = H$ for a constant pressure process, the enthalpy of reaction is also called heat of reaction at constant pressure or simply the heat of reaction . for a reaction at the standard reference state (298K/1atm):

This implies that the enthalpy of reaction at the standard reference state depends only on the Enthalpies of formation of the reactants/products and their number of moles.

HEAT OF COMBUSTION:

The heat of combustion of a fuel is the enthalpy of stoichiometric combustion of the fuel when

1 kmol of fuel is burned with 100% theoretical air at a constant pressure at given reference state.

The enthalpy of combustion at a specified reference state is the same as the enthalpy of combustion reaction of the fuel with air at the same specified reference state. It is designated as

HEATING VALUES FOR FUELS:

Fuels are of various kind. They are compared on the basis of their heating values.

The heating value of a fuel is the quantity of heat that is evolved when 1 kmol or Kg of the fuel

is completely burned in air (in a steady-flow process) at the standard reference state(298 K\1atm).

$HV_f = -hc$

Where HV_f stands for heating value of the fuel.

Now, as and when a hydrocarbon fuel is burned. Water is produced along with CO_2 . When the H_2O

in the produced is liquid ,i.e., $H_2O (l)$,the heating value is called higher heating value(HHV).the heating

Value when the H_2O products is vapour, i.e., $H_2O (g)$ is referred to as lower heating value (HLV).

Steady flow systems

NAME – HEMANT BARICK

DESIGNATION-SR. Lect.

Mechanical Engineering Department

THERMAL ENGINEERING - II

Consider a steady flow system with a chemical reaction taking place within the control volume.

While there is practically a negligible change in the Kinetic and potential energies between

The inlet and exit stream (fig.13.4).state I represents the state of the state of the reactants just

Before the reaction, while state of the products just after the reaction. With the KE and PE factor

Gone. The overall energy balance leads to.

NAME – HEMANT BARICK

DESIGNATION-SR. Lect.

Mechanical Engineering Department

CHAPTER-4



HEAT TRANSFER

Syllabus:

Modes of heat transfer
Fourier law of heat conduction, thermal conductivity
Steady state heat conduction in solids (Plane wall, hollow cylinder, hollow sphere)
Convective heat transfer, Newton's law of cooling
Radiation heat transfer, Stefan Boltzman Law
Theories of radiation: Maxwell's theory, Max Planck's theory; Black body radiation
Surface absorption, reflection and transmission
Kirchoff's law relating to spectral emissive power to absorptivity
Heat exchangers: concept, application and classification

MODES OF HEAT TRANSFER:

CONDUCTION:-

A physical law for heat transfer by conduction is given by fourier according to which the rate of heat conduction is proportional to the area measured normal to the direction of heat flow, and to the temp. gradient in that direction.

$$Q = - kA \frac{\delta T}{\delta n}$$

$$\text{or } q = - k \cdot \frac{\delta T}{\delta n}$$

NAME – HEMANT BARICK

DESIGNATION-SR. Lect.

Mechanical Engineering Department

THERMAL ENGINEERING - II

The constant of proportionality is called the coefficient of thermal conductivity, which is a physical property of the substance and is defined as the ability of a substance to conduct heat.

The quantity of heat transferred per unit time per unit area of isothermal surface is defined as the heat flux is determined by the relation

$$Q = - n_i \cdot k \frac{\delta T}{\delta n}$$

The heat flux q , is normal to the isothermal surface, and is positive in the direction of decreasing temp. because according to the second law of thermodynamics, heat always flow from a hotter point to a colder one. Hence .the vectors $\text{grad } T$ and q are both normal to isotherms but run in opposite directions. This also explains the existence of the minus sign in equation.

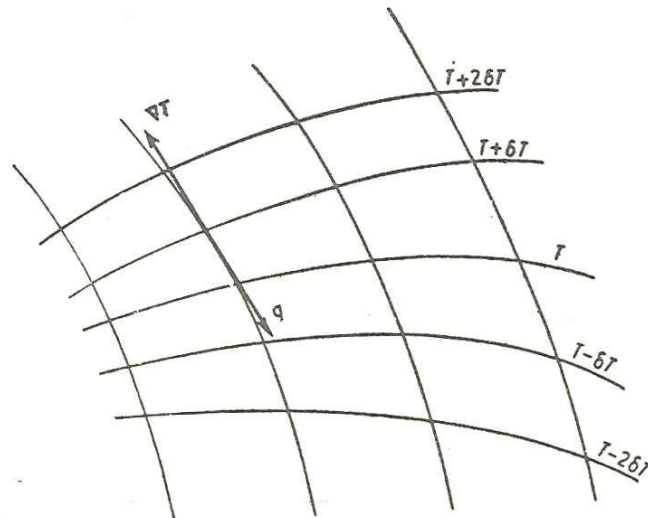

Fig. 1.2 Lines of Heat Flow and Isotherms

The greatest rate of heat flow will be along the lines normal to the isothermal surfaces. Then, in accordance with equation we have

$$Q_X = - K_X \cdot A \frac{\delta T}{\delta X} \quad \text{or} \quad q_x = \frac{Q_X}{A} = - K_X \cdot \frac{\delta T}{\delta X}$$

$$Q_Y = - K_Y \cdot A \frac{\delta T}{\delta Y} \quad \text{or} \quad q_y = \frac{Q_Y}{A} = - K_Y \cdot \frac{\delta T}{\delta Y}$$

$$Q_Z = - K_Z \cdot A \frac{\delta T}{\delta Z} \quad \text{or} \quad q_z = \frac{Q_Z}{A} = - K_Z \cdot \frac{\delta T}{\delta Z}$$

NAME – HEMANT BARICK

DESIGNATION-SR. Lect.

Mechanical Engineering Department

THERMAL ENGINEERING - II

A material having $K_X = K_Y = K_Z = K$ is called an isotropic material. For an isotropic material, the heat transfer equation reduces to $Q_X = -K_A \cdot \frac{\delta T}{\delta K}$

The heat flow vector q can be written as; $q = i.q_x + j q_y + k q_z$

For a plane wall of thickness L with temp. T_0 and T_L on its two sides integration of equation yields:

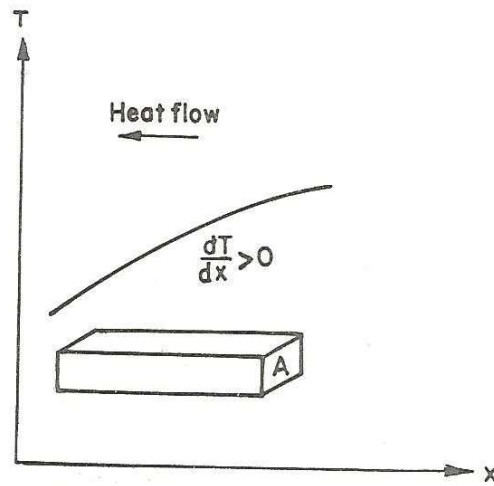

Fig. 1.3 One-Dimensional Conduction

$$Q_X \int_0^L dx = -kA \int_{T_0}^{T_L} dT$$

$$Q_X = \frac{kA}{L}(T_0 - T_L)$$

The unit of thermal conductivity k , is W/m or $W/m.k$

Since conduction is a molecular phenomenon, Fourier law is similar to Newton's

viscosity law for laminar flow: $\tau = \mu \cdot \frac{du}{dy}$

Thermal conductivity is a physical property of a substance and like viscosity, it is primarily a function of temp. and/or position, nature of the substance. It varies significantly with pressure only in the case of gases subjected to high pressure.

However for many engineering problems, materials are often considered to possess a constant thermal conductivity.

NAME – HEMANT BARICK

DESIGNATION-SR. Lect.

Mechanical Engineering Department

THERMAL ENGINEERING - II

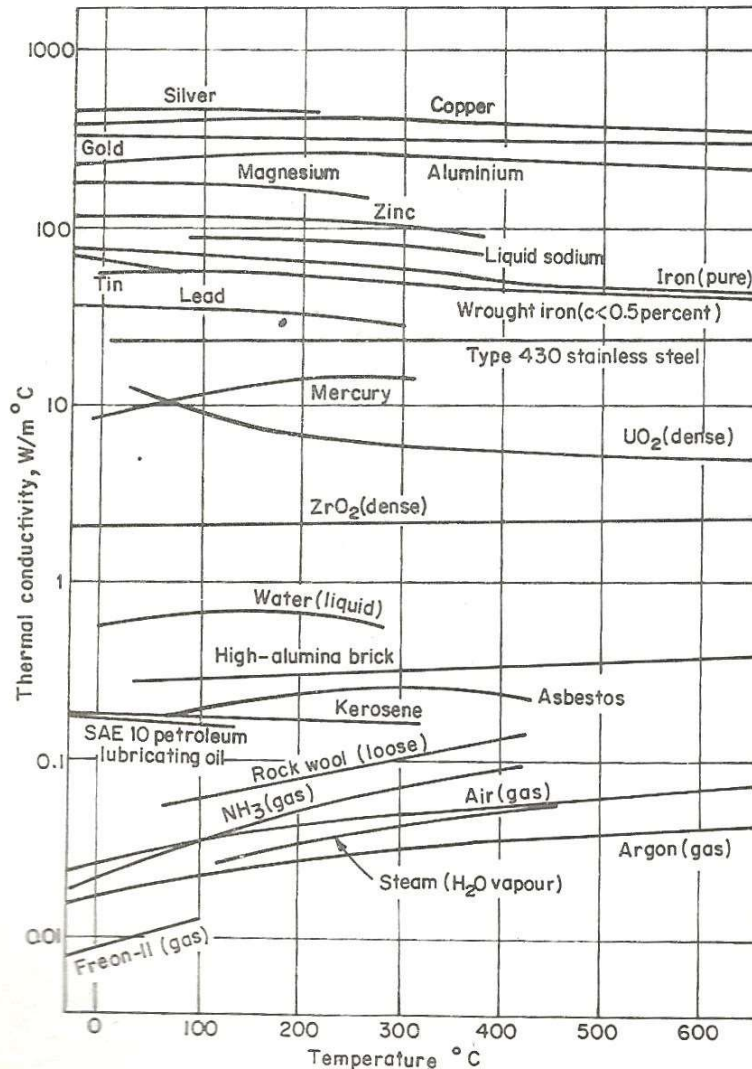

Fig. 1.4 Thermal Conductivity of Some Engineering Materials.

The thermal conductivity for most materials can be determined experimentally by measuring the rate of heat flow and temp. gradient of the substance most commonly used.

From table, We see that pure metals have the highest value of thermal conductivities while gases and vapours have the lowest; insulating materials and inorganic liquids have thermal conductivities that lie in between those of metals and gases.

NAME – HEMANT BARICK

DESIGNATION-SR. Lect.

Mechanical Engineering Department

THERMAL ENGINEERING - II

Table 1.1 Thermal Conductivities of Common Substances at 20 °C

<i>Substance</i>	<i>k(W/mK)</i>
Silver, pure	407.0
Copper pure	386.0
Aluminium, pure	175.6
Mild Steel	37.2
Lead	29.8
Stainless Steel	19.3
Wood	0.15
Asbestos, fibre	0.095
Water	0.51
Air	0.022

Thermal conductivity is also a function of temperature. For most pure metals it decreases with increasing temp, whereas for gases and insulating materials it increases with rise in temp. . Appendix A gives the thermal conductivity and other physical properties of some the most commonly used substances.

NAME – HEMANT BARICK
DESIGNATION-SR. Lect.
Mechanical Engineering Department

THERMAL ENGINEERING - II

EXAMPLE 1

A stainless steel plate 2 cm thick is maintained at a temperature of 550°C at one face and 50°C on the other. The thermal conductivity of stainless steel at 300°C is 19.1 W/m·K. Compute the heat transferred through the material per unit area.

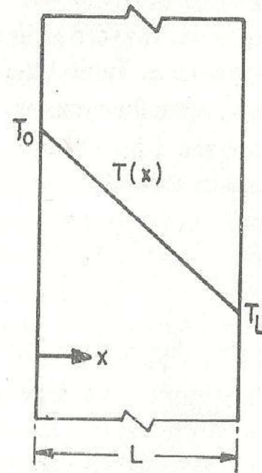

Fig. Ex. 1.1 Example 1.1

Solution This is the case of a plane wall as shown in Fig. Ex. 1.1. Using Eq. (1.12),

$$Q_x = \frac{kA}{L} (T_0 - T_L)$$

or $\frac{Q_x}{A} = q_x = \frac{k}{L} (T_0 - T_L) = \frac{(19.1)(550 - 50)}{2 \times 10^{-2}} = 477.5 \text{ kW/m}^2$ ✓

CONVECTION:

For a fluid flowing at a mean temp. T_∞ over a surface at a temp. T_s , Newton proposed the following heat convection equation; $q = \frac{Q}{A} = h(T_s - T_\infty) = h\Delta T$

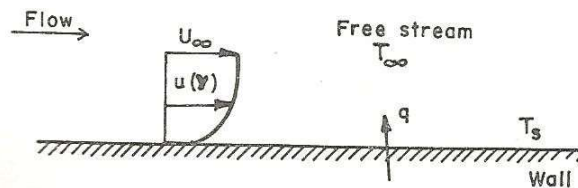

Fig. 1.5 Convection from a Heated Plate

NAME – HEMANT BARICK

DESIGNATION-SR. Lect.

Mechanical Engineering Department

THERMAL ENGINEERING - II

Where q is the heat flux at the wall. This equ. is called newton law of cooling. The heat transfer coefficient h has units W/m^2 or $W/m^2 K$ when

the heat flux q is given in the units of $\frac{W}{M^2}$ and the temp. in .

In fig. it is seen that the viscosity of fluid layer at the wall is zero so the heat must be transferred only by conduction over there. Thus we may use to compute heat transfer at the wall. Then question arises , why consider convection at all when we can easily compute q by conduction. The answer is simple; the temp. gradient is dependent upon the rate at which the fluids carries the heat away, which in turn depends upon viscosity and other thermal properties of the fluid. Comparing these equations at the wall, $h = - \frac{k}{T_s - T_\infty} \frac{dT}{dy} |_{y=0}$.

Equation relates h with thermal conductivity and the temp. gradient at wall ,and is used in the determination of h experimentally.

It has been found that the heat transfer coefficient h varies significantly with the type of fluid and temperature . table gives the approximation ranges of convective heat transfer coefficient for forced and free convection encountered in typical engineering application.

EXAMPLE 1

A flat plate of length 1 m and width 0.5 m is placed in air stream at $30^\circ C$ blowing parallel to it. The convective heat transfer coefficient is $30 W/m^2 K$. Calculate the heat transfer if the plate is maintained at a temperature of $300^\circ C$.

Solution

$$\begin{aligned} Q &= hA (T_s - T_\infty) \\ &= (30) (1.0) (0.5) (300 - 30) \\ &= 4.05 \text{ kW.} \end{aligned}$$

THERMAL RADIATION:

According to the Stefan-boltzmann law , the radiation energy emitted by a body is proportional to the fourth power of its absolute temperature. $Q = \sigma AT_1^4$.

Where σ is called Stefan-boltzmann constant with the value of $5.6697 \times 10^{-8} \frac{W}{m^2 \cdot K^4}$, and T_1 is the surface temp. in degree Kelvin.

Consider a black body of surface area A and at an absolute temp. T_1

NAME – HEMANT BARICK

DESIGNATION-SR. Lect.

Mechanical Engineering Department

THERMAL ENGINEERING - II

~~exchanging radiation with another black body at a temp T_2 . The net heat~~
exchange is proportional to the difference in T^4 .

$$Q = \sigma A(T_1^4 - T_2^4)$$

NAME – HEMANT BARICK
DESIGNATION-SR. Lect.
Mechanical Engineering Department

THERMAL ENGINEERING - II

The real surface, like a polished metal plate, do not radiate as much as energy as a black body. The gray nature of real surfaces can be accounted for by introducing a factor ϵ is called emissivity which relates radiation between gray and black bodies.

$$Q = \sigma A \epsilon (T_1^4 - T_2^4) \quad 2$$

To account for geometry and orientation of two black surfaces exchanging radiation is modified to $Q = \sigma AF(T_1^4 - T_2^4)$

When the factor F, is called view vector, is dependent upon geometry of the two surfaces exchanging radiation.

EXAMPLE 1

A 'radiator' in a domestic heating system operates at a surface temperature of 55°C. Determine the rate at which it emits radiant heat per unit area if it behaves as a black body.

Solution

$$\frac{Q}{A} = q = \sigma T^4 = 5.6697 \times 10^{-8} (273 + 55)^4 = 0.66 \text{ kW/m}^2$$

FOURIER LAW OF HEAT CONDUCTION:-

$$Q = -kA \frac{dT}{dx}$$

Where Q= amount of heat flow through the body in a unit time

A= surface area of heat flow

dT= temperature difference on the two faces of body

dx= thickness of the body through which the heat flows. It is taken along the direction of heat flow

k= constant of proportionality known as thermal conductivity of the body

THERMAL CONDUCTIVITY:-

$$Q = \frac{kA(T_1 - T_2)t}{x}$$

The thermal conductivity of a material is numerically equal to the quantity of heat which flows in one second through a slab of material of area 1 m² and thickness 1 m when its faces differ in temperature by 1 k.

NAME – HEMANT BARICK

DESIGNATION-SR. Lect.

Mechanical Engineering Department

THERMAL ENGINEERING - II

Example 1. The glass windows of a room have a total area of 10 m^2 and the glass is 4 mm thick. Calculate the quantity of heat that escapes from the room by conduction per second when the inside surfaces of windows are at 25° C and the outside surfaces at 10° C . The value of k is 0.84 W/m K .

Solution. Given : $A = 10 \text{ m}^2$; $x = 4 \text{ mm} = 0.004 \text{ m}$; $T_1 = 25^\circ \text{ C} = 298 \text{ K}$; $T_2 = 10^\circ \text{ C} = 283 \text{ K}$; $k = 0.84 \text{ W/m K}$

We know that the quantity of heat that escapes from the room per second,

$$Q = \frac{k A (T_1 - T_2)}{x} = \frac{0.84 \times 10 (298 - 283)}{0.004} = 31500 \text{ J}$$
$$= 31.5 \text{ kJ Ans.}$$

HEAT CONDUCTION THROUGH PLANE WALLS:-

Consider a plane wall of materials of uniform thermal conductivity k , which is assumed to be extending to infinity in y and z directions. For this problems, the temp. is only a function of x . the walls of a room may be considered as a plane if energy lost through the edges is negligible. Starting the general conduction

equation $\frac{\partial^2 T}{\partial x^2} + \frac{\partial^2 T}{\partial y^2} + \frac{\partial^2 T}{\partial z^2} + \frac{q}{k} = \frac{1}{\alpha} \frac{\partial T}{\partial t}$

For this case $\frac{\partial T}{\partial t} = 0$ (steady state)

$$\frac{\partial^2 T}{\partial y^2} = \frac{\partial^2 T}{\partial z^2} = 0 \text{ (one-dimensional)} \quad , \frac{q}{k} = 0 \text{ (no heat generation)}$$

The conduction equation simplifies to $\frac{\partial^2 T}{\partial x^2} = 0$ or $\frac{d^2 T}{dx^2} = 0$ ------(1)

Above equation is a second order differential equation requiring two boundary conditions for its solution.

These are $T = T_1$ at $x = 0$

$$T = T_2 \text{ at } x = L$$

Integrating this above equation twice , we get $T = C_1 x + C_2$

Where C_1 and C_2 can be determined from the boundary conditions

NAME – HEMANT BARICK

DESIGNATION-SR. Lect.

Mechanical Engineering Department

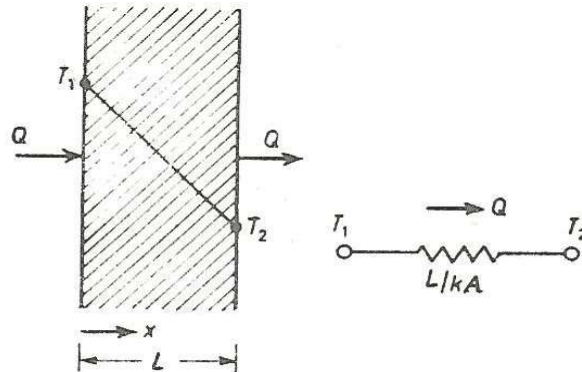

Fig. 3.1 Steady State Conduction Through a Plane Wall

At $x = 0$, $T = T_1$, so that $C_2 = T_1$

At $x = L$, $T = T_2$, so that $T_2 = C_1L + T_1$

$$\text{Or } C_1 = \frac{T_2 - T_1}{L}$$

So the equation for temp. distribution becomes $T = \frac{T_2 - T_1}{L}x + T_1$

$$\text{Or } \frac{dT}{dx} = \frac{T_2 - T_1}{L} \quad \therefore Q = -K.A \frac{dT}{dx} = \frac{-kA(T_2 - T_1)}{L} = \frac{kA(T_1 - T_2)}{L} \dots\dots\dots$$

.....(2)

This quantity of heat Q, must be supplied to the low face of the wall to maintain a temp. difference

$(T_1 - T_2)$ across it. The thermal resistance is defined for a plane wall is $R_{th} = \frac{L}{KA}$

Equation -2 can also be obtained by fourier equation, $Q = -KA \frac{dT}{dx} \dots\dots\dots$

(3)

Integrating this equation between the boundaries of the plane wall,

$$\text{we get } \int_0^L Q dx = -kA \int_{T_1}^{T_2} dT$$

$$QL = -KA(T_2 - T_1)$$

$$\text{Or } Q = \frac{-kA(T_2 - T_1)}{L}$$

NAME – HEMANT BARICK
 DESIGNATION-SR. Lect.
 Mechanical Engineering Department

$\frac{kA(T_1 - T_2)}{L}$
THERMAL ENGINEERING - II

NAME – HEMANT BARICK
DESIGNATION-SR. Lect.
Mechanical Engineering Department

THERMAL ENGINEERING - II

The temp. at any point x along the wall can be obtained by integrating equation-3 between 0 and x

$$Q \cdot x = -KA(T - T_1)$$

and comparing with equation-2, $T = \frac{(T_2 - T_1) \cdot x}{L} + T_1$

HEAT CONDUCTION THROUGH HOLLOW CYLINDER:-

Consider a long cylinder of inside radius r_i , outside radius r_o , and length L. We consider the cylinder to be long so that the end losses are negligible. The inside and outside surfaces are kept at constant temperature T_i and T_o respectively. A steam pipe in a room can be taken as an example of a long hollow cylinder. The general heat conduction equation in cylindrical coordinates is

$$\frac{\partial^2 T}{\partial r^2} + \frac{1}{r} \left(\frac{\partial T}{\partial r} \right) + \frac{1}{r^2} \frac{\partial^2 T}{\partial \theta^2} + \frac{\partial^2 T}{\partial z^2} + \frac{q}{k} = \frac{1}{\alpha} \frac{\partial T}{\partial t}$$

Assuming the heat flows only a radial directions, the above equation under steady state takes the form:

$$\frac{\partial^2 T}{\partial r^2} + \frac{1}{r} \left(\frac{\partial T}{\partial r} \right) = 0$$

$$\text{or } \frac{d}{dr} \left(r \frac{dT}{dr} \right) = 0$$

Subject to the boundary conditions, $T = T_1$ at $r = r_1$

$$T = T_0 \text{ at } r = r_0$$

Integrating twice we get, $T = C_1 \ln r + C_2$ ----- (1)

Using the boundary conditions, at $r = r_1$, $T = T_1$; $T_1 = C_1 \ln r_1 + C_2$

$$\text{at } r = r_0, T = T_0; T_0 = C_1 \ln r_0 + C_2$$

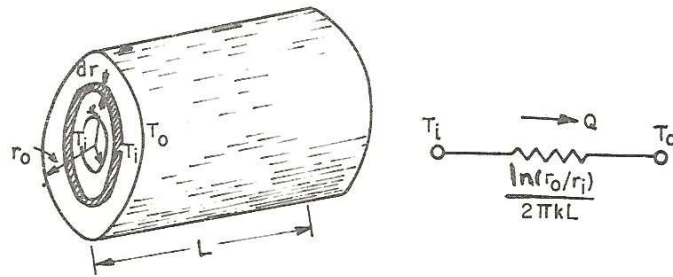

Fig. 3.2 Steady State Conduction through a Hollow Cylinder

NAME – HEMANT BARICK
DESIGNATION-SR. Lect.
Mechanical Engineering Department

THERMAL ENGINEERING - II

$$\begin{aligned}
 C_1 &= \frac{T_1 - T_0}{\ln \frac{r_0}{r_1}} \ln r_1 \\
 &= \frac{T_0 - T_1}{\ln \frac{r_1}{r_0}} \\
 C_2 &= T_1 - \frac{T_0 - T_1}{\ln \frac{r_0}{r_1}} \ln r_1 \\
 &= \frac{T_1 \ln r_0 - T_0 \ln r_1}{\ln \frac{r_0}{r_1}}
 \end{aligned}$$

Substituting the values of C_1 and C_2 in equation -1 ,

$$T = \frac{T_0 - T_1}{\ln \frac{r_1}{r_0}} \ln r + \frac{T_1 \ln r_0 - T_0 \ln r_1}{\ln \frac{r_0}{r_1}}$$

$$Q = -KA_r \frac{dT}{dr} \quad | \quad r = r_i$$

$$= -K \cdot 2\pi r_1 L \cdot \frac{C_1}{R_1} = -K \cdot 2\pi r_1 L (T_0 - T_1) \cdot \frac{1}{r_i \ln \frac{r_0}{r_1}}$$

$$= \frac{2\pi KL(T_1 - T_0)}{\ln \frac{r_0}{r_1}} \quad \text{-----(2)}$$

Equation-2 can alternatively be derived as follows:

$$Q = -KA \frac{dT}{dr}, \text{ where } A = 2\pi rL$$

$$\text{Or } Q \cdot \frac{dr}{r} = -2\pi KLdT$$

Integration of this equation gives

$$Q \cdot \int_{r_1}^{r_0} \frac{dr}{r} = -2\pi KL \int_{T_1}^{T_0} dT$$

$$Q \cdot (\ln \frac{r_0}{r_1}) = -2\pi KL (T_0 - T_1)$$

$$Q = \frac{2\pi KL(T_1 - T_0)}{\ln \frac{r_0}{r_1}}$$

The thermal resistance for the hollow cylinder would be, $R_{th} = \frac{\ln \left(\frac{r_0}{r_1}\right)}{2\pi KL}$

NAME – HEMANT BARICK

DESIGNATION-SR. Lect.

Mechanical Engineering Department

THERMAL ENGINEERING - II

HEAT CONDUCTION THROUGH HOLLOW SPHERE:

Consider a hollow sphere whose inside and outside surfaces are held at constant temperature T_1 and T_0 respectively. If the temperature is only in the radial direction, then for steady state conditions with no heat generation, the heat conduction equation simplifies to

$$\frac{62T}{6r^2} + \frac{2}{r} \left(\frac{6T}{6r} \right) = 0$$

Multiplying through by r^2 , we get $r^2 \cdot \frac{62T}{6r^2} + 2r \cdot \frac{6T}{6r} = 0$

$$\text{Or} \quad \frac{d}{dr} \left(r^2 \frac{dT}{dr} \right) = 0 \text{-----(1)}$$

Integration of equation-1 gives $dT = C_1 \frac{dr}{r^2}$

Integrating again, we get $T = \frac{-C_1}{r} + C_2$

Applying the boundary conditions,

$$T = T_1 \text{ at } r = r_1; \quad T_1 = \frac{-C_1}{r_1} + C_2$$

$$T = T_0 \text{ at } r = r_0; \quad T_0 = \frac{-C_1}{r_0} + C_2$$

Solving for C_1 and C_2

$$C_1 = \frac{T_1 - T_0}{\frac{1}{r_0} - \frac{1}{r_1}}, \quad C_2 = T_1 + \frac{1}{r_1} \frac{T_1 - T_0}{\frac{1}{r_0} - \frac{1}{r_1}}$$

$$\therefore T = T_1 - \frac{T_1 - T_0}{\frac{1}{r_0} - \frac{1}{r_1}} \cdot \frac{1}{r} + \frac{1}{r_1} \frac{T_1 - T_0}{\frac{1}{r_0} - \frac{1}{r_1}}$$

$$= \frac{r_0}{r} \frac{T_1 - T_0}{r_0 - r_1} + [T_0 - T_1] + T_1$$

Knowing that $Q = -KA_r \frac{dT}{dr} |_{r=r_1}$,

where $A_r = 4\pi r^2$

We can know that,

$$Q = \frac{4\pi r_1 r_0 K (T_1 - T_0)}{(R_0 - R_1)} \text{-----(2)}$$

NAME – HEMANT BARICK

DESIGNATION-SR. Lect.

Mechanical Engineering Department

THERMAL ENGINEERING - II

Equation-2 can also be obtained by integration of fourier equation as follows:

NAME – HEMANT BARICK
DESIGNATION-SR. Lect.
Mechanical Engineering Department

THERMAL ENGINEERING - II

$$Q = -KA \frac{dT}{dr} = -4\pi K r^2 \frac{dT}{dr}$$

$$Q \int_{r_1}^{r_0} \frac{dr}{r^2} = -4\pi K \int_{T_1}^{T_0} dT$$

$$-Q \left[\frac{1}{r_0} - \frac{1}{r_1} \right] = -4\pi K [T_0 - T_1]$$

$$\text{Or, } -Q \left(\frac{r_1 - r_0}{r_0 r_1} \right) = -4\pi K [T_0 - T_1]$$

$$\text{And, } Q = \frac{4\pi r_0 r_1 K (T_1 - T_0)}{(r_0 - r_1)} \quad (3)$$

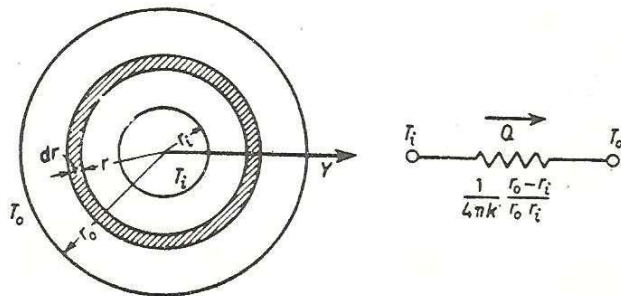

Fig. 3.3 Steady State Conduction Through a Hollow Sphere

$$\text{Equation-3 can also be put as, } Q = \frac{(T_1 - T_0)}{\frac{1}{4\pi K} \left[\frac{r_0 - r_1}{r_0 r_1} \right]}$$

$$= \frac{T_1 - T_0}{R_{sph}}$$

Where the thermal resistance of a sphere is defined as $R_{sph} = \frac{1}{4\pi K} \left[\frac{(r_0 - r_1)}{r_0 r_1} \right]$

Geometric mean area: R_{sph} can be rearranged as

$$\begin{aligned} R_{sph} &= \frac{1}{4\pi K} \left[\frac{(r_0 - r_1)}{r_0 r_1} \right] \\ &= \frac{r_0 - r_1}{K \sqrt{(4\pi r_0^2)(4\pi r_1^2)}} = \frac{L_{sph}}{A_g \cdot K} \\ &= \frac{L_{sph}}{K \cdot \sqrt{A_0 A_1}} \end{aligned}$$

NAME – HEMANT BARICK

DESIGNATION-SR. Lect.

Mechanical Engineering Department

(4)

THERMAL ENGINEERING - II

Where A_1 and A_0 are the areas of the inner and outer surfaces of the sphere.

$L_{sph} = (R_0 - R_1) =$ thickness of sphere

$A_g = \sqrt{A_0 A_1}$ is called the geometric mean area of the sphere.

The thermal resistance of a sphere given by equation-4 is similar to that of a plane wall except that the area is replaced by the geometric mean area.

NEWTON LAW OF COOLING:-

It states that, — heat transfer from a hot body to a cold body is directly proportional to the surface area and difference of temperature between the bodies.

It is a general law, for the heat transfer which can not be applied to all sets of condition. But it paved the way for other laws dealing in the heat loss.

ABSORPTION, REFLECTION, AND TRANSMISSION:-

When incident radiation is called irradiation impinges on a surface, three things happen; a part is reflected back, a part is transmitted through and the remainder is absorbed, depending upon the characteristics of the body.

By conservation of energy particle, $G_a + G_r + G_t = G$

Dividing both sides by G , we get , $\frac{G_a}{G} + \frac{G_r}{G} + \frac{G_t}{G} = \frac{G}{G}$

So, $a + \rho + r = 1$

Black body:- For perfectly absorbing body, $a = 1$, $\rho = 0$, $r = 0$. Such a body is called black body. it is one which neither reflect nor transmit any part of the incident radiation but absorb all of it.

White body:- If all the incident radiation falling on a body are reflected, it is called white body. Gases such as hydrogen, oxygen, nitrogen have a transmittivity of practically unity.

Gray body:- If the radiative properties of a body are assumed to be uniform over the entire wavelength spectrum, then such a body is called gray body. It is also defined as one whose absorptivity of a surface does not vary with temperature and wavelength of the incident radiation.

NAME – HEMANT BARICK

DESIGNATION-SR. Lect.

Mechanical Engineering Department

THERMAL ENGINEERING - II

CONCEPT OF BLACK BODY:- A black body is an object that absorbs all the radiant energy reaching its surface. No actual body is perfectly black; a black body has following properties:

1. It absorbs all the incident radiation falling on it and does not transmit or reflect regardless of wavelength and direction
2. It emits maximum amount of heat radiation at all wavelength at any specified temperature.
3. It is a diffuse emitter .

KIRCHHOFF'S LAW:-

The law states that any temp.the ratio of total emissive power E to the total absorpivity a is a constant for all substances which are in thermal equilibrium with their environment.

Let us consider a large radiating body of surface area A which encloses a small body of surface area A_1 . let the energy fall on the unit surface of the body at a rate E_b .by considering generality of bodies, we obtain, $E_b = \frac{E_1}{a_1} = \frac{E_2}{a_2} = \frac{E}{a}$

Also , as per the definition of emissivitys , we have $s = \frac{E}{E_b}$. By comparing ,we

obtain , $s = a$

PLANCK;S LAW :-

NAME – HEMANT BARICK

DESIGNATION-SR. Lect.

Mechanical Engineering Department

THERMAL ENGINEERING - II

In 1900 Max Planck showed by quantum arguments that the spectral distribution of the radiation intensity of a black body is given by

$$(E_{\lambda})_b = \frac{2\pi c^2 h \lambda^{-5}}{\exp\left(\frac{ch}{\lambda k T}\right) - 1} \quad \dots \text{ (Planck's law)} \quad \dots (11.14)$$

where, $(E_{\lambda})_b$ = Monochromatic (single wavelength) emissive power of a black body,
 c = Velocity of light in vacuum, $2.998 \times 10^8 \approx 3 \times 10^8$ m/s
 h = Planck's constant = 6.625×10^{-34} j.s
 λ = Wavelength, μm
 k = Boltzmann constant = 1.3805×10^{-23} J/K, and
 T = Absolute temperature, K

Hence the unit of $(E_{\lambda})_b$ is $W/m^2 \cdot \mu m$.

Quite often the Planck's law is written as

$$(E_{\lambda})_b = \frac{C_1 \lambda^{-5}}{\exp\left(\frac{C_2}{\lambda T}\right) - 1} \quad \dots (11.15)$$

where, $C_1 = 2\pi c^2 h = 3.742 \times 10^8$ $W \cdot \mu m^4 / m^2$;

$$C_2 = \frac{ch}{k} = 1.4388 \times 10^4 \mu m K$$

Equation (11.14) is of great importance as it provides quantitative results for the radiation from a black body.

NAME – HEMANT BARICK

DESIGNATION-SR. Lect.

Mechanical Engineering Department

THERMAL ENGINEERING - II

MAXWELL EQUATION:-

Now let us derive the Maxwell's equation.

We know that for a system undergoing an infinitesimal reversible process from one equilibrium state to another :

$$1. \text{ Internal energy, } \quad dU = \delta Q - \delta W \quad \dots \text{ (General gas energy equation)}$$

$$\quad \quad \quad = T dS - p dv \quad \dots \text{ (} \because \delta Q = T dS \text{ and } \delta W = p dv \text{)} \quad \dots \text{ (i)}$$

The above equation (i) is of the form

$$dz = M dx + N dy$$

where $M = T, N = -p, x = S$ and $y = v$

$$\therefore \left(\frac{\partial T}{\partial v} \right)_S = - \left(\frac{\partial p}{\partial S} \right)_v \quad \dots \text{ (ii)}$$

$$2. \text{ Enthalpy, } \quad dH = dU + d(pv)$$

$$\quad \quad \quad = dU + p dv + v dp$$

$$\quad \quad \quad = (T dS - p dv) + p dv + v dp \quad \dots \text{ (} \because dU = T dS - p dv \text{)}$$

$$\quad \quad \quad = T ds + v dp \quad \dots \text{ (iii)}$$

The above equation (iii) is of the form

$$dz = M dx + N dy$$

where $M = T, N = v, x = S$ and $y = p$

$$\therefore \left(\frac{\partial T}{\partial p} \right)_S = \left(\frac{\partial v}{\partial S} \right)_p \quad \dots \text{ (iv)}$$

3. Helmholtz function (A),

$$dA = dU - d(TS)$$

$$\quad \quad \quad = dU - T dS - S dT$$

$$\quad \quad \quad = (T dS - p dv) - T dS - S dT \quad \dots \text{ (} \because dU = T dS - p dv \text{)}$$

$$\quad \quad \quad = -p dv - S dT \quad \dots \text{ (v)}$$

The above equation (v) is of the form

$$dz = M dx + N dy$$

where $M = -p, N = -S, x = v, y = T$

$$\therefore - \left(\frac{\partial p}{\partial T} \right)_v = - \left(\frac{\partial S}{\partial v} \right)_T$$

$$\text{or} \quad \left(\frac{\partial p}{\partial T} \right)_v = \left(\frac{\partial S}{\partial v} \right)_T \quad \dots \text{ (vi)}$$

$$4. \text{ Gibbs function (G), } \quad dG = dH - d(TS)$$

$$\quad \quad \quad = dH - T dS - S dT$$

$$\quad \quad \quad = (T dS + v dp) - T dS - S dT \quad \dots \text{ (} \because dH = T dS + v dp \text{)}$$

$$\quad \quad \quad = v dp - S dT \quad \dots \text{ (vii)}$$

The above equation (vii) is of the form

$$dz = M dx + N dy$$

where $M = v, N = -S, x = p, y = T$

$$\therefore \left(\frac{\partial v}{\partial T} \right)_p = - \left(\frac{\partial S}{\partial p} \right)_T \quad \dots \text{ (viii)}$$

The equations (ii), (iv), (vi) and (viii) are known as *Maxwell's equations* in thermodynamics.

NAME – HEMANT BARICK

DESIGNATION-SR. Lect.

Mechanical Engineering Department

HEAT EXCHANGER:-

It may be defined as an equipment which transfer the energy from a hot fluid to a cold fluid, with maximum rate and minimum investment and running cost.

In heat exchanger the temperature of each fluid changes it passes through the exchangers, and hence the temperature of the dividing wall between the fluids also changes along the length of the exchanger.

CLASSIFICATION OF HEAT EXCHANGER:-

1. NATURE OF HEAT EXCHANGER PROCESS:-
 - (i) Direct contact heat exchanger
 - (ii) Indirect contact heat exchanger
 - (a) Regenerators
 - (b) Recuperators
2. RELATIVE DIRECTION OF FLUID MOTION:-
 - (i) Parallel flow
 - (ii) Counter flow
 - (iii) Cross flow
3. DESIGN AND CONSTRUCTIONAL FEATURES:-
 - (i) Concentric tube
 - (ii) Shell and tube
 - (iii) Multiple shell and tube passes
 - (iv) Compact heat exchanger
4. PHYSICAL STATE OF FLUIDS:-
 - (i) Condenser
 - (ii) Evaporator

NAME – HEMANT BARICK

DESIGNATION-SR. Lect.

Mechanical Engineering Department

CHAPTER-5

REFRIGERATION CYCLES

Syllabus:

Concept of refrigerators and heat pumps
Reversed Carnot cycle and its limitations
Ideal vapor compression refrigeration cycle
Actual vapor compression refrigeration cycle
Gas refrigeration cycle

REFRIGERATORS AND HEAT PUMPS:

Heat flows down the temperature gradient, that is from a high temperature to low temperature .this follows from 2nd law of thermodynamics. So the reverse process Carnot occurs by itself. However this can be achieved by a special device called refrigerator.

NAME – HEMANT BARICK

DESIGNATION-SR. Lect.

Mechanical Engineering Department

THERMAL ENGINEERING - II

Refrigerators are cyclic devices that use refrigerant as working fluid and it requires an input energy to drive the refrigerator.

The refrigerator picks up Q_L amount of heat from the cold space T_L and delivers Q_H amount of heat to the warm environment T_H . There is another device that transfer heat from a low temp. medium to high temp. one. it is called heat pump. Both heat pump and refrigerator perform the same duty-to remove heat from a cold region and deliver it to a warm region. Both require a work input to operate. but they differ only their objectives. The performance of refrigerators and heat pump is expressed in terms of a parameter called co-efficient of performance (COP), which is the desired objective upon the required input:

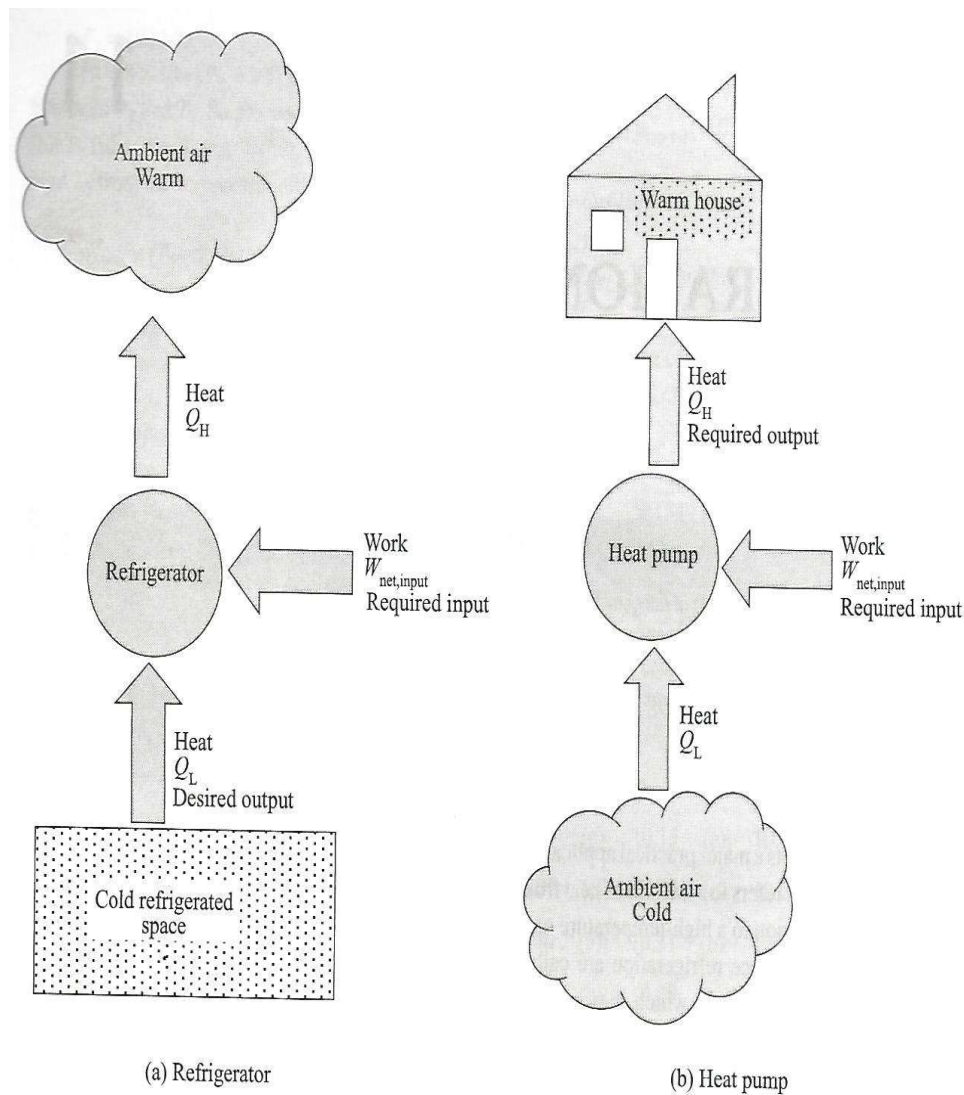

NAME – HEMANT BARICK

DESIGNATION-SR. Lect.

Mechanical Engineering Department

$$\begin{aligned}\text{COP}_{\text{rf}} &= \frac{\text{desired output}}{\text{required input}} \\ &= \frac{\text{cooling effect}}{\text{work input}}\end{aligned}$$

$$\begin{aligned}\text{COP}_{\text{hp}} &= \frac{\text{desired output}}{\text{required input}} \\ &= \frac{\text{heating effect}}{\text{work input}}\end{aligned}$$

$$\begin{aligned}\text{Now, } \text{COP}_{\text{hp}} - \text{COP}_{\text{rf}} &= \frac{Q_H - Q_L}{W_{\text{net,in}}} \\ &= \frac{W_{\text{net,in}}}{W_{\text{net,in}}} = 1\end{aligned}$$

$$\text{Or } \text{COP}_{\text{hp}} = \text{COP}_{\text{rf}} + 1$$

Since COP_{rf} is a quantity, COP_{hp} is greater than 1

The cooling capacity of a refrigeration system implies its rate of heat removal of refrigerated space. It is often expressed in terms of tons of refrigeration. one ton defines the capacity of a given refrigeration system to freeze 1 ton of water at 0°C in 24h. this is equivalent to the extraction of $3.5 \frac{\text{kJ}}{\text{sec}}$ of heat.

REVERSED CARNOT CYCLE:

A Carnot cycle, which comprises two reversible isothermal and two isentropic processes, is an ideal cycle. any heat engine operating in a Carnot cycle registers the maximum thermal efficiency. the heat engine takes up heat from high temp. source and transfer the heat to a low temp. sink, while delivering some positive work output.

NAME – HEMANT BARICK

DESIGNATION-SR. Lect.

Mechanical Engineering Department

THERMAL ENGINEERING - II

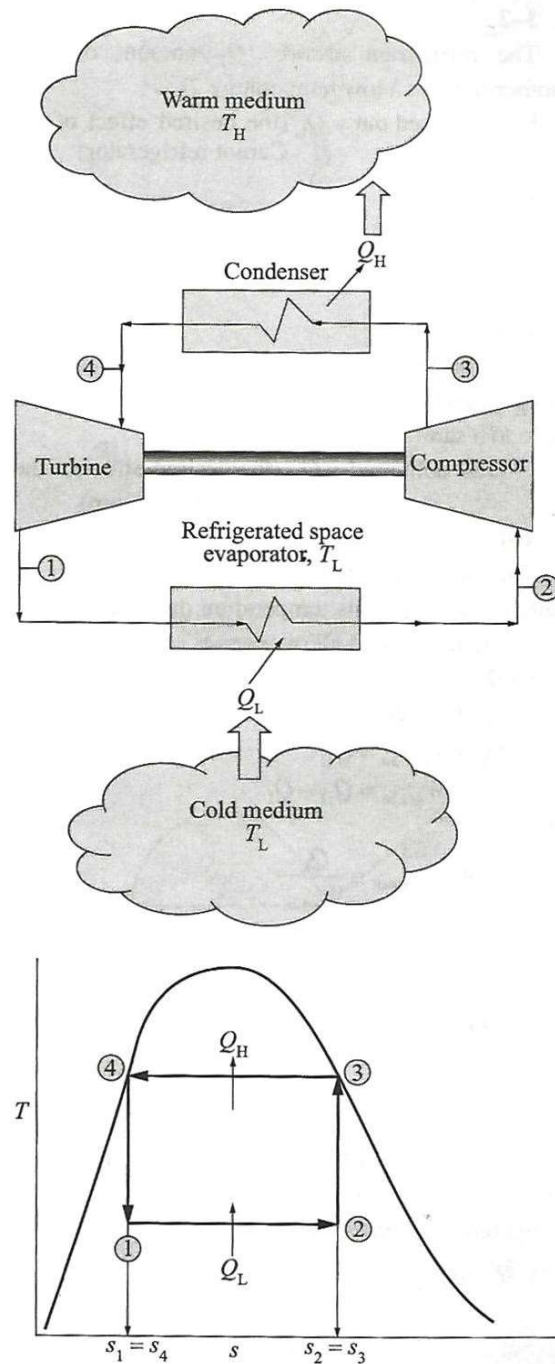

Since it is a reversible cycle, all four processes comprising the Carnot cycle can be reversed. Reversing the Carnot cycle also reverses the direction of flow of heat and work. This means, operating in a reversed Carnot cycle one can pump heat

NAME – HEMANT BARICK

DESIGNATION-SR. Lect.

Mechanical Engineering Department

THERMAL ENGINEERING - II

from a low temp. body to high temp. one.

NAME – HEMANT BARICK

DESIGNATION-SR. Lect.

Mechanical Engineering Department

THERMAL ENGINEERING - II

When this reversed Carnot cycle is operated by using a refrigerator or heat pumps, the result is a cycle that operates in the counter clockwise direction in a T-S diagram. And the refrigerator or heat pump is called a Carnot refrigerator or Carnot heat pump.

Process 1-2:

The refrigerant absorbs Q_L amount of heat isothermally at a low temp. T_L .

Heat pumped out = Q_L (the desired effect of the Carnot refrigerator)

Process 2-3:

The working fluid is then compressed isentropically to state 3 where upon its temp. rises to T_H .

Process 3-4:

The working fluid then rejects heat Q_h isothermally at T_H where upon it changes from a saturated vapour state to a saturated liquid state. heat delivered = Q_H

Process 4-1:

The refrigerant then expands isentropically to state 1 whereupon its temp. drops to T_L . and the cycle is repeated all over again.

COP;- From the energy balance:

$$Q_L + W_{\text{net,in}} = Q_h$$

$$\text{or, } W_{\text{net,in}} = Q_h - Q_L$$

$$\text{hence, } \text{COP}_{\text{Prf, Carnot}} = \frac{Q_L}{Q_H - Q_L}$$

$$\text{COP}_{\text{hp, Carnot}} = \frac{Q_H}{Q_H - Q_L}$$

The co-efficient of performance of Carnot refrigerators and heat pumps can be expressed in terms of temp. parameters:

$$\text{COP}_{\text{Prf, Carnot}} = \frac{Q_L}{Q_H - Q_L} = \frac{T_L}{T_H - T_L}$$

$$\text{COP}_{\text{Prf, Carnot}} = \frac{Q_H}{Q_H - Q_L} = \frac{T_H}{T_H - T_L}$$

Second law of efficiency

NAME – HEMANT BARICK

DESIGNATION-SR. Lect.

Mechanical Engineering Department

THERMAL ENGINEERING - II

$$\eta_2^{\text{nd}} =$$

$$\frac{\text{minimum energy supplied to the refrigerated space to accomplish a specified task}}{\text{actual energy input required for accomplishing the said task}}$$

Now, the energy input rate $\chi_{\text{input}} = m_{\text{fuel}} \cdot \chi_c$

Where m_{fuel} = rate of fuel burning

$\cdot \chi_c$ = chemical energy per unit mass of the fuel. However, this is not equal to the fuel energy released in the combustion chamber, which is

Energy supplied by fuel = $m_{\text{fuel}} \text{HV}$

Again not all this liberated energy translates into generator heating rate (QG) (not the fuel gas leaving the stack is at a higher temperature and hence higher heat load than the atmospheric air). Therefore, introducing the burner

efficiency. $\eta_{\text{burner}} = \frac{Q_g}{m_{\text{fuel}} \text{HV}}$

If it is assumed that $T_L \sim T_o$ (a rather simple case), then the second law efficiency of the overall absorption system (all operation inclusive) is

$$\begin{aligned} \eta_2^{\text{nd}} &= \frac{w_{\text{optimum}}}{\chi_{\text{input}}} \\ &= \frac{w_{\text{optimum}}}{Q} \cdot \left[\frac{Q}{Q_g} \right] \left[\frac{Q_g}{m_{\text{fuel}} \text{HV}} \right] \left[\frac{\text{HV}}{\chi_c} \right] \\ &= \frac{\text{COP}_{\text{actual}}}{\text{COP}_{\text{optimum}}} \cdot \frac{\text{burner}\%}{100} \cdot \frac{\text{HV}}{\chi_c} \end{aligned}$$

The COP optimum is that for a device operating in a reversed Carnot cycle.

NAME – HEMANT BARICK

DESIGNATION-SR. Lect.

Mechanical Engineering Department

THERMAL ENGINEERING - II

IDEAL VAPOUR COMPRESSION REFRIGERATION CYCLE:

The vapour compression refrigeration cycle is mostly used cycle in refrigerators,air conditioning systems,and of course,heat pumps.it is the reversed constant pressure cycle,also known as bell-coleman cycle.it comprises two adiabatics and two constant pressure lines.these four stages are:

NAME – HEMANT BARICK
DESIGNATION-SR. Lect.
Mechanical Engineering Department

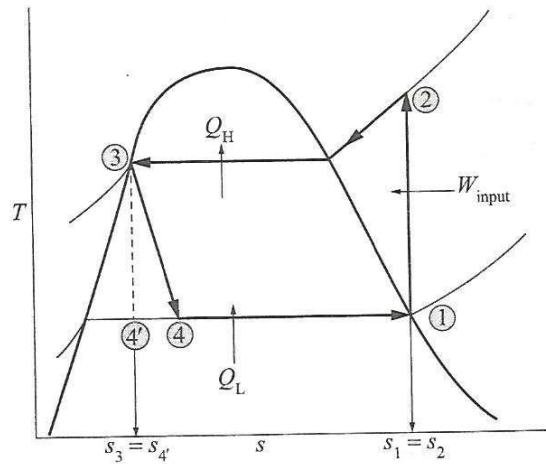
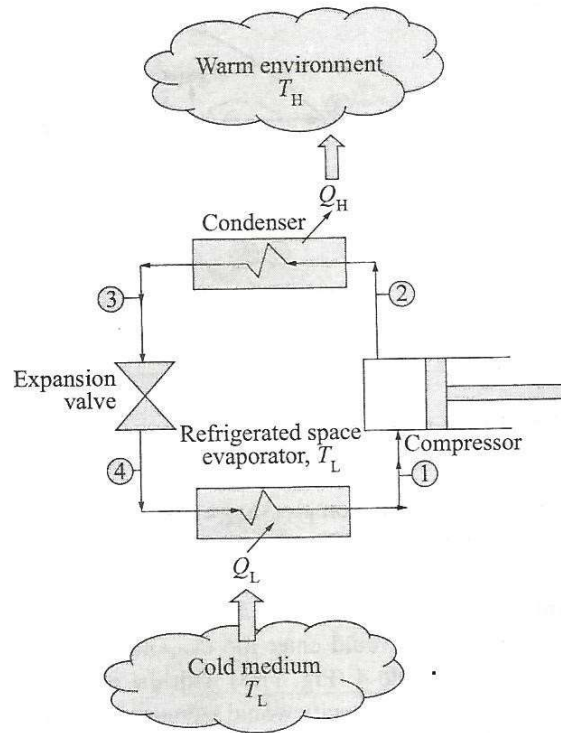

Fig. 11.3 Schematic presentation of a vapour compression refrigeration system and the corresponding T - s diagram.

NAME – HEMANT BARICK
 DESIGNATION-SR. Lect.
 Mechanical Engineering Department

Process 1-2

Isentropic compression:- this is a reversible process in which a saturated vapour, at state 1, is compressed isentropically to the condenser pressure. The temp. of the refrigerant rises as the compression continues till it goes well above the temp. of the surrounding medium.

Process 2-3

Cooling and condensation:- this is yet another reversible stage as the refrigerant enters the condenser as a superheated vapour and leaves as a saturated liquid as a consequence of heat rejection to the surroundings. The liquid refrigerant, still at a high temp. than the surroundings, leaves the condenser.

Process 3-4

Throttling:- this is an adiabatic expansion. The saturated liquid refrigerant at state 3 is passed through an expansion valve whereupon the temp. of the refrigerant drops from T_3 to T_4 , which is below the temp. of the refrigerated space.

Process 4-1

Evaporation: this constant pressure reversible process completes the cycle. During this process, the refrigerant is completely evaporated by abstracting heat from the refrigerated space and then it leaves the evaporator as a saturated vapour and re-enters the compressor only to repeat the cycle all over again.

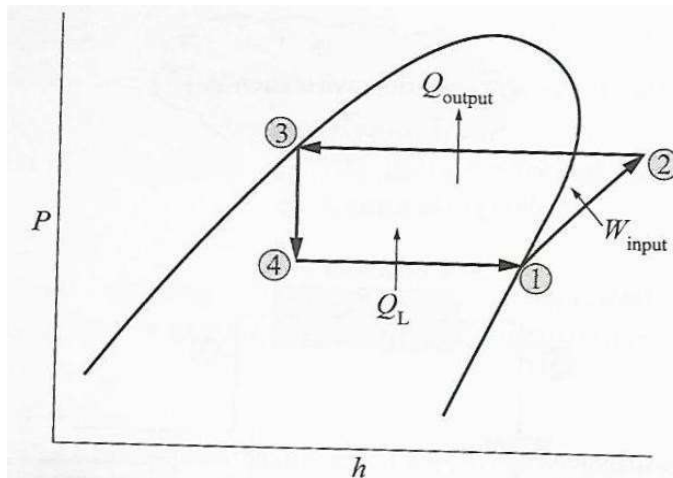

Fig. 11.4 P-h diagram of an ideal vapour compression refrigeration cycle.

NAME – HEMANT BARICK

DESIGNATION-SR. Lect.

Mechanical Engineering Department

THERMAL ENGINEERING - II

Apart from the T-S diagram, there is another diagram that is most frequently used: a P-h diagram. the P-h diagram of an ideal vapour compression refrigeration cycle.

The ideal vapour compression cycle is not an internally reversible cycle as it embodies a throttling process, which is an irreversible one. If this throttling device is replaced by an expansion turbine, the refrigerant would enter the evaporator at state 4 with the effect that the refrigeration capacity would increase .thermodynamics analysis

The steady flow energy equation on a unit mass basis:

$$(Q_{in}-Q_{out}) + (W_{in}-W_{out}) = h_e - h_i$$

$$COP_{RF} = \frac{Q_L}{W_{net,in}} = \frac{h_1-h_4}{h_2-h_1}$$

$$COP_{HP} = \frac{Q_H}{W_{net,in}} = \frac{h_2-h_3}{h_2-h_1}$$

Refrigerating effect:

$$\text{Refrigerating effect} = m C_p(T_1-T_4)$$

Input energy:

$$\begin{aligned} \text{Energy rejected (process 2-3)} \\ = m C_p(T_2 - T_3) \end{aligned}$$

Energy supplied:

$$\begin{aligned} &= \text{energy rejected-refrigerating effect} \\ &= m C_p(T_2 - T_3) - m C_p(T_1 - T_4) \end{aligned}$$

$$\begin{aligned} \text{Co-efficient of performance, COP} &= \frac{m C_p(T_1-T_4)}{m C_p(T_2-T_3)-m C_p(T_1-T_4)} \\ &= \frac{(T_1-T_4)}{(T_2-T_3)-(T_1-T_4)} \end{aligned}$$

Now, points 1 and 2 lie on the same adiabetic,

$$\text{so, } T_3 =$$

NAME – HEMANT BARICK

DESIGNATION-SR. Lect.

Mechanical Engineering Department

T_4

$\frac{P_3}{P_4} = \frac{T_3}{T_4} = \frac{1}{\gamma}$ — THERMAL ENGINEERING - II

NAME – HEMANT BARICK
DESIGNATION-SR. Lect.
Mechanical Engineering Department

THERMAL ENGINEERING - II

Likewise, points 1 and 2 lie on the same adiabatic curve $PV^\gamma = C$.

$$\text{so, } \frac{T_2}{T_1} = \frac{P_2 V_2^{-\frac{1}{\gamma}}}{P_1}$$

Therefore, $T_3/T_4 = T_2/T_1$

$$\text{Or } T_3 = \frac{T_4 T_2}{T_1}$$

$$\begin{aligned} \text{Hence, COP} &= \frac{T_1 - T_4}{(T_2 - \frac{T_4 T_2}{T_1}) - (T_1 - T_4)} \\ &= \frac{T_1(T_1 - T_4)}{T_2(T_1 - T_4) - T_1(T_1 - T_4)} \\ &= \frac{T_1}{T_2 - T_1} \end{aligned}$$

ACTUAL VAPOUR COMPRESSION REFRIGERATION CYCLE:

An ideal vapour compression refrigeration cycle is reversible one, whereas the actual cycle is irreversible one. Two common sources of irreversibilities are: * fluid friction bringing about a pressure loss

* heat transfer to or from the surroundings

The T-s diagram of an actual vapour compression refrigeration cycle is shown in fig.

NAME – HEMANT BARICK

DESIGNATION-SR. Lect.

Mechanical Engineering Department

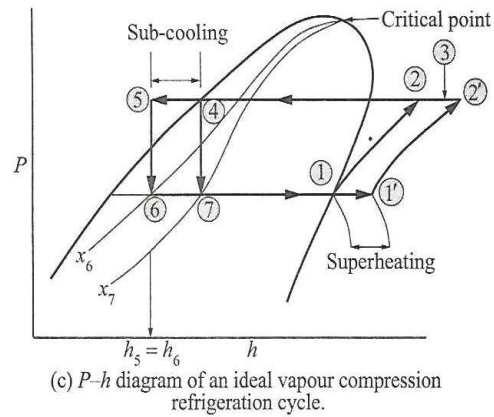
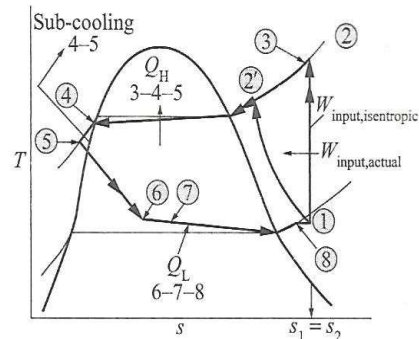
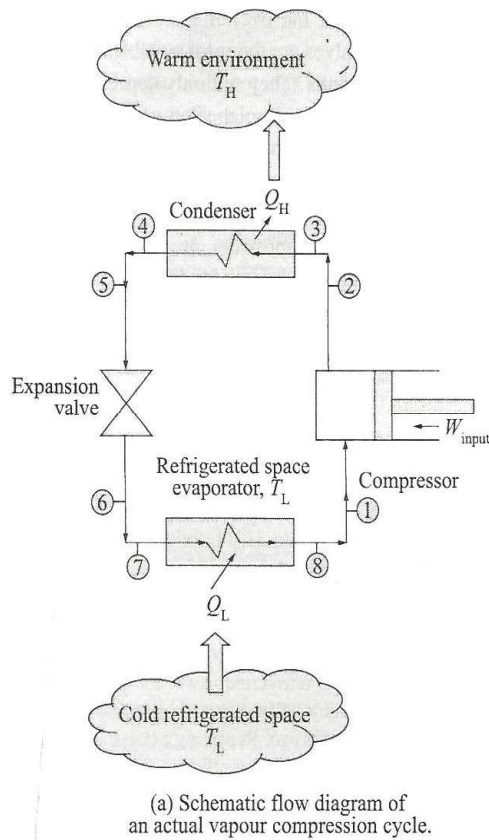

ANALYSIS OF AN ACTUAL VAPOUR COMPRESSION REFRIGERATION CYCLE VIS-À-VIS AN IDEAL CYCLE:

The ideal cycle starts with a saturated vapour, the evaporator exists as a saturated refrigerant vapour, which is charged to the compressor. However, in practice, it may not be possible to control the state of the refrigerant so precisely. Instead, it is easier to design the system so that the refrigerant vapour enters the compressor with a little degree of superheat. This slight overdesign ensures that the refrigerant is completely vaporised before it enters the compressors.

Over and above, the refrigerant header from the evaporator to the compressor inlet is usually very long. This results in a significant pressure drop plus a considerable amount of heat ingress from the surroundings to the refrigerant.

THERMAL ENGINEERING - II

The foregoing three factors result in a considerable increase in the specific volume of the refrigerant and with that power input requirement to drive the compressor increases.

The compression stage in an ideal cycle is reversible, adiabatic, and thus isentropic. However, the actual compression process is not adiabatic. A frictional heat loss occurs which increases the entropy. Besides, heat transfer to or from the surroundings occurs, which may increase or decrease the entropy, depending on the directions of heat flow. As a result of the compression, the entropy of the refrigerant may increase or decrease depending on which effect dominates. The compression stage 1-2' is more desirable than 1-2 since it ends with a lower temp. of the fluid and hence a smaller specific volume refrigerant that requires a smaller amount of the compressor power input. This makes it imperative why the refrigerant is to be cooled during the compression stage whenever it is practical and economical to do so.

In the ideal cycle, the refrigerant is supposed to leave the condenser completely as a saturating liquid. Nevertheless, some pressure drop in the condenser as well as in the refrigerant header from the condenser to expansion valve is unavoidable. Besides, it is very difficult to execute the condenser process to completion so that the entire refrigerant exist the condenser as a saturating liquid. It is operationally not admissible to route the refrigerant to the throttling valve before the refrigerant is completely condensed. To overcome this bottleneck, the refrigerant is sub-cooled to state 5 before it expands the the expansion valve. (process 5-6). Sub-cooling is a bonanza as it renders the liquid refrigerant to enter the evaporator at a lower enthalpy and thus can absorb more heat from the refrigerated space. To reduce the degree of pressure drop, the expansion valve and the evaporator are located close to each other.

\

NAME – HEMANT BARICK

DESIGNATION-SR. Lect.

Mechanical Engineering Department

GAS REFRIGERATION CYCLES:

The reversed brayton cycle is a gas refrigeration cycle. One such cycle is shown in fig in which the refrigerated space is to be maintained at T_L while the surrounding air is at T_0 . its corresponding T-s diagram is shown in fig.

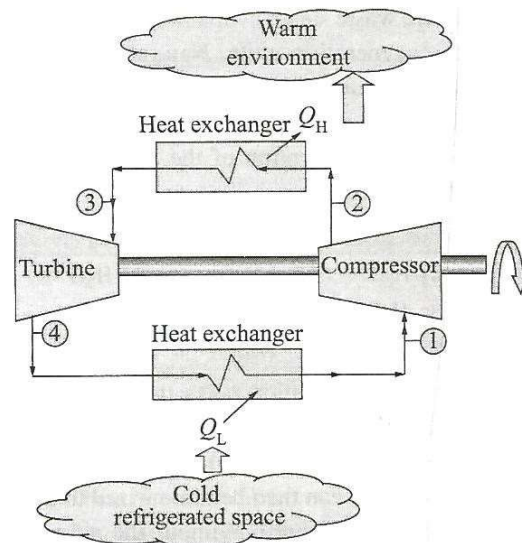

(a) Schematic diagram of a simple gas refrigeration cycle

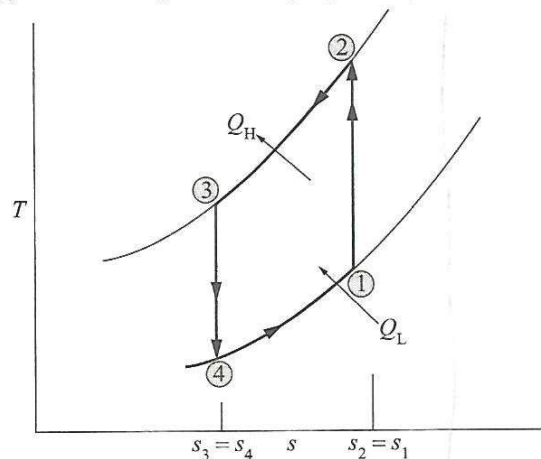

(b) T-s diagram of a simple gas refrigeration cycle

■ 1→2 ADIABATIC COMPRESSION:

The exit gas is at high temp. and pressure.

NAME – HEMANT BARICK

DESIGNATION-SR. Lect.

Mechanical Engineering Department

■ 2→3 ISOBARIC COOLING

NAME – HEMANT BARICK
DESIGNATION-SR. Lect.
Mechanical Engineering Department

THERMAL ENGINEERING - II

Constant pressure cooling to T_0 by rejecting heat to the ambient air.

■ 3→4 ADIABATIC EXPANSION:

Adiabatic expansion in the turbine whereupon the temp. drops to T_4 .

■ 4→1 REFRIGERATION:

Finally, the cold gas stream is allowed to circulate through the refrigerated space to abstract Q_L amount of heat until its temp. rises to T_1 , which is then routed to the compressor inlet to repeat the cycle.

All the processes described are internally reversible and hence the cycle represents an ideal gas refrigeration cycle. However, the actual GRC is not reversible as the compression and expansion processes deviate from the isentropic ones. heat removal, Q_L

Refrigeration duty = heat removal from the refrigerated space = Q_L

\ = area under the curve 4-1

$$= H_1 - H_4$$

Work input, $W_{net,in}$ = compressor work, $W_{comp,in}$

Work output = turbine work, $W_{turb,in}$

Net work input, $W_{net,in} = W_{comp,in} - W_{turb,in}$

$$= (H_2 - H_1) - (H_3 - H_4)$$

$$COP = \frac{Q_L}{W_{net,in}}$$

The gas refrigeration cycle(GRC) deviates from a reversed carnot cycle because heat removal from the refrigerated space and heat rejection to a warmer environment are not isothermal processes whereas these are isothermal ones in a RCC. In fact the gas temps. Varies considerably during these two heat transfer processes with the effect that $COP_{GRC} < COP_{RCC}$. this is also evident from figure.

NAME – HEMANT BARICK

DESIGNATION-SR. Lect.

Mechanical Engineering Department

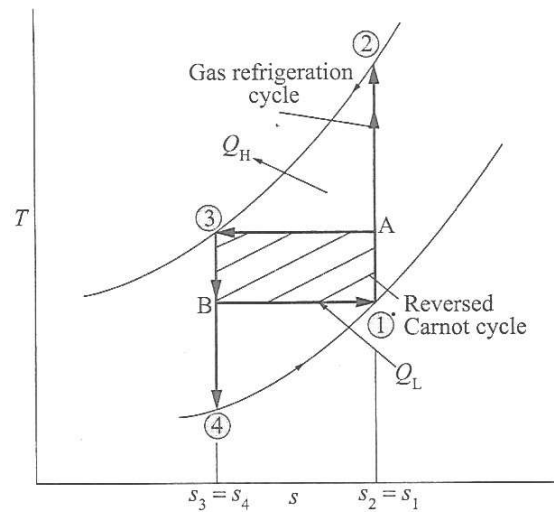

Fig. 11.12 Reversed Carnot cycle gives rises to more refrigeration (area under B-1) with a less work input (area 1-A-3-B) whereas a gas refrigeration cycle, operating between the same temperature limits, requires more work input (area 4-1-2-3) yet producing a less refrigerating effect (area under 4-1).

NAME – HEMANT BARICK
 DESIGNATION-SR. Lect.
 Mechanical Engineering Department