

GOVERNMENT POLYTECHNIC BHUBANESWAR



LECTURE NOTE

ON

ELECTRICAL MACHINETH-1

PREPARED BY ANANYA SUBHADARSHINI, Lecturer Electrical Deptd

Department of Electronics and Telecommunication
Engineering

Branch- Electronics and Telecommunication Engg.
SEMESTER- 4TH

Chapter (1)

ELECTRICAL MATERIAL

PROPERTIES AND USES OF DIFFERENT CONDUCTING MATERIALS:

Electrical conducting material are the basic requirement for electrical engineering products. The electrical conducting material can be classified as below-

Based on Resistivity or Conductivity

1. High conductivity conducting material
2. High resistivity or Low conductivity conducting material

A classification chart of conducting materials based on resistivity or conductivity is shown in figure below-

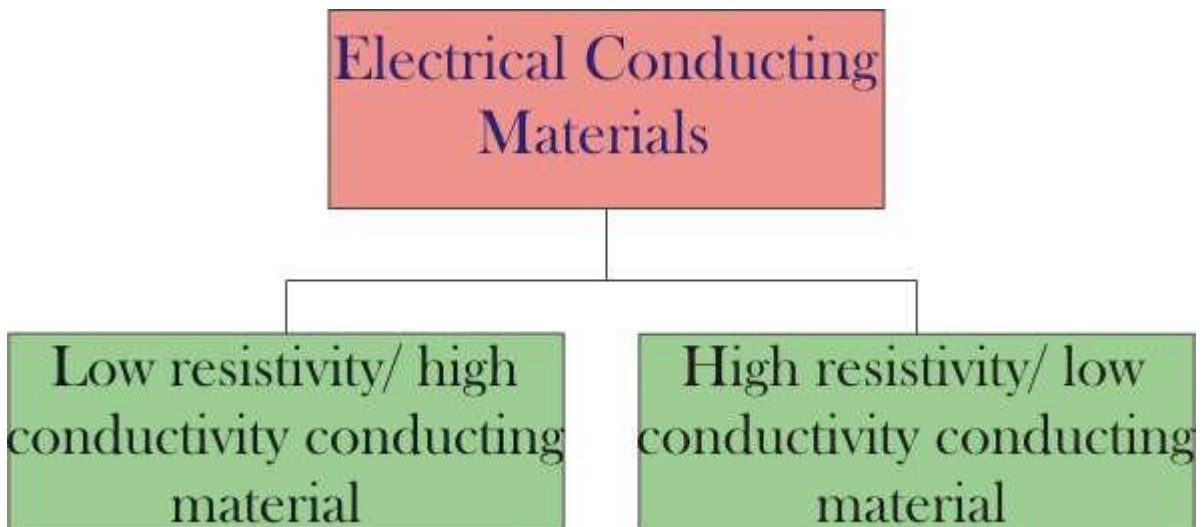

Material having low resistivity or high conductivity are very useful in electrical engineering products. These material used as conductors for all kind of windings required in electrical machines, apparatus and devices. These material are also used as conductor in transmission

and distribution of electrical energy.

Some of low resistivity or high conductivity materials and their resistivity are given in table below –

- Silver
- Copper
- Gold
- Aluminum

High Resistivity or Low Conductivity Conducting Material

Materials having High resistivity or Low conductivity conducting are very useful for electrical engineering products. These material are used to manufacture the filaments for incandescent lamp, heating elements for electric heaters, space heaters and electric irons etc.

Some of materials having High resistivity or Low conductivity are listed below:

- Tungsten
- Carbon
- Nichrome or Brightray – B
- Nichrome – Vor Brightray – C
- Manganin

Based on Area of Application

- Materials used as conductor for coils of electrical machines
- Materials for heating elements
- Materials for lamp filaments
- Material used for transmission line
- Bimetals
- Electrical Contact Materials
- Electrical Carbon Materials
- Material for Brushes used in Electrical Machines
- Materials used for fuses

A classification chart of conducting materials based on their applications is shown in figure below-

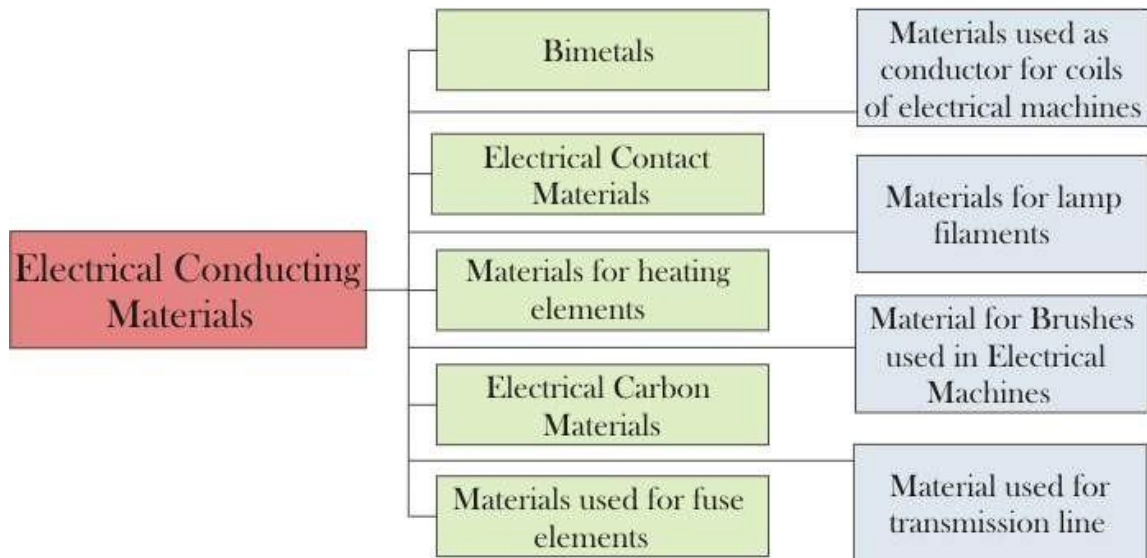

Materials Used as Conductor for Coils of Electrical Machines

Materials having low resistivity or high conductivity such as copper, silver and aluminum can be used for making coils for electrical machines. However, looking to optimum conductivity, mechanical strength and cost, copper is much suitable for making coils for electrical machines.

Materials for Heating Elements

Materials having high resistivity or low conductivity such as Nichrome, Kanthal, Cupronickel and Platinum etc. are used for making heating elements. Materials used for heating elements must possess following properties-

- High melting point
- Free from oxidation in operating atmosphere

- High tensile strength
- Sufficient ductility to draw the metal or alloy in the form of wire

Materials for Lamp Filaments

Materials having high resistivity or low conductivity such as Carbon, Tantalum and Tungsten etc. are used for making incandescent lamp filament. Materials used for making incandescent lamp filament must possess following properties-

- High melting point
 - Low vapour pressure
 - Free from oxidation in inert gas (argon, nitrogen etc.) medium at operating temperature
 - High resistivity
 - Low thermal coefficient of expansion
 - Low temperature coefficient of resistance
 - Should have high young modulus and tensile strength
 - Sufficient ductility so that can be drawn in the form of very thin wire
 - Ability to be converted in the shape of filament
 - High fatigue resistance against thermally induced fluctuating stresses
 - Cost should minimum

Material Used for Transmission Line

Materials used for making conductor for transmission line must possess following properties –

- High conductivity
- High tensile strength
- Light weight
- High resistance to corrosion
- High thermal stability
- Low coefficient of thermal expansion
- Low cost

PROPERTIES AND USES OF VARIOUS INSULATING MATERIALS USED IN ELECTRICAL ENGINEERING:

A material that responds with very high resistance to the flow of electrical current or totally resists electric current is called an insulating material. In insulating materials, the valence electrons are tightly bonded to their atoms.

In the electrical field, the purpose of any insulating material is to separate electrical conductors without passing current through it. Material like PVC, glass, asbestos, rigid laminate, varnish, resin, paper, Teflon, and rubber are very good electrical insulators. Insulating material is used as a protective coating on electrical wire and cables.

The most significant insulating material is air. Beside that solid, liquid, and gaseous type of insulators are also used in electrical systems.

Insulating material is generally used as a protective coating on electrical conductor and cables. Cable cores which touch each other should be separated and insulated by means of insulation coating on each core, e.g. polyethylene, cross linked polyethylene-XLPE, polyvinyl chloride-PVC, Teflon, silicone etc. Hanging disk insulators (bushings) are used in high voltage transmission bare cables where they are supported by electrical poles. Bushings are made from glass, porcelain, or composite polymer materials.

All electronic appliances and instruments widely contain PCB (printed circuit boards) having different electronics components on them. PCBs are manufactured of epoxy plastic and fiberglass. All electronics components are fixed on the insulated PCB board. In SCR (semiconductor rectifiers), transistors and integrated circuits, the silicon material is used as a conductive material and can be converted into insulators using a heat and oxygen process.

Transformer oil is widely used as an insulator to prevent arcing in transformers, stabilizers, circuit breakers, etc. The insulating oil can withstand insulating properties up to a specified

electrical breakdown voltage. Vacuum, gas (sulfur hexafluoride), and ceramic or glass wire are other methods of insulation in high voltage systems. Small transformers, power generators, and electrical motors contain insulation on the wire coils by the means of polymer varnish. Fiberglass insulating tape is also used as a winding coil separator.

List of some common insulating materials

- A.B.S.
- ACETATE
- ACRYLIC
- BERYLLIUM OXIDE
- CERAMIC
- DELRIN
- EPOXY/FIBERGLASS
- GLASS
- KAPTON
- KYNAR
- LEXAN
- MERLON
- MELAMINE
- MICA
- NEOPRENE
- NOMEX
- NYLON
- P.E.T. (Polyethylene terephthalate)

VARIOUS MAGNETIC MATERIALS AND THEIR USES:

All types of materials and substances possess some kind of magnetic properties which are listed further down in this article. But normally the word “magnetic materials” is used only for ferromagnetic materials (description below), however, materials can be classified into following categories based on the magnetic properties shown by them:

1. Paramagnetic materials

The materials which are not strongly attracted to a magnet are known as paramagnetic material. For example: aluminium, tin magnesium etc. Their relative permeability is small but positive. For example: the permeability of aluminium is: 1.00000065. Such materials are magnetized only when placed on a super strong magnetic field and act in the direction of the magnetic field.

Paramagnetic materials have individual atomic dipoles oriented in a random fashion as shown below:

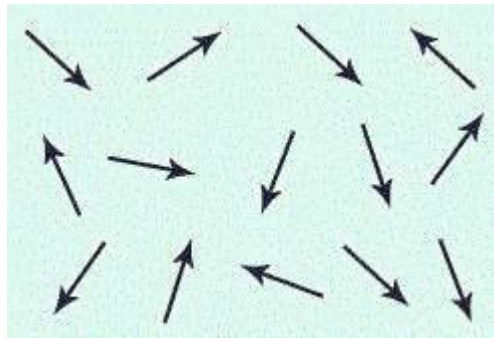

The resultant magnetic force is therefore zero. When a strong external magnetic field is applied, the permanent magnetic dipoles orient themselves parallel to the applied magnetic field and give rise to a positive magnetization. Since, the orientation of the dipoles parallel to the applied magnetic field is not complete, the magnetization is very small.

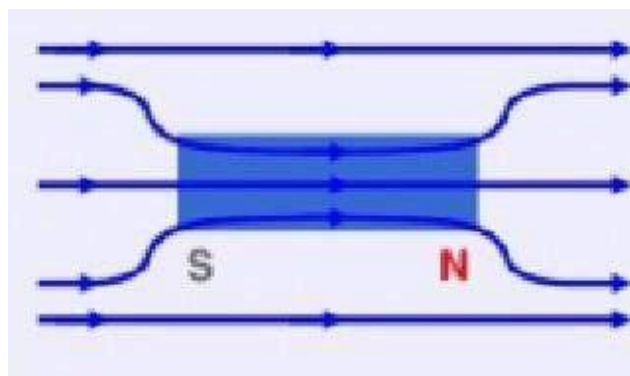

2. Diamagnetic materials

The materials which are repelled by a magnet such as zinc, mercury, lead, sulfur, copper, silver, bismuth, wood etc., are known as diamagnetic materials. Their permeability is slightly less than one. For example the relative permeability of bismuth is 0.00083, copper is 0.000005 and wood is 0.9999995. They are slightly magnetized when placed in a very strong magnetic field and act in the direction opposite to that of applied magnetic field.

In diamagnetic materials, the two relatively weak magnetic fields caused due to the orbital revolution and axial rotation of electrons around nucleus are in opposite directions and cancel each other. Permanent magnetic dipoles are absent in them, Diamagnetic materials have very little to no applications in electrical engineering.

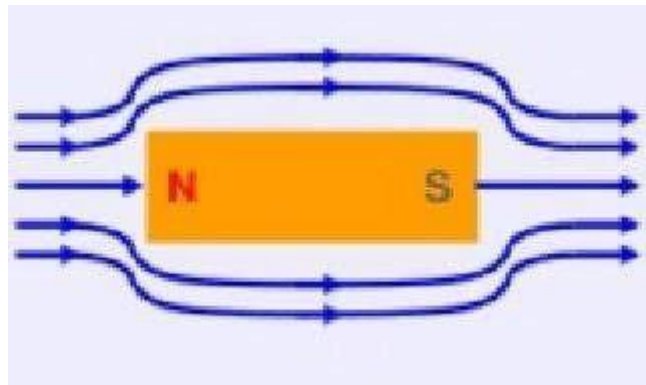

3. Ferromagnetic materials

The materials which are strongly attracted by a magnetic field or magnet is known as ferromagnetic material for eg: iron, steel, nickel, cobalt etc. The permeability of these materials is very very high (ranging up to several hundred or thousand).

The opposite magnetic effects of electron orbital motion and electron spin do not eliminate each other in an atom of such a material. There is a relatively large contribution from each atom which aids in the establishment of an internal magnetic field, so that when the material is placed in a magnetic field, its value is increased many times the value that was present in the free space before the material was placed there.

For the purpose of electrical engineering it will suffice to classify the materials as simply ferromagnetic and non-ferromagnetic materials. The latter includes material of relative permeability practically equal to unity while the former have relative permeability many times greater than unity. Paramagnetic and diamagnetic material falls in the non-ferromagnetic materials.

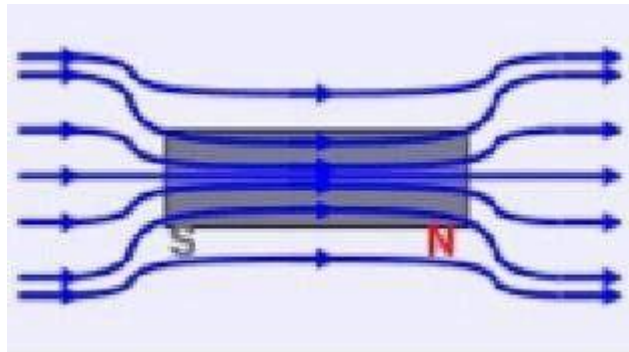

a. Soft Ferromagnetic materials

They have high relative permeability, low coercive force, easily magnetized and demagnetized and have extremely small hysteresis. Soft ferromagnetic materials are iron and its various alloys with materials like nickel, cobalt, tungsten and aluminium. ease of magnetization and demagnetization makes them highly suitable for applications involving changing magnetic flux as in electromagnets, electric motors, generators, transformers, inductors, telephone receivers, relays etc. They are also useful for magnetic screening. Their properties may be greatly enhanced through careful manufacturing and by heating and slow annealing so as to achieve a high degree of crystal purity. Large magnetic moment at room temperature makes soft ferromagnetic materials extremely useful for magnetic circuits but ferromagnetics are very good conductors and suffer energy loss from eddy current produced within them. There is additional energy loss due to the fact that magnetization does not proceed smoothly but in minute jumps. This loss is called magnetic residual loss and it depends purely on the frequency of the changing flux density and not on its magnitude.

b. Hard Ferromagnetic materials

They have relatively low permeability, and very high coercive force. These are difficult to magnetize and demagnetize. Typical hard ferromagnetic materials include cobalt steel and various ferromagnetic alloys of cobalt, aluminium and nickel. They retain high percentage of

their magnetization and have relatively high hysteresis loss. They are highly suited for use as permanent magnet as speakers, measuring instruments etc.

4. Ferrites

Ferrites are a special group of ferromagnetic materials that occupy an intermediate position between ferromagnetic and non-ferromagnetic materials. They consist of extremely fine particles of a ferromagnetic material possessing high permeability, and are held together with a binding resin. The magnetization produced in ferrites is large enough to be of commercial value but their magnetic saturation are not as high as those of ferromagnetic materials. As in the case of ferro magnetics, ferrites may be soft or hard ferrites.

a. Soft Ferrites

Ceramic magnets also called ferromagnetic ceramics, are made of an iron oxide, Fe_2O_3 , with one or more divalent oxide such as NiO , MnO or ZnO . These magnets have a square hysteresis loop and high resistance and demagnetization are valued for magnets for computing machines where a high resistance is desired. The great advantage of ferrites is their high resistivity. Commercial magnets have resistivity as high as 10^9 ohm-cm. Eddy currents resulting from an alternating fields are therefore, reduced to minimum, and the range of application of these magnetic materials is extended to high frequencies, even to microwaves. Ferrites are carefully made by mixing powdered oxides, compacting and sintering at high temperature. High-frequency transformers in televisions and frequency modulated receivers are almost always made with ferrite cores.

b. Hard Ferrites

These are ceramic permanent magnetic materials. The most important family of hard ferrites has the basic composition of $\text{MO.Fe}_2\text{O}_3$ where M is barium(Ba) ion or strontium (Sr) ion. These materials have a hexagonal structure and low in cost and density. Hard ferrites are used in generators, relays and motors. Electronic applications include magnets for loud speakers, telephone ringers and receivers. They are also used in holding devices for door closer, seals, latches and in several toy designs.

Chapter (2)

D.C. Generators

Introduction

Although a far greater percentage of the electrical machines in service are a.c. machines, the d.c. machines are of considerable industrial importance. The principal advantage of the d.c. machine, particularly the d.c. motor, is that it provides a fine control of speed. Such an advantage is not claimed by any a.c. motor. However, d.c. generators are not as common as they used to be, because direct current, when required, is mainly obtained from an a.c. supply by the use of rectifiers. Nevertheless, an understanding of d.c. generator is important because it represents a logical introduction to the behaviour of d.c. motors. Indeed many d.c. motors in industry actually operate as d.c. generators for a brief period. In this chapter, we shall deal with various aspects of d.c. generators.

Generator Principle

An electric generator is a machine that converts mechanical energy into electrical energy. An electric generator is based on the principle that whenever flux is cut by a conductor, an e.m.f. is induced which will cause a current to flow if the conductor circuit is closed. The direction of induced e.m.f. (and hence current) is given by Fleming's right hand rule. Therefore, the essential components of a generator are:

- a magnetic field
- conductor or a group of conductors
- motion of conductor w.r.t. magnetic field.

Simple Loop Generator

Consider a single turn loop ABCD rotating clockwise in a uniform magnetic field with a constant speed as shown in Fig.(1.1). As the loop rotates, the flux linking the coil sides AB and CD changes continuously. Hence the e.m.f. induced in these coil sides also changes but the e.m.f. induced in one coil side adds to that induced in the other.

- 0 When the loop is in position no. 1 [See Fig. 1.1], the generated e.m.f. is zero because the coil sides (AB and CD) are cutting no flux but are moving parallel to it

- 0 When the loop is in position no. 2, the coil sides are moving at an angle to the flux and, therefore, a low e.m.f. is generated as indicated by point 2 in Fig. (1.2).
- 1 When the loop is in position no. 3, the coil sides (AB and CD) are at right angle to the flux and are, therefore, cutting the flux at a maximum rate. Hence at this instant, the generated e.m.f. is maximum as indicated by point 3 in Fig. (1.2).
- 2 At position 4, the generated e.m.f. is less because the coil sides are cutting the flux at an angle.
- 3 At position 5, no magnetic lines are cut and hence induced e.m.f. is zero as indicated by point 5 in Fig. (1.2).
- 4 At position 6, the coil sides move under a pole of opposite polarity and hence the direction of generated e.m.f. is reversed. The maximum e.m.f. in this direction (i.e., reverse direction, See Fig. 1.2) will be when the loop is at position 7 and zero when at position 1. This cycle repeats with each revolution of the coil.

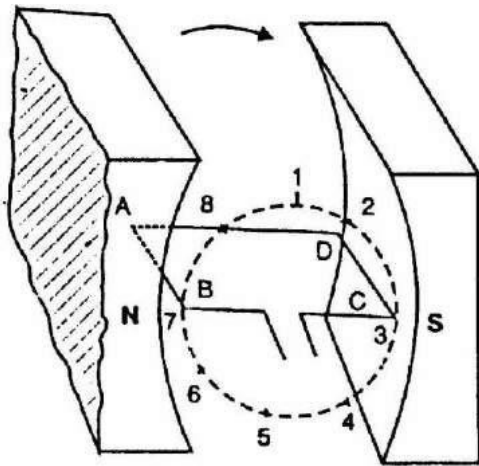

Fig. (1.1)

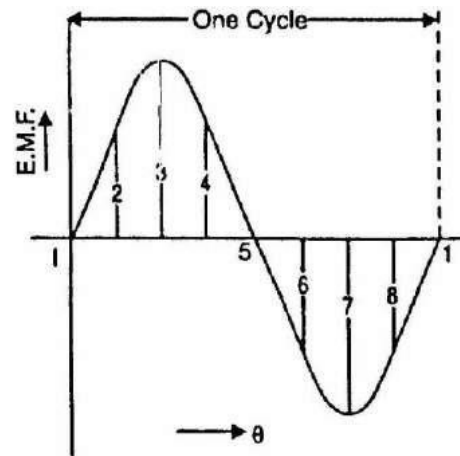

Fig. (1.2)

Note that e.m.f. generated in the loop is alternating one. It is because any coil side, say AB has e.m.f. in one direction when under the influence of N-pole and in the other direction when under the influence of S-pole. If a load is connected across the ends of the loop, then alternating current will flow through the load. The alternating voltage generated in the loop can be converted into direct voltage by a device called commutator. We then have the d.c. generator. In fact, a commutator is a mechanical rectifier.

Action Of Commutator

If, somehow, connection of the coil side to the external load is reversed at the same instant the current in the coil side reverses, the current through the load

will be direct current. This is what a commutator does. Fig. (1.3) shows a commutator having two segments C_1 and C_2 . It consists of a cylindrical metal ring cut into two halves or segments C_1 and C_2 respectively separated by a thin sheet of mica. The commutator is mounted on but insulated from the rotor shaft. The ends of coil sides AB and CD are connected to the segments C_1 and C_2 respectively as shown in Fig. (1.4). Two stationary carbon brushes rest on the commutator and lead current to the external load. With this arrangement, the commutator at all times connects the coil side under S-pole to the +ve brush and that under N-pole to the -ve brush.

- 0 In Fig. (1.4), the coil sides AB and CD are under N-pole and S-pole respectively. Note that segment C_1 connects the coil side AB to point P of the load resistance R and the segment C_2 connects the coil side CD to point Q of the load. Also note the direction of current through load. It is from Q to P.
- 1 After half a revolution of the loop (i.e., 180° rotation), the coil side AB is under S-pole and the coil side CD under N-pole as shown in Fig. (1.5). The currents in the coil sides now flow in the reverse direction but the segments C_1 and C_2 have also moved through 180° i.e., segment C_1 is now in contact with +ve brush and segment C_2 in contact with -ve brush. Note that commutator has reversed the coil connections to the load i.e., coil side AB is now connected to point Q of the load and coil side CD to the point P of the load. Also note the direction of current through the load. It is again from Q to P.

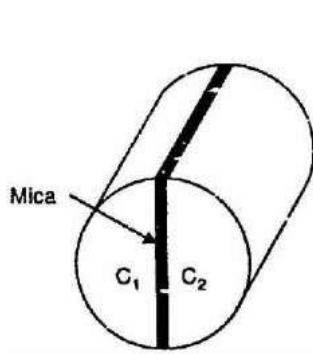

Fig.(1.3)

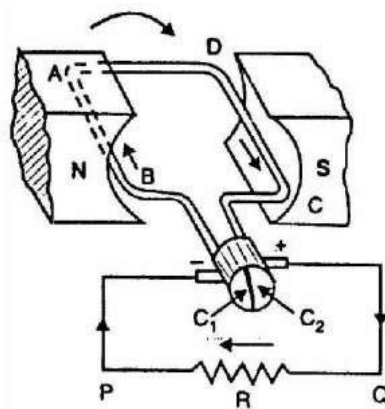

Fig.(1.4)

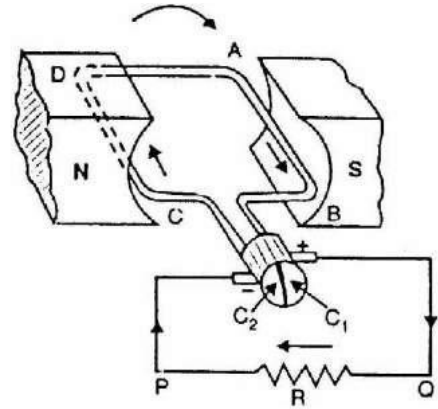

Fig.(1.5)

Thus the alternating voltage generated in the loop will appear as direct voltage across the brushes. The reader may note that e.m.f. generated in the armature winding of a d.c. generator is alternating one. It is by the use of commutator that we convert the generated alternating e.m.f. into direct voltage. The purpose of brushes is simply to lead current from the rotating loop or winding to the external stationary load.

The variation of voltage across the brushes with the angular displacement of the loop will be as shown in Fig. (1.6). This is not a steady direct voltage but has a pulsating character. It is because the voltage appearing across the brushes varies from zero to maximum value and back to zero twice for each revolution of the loop. A pulsating direct voltage such as is produced by a single loop is not suitable for many commercial uses. What we require is the steady direct voltage. This can be achieved by using a large number of coils connected in series. The resulting arrangement is known as armature winding.

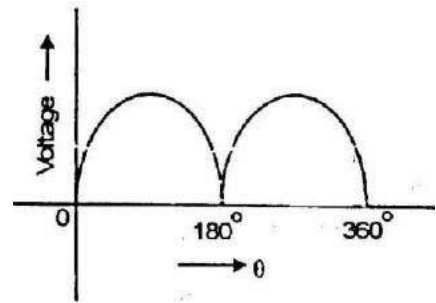

Fig. (1.6)

Construction of d.c. Generator

The d.c. generators and d.c. motors have the same general construction. In fact, when the machine is being assembled, the workmen usually do not know whether it is a d.c. generator or motor. Any d.c. generator can be run as a d.c. motor and vice-versa. All d.c. machines have five principal components viz., (i) field system (ii) armature core (iii) armature winding (iv) commutator (v) brushes [See Fig. 1.7].

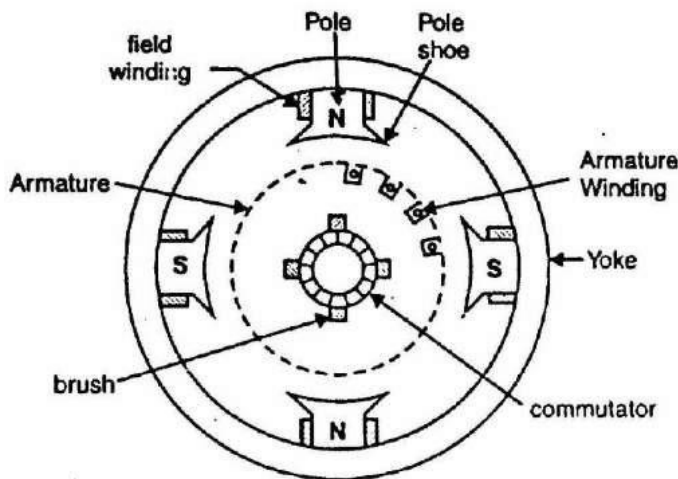

Fig. (1.7)

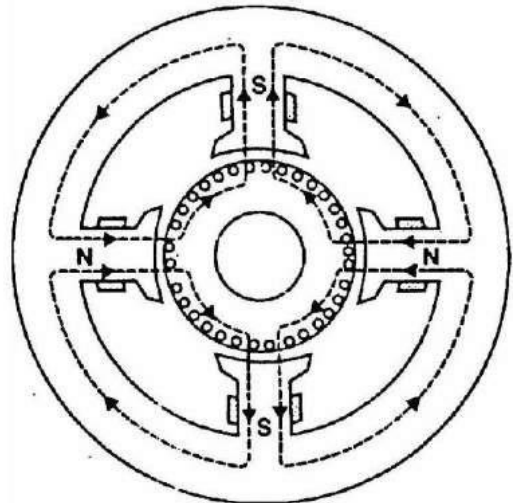

Fig. (1.8)

0 Field system

The function of the field system is to produce uniform magnetic field within which the armature rotates. It consists of a number of salient poles (of course, even number) bolted to the inside of circular frame (generally called yoke). The

yoke is usually made of solid cast steel whereas the pole pieces are composed of stacked laminations. Field coils are mounted on the poles and carry the d.c. exciting current. The field coils are connected in such a way that adjacent poles have opposite polarity.

The m.m.f. developed by the field coils produces a magnetic flux that passes through the pole pieces, the air gap, the armature and the frame (See Fig. 1.8). Practical d.c. machines have air gaps ranging from 0.5 mm to 1.5 mm. Since armature and field systems are composed of materials that have high permeability, most of the m.m.f. of field coils is required to set up flux in the air gap. By reducing the length of air gap, we can reduce the size of field coils (i.e. number of turns).

0 Armature core

The armature core is keyed to the machine shaft and rotates between the field poles. It consists of slotted soft-iron laminations (about 0.4 to 0.6 mm thick) that are stacked to form a cylindrical core as shown in Fig (1.9). The laminations (See Fig. 1.10) are individually coated with a thin insulating film so that they do not come in electrical contact with each other. The purpose of laminating the core is to reduce the eddy current loss. The laminations are slotted to accommodate and provide mechanical security to the armature winding and to give shorter air gap for the flux to cross between the pole face and the armature “teeth”.

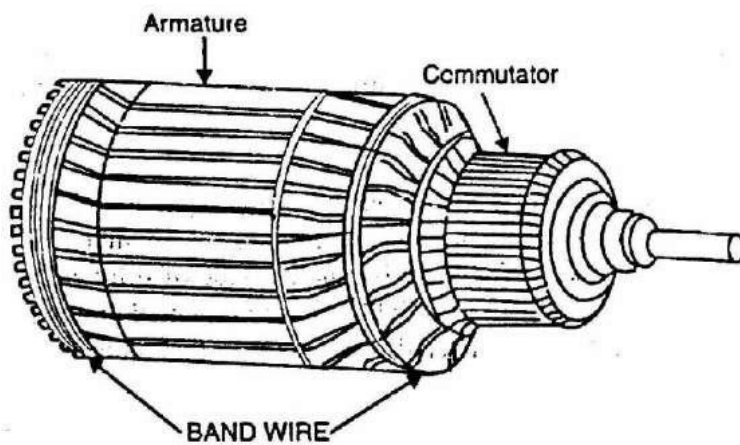

Fig. (1.9)

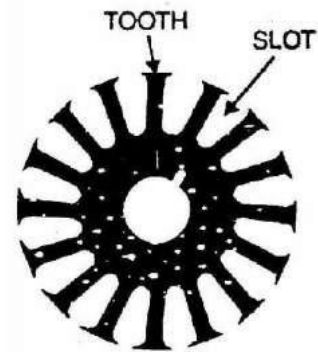

Fig. (1.10)

(iii) Armature winding

The slots of the armature core hold insulated conductors that are connected in a suitable manner. This is known as armature winding. This is the winding in which “working” e.m.f. is induced. The armature conductors are connected in series-parallel; the conductors being connected in series so as to increase the

voltage and in parallel paths so as to increase the current. The armature winding of a d.c. machine is a closed-circuit winding; the conductors being connected in a symmetrical manner forming a closed loop or series of closed loops.

(iv) Commutator

A commutator is a mechanical rectifier which converts the alternating voltage generated in the armature winding into direct voltage across the brushes. The commutator is made of copper segments insulated from each other by mica sheets and mounted on the shaft of the machine (See Fig 1.11). The armature conductors are soldered to the commutator segments in a suitable manner to give rise to the armature winding. Depending upon the manner in which the armature conductors are connected to the commutator segments, there are two types of armature winding in a d.c. machine viz., (a) lap winding (b) wave winding.

Great care is taken in building the commutator because any eccentricity will cause the brushes to bounce, producing unacceptable sparking. The sparks may bum the brushes and overheat and carbonise the commutator.

0 Brushes

The purpose of brushes is to ensure electrical connections between the rotating commutator and stationary external load circuit. The brushes are made of carbon and rest on the commutator. The brush pressure is adjusted by means of adjustable springs (See Fig. 1.12). If the brush pressure is very large, the friction produces heating of the commutator and the brushes. On the other hand, if it is too weak, the imperfect contact with the commutator may produce sparking.

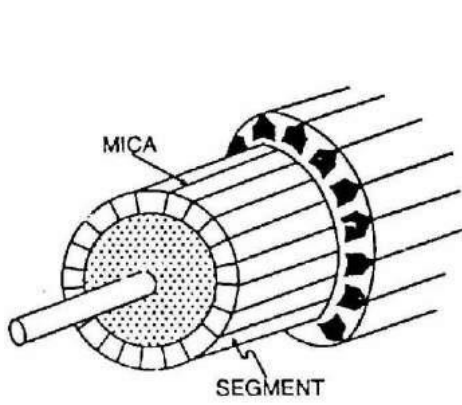

Fig. (1.11)

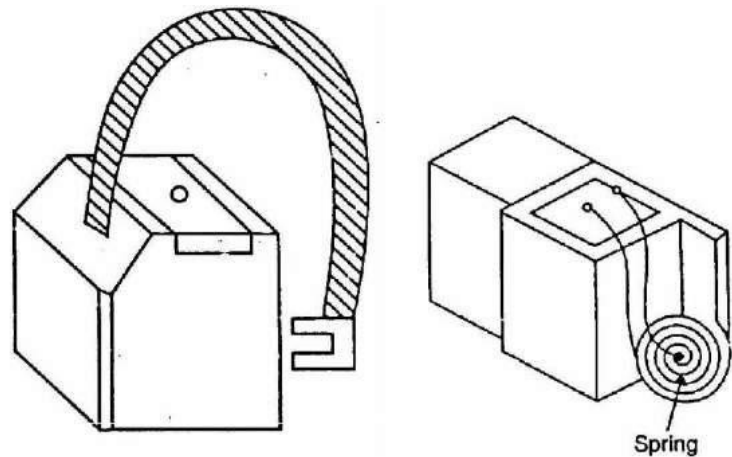

Fig. (1.12)

Multipole machines have as many brushes as they have poles. For example, a 4-pole machine has 4 brushes. As we go round the commutator, the successive brushes have positive and negative polarities. Brushes having the same polarity

are connected together so that we have two terminals viz., the +ve terminal and the -ve terminal.

E.M.F. Equation of a D.C. Generator

We shall now derive an expression for the e.m.f. generated in a d.c. generator.

Let ϕ = flux/pole in Wb
 Z = total number of armature conductors
 P = number of poles
 A = number of parallel paths = 2 ... for wave winding = P
 ... for lap winding
 N = speed of armature in r.p.m.
 E_g = e.m.f. of the generator = e.m.f./parallel path

Flux cut by one conductor in one revolution of the armature,

$$d\phi = P\phi \text{ webers}$$

Time taken to complete one revolution,

$$dt = 60/N \text{ second}$$

$$\begin{aligned} E_g &= \text{e.m.f. per parallel path} \\ &= (\text{e.m.f./conductor}) \times \text{No. of conductors in series per parallel path} \\ &= \frac{P\phi N}{60} \times \frac{Z}{A} \end{aligned}$$

$$\therefore E_g = \frac{P\phi ZN}{60 A}$$

where $A = 2$

for-wave winding

Armature Resistance (R_a)

The resistance offered by the armature circuit is known as armature resistance (R_a) and includes:

- 0 resistance of armature winding
- 1 resistance of brushes

The armature resistance depends upon the construction of machine. Except for small machines, its value is generally less than 1W.

Types of D.C. Generators

The magnetic field in a d.c. generator is normally produced by electromagnets rather than permanent magnets. Generators are generally classified according to their methods of field excitation. On this basis, d.c. generators are divided into the following two classes:

Separately excited d.c. generators

Self-excited d.c. generators

The behaviour of a d.c. generator on load depends upon the method of field excitation adopted.

Separately Excited D.C. Generators

A d.c. generator whose field magnet winding is supplied from an independent external d.c. source (e.g., a battery etc.) is called a separately excited generator. Fig. (1.32) shows the connections of a separately excited generator. The voltage output depends upon the speed of rotation of armature and the field current ($E_g = P\phi ZN/60$ A). The greater the speed and field current, greater is the generated e.m.f. It may be noted that separately excited d.c. generators are rarely used in practice. The d.c. generators are normally of self-excited type.

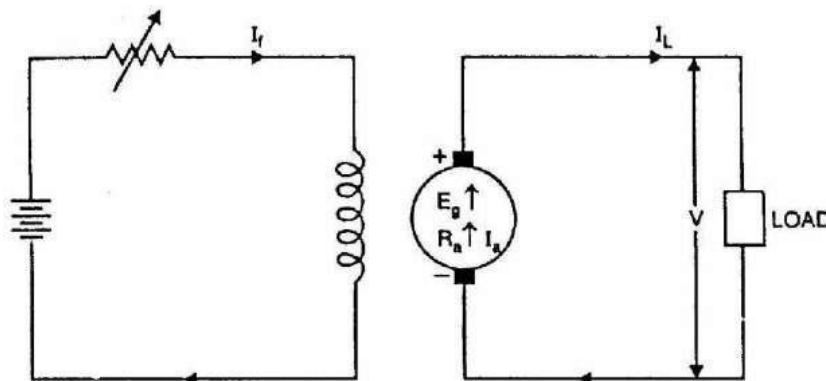

Fig. (1.32)

Armature current, $I_a = I_L$
 Terminal voltage, $V = E_g - I_a R_a$
 Electric power developed = $E_g I_a$
 Power delivered to load = $E_g I_a - I_a^2 R_a = I_a (E_g - I_a R_a) = V I_a$

Self-Excited D.C. Generators

A d.c. generator whose field magnet winding is supplied current from the output of the generator itself is called a self-excited generator. There are three types of self-excited generators depending upon the manner in which the field winding is connected to the armature, namely;

- 0 Series generator;
- 1 Shunt generator;
- 2 Compound generator

0 Series generator

In a series wound generator, the field winding is connected in series with armature winding so that whole armature current flows through the field winding as well as the load. Fig. (1.33) shows the connections of a series wound generator. Since the field winding carries the whole of load current, it has a few turns of thick wire having low resistance. Series generators are rarely used except for special purposes e.g., as boosters.

Armature current, $I_a = I_{se} = I_L = I$ (say)
 Terminal voltage, $V = E_G - I(R_a + R_{se})$
 Power developed in armature = $E_g I_a$

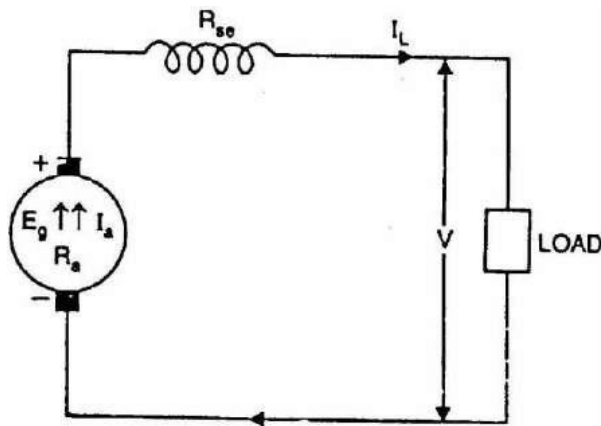

Fig. (1.33)

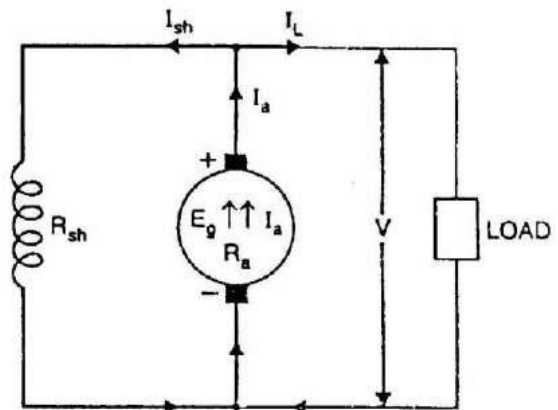

Fig. (1.34)

0 Shunt generator

In a shunt generator, the field winding is connected in parallel with the armature winding so that terminal voltage of the generator is applied across it. The shunt field winding has many turns of fine wire having high resistance. Therefore, only a part of armature current flows through shunt field winding and the rest flows through the load. Fig. (1.34) shows the connections of a shunt-wound generator.

$$\text{Shunt field current, } I_{sh} = V/R_{sh}$$

$$\text{Armature current, } I_a = I_L + I_{sh}$$

$$\text{Terminal voltage, } V = E_g - I_a R_a$$

$$\text{Power developed in armature} = E_g I_a$$

$$\text{Power delivered to load} = V I_L$$

(iii) Compound generator

In a compound-wound generator, there are two sets of field windings on each pole—one is in series and the other in parallel with the armature. A compound wound generator may be:

- 0 Short Shunt in which only shunt field winding is in parallel with the armature winding [See Fig. 1.35 (i)].
- 1 Long Shunt in which shunt field winding is in parallel with both series field and armature winding [See Fig. 1.35 (ii)].

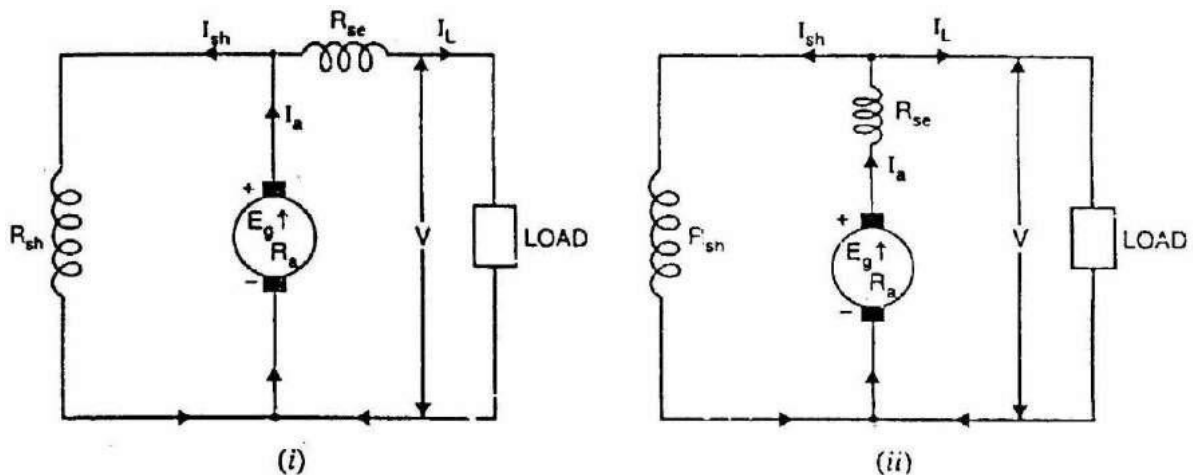

Fig. (1.35)

Short shunt

$$\text{Series field current, } I_{se} = I_L$$

$$\text{Terminal voltage, } V = E_g - I_a R_a -$$

$$I_{se} R_{se}$$

$$\text{Power developed in armature} = E_g I_a$$

$$\text{Power delivered to load} = V I_L$$

Long shunt

$$\begin{aligned} \text{Series field current, } I_{se} &= I_a = I_L + I_{sh} \\ \text{Shunt field current, } I_{sh} &= V/R_{sh} \\ \text{Terminal voltage, } V &= E_g - I_a(R_a + R_{se}) \\ \text{Power developed in armature} &= E_g I_a \\ \text{Power delivered to load} &= V I_L \end{aligned}$$

Brush Contact Drop

It is the voltage drop over the brush contact resistance when current flows. Obviously, its value will depend upon the amount of current flowing and the value of contact resistance. This drop is generally small.

Parallel Operation of D.C. Generators

In a d.c. power plant, power is usually supplied from several generators of small ratings connected in parallel instead of from one large generator. This is due to the following reasons:

(i) Continuity of service

If a single large generator is used in the power plant, then in case of its breakdown, the whole plant will be shut down. However, if power is supplied from a number of small units operating in parallel, then in case of failure of one unit, the continuity of supply can be maintained by other healthy units.

(ii) Efficiency

Generators run most efficiently when loaded to their rated capacity. Electric power costs less per kWh when the generator producing it is efficiently loaded. Therefore, when load demand on power plant decreases, one or more generators can be shut down and the remaining units can be efficiently loaded.

(iii) Maintenance and repair

Generators generally require routine-maintenance and repair. Therefore, if generators are operated in parallel, the routine or emergency operations can be performed by isolating the affected generator while load is being supplied by other units. This leads to both safety and economy.

(iv) Increasing plant capacity

In the modern world of increasing population, the use of electricity is continuously increasing. When added capacity is required, the new unit can be simply paralleled with the old units.

(v) Non-availability of single large unit

In many situations, a single unit of desired large capacity may not be available. In that case a number of smaller units can be operated in parallel to meet the load requirement. Generally a single large unit is more expensive.

Connecting Shunt Generators in Parallel

The generators in a power plant are connected in parallel through bus-bars. The bus-bars are heavy thick copper bars and they act as +ve and -ve terminals. The positive terminals of the generators are connected to the +ve side of bus-bars and negative terminals to the negative side of bus-bars.

Fig. (3.15) shows shunt generator 1 connected to the bus-bars and supplying load. When the load on the power plant increases beyond the capacity of this generator, the second shunt generator 2 is connected in parallel with the first to meet the increased load demand. The procedure for paralleling generator 2 with generator 1 is as under:

512 The prime mover of generator 2 is brought up to the rated speed. Now switch S_4 in the field circuit of the generator 2 is closed.

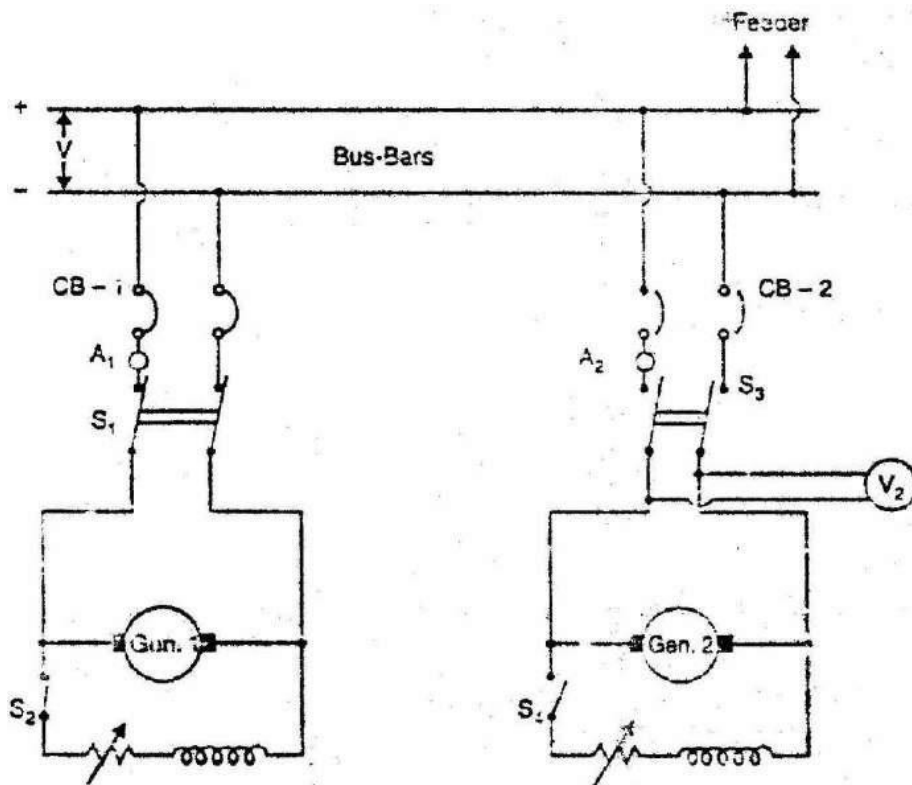

Fig. (3.15)

Next circuit breaker CB-2 is closed and the excitation of generator 2 is adjusted till it generates voltage equal to the bus-bars voltage. This is indicated by voltmeter V_2 .

Now the generator 2 is ready to be paralleled with generator 1. The main switch S_3 , is closed, thus putting generator 2 in parallel with generator 1. Note that generator 2 is not supplying any load because its generated e.m.f. is equal to bus-bars voltage. The generator is said to be “floating” (i.e., not supplying any load) on the bus-bars.

- 0 If generator 2 is to deliver any current, then its generated voltage E should be greater than the bus-bars voltage V . In that case, current supplied by it is $I = (E - V) / R_a$ where R_a is the resistance of the armature circuit. By increasing the field current (and hence induced e.m.f. E), the generator 2 can be made to supply proper amount of load.
- 1 The load may be shifted from one shunt generator to another merely by adjusting the field excitation. Thus if generator 1 is to be shut down, the whole load can be shifted onto generator 2 provided it has the capacity to supply that load. In that case, reduce the current supplied by generator 1 to zero (This will be indicated by ammeter A_1) open C.B.-1 and then open the main switch S_1 .

Compound Generators in Parallel

Under-compounded generators also operate satisfactorily in parallel but over-compounded generators will not operate satisfactorily unless their series fields are paralleled. This is achieved by connecting two negative brushes together as shown in Fig. (3.16) (i). The conductor used to connect these brushes is generally called equalizer bar. Suppose that an attempt is made to operate the two generators in Fig. (3.16) (ii) in parallel without an equalizer bar. If, for any reason, the current supplied by generator 1 increases slightly, the current in its series field will increase and raise the generated voltage. This will cause generator 1 to take more load. Since total load supplied to the system is constant, the current in generator 2 must decrease and as a result its series field is

weakened. Since this effect is cumulative, the generator 1 will take the entire load and drive generator 2 as a motor. Under such conditions, the current in the two machines will be in the direction shown in Fig. (3.16) (ii). After machine 2 changes from a generator to a motor, the current in the shunt field will remain in the same direction, but the current in the armature and series field will reverse. Thus the magnetizing action, of the series field opposes that of the shunt field. As the current taken by the machine 2 increases, the demagnetizing action of series field becomes greater and the resultant field becomes weaker. The resultant field will finally become zero and at that time machine 2 will short-circuit machine 1, opening the breaker of either or both machines.

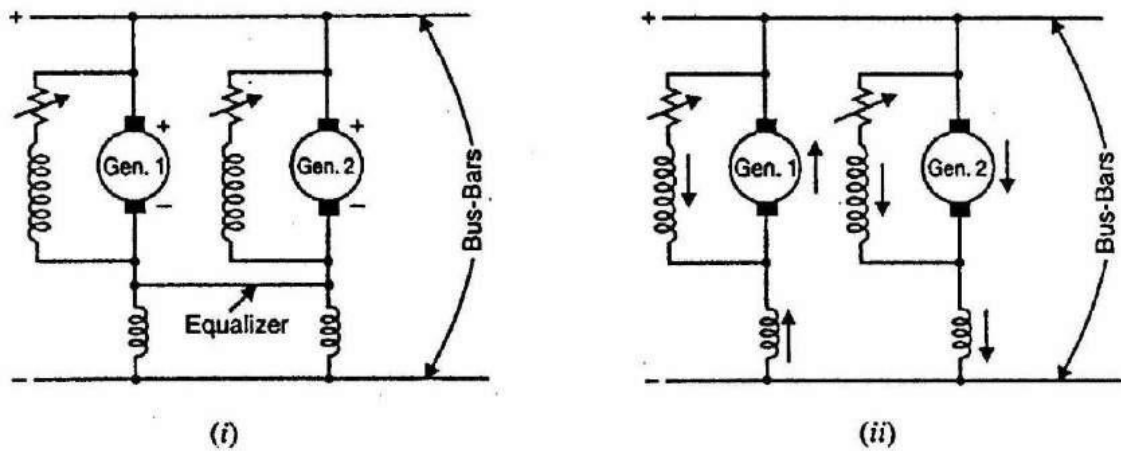

Fig. (3.16)

When the equalizer bar is used, a stabilizing action exist? and neither machine tends to take all the load. To consider this, suppose that current delivered by generator 1 increases [See Fig. 3.16 (i)]. The increased current will not only pass through the series field of generator 1 but also through the equalizer bar and series field of generator 2. Therefore, the voltage of both the machines increases and the generator 2 will take a part of the load.

Chapter (3)

D.C. Motors

Introduction

D. C. motors are seldom used in ordinary applications because all electric supply companies furnish alternating current. However, for special applications such as in steel mills, mines and electric trains, it is advantageous to convert alternating current into direct current in order to use d.c. motors. The reason is that speed/torque characteristics of d.c. motors are much more superior to that of a.c. motors. Therefore, it is not surprising to note that for industrial drives, d.c. motors are as popular as 3-phase induction motors. Like d.c. generators, d.c. motors are also of three types viz., series-wound, shunt-wound and compound-wound. The use of a particular motor depends upon the mechanical load it has to drive.

D.C. Motor Principle

A machine that converts d.c. power into mechanical power is known as a d.c. motor. Its operation is based on the principle that when a current carrying conductor is placed in a magnetic field, the conductor experiences a mechanical force. The direction of this force is given by Fleming's left hand rule and magnitude is given by;

$$F = BIl \text{ newtons}$$

Basically, there is no constructional difference between a d.c. motor and a d.c. generator. The same d.c. machine can be run as a generator or motor.

Working of D.C. Motor

Consider a part of a multipolar d.c. motor as shown in Fig. (4.1). When the terminals of the motor are connected to an external source of d.c. supply:

- 0 the field magnets are excited developing alternate N and S poles;
- 1 the armature conductors carry currents. All conductors under N-pole carry currents in one direction while all the conductors under S-pole carry currents in the opposite direction.

Suppose the conductors under N-pole carry currents into the plane of the paper and those under S-pole carry currents out of the plane of the paper as shown in Fig.(4.1). Since each armature conductor is carrying current and is placed in the

magnetic field, mechanical force acts on it. Referring to Fig. (4.1) and applying Fleming's left hand rule, it is clear that force on each conductor is tending to rotate the armature in anticlockwise direction. All these forces add together to produce a driving torque which sets the armature rotating. When the conductor moves from one side of a

Fig. (4.1)

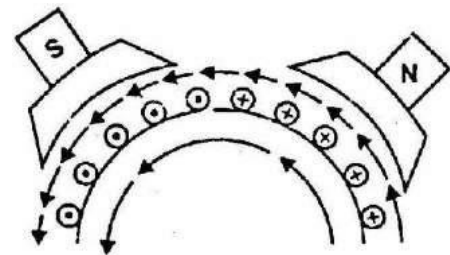
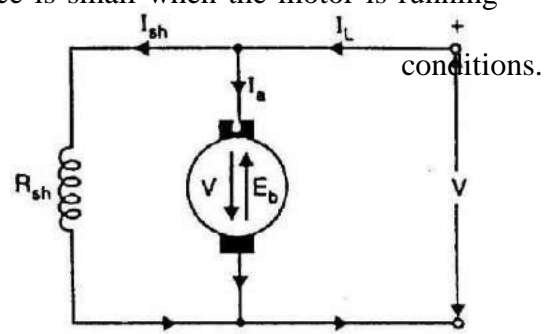

Fig. (4.2)

brush to the other, the current in that conductor is reversed and at the same time it comes under the influence of next pole which is of opposite polarity. Consequently, the direction of force on the conductor remains the same.

Back or Counter E.M.F.

When the armature of a d.c. motor rotates under the influence of the driving torque, the armature conductors move through the magnetic field and hence e.m.f. is induced in them as in a generator. The induced e.m.f. acts in opposite direction to the applied voltage V (Lenz's law) and is known as back or counter e.m.f. E_b . The back e.m.f. $E_b (= P f ZN/60 A)$ is always less than the applied voltage V , although this difference is small when the motor is running under normal



Consider a shunt wound motor shown in Fig. (4.2). When d.c. voltage V is applied across the motor terminals, the field magnets are excited and armature conductors are supplied with current. Therefore, driving torque acts on the armature which begins to rotate. As the armature rotates, back e.m.f. E_b is induced which opposes the applied voltage V . The applied voltage V has to force current through the armature against

the back e.m.f. E_b . The electric work done in overcoming and causing the current to flow against E_b is converted into mechanical energy developed in the armature. It follows, therefore, that energy conversion in a d.c. motor is only possible due to the production of back e.m.f. E_b .

$$\text{Net voltage across armature circuit} = V - E_b$$

If R_a is the armature circuit resistance, then,
$$I_a = \frac{V - E_b}{R_a}$$

Since V and R_a are usually fixed, the value of E_b will determine the current drawn by the motor. If the speed of the motor is high, then back e.m.f. $E_b (= P f$

ZN/60 A) is large and hence the motor will draw less armature current and vice-versa.

Significance of Back E.M.F.

The presence of back e.m.f. makes the d.c. motor a self-regulating machine i.e., it makes the motor to draw as much armature current as is just sufficient to develop the torque required by the load.

$$\text{Armature current, } I_a = \frac{V - E_b}{R_a}$$

- 0 When the motor is running on no load, small torque is required to overcome the friction and windage losses. Therefore, the armature current I_a is small and the back e.m.f. is nearly equal to the applied voltage.
- 1 If the motor is suddenly loaded, the first effect is to cause the armature to slow down. Therefore, the speed at which the armature conductors move through the field is reduced and hence the back e.m.f. E_b falls. The decreased back e.m.f. allows a larger current to flow through the armature and larger current means increased driving torque. Thus, the driving torque increases as the motor slows down. The motor will stop slowing down when the armature current is just sufficient to produce the increased torque required by the load.
- 2 If the load on the motor is decreased, the driving torque is momentarily in excess of the requirement so that armature is accelerated. As the armature speed increases, the back e.m.f. E_b also increases and causes the armature current I_a to decrease. The motor will stop accelerating when the armature current is just sufficient to produce the reduced torque required by the load.

It follows, therefore, that back e.m.f. in a d.c. motor regulates the flow of armature current i.e., it automatically changes the armature current to meet the load requirement.

Voltage Equation of D.C. Motor

Let in a d.c. motor (See Fig.

4.3), V = applied

voltage

E_b = back e.m.f.

R_a = armature resistance

I_a = armature current

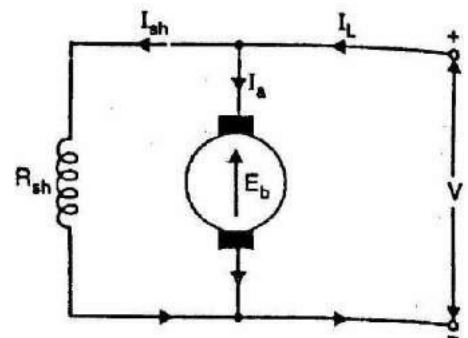

applied voltage V , the net voltage across the armature circuit is $V - E_b$. The armature current I_a is given by;

This is known as voltage equation of the d.c. motor.

Power Equation

If Eq.(i) above is multiplied by I_a throughout, we

$$\text{get, } VI_a = E_b I_a + I_a^2 R_a$$

This is known as power equation of the d.c. motor.

$$\begin{aligned} VI_a &= \text{electric power supplied to armature (armature input)} \\ E_b I_a &= \text{power developed by armature (armature output)} \\ I_a^2 R_a &= \text{electric power wasted in armature (armature Cu loss)} \end{aligned}$$

Thus out of the armature input, a small portion (about 5%) is wasted as $I_a^2 R_a$ and the remaining portion $E_b I_a$ is converted into mechanical power within the armature.

Condition For Maximum Power

The mechanical power developed by the motor is $P_m = E_b I_a$

Since, V and R_a are fixed, power developed by the motor depends upon armature current. For maximum power, dP_m/dI_a should be zero.

$$\therefore \frac{dP_m}{dI_a} = V - 2I_a R_a = 0$$

$$\text{or } I_a R_a = \frac{V}{2}$$

$$\text{Now, } V = E_b + I_a R_a = E_b + \frac{V}{2} \quad \left[\because I_a R_a = \frac{V}{2} \right]$$

$$\therefore E_b = \frac{V}{2}$$

Hence mechanical power developed by the motor is maximum when back e.m.f. is equal to half the applied voltage.

Limitations

In practice, we never aim at achieving maximum power due to the following reasons:

- 0 The armature current under this condition is very large—much excess of rated current of the machine.
- 1 Half of the input power is wasted in the armature circuit. In fact, if we take into account other losses (iron and mechanical), the efficiency will be well below 50%.

Types of D.C. Motors

Like generators, there are three types of d.c. motors characterized by the connections of field winding in relation to the armature viz.:

Shunt-wound motor in which the field winding is connected in parallel with the armature [See Fig. 4.4]. The current through the shunt field winding is not the same as the armature current. Shunt field windings are designed to produce the necessary m.m.f. by means of a relatively large number of turns of wire having high resistance. Therefore, shunt field current is relatively small compared with the armature current.

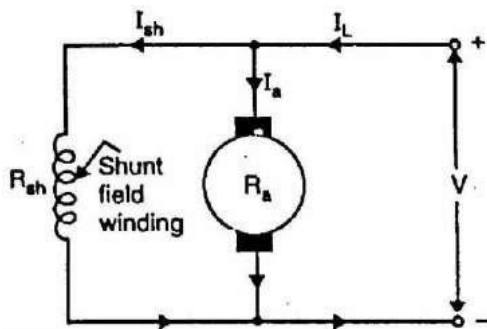

Fig. (4.4)

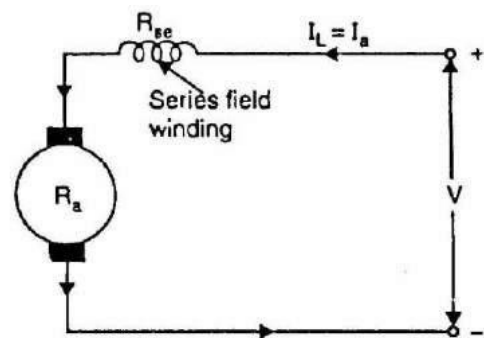

Fig. (4.5)

- 0 **Series-wound motor** in which the field winding is connected in series with the armature [See Fig. 4.5]. Therefore, series field winding carries the armature current. Since the current passing through a series field winding is the same as the armature current, series field windings must be designed with much fewer turns than shunt field windings for the same m.m.f. Therefore, a series field winding has a relatively small number of turns of thick wire and, therefore, will possess a low resistance.
- 1 **Compound-wound motor** which has two field windings; one connected in parallel with the armature and the other in series with it. There are two types of compound motor connections (like generators). When the shunt field winding is directly connected across the armature terminals [See Fig. 4.6], it is called short-shunt connection. When the shunt winding

is

so

connected that it shunts the series combination of armature and series field [See Fig. 4.7], it is called long-shunt connection.

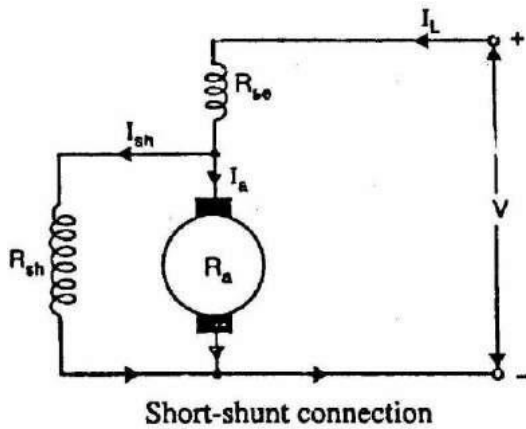

Fig. (4.6)

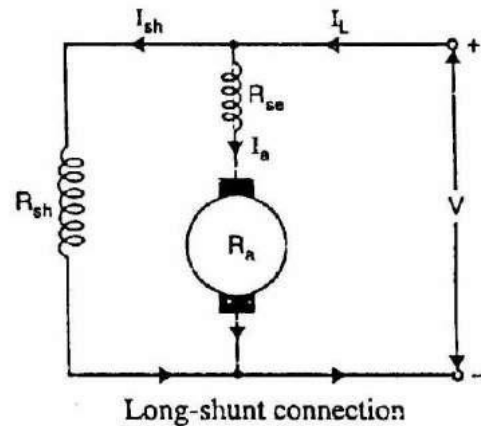

Fig. (4.7)

The compound machines (generators or motors) are always designed so that the flux produced by shunt winding is considerably larger than the flux produced by the series field winding. Therefore, shunt field in compound machines is the basic dominant factor in the production of the magnetic field in the machine.

Armature Torque of D.C. Motor

Torque is the turning moment of a force about an axis and is measured by the product of force (F) and radius (r) at right angle to which the force acts i.e. D.C. Motors 113

$$T = F \cdot r$$

In a d.c. motor, each conductor is acted upon by a circumferential force F at a distance r, the radius of the armature (Fig. 4.8). Therefore, each conductor exerts a torque, tending to rotate the armature. The sum of the torques due to all armature conductors is known as gross or armature torque (T_a).

Let in a d.c. motor

$$= B i l \text{ newtons}$$

r = average radius of armature in m

l = effective length of each conductor in m Z = total number of armature

conductors A = number of parallel paths

i = current in each conductor = I_a/A B = average flux density in Wb/m²

f = flux

per

pole in

Wb P =

number

of poles

Force on each conductor, F

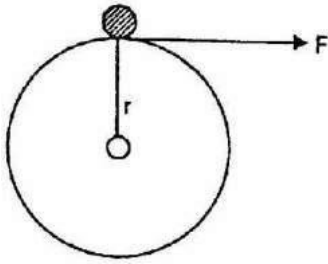

Fig. (4.8)

Torque due to one conductor = $F r$ newton-metre
 Total armature torque, $T = Z F r$
 newton-metre

$$= Z B i r$$

Now $i = \frac{I_a}{A}$, where A is the cross-sectional area or flux path per pole at radius r . Clearly, $A = 2\pi r \ell / P$.

$$T = Z \left(\frac{\phi}{2} \right) \times \left(\frac{I_a}{A} \right) \times \ell \times r$$

$$= Z \times \frac{\phi}{2\pi r \ell / P} \times \frac{I_a}{A} \times \ell \times r = \frac{Z \phi I_a P}{2\pi A} \text{ N-m}$$

or $T = 0.159 Z \phi I_a P / A$ (i)

Since Z, P and A are fixed for a given machine.

$$T_a \propto \phi I_a$$

Hence torque in a d.c. motor is directly proportional to flux per pole and armature current.

(i) For a shunt motor, flux ϕ is practically

constant. $T \propto I_a$

(ii) For a series motor, flux ϕ is directly proportional to armature current I_a , provided magnetic saturation does not take place.

$$T_a \propto I_a^2$$

$$E_b = V - I_a R_a$$

But $E_b = \frac{P}{60} \frac{Z \phi N}{60 A}$

$$\frac{P}{60} \frac{Z \phi N}{60 A}$$

$$\frac{P \phi Z N}{60 A} = V - I_a R_a$$

or
$$\frac{(V - I R_s) 60 A}{p \quad PZ}$$

or
$$N \quad K \quad \frac{(V - I R_s)}{\phi} \quad \text{where} \quad K \quad \frac{60A}{PZ}$$

But $V - I_a R_a = E_a$

$$\therefore N = K \frac{E_b}{\phi}$$

or $N \propto \frac{E_b}{\phi}$

Therefore, in a d.c. motor, speed is directly proportional to back e.m.f. E_b and inversely proportional to flux per pole ϕ .

Speed Relations

(i) For a shunt motor, flux practically remains constant so that $\phi_1 = \phi_2$.

$$\therefore \frac{N_2}{N_1} = \frac{E_{b2}}{E_{b1}}$$

(ii) For a series motor, $\phi \propto I_a$ prior to saturation.

$$\therefore \frac{N_2}{N_1} = \frac{E_{b2}}{E_{b1}} \times \frac{I_{a1}}{I_{a2}}$$

where I_{a1} = initial armature current
 I_{a2} = final armature current

Efficiency of a D.C. Motor

Like a d.c. generator, the efficiency of a d.c. motor is the ratio of output power to the input power i.e.

$$\text{Efficiency} = \frac{\text{output}}{\text{input} + \text{output} + \text{losses}} \times 100 = \frac{\text{output}}{\text{output} + \text{losses}} \times 100$$

As for a generator (See Sec. 1.29), the efficiency of a d.c. motor will be maximum when:

$$\text{Variable losses} = \text{Constant losses}$$

Therefore, the efficiency curve of a d.c. motor is similar in shape to that of a d.c. generator.

Power Stages

The power stages in a d.c. motor are represented diagrammatically in Fig. (4.12).

A - B = Copper losses

B - C = Iron and friction losses

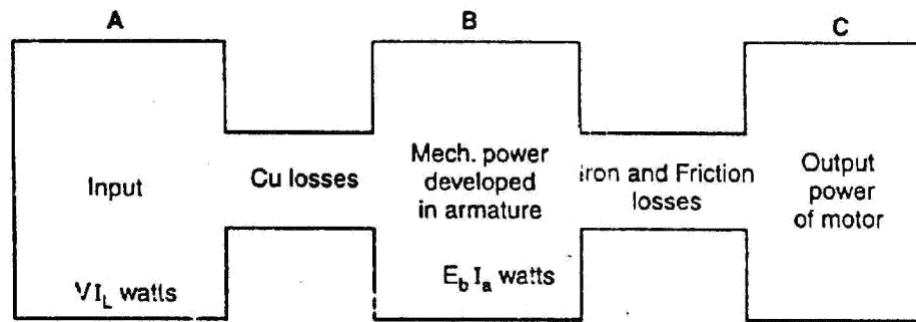

Fig. (4.12)

Overall efficiency, $\eta_c = C/A$
 Electrical efficiency, $\eta_e = B/A$
 Mechanical efficiency, $\eta_m = C/B$

D.C. Motor Characteristics

There are three principal types of d.c. motors viz., shunt motors, series motors and compound motors. Both shunt and series types have only one field winding wound on the core of each pole of the motor. The compound type has two separate field windings wound on the core of each pole. The performance of a d.c. motor can be judged from its characteristic curves known as motor characteristics, following are the three important characteristics of a d.c. motor:

(i) **Torque and Armature current characteristic (T_a/I_a)**

It is the curve between armature torque T_a and armature current I_a of a d.c. motor. It is also known as electrical characteristic of the motor.

(ii) **Speed and armature current characteristic (N/i_a)**

It is the curve between speed N and armature current I_a of a d.c. motor. It is very important characteristic as it is often the deciding factor in the selection of the motor for a particular application.

(iii) **Speed and torque characteristic (N/T_a)**

It is the curve between speed N and armature torque T_a of a d.c. motor. It is also known as mechanical characteristic.

Characteristics of Shunt Motors

Fig. (4.13) shows the connections of a d.c. shunt motor. The field current I_{sh} is constant since the field winding is directly connected to the supply voltage V which is assumed to be constant. Hence, the flux in a shunt motor is approximately constant.

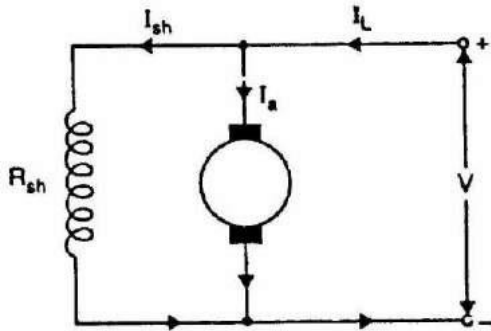

Fig. (4.13)

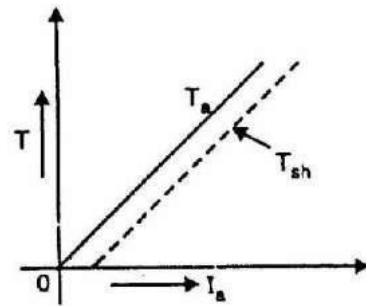

Fig. (4.14)

0 **T_a/I_a Characteristic.** We know that in a d.c. motor, $T_a \propto f I_a$

Since the motor is operating from a constant supply voltage, flux f is constant (neglecting armature reaction).

$$T_a \propto I_a$$

Hence T_a/I_a characteristic is a straight line passing through the origin as shown in Fig. (4.14). The shaft torque (T_{sh}) is less than T_a and is shown by a dotted line. It is clear from the curve that a very large current is required to start a heavy load. Therefore, a shunt motor should not be started on heavy load.

(ii) **N/I_a Characteristic.** The speed N of a d.c. motor is given by; $N \propto \frac{E_b}{f}$
 The flux f and back e.m.f. E_b in a shunt motor are almost constant under normal conditions. Therefore, speed of a shunt motor will remain constant as the armature current varies (dotted line AB in Fig. 4.15). Strictly speaking, when load is increased, E_b ($= V - I_a R_a$) and f decrease due to the armature resistance drop and armature reaction respectively. However, E_b decreases slightly more than f so that the speed of the motor decreases slightly with load (line AC).

0 **N/T_a Characteristic.** The curve is obtained by plotting the values of N and T_a for various armature currents (See Fig. 4.16). It may be seen that speed falls somewhat as the load torque increases.

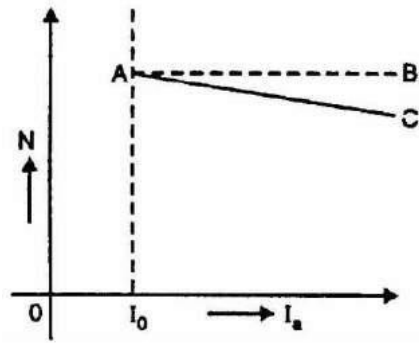

Fig. (4.15)

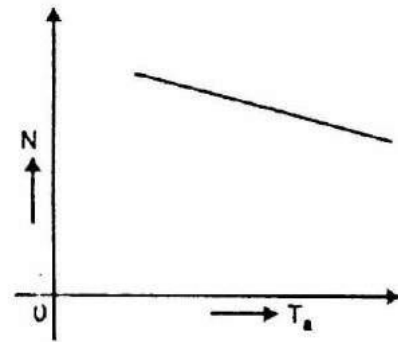

Fig. (4.16)

Conclusions

Following two important conclusions are drawn from the above characteristics:

- 0 There is slight change in the speed of a shunt motor from no-load to full-load. Hence, it is essentially a constant-speed motor.
- 1 The starting torque is not high because $T_a \propto I_a$.

Characteristics of Series Motors

Fig. (4.17) shows the connections of a series motor. Note that current passing through the field winding is the same as that in the armature. If the mechanical load on the motor increases, the armature current also increases. Hence, the flux in a series motor increases with the increase in armature current and vice-versa.

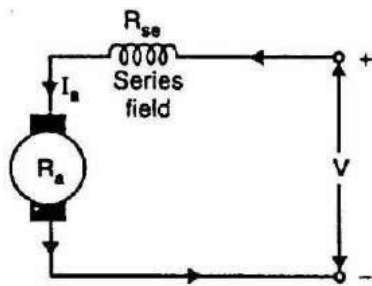

Fig. (4.17)

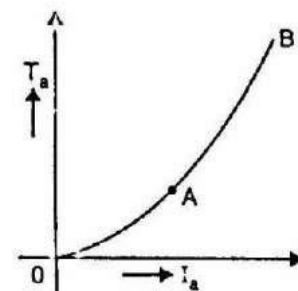

Fig. (4.18)

0 **T_a/I_a Characteristic.** We know that:

$$T_a \propto f I_a$$

Upto magnetic saturation, $f \propto I_a$ so that $T_a \propto I_a^2$. After magnetic saturation, f is constant so that $T_a \propto I_a$.

Thus upto magnetic saturation, the armature torque is directly proportional to the square of armature current. If I_a is doubled, T_a is almost quadrupled.

Therefore, T_a/I_a curve upto magnetic saturation is a parabola (portion OA of the curve in Fig. 4.18). However, after magnetic saturation, torque is directly proportional to the armature current. Therefore, T_a/I_a curve after magnetic saturation is a straight line (portion AB of the curve).

It may be seen that in the initial portion of the curve (i.e. upto magnetic saturation), $T_a \propto I_a^2$. This means that starting torque of a d.c. series motor will be very high as compared to a shunt motor (where that $T_a \propto I_a$).

Thus, upto magnetic saturation, the N/I_a curve follows the hyperbolic path as shown in Fig. (4.19). After saturation, the flux becomes constant and so does the speed.

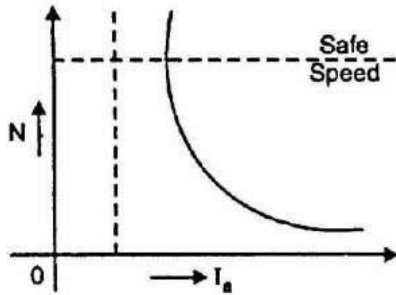

Fig. (4.19)

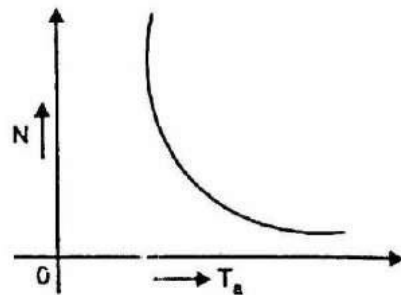

Fig. (4.20)

N/T_a Characteristic. The N/T_a characteristic of a series motor is shown in Fig. (4.20). It is clear that series motor develops high torque at low speed and vice-versa. It is because an increase in torque requires an increase in armature current, which is also the field current. The result is that flux is strengthened and hence the speed drops ($N \propto 1/\phi$). Reverse happens should the torque be low.

Conclusions

Following three important conclusions are drawn from the above characteristics of series motors:

- 0 It has a high starting torque because initially $T_a \propto I_a^2$.
- 1 It is a variable speed motor (See N/I_a curve in Fig. 4.19) i.e., it automatically adjusts the speed as the load changes. Thus if the load decreases, its speed is automatically raised and vice-versa.
- 2 At no-load, the armature current is very small and so is the flux. Hence, the speed rises to an excessive high value ($\propto 1/\phi$). This is dangerous for the machine which may be destroyed due to centrifugal forces set up in the rotating parts. Therefore, a series motor should never be started on no-load. However, to start a series motor, mechanical load is first put and then the motor is started.

Note. The minimum load on a d.c. series motor should be great enough to keep the speed within limits. If the speed becomes dangerously high, then motor must be disconnected from the supply.

Compound Motors

A compound motor has both series field and shunt field. The shunt field is always stronger than the series field. Compound motors are of two types:

- 0 *Cumulative-compound motors* in which series field aids the shunt field.
- 1 *Differential-compound motors* in which series field opposes the shunt field.

Differential compound motors are rarely used due to their poor torque characteristics at heavy loads.

Characteristics of Cumulative Compound Motors

Fig. (4.21) shows the connections of a cumulative-compound motor. Each pole carries a series as well as shunt field winding; the series field aiding the shunt field.

- 0 **T_a/I_a Characteristic.** As the load increases, the series field increases but shunt field strength remains constant. Consequently, total flux is increased and hence the armature torque ($\propto T_a \propto \phi I_a$). It may be noted that torque of a cumulative-compound motor is greater than that of shunt motor for a given armature current due to series field [See Fig. 4.22].

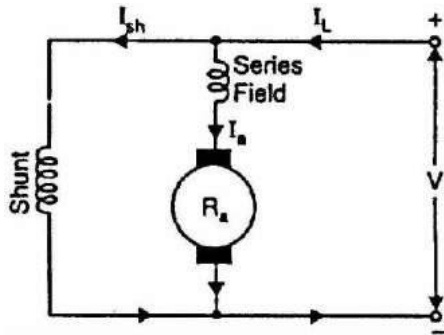

Fig. (4.21)

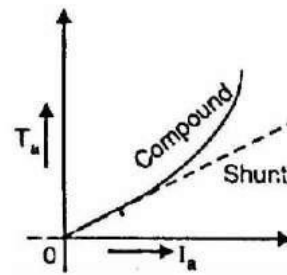

Fig. (4.22)

0 N/I_a Characteristic. As explained above, as the load increases, the flux per pole also increases. Consequently, the speed ($N \propto 1/\phi$) of the motor falls as the load increases (See Fig. 4.23). It may be noted that as the load is added, the increased amount of flux causes the speed to decrease more than does the speed of a shunt motor. Thus the speed regulation of a cumulative compound motor is poorer than that of a shunt motor.

Note: Due to shunt field, the motor has a definite no load speed and can be operated safely at no-load.

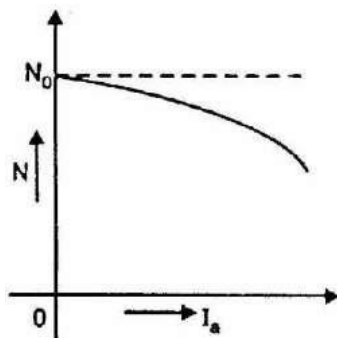

Fig. (4.23)

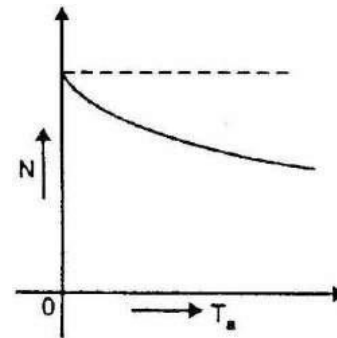

Fig. (4.24)

0 N/T_a Characteristic. Fig. (4.24) shows N/T_a characteristic of a cumulative compound motor. For a given armature current, the torque of a cumulative compound motor is more than that of a shunt motor but less than that of a series motor.

Conclusions

A cumulative compound motor has characteristics intermediate between series and shunt motors.

- 0 Due to the presence of shunt field, the motor is prevented from running away at no-load.
- 1 Due to the presence of series field, the starting torque is increased.

Comparison of Three Types of Motors

0 The speed regulation of a shunt motor is better than that of a series motor.

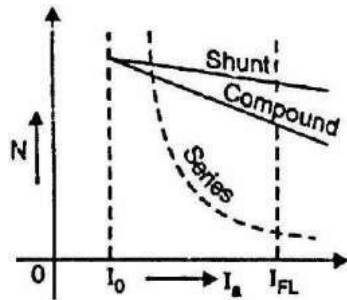

Fig. (4.25)

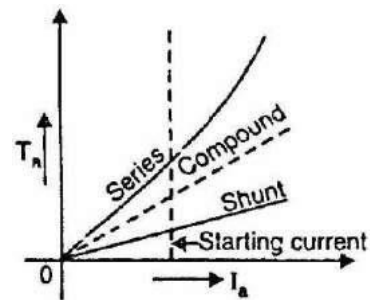

Fig. (4.26)

However, speed regulation of a cumulative compound motor lies between shunt and series motors (See Fig. 4.25).

0 For a given armature current, the starting torque of a series motor is more than that of a shunt motor. However, the starting torque of a cumulative compound motor lies between series and shunt motors (See Fig. 4.26).

1 Both shunt and cumulative compound motors have definite no-load speed. However, a series motor has dangerously high speed at no-load.

Applications of D.C. Motors

0 Shunt motors

The characteristics of a shunt motor reveal that it is an approximately constant speed motor. It is, therefore, used

- 0 where the speed is required to remain almost constant from no-load to full-load
- 1 where the load has to be driven at a number of speeds and any one of which is required to remain nearly constant

Industrial use: Lathes, drills, boring mills, shapers, spinning and weaving machines etc.

0 Series motors

It is a variable speed motor i.e., speed is low at high torque and vice-versa.

However, at light or no-load, the motor tends to attain dangerously high speed.

The motor has a high starting torque. It is, therefore, used

- 0 where large starting torque is required e.g., in elevators and electric traction

0 where the load is subjected to heavy fluctuations and the speed is automatically required to reduce at high torques and vice-versa

Industrial use: Electric traction, cranes, elevators, air compressors, vacuum cleaners, hair drier, sewing machines etc.

0 Compound motors

Differential-compound motors are rarely used because of their poor torque characteristics. However, cumulative-compound motors are used where a fairly constant speed is required with irregular loads or suddenly applied heavy loads.

Industrial use: Presses, shears, reciprocating machines etc.

4.28 Troubles in D.C. Motors

Several troubles may arise in a d.c. motor and a few of them are discussed below:

0 Failure to start

This may be due to (i) ground fault (ii) open or short-circuit fault (iii) wrong connections (iv) too low supply voltage (v) frozen bearing or (vi) excessive load.

0 Sparking at brushes

This may be due to (i) troubles in brushes (ii) troubles in commutator (iii) troubles in armature or (iv) excessive load.

- 0 Brush troubles may arise due to insufficient contact surface, too short a brush, too little spring tension or wrong brush setting.
- 1 Commutator troubles may be due to dirt on the commutator, high mica, rough surface or eccentricity.
- 2 Armature troubles may be due to an open armature coil. An open armature coil will cause sparking each time the open coil passes the brush. The location of this open coil is noticeable by a burnt line between segments connecting the coil.

0 Vibrations and pounding noises

These maybe due to (i) worn bearings (ii) loose parts (iii) rotating parts hitting stationary parts (iv) armature unbalanced (v) misalignment of machine (vi) loose coupling etc.

0 Overheating

The overheating of motor may be due to (i) overloads (ii) sparking at the brushes (iii) short-circuited armature or field coils (iv) too frequent starts or reversals (v) poor ventilation (vi) incorrect voltage.

Speed Control of D.C. Motors

The speed of a d.c. motor is given by:

The speed of a d.c. motor is given by:

$$N \propto \frac{E_b}{\phi}$$

or
$$N = K \frac{(V - I_a R)}{\phi} \text{ r.p.m.}$$

where
$$R = R_a \quad \text{for shunt motor}$$

$$= R_a + R_{se} \quad \text{for series motor}$$

From exp. (i), it is clear that there are three main methods of controlling the speed of a d.c. motor, namely:

- 0 By varying the flux per pole (ϕ). This is known as flux control method.
- 1 By varying the resistance in the armature circuit. This is known as armature control method.
- 2 By varying the applied voltage V . This is known as voltage control method.

Speed Control of D.C. Shunt Motors

The speed of a shunt motor can be changed by (i) flux control method

0 armature control method (iii) voltage control method. The first method (i.e. flux control method) is frequently used because it is simple and inexpensive.

0 Flux control method

It is based on the fact that by varying the flux ϕ , the motor speed ($N \propto 1/\phi$) can be changed and hence the name flux control method. In this method, a variable resistance (known as shunt field rheostat) is placed in series with shunt field winding as shown in Fig. (5.1).

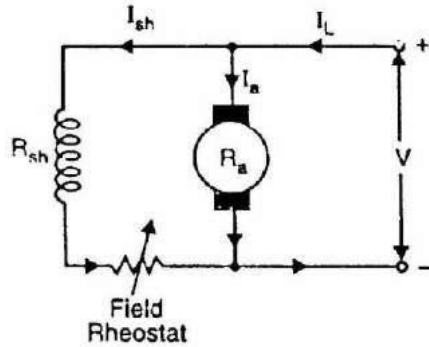

Fig. (5.1)

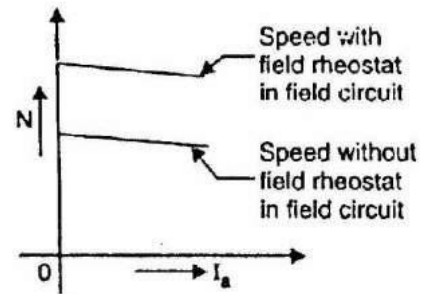

Fig. (5.2)

The shunt field rheostat reduces the shunt field current I_{sh} and hence the flux ϕ . Therefore, we can only raise the speed of the motor above the normal speed (See Fig. 5.2). Generally, this method permits to increase the speed in the ratio 3:1. Wider speed ranges tend to produce instability and poor commutation.

Advantages

- 0 This is an easy and convenient method.
- 1 It is an inexpensive method since very little power is wasted in the shunt field rheostat due to relatively small value of I_{sh} .
- 2 The speed control exercised by this method is independent of load on the machine.

Disadvantages

- 0 Only speeds higher than the normal speed can be obtained since the total field circuit resistance cannot be reduced below R_{sh} —the shunt field winding resistance.
- 1 There is a limit to the maximum speed obtainable by this method. It is because if the flux is too much weakened, commutation becomes poorer.

Note. The field of a shunt motor in operation should never be opened because its speed will increase to an extremely high value.

0 Armature control method

This method is based on the fact that by varying the voltage available across the armature, the back e.m.f and hence the speed of the motor can be changed. This

is done by inserting a variable resistance R_C (known as controller resistance) in series with the armature as shown in Fig. (5.3).

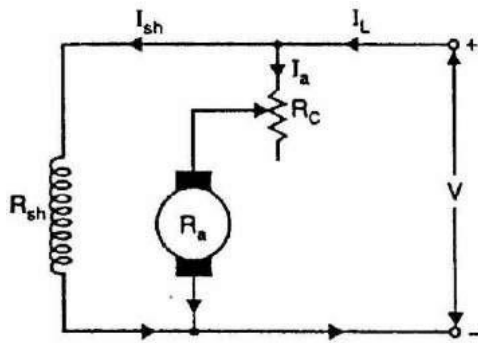

Fig. (5.3)

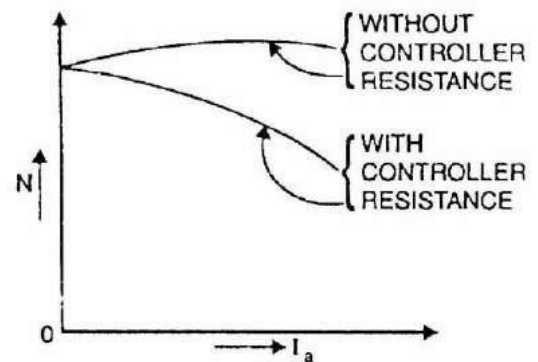

Fig. (5.4)

$$N \propto V - I_a (R_a + R_C)$$

where $R_C =$ controller resistance

Due to voltage drop in the controller resistance, the back e.m.f. (E_b) is decreased. Since $N \propto E_b$, the speed of the motor is reduced. The highest speed obtainable is that corresponding to $R_C = 0$ i.e., normal speed. Hence, this method can only provide speeds below the normal speed (See Fig. 5.4).

Disadvantages

- 0 A large amount of power is wasted in the controller resistance since it carries full armature current I_a .
- 1 The speed varies widely with load since the speed depends upon the voltage drop in the controller resistance and hence on the armature current demanded by the load.
- 2 The output and efficiency of the motor are reduced.
- 3 This method results in poor speed regulation.

Due to above disadvantages, this method is seldom used to control the speed of shunt motors.

Note. The armature control method is a very common method for the speed control of d.c. series motors. The disadvantage of poor speed regulation is not important in a series motor which is used only where varying speed service is required.

Necessity of D.C. Motor Starter

At starting, when the motor is stationary, there is no back e.m.f. in the armature. Consequently, if the motor is directly switched on to the mains, the armature will draw a heavy current ($I_a = V/R_a$) because of small armature resistance. As an example, 5 H.P., 220 V shunt motor has a full-load current of 20 A and an armature resistance of about 0.5 Ω . If this motor is directly switched on to supply, it would take an armature current of $220/0.5 = 440$ A which is 22 times the full-load current. This high starting current may result in:

- 0 burning of armature due to excessive heating effect,
- 1 damaging the commutator and brushes due to heavy sparking,

- 2 excessive voltage drop in the line to which the motor is connected. The result is that the operation of other appliances connected to the line may be impaired and in particular cases, they may refuse to work.

In order to avoid excessive current at starting, a variable resistance (known as starting resistance) is inserted in series with the armature circuit. This resistance is gradually reduced as the motor gains speed (and hence E_b increases) and eventually it is cut out completely when the motor has attained full speed. The value of starting resistance is generally such that starting current is limited to 1.25 to 2 times the full-load current.

Types of D.C. Motor Starters

The starting operation of a d.c. motor consists in the insertion of external resistance into the armature circuit to limit the starting current taken by the motor and the removal of this resistance in steps as the motor accelerates. When

the motor attains the normal speed, this resistance is totally cut out of the armature circuit. It is very important and desirable to provide the starter with protective devices to enable the starter arm to return to OFF position

- 0 when the supply fails, thus preventing the armature being directly across the mains when this voltage is restored. For this purpose, we use no-volt release coil.
- 1 when the motor becomes overloaded or develops a fault causing the motor to take an excessive current. For this purpose, we use overload release coil.

There are two principal types of d.c. motor starters viz., three-point starter and four-point starter. As we shall see, the two types of starters differ only in the manner in which the no-volt release coil is connected.

Three-Point Starter

This type of starter is widely used for starting shunt and compound motors.

Schematic diagram

Fig. (5.16) shows the schematic diagram of a three-point starter for a shunt motor with protective devices. It is so called because it has three terminals L, Z and A. The starter consists of starting resistance divided into several sections and connected in series with the armature. The tapping points of the starting resistance are brought out to a number of studs. The three terminals L, Z and A of the starter are connected respectively to the positive line terminal, shunt field terminal and armature terminal. The other terminals of the armature and shunt field windings are connected to the negative terminal of the supply. The no-volt release coil is connected in the shunt field circuit. One end of the handle is connected to the terminal L through the over-load release coil. The other end of the handle moves against a spiral spring and makes contact with each stud during starting operation, cutting out more and more starting resistance as it passes over each stud in clockwise direction.

Operation

- 0 To start with, the d.c. supply is switched on with handle in the OFF position.
- 1 The handle is now moved clockwise to the first stud. As soon as it comes in contact with the first stud, the shunt field winding is directly connected across the supply, while the whole starting resistance is inserted in series with the armature circuit.
- 2 As the handle is gradually moved over to the final stud, the starting resistance is cut out of the armature circuit in steps. The handle is now held

magnetically by the no-volt release coil which is energized by shunt field current.

- 0 If the supply voltage is suddenly interrupted or if the field excitation is accidentally cut, the no-volt release coil is demagnetized and the handle goes back to the OFF position under the pull of the spring. If no-volt release coil were not used, then in case of failure of supply, the handle would remain on the final stud. If then supply is restored, the motor will be directly connected across the supply, resulting in an excessive armature current.
- 1 If the motor is over-loaded (or a fault occurs), it will draw excessive current from the supply. This current will increase the ampere-turns of the over-load release coil and pull the armature C, thus short-circuiting the no-volt release coil. The no-volt coil is demagnetized and the handle is pulled to the OFF position by the spring. Thus, the motor is automatically disconnected from the supply.

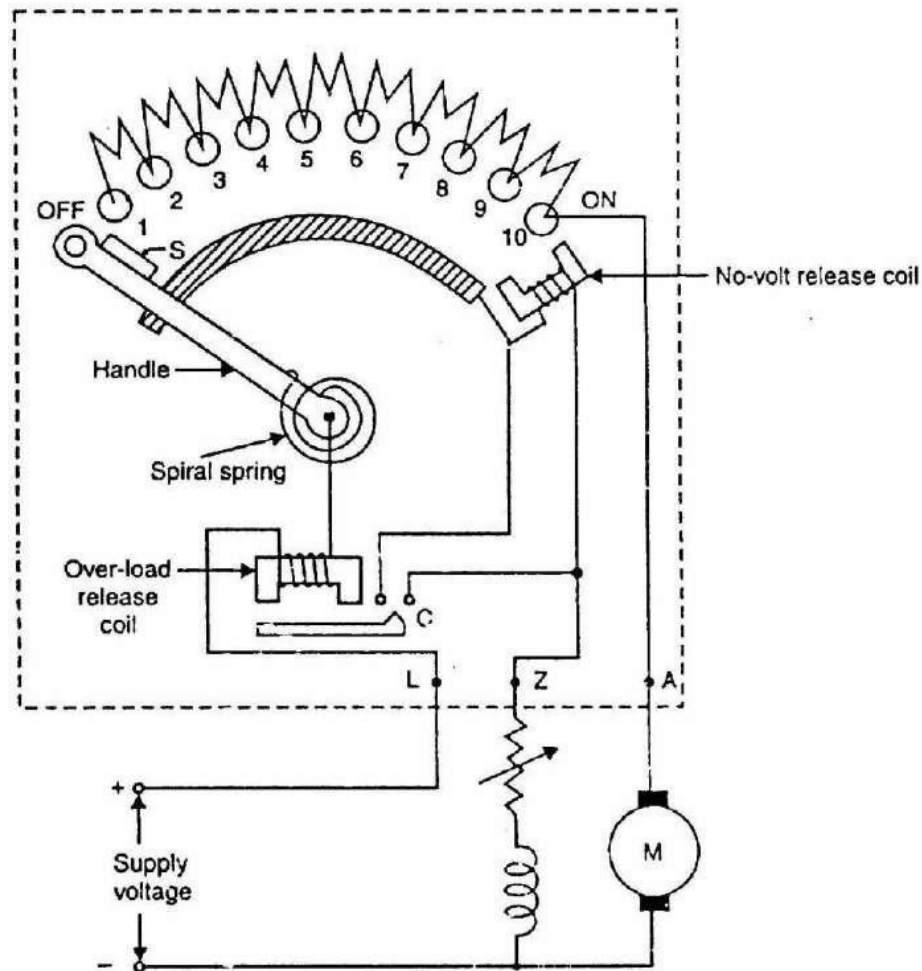

Fig. (5.16)

Drawback

In a three-point starter, the no-volt release coil is connected in series with the shunt field circuit so that it carries the shunt field current. While exercising speed control through field regulator, the field current may be weakened to such an extent that the no-volt release coil may not be able to keep the starter arm in the ON position. This may disconnect the motor from the supply when it is not desired. This drawback is overcome in the four-point starter.

5.10 Four-Point Starter

In a four-point starter, the no-volt release coil is connected directly across the supply line through a protective resistance R. Fig. (5.17) shows the schematic diagram of a 4-point starter for a shunt motor (over-load release coil omitted for clarity of the figure). Now the no-volt release coil circuit is independent of the shunt field circuit. Therefore, proper speed control can be exercised without affecting the operation of no-volt release coil.

Note that the only difference between a three-point starter and a four-point starter is the manner in which no-volt release coil is connected. However, the working of the two starters is the same. It may be noted that the three-point starter also provides protection against an open-field circuit. This protection is not provided by the four-point starter.

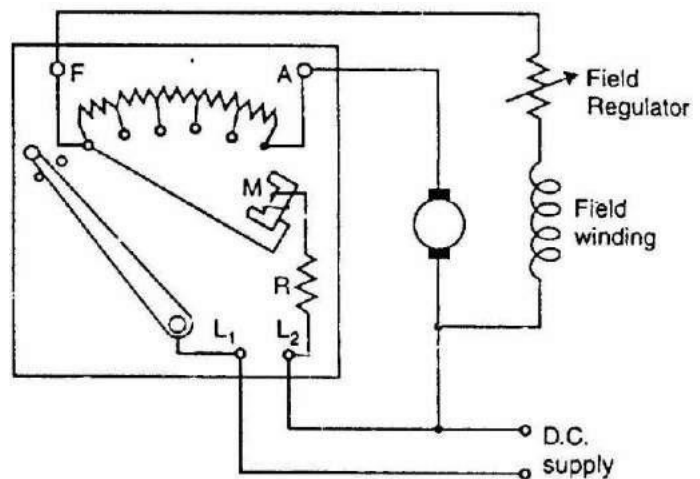

Fig. (5.17)

Grading of Starting Resistance—Shunt Motors

For starting the motor satisfactorily, the starting resistance is divided into a number of sections in such a way that current fluctuates between maximum (I_m) and minimum (I) values. The upper limit is that value established as the maximum permissible for the motor; it is generally 1.5 times the full-load current of the motor. The lower limit is the value set as a minimum for starting operation; it may be equal to full-load current of the motor or some predetermined value. Fig. (5.18) shows shunt-wound motor with starting resistance divided into three sections between four studs. The resistances of

these sections should be so selected that current during starting remains between I_m and I as shown in Fig. (5.19).

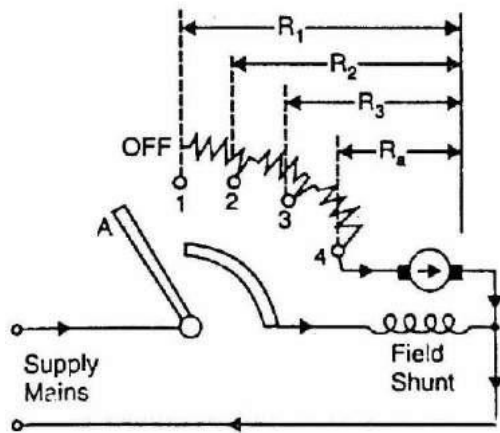

Fig. (5.18)

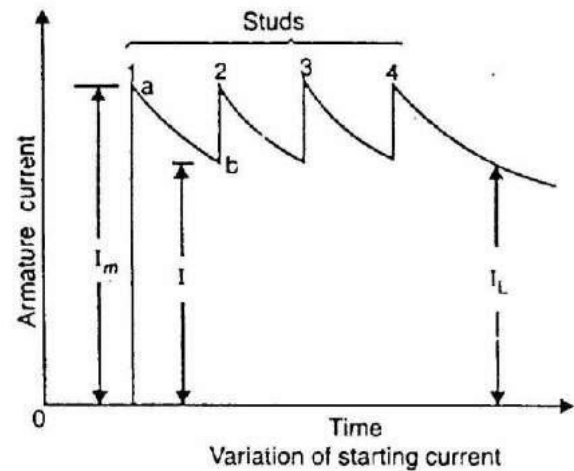

Fig. (5.19)

- 0 When arm A is moved from OFF position to stud 1, field and armature circuits are energized and whole of the starting resistance is in series with the armature. The armature current jumps to maximum value given by;

$$I_m = \frac{V}{R_1}$$

$$I_m = \frac{V}{R_1}$$

where $R_1 =$ Resistance of starter and armature

- 0 As the armature accelerates, the generated e.m.f. increases and the armature current decreases as indicated by curve ab. When the current has fallen to I , arm A is moved over to stud 2, cutting out sufficient resistance to allow the current to rise to I_m again. This operation is repeated until the arm A is on stud 4 and the whole of the starting resistance is cut out of the armature circuit.
- 1 Now the motor continues to accelerate and the current decreases until it settles down at some value I_L such that torque due to this current is just sufficient to meet the load requirement.

Chapter (4)

AC CIRCUITS

5.22 COMPLEX NUMBERS

A complex number A is written in the form $A = a + jb$

where a and b are real numbers and the symbol j is used to denote $\sqrt{-1}$. The symbol j is the unit imaginary number, or imaginary operator. We call a as the real part of A . It is noted by the symbol $\text{Re}[A]$ so that $\text{Re}[A] = a$

The number b is called the imaginary part of the complex number A . It is denoted by the symbol

$$\text{Im}[A] = b$$

It is to be noted that the imaginary part of a complex number is a real number, but j times the imaginary part is an imaginary number. Thus, jb is an imaginary number. The imaginary part of A is b and not jb . It is also to be noted that the real number is a special case of a complex number. A real number is a complex number with its imaginary part equal to zero. For example, real number 5 is equal to $(5 + j0)$. Similarly, an imaginary number is a special case of complex number with its real part equal to zero. For example, the imaginary number $j3$ is equal to $(0 + j3)$.

Since $j = \sqrt{-1}$

$$j^2 = j \cdot j = -1$$

$$j^3 = j^2 \cdot j = -j$$

$$j^4 = j^2 \cdot j^2 = (-1) \times (-1) = 1$$

$$\frac{1}{j} = \frac{j}{jj} = \frac{j}{-1} = -j$$

In electrical engineering, the symbol j is used for $\sqrt{-1}$ rather than i as is the norm in mathematics. This is because of the use of the symbol i for current in electrical engineering.

Complex Plane

Since $A = a + jb$ depends upon two numbers a and b , we may represent each complex number as a point in a 2-dimensional plane. This is done by plotting the real number on the horizontal axis and the imaginary number on the vertical axis.

The horizontal axis Ox is called the *real axis* or *reference axis*. It is the axis of real

We know that $P = VI \cos \phi$, $Q = VI \sin \phi$

We shall define complex power S as $S = P + jQ$

P , Q and S are shown in Fig. 5.47.

The right angled triangle OAB formed by P , Q and S is called the power triangle. It is to be noted the phase angle ϕ of the impedance $Z = Z$

$$\tan \phi = \frac{Q}{P} = \frac{S \sin \phi}{S \cos \phi} = \frac{P \tan \phi}{P} \implies \tan \phi = \frac{Q}{P}$$

$$\text{and } S^2 = P^2 + Q^2$$

flit s 4. ...



$$S = P + jQ = S \cos \phi + jS \sin \phi = VI \cos \phi + jVI \sin \phi = VI(\cos \phi + j \sin \phi) \quad \dots (iii)$$

$$\therefore S = VIe^{j\phi} = VI \angle \phi$$

$$\text{Since } I = I \angle \theta, I^* = I \angle -\theta, VI^* = (VI \angle \theta + \phi)(I \angle -\theta)$$

$$VI^* = VI \angle \phi \dots (vi)$$

$$\text{Thus } S = P + jQ = VI^*, P = \text{Re}[VI^*] = VI \cos \phi = I^2 R \quad \dots (vii)$$

$$Q = \text{Im}[VI^*] = VI \sin \phi = I^2 X$$

Equation (vi) shows that active power P can be obtained by taking the real part of the product of the complex expression of the voltage and the conjugate of current. Equation (vii) shows that reactive power Q can be obtained by taking the imaginary part of the product of the complex expression of the voltage and the complex expression of the conjugate of current.

example, if $V = a + jb$, $I = c + jd$, then $I^* = c - jd$, $S = VI^*$
 $= (a + jb)(c - jd) = (ac + bd) + j(bc - ad) = P + jQ$

$$Q = \text{Im}[VI^*] = (bc - ad) \quad \dots (ix)$$

Step-by-step calculation p

vars (ix)

0"é *°."

series AC circuits.
Express R in ohms, L in henrys, C in farads and f in hertz

4. Determine the impedance in rectangular form by the formula $Z = R + j(X_L - X_C) \Omega$

s Determine the impedance in rectangular form also by the formula $Z = R + j(X_L - X_C) \Omega$

$$\text{where } |Z| = \sqrt{R^2 + (X_L - X_C)^2}; \phi = \tan^{-1} \frac{X_L - X_C}{R}$$

$$\text{Take the supply voltage } V \text{ as reference phasor } V = V \angle 0^\circ = V + j0$$

Fig. 5.44. It is seen that operating V by $-j$ gives $-jV$ which is equal to OD . Hence we conclude that $-j$ is an operator which produces clockwise rotation of 90° .

Representation of Complex Numbers

The location of a point in a complex plane may also be represented in terms of the polar coordinates. In this representation, the radial distance r of the point from the origin, and the angle θ made between the radial line and the positive real axis, measured anticlockwise, are specified. In symbolic form it may be written as

$$A = r \angle \theta \quad (\text{read } r \text{ at an angle } \theta)$$

This representation is shown in Fig. 5.45.

Here $OP = r$ and $\angle xOP = \theta$; r is called the magnitude or absolute value or modulus of the complex number A and θ is known as the argument or angle of the complex number A . The magnitude is also written as $r = |A|$.



Fig. 5.45

Relationship Between Polar and Cartesian Forms

In cartesian form $A = a + jb$

In Polar form $A = r \angle \theta$ from Fig. 5.45

$$r = \sqrt{a^2 + b^2} = \sqrt{(\text{real term})^2 + (\text{imaginary term})^2}$$

$$\tan \theta = \frac{b}{a} = \frac{\text{imaginary term}}{\text{real term}}, \quad \theta = \tan^{-1} \frac{b}{a}$$

Therefore $a + jb = \sqrt{a^2 + b^2} \angle \tan^{-1} \frac{b}{a}$, similarly $a - jb = \sqrt{a^2 + b^2} \angle \tan^{-1} \frac{-b}{a}$

* We can use a to convert r and θ into polar form and vice versa.

Exponential form: $A = a + jb = r \cos \theta + jr \sin \theta = r (\cos \theta + j \sin \theta)$ from Euler's formulae $\cos \theta + j \sin \theta = e^{j\theta}$

$$\therefore A = re^{j\theta}$$

Equation is called the exponential form. In the exponential form the angle of a complex number should always be specified in radians.

- (a) $3 + j4$ (b) 6 (c) $j8$ (d) $5 - j5$ (e) $-2 + j2$

(a) $3 + j4 = r \angle \theta$ $r = \sqrt{3^2 + 4^2} = 5$

$\therefore \tan \theta = \frac{4}{3} = 1.333$ $\theta = \tan^{-1} 1.333 = 53.1^\circ$

$\therefore 3 + j4 = 5 \angle 53.1^\circ$

(b) 6 can be written as $6 + j0$

$$\therefore 6 + j0 = r \angle \theta$$

$$\theta = \tan^{-1} \frac{0}{6} = 0^\circ$$

(c) $j8$ can be written as $0 + j8$

$$\therefore r = \sqrt{(0^2 + 8^2)} = 8$$

(d) $5 - j5 = r \angle \theta$

$$\tan \theta = \frac{-5}{5} = \tan(-45^\circ)$$

(e) $-2 + j2 = r \angle \theta$

$$r = \sqrt{(-2)^2 + 2^2} = 2.828, \tan \theta = \frac{2}{-2} = -1 = \tan 135^\circ$$

$$\therefore -2 + j2 = 2.828 \angle 135^\circ$$

$$r = \sqrt{(6^2 + 0^2)} = 6$$

$$\therefore 6 = 6 + j0 = 6 \angle 0^\circ$$

$$\theta = \tan^{-1} \frac{8}{0} = 90^\circ, \quad j8 = 8 \angle 90^\circ$$

$$r = \sqrt{(5^2 + 5^2)} = 7.07$$

$$\theta = -45^\circ, \quad 5 - j5 = 7.07 \angle -45^\circ$$

Example 5.34 Convert the following to rectangular form:

(a) $8 \angle 30^\circ$ (b) $4 \angle -60^\circ$ (c) $6e^{j\pi/2}$ (d) $2e^{j\pi}$ (e) $10 \angle 135^\circ$ (f) $5e^{-j\pi/2}$

Soln. (a) $8 \angle 30^\circ = 8 (\cos 30^\circ + j \sin 30^\circ) = 6.93 + j4$

(b) $4 \angle -60^\circ = 4 [\cos(-60^\circ) + j \sin(-60^\circ)] = 4 (\cos 60^\circ - j \sin 60^\circ) = 2 - j3.46$

(c) $6e^{j\pi/2} = 6 (\cos \frac{\pi}{2} + j \sin \frac{\pi}{2}) = 0 + j6$

(d) $2e^{j\pi} = 2 (\cos \pi + j \sin \pi) = -2 + j0$

(e) $10 \angle 135^\circ = 10 (\cos 135^\circ + j \sin 135^\circ) = -7.07 + j7.07$

(f) $5e^{-j\pi/2} = 5 [\cos \frac{-\pi}{2} + j \sin \frac{-\pi}{2}] = 5 \cos \frac{\pi}{2} - j \sin \frac{\pi}{2} = 0 - j5$

Operations on Complex Numbers

Equality of complex numbers

Two complex numbers are equal if their real parts are equal and their imaginary parts are also equal. Thus, if

$$A = a + jb, \quad B = c + jd, \quad A = B \text{ if and only if, } \quad a = c \text{ and } b = d$$

$$\text{if } A = r_1 \angle \theta_1, \quad B = r_2 \angle \theta_2, \quad A = B \text{ if and only if, } \quad r_1 = r_2 \text{ and } \theta_1 = \theta_2$$

Sum of complex numbers

The sum of two complex numbers is defined as the complex number whose real part is the sum of the real parts of the two complex numbers and whose imaginary part is the sum of the imaginary parts of the two complex numbers. Thus, $(a + jb) + (c + jd) = (a + c) + j(b + d)$

$$(2 + j3) + (6 + j4) = (2 + 6) + j(3 + 4) = 8 + j7$$

The difference of two complex numbers is another complex number whose real part is the difference of the two real parts and whose imaginary part is the difference of the two imaginary parts:

For example,

$$(5 + j6) - (3 + j2) = (5 - 3) + j(6 - 2) = 2 - j4$$

$$(6 + j7) - j3 = (6 + 0) + j(7 - 3) = 6 + j4$$

Product of complex numbers

(a) Rectangular form

Two complex numbers are multiplied by normal laws of algebra. The result is simplified by putting $j^2 = -1$.

For example,

$$(a + jb)(c + jd) = ac + jad + jbc + j^2 bd$$

$$= (ac - bd) + j(ad + bc)$$

$$= j^2 5 = -5$$

$$(1 + j4)(2 - j3) = 2 - j3 + j8 - j^2 12 = 14 + j5$$

(b) Trigonometric form

$$r_1 (\cos \theta + j \sin \theta) \times r_2 (\cos \phi + j \sin \phi)$$

$$= r_1 r_2 [(\cos \theta \cos \phi - \sin \theta \sin \phi) + j(\sin \theta \cos \phi + \sin \phi \cos \theta)]$$

$$= r_1 r_2 [\cos(\theta + \phi) + j \sin(\theta + \phi)]$$

(c) Exponential form

$$r_1 e^{j\theta} \times r_2 e^{j\phi} = r_1 r_2 e^{j(\theta + \phi)}$$

Thus, the product of two complex numbers is a complex number whose magnitude is equal to the product of the magnitudes and whose angle is equal to the sum of the angles of the two original numbers.

(d) Polar form

Since polar and trigonometric forms are identical

$$r_1 \angle \theta \cdot r_2 \angle \phi = r_1 (\cos \theta + j \sin \theta) \cdot r_2 (\cos \phi + j \sin \phi) = r_1 r_2 \angle (\theta + \phi)$$

$$\text{Similarly, } r_1 \angle \theta \cdot r_2 \angle \phi \cdot r_3 \angle \psi = r_1 r_2 r_3 \angle (\theta + \phi + \psi)$$

It is seen that the multiplication in polar or exponential form is much easier and convenient than the multiplication in rectangular form.

Example 5.35 Find the product of the following complex numbers:

(a) $5 \angle 20^\circ \cdot 3 \angle 10^\circ$; (b) $4 \angle 30^\circ \cdot 6 \angle -45^\circ$; (c) $(4 + j4) \cdot 10 \angle 40^\circ$

(a) $5 \angle 20^\circ \times 3 \angle 10^\circ = (5 \times 3) \angle 20^\circ + 10^\circ = 15 \angle 30^\circ$

(b) $4 \angle 30^\circ \times 6 \angle -45^\circ = (4 \times 6) \angle 30^\circ - 45^\circ = 24 \angle -15^\circ$

(c) Here we change $4 + j4$ into polar form.

$$4 + j4 = \sqrt{4^2 + 4^2} \angle \tan^{-1} 4/4 = 5.65 \angle 45^\circ$$

$$\therefore 5.65 \angle 45^\circ \times 10 \angle 40^\circ = 56.5 \angle 85^\circ$$

Division of Complex Numbers

(a) Rectangular form

$$\frac{a + jb}{c + jd} = \frac{(a + jb)(c - jd)}{(c + jd)(c - jd)} = \frac{ac + bd + j(bc - ad)}{c^2 + d^2} = \frac{ac + bd}{c^2 + d^2} + j \frac{bc - ad}{c^2 + d^2}$$

(b) Polar form

$$\frac{r_1 \angle \theta}{r_2 \angle \phi} = \frac{r_1}{r_2} \angle \theta - \phi = \frac{r_1}{r_2} \angle \theta - \phi$$

Similarly, $\frac{r_1 \angle \theta}{r_2 \angle -\phi} = \frac{r_1}{r_2} \angle \theta + \phi$

Example 5.37 Simplify the following: $\frac{24 \angle 30^\circ}{6 \angle 10^\circ} \cdot \frac{80 \angle 25^\circ}{6 + j8}$

Soln. (a) $\frac{24 \angle 30^\circ}{6 \angle 10^\circ} = \frac{24}{6} \angle 30^\circ - 10^\circ = 4 \angle 20^\circ$; $\frac{80 \angle 25^\circ}{6 + j8} = \frac{r_1}{r_2} \angle (\theta - \phi) = \frac{r_1}{r_2} [\cos(\theta - \phi) + j \sin(\theta - \phi)]$

(b) $80 \angle 25^\circ = 80 \angle -35^\circ$

(c) We first change $(6 + j8)$ in polar form.

$$6 + j8 = \sqrt{6^2 + 8^2} \angle \tan^{-1} \frac{8}{6} = 10 \angle 53.1^\circ$$

$$\frac{80 \angle 25^\circ}{6 + j8} = \frac{80 \angle 25^\circ}{10 \angle 53.1^\circ} = 8 \angle 25^\circ - 53.1^\circ = 8 \angle -28.1^\circ$$

and $4 \angle 20^\circ \cdot 8 \angle -28.1^\circ = 32 \angle -8.1^\circ$

$$32 \angle -8.1^\circ = 32 \cos(-8.1^\circ) + j 32 \sin(-8.1^\circ)$$

$$= 31.5 - j 4.5$$

$$A^n = (Ae^{j\alpha})^n = A^n e^{jn\alpha} = A^n \angle n\alpha$$

PHASOR ALGEBRA

Addition and Subtraction

To add and subtract phasors we must use rectangular form. Simply add or subtract like

Multiplication: Phasors may be multiplied in either form. However, it is very convenient to work with the polar form. Simply multiply magnitudes and add angles.

Division: Division of one phasor by another is best done with the polar form. Divide the magnitude of the numerator by the magnitude of the denominator, and subtract algebraically the angle of the denominator from the angle of the numerator. In other words, change the sign of the angle of the denominator and then add it to the angle of the numerator.

Complex Number Representation of Sinusoids: We have seen that sinusoids can be represented by phasors. Since phasors can be expressed in terms of complex numbers, sinusoids can also be expressed in terms of complex numbers. Simple problems or systems of equations can be solved conveniently with the help of phasor diagrams. The complex number representation of sinusoids simplifies the solution of ac circuit problems. In complex notation, equations representing alternating voltages and currents and their relationships can be expressed in algebraic forms:

Representation of Voltage, Current and Impedance:

In general, the voltage and current in an ac circuit can be expressed in the form

$$v = V_m \cos(\omega t + \alpha) \quad i = I_m \cos(\omega t + \beta)$$

where V_m and I_m are the maximum values of v and i respectively, and α and β are the phase angles of v and i respectively with respect to a reference direction. Usually, v or i is used as the reference phasor, so that either α is zero or β is zero.

Pure Resistance: Thus, the impedance of a resistor in complex notation is R , so that $V = V \angle 0^\circ$. Since

Pure Inductance: In a circuit containing pure inductance, the current lags the voltage by 90° ,

so that if $V_L = V_L \angle 0^\circ$, then $I_L = I_L \angle -90^\circ = I_L (0 - j1)$

$$\frac{V_L}{I_L} = \frac{V_L \angle 0^\circ}{I_L \angle -90^\circ} = \frac{V_L}{I_L} \angle 90^\circ$$

$$Z_L = X_L \angle 90^\circ = \omega L \angle 90^\circ = jX_L = j\omega L$$

$$Z_L =$$

Capacitance : In a purely capacitive circuit, the current leads the voltage by 90° so that if $V_c = V_r \angle 0^\circ$, then $I_c = I \angle 90^\circ$ $I_c = I \angle 90^\circ$. The complex impedance of a purely capacitive

$$Z_c = \frac{V_c}{I_c} = \frac{V_c \angle 0^\circ}{I_c \angle 90^\circ} = \frac{V_c}{I_c} \angle -90^\circ \text{ or } Z_c = X_c \angle -90^\circ = \frac{1}{\omega C} \angle -90^\circ = -jX_c = -j \frac{1}{\omega C}$$

Series AC Circuits

The general rules of series ac circuits are the same as for dc circuits. However, we work with phasors.

Current : Current is the same throughout in any series circuit

$$\text{Total Current } I_T = \frac{\text{total voltage}}{\text{total impedance}} = \frac{V_T}{Z_T}$$

where V_1, V_2, V_3 are the voltage drops in impedances Z_1, Z_2, Z_3

Impedance : The total impedance of a series circuit is the phasor sum of the impedances of the circuit.

$$\text{Similarly, } Z_1 = \frac{V_1}{I}, Z_2 = \frac{V_2}{I}, Z_3 = \frac{V_3}{I} \quad \text{Also, } Z = R + j(X_L - X_C)$$

Voltage : The phasor sum of the voltage drops is equal to the applied voltage

$$Z_{RL} = Z_R + Z_L = (R + j0) + (0 + jX_L) \text{ or } Z_{RL} = R + jX_L = I_o Z_o$$

Series RL Circuit : The total impedance of a series RL ac circuit is given by

$$Z = Z_R + Z_L = (R + j0) + (0 + jX_L) \text{ or } Z = R + jX_L$$

Circuit : The total impedance of a series RLC circuit is

$$Z = R + j(X_L - X_C)$$

$$Z = R + j(X_L - X_C) \quad (i)$$

Consider a circuit in which the voltage leads the current by an angle ϕ

$$V = V \angle \theta + \phi$$

We know that $P = VI \cos \phi$, $Q = VI \sin \phi$

We shall define complex power S as $S = P + jQ$

P , Q and S are shown in Fig. 5.47.

The right angled triangle OAB formed by P , Q and S is called the power triangle. It is to be noted the phase angle ϕ of the impedance $Z = Z$

$$Q = S \sin \phi = P \tan \phi$$

$$\text{and } S^2 = P^2 + Q^2$$

flit s 4



$$S = P + jQ = S \cos \phi + jS \sin \phi = VI \cos \phi + jVI \sin \phi = VI(\cos \phi + j \sin \phi) \quad \dots (iii)$$

$$\therefore S = VIe^{j\phi} = VI \angle \phi$$

$$\text{Since } I = I \angle \theta, I^* = I \angle -\theta, VI^* = (VI \angle \theta + \phi)(I \angle -\theta)$$

$$VI^* = VI \angle \phi \quad \dots (vi)$$

$$\text{Thus } S = P + jQ = VI^*, P = \text{Re}[VI^*] = VI \cos \phi = I^2 R \quad \dots (vii)$$

$$Q = \text{Im}[VI^*] = VI \sin \phi = I^2 X$$

Equation (vi) shows that active power P can be obtained by taking the real part of the product of the conjugate of current. Equation (vii) shows that reactive power Q can be obtained by taking the imaginary part of the product of the complex expression of the voltage and the complex expression of the conjugate of current.

example, if $V = a + jb$, $I = c + jd$, then $I^* = c - jd$, $S = VI^*$
 $= (a + jb)(c - jd) = (ac + bd) + j(bc - ad) = P + jQ$

$$Q = \text{Im}[VI^*] = (bc - ad) \quad \dots (ix)$$

Step-by-step calculation

series AC circuits.

Express R in ohms, L in henrys, C in farads and f in hertz

$$\text{Determine the impedance in rectangular form by the formula } Z = R + j(X_L - X_C) \Omega$$

4.

Determine the impedance in rectangular form also by the formula $Z = R + j(X_L - X_C)$

6

$$\text{where } |Z| = \sqrt{R^2 + (X_L - X_C)^2}; \phi = \tan^{-1} \frac{X_L - X_C}{R}$$

$$\text{Take the supply voltage } V \text{ as reference phasor } V = V \angle 0^\circ = V + j0$$

10.

11.

Determine the circuit current by Ohm's law

$$i = \frac{V}{Z} = \frac{230 \angle 0^\circ}{Z}$$

8.

Express I in rectangular form also.

Determine the power factor $\cos \phi$ to four places of decimal. Specify whether the power factor is leading or lagging. Is it taken positive and Ceiling VAR is taken negative.

9.

12. Apportion the voltage drop each element

12.

Determine the voltage drop each element

$$V_R = IZ_R = I'R, \quad V_L = IZ_L = I(jX_L), \quad V_C = IZ_C = I(-jX_C)$$

13.

Determine the complex power $S = P + jQ$. The real part of VI^* gives the active power P in watts and the imaginary part gives the reactive voltamperes in VAR. The magnitude of VI^* gives voltamperes

$$P = \text{Re}[VI^*] \text{ W}, \quad Q = \text{Im}[VI^*] \text{ VAR}, \quad S = |VI^*| \text{ VA}$$

$$\text{Alternatively } P = VI \cos \phi = I^2 R, \quad S = VI, \quad Q = VI \sin \phi$$

Example 5.38 A resistance of 60Ω is connected in series with a $120 \mu\text{F}$ capacitor across a 230V , 50 Hz supply. Determine (a) the current through the circuit, (b) the phase difference between voltage and current, (c) the voltage across the resistor, (d) the voltage across the capacitor, (e) the power consumed in the circuit.

$$R = 60 \Omega, \quad C = 120 \mu\text{F} = 120 \times 10^{-6} \text{ F}$$

Taking the supply voltage v as reference phasor we have $v = 230 \angle 0^\circ$

$$Z = R - jX_C = 60 - j26.526 = 65.6 \angle -23.85^\circ \Omega$$

(b) Phase difference between V and $I = \phi = 23.85^\circ - 0^\circ = 23.85^\circ$

The current

$$(c) \text{ Voltage across the resistor, } V_R = IR = 3.506 \times 60 = 210.36 \text{ V}$$

$$(d) \text{ Voltage across the capacitor, } V_C = IX_C = 3.506 \times 26.526 = 93 \text{ V}$$

$$(e) \text{ Power consumed in the circuit, } P = I^2 R = (3.506)^2 \times 60 = 737.5 \text{ W}$$

Chapter (5)

Transformer

Introduction

The transformer is probably one of the most useful electrical devices ever invented. It can change the magnitude of alternating voltage or current from one value to another. This useful property of transformer is mainly responsible for the widespread use of alternating currents rather than direct currents i.e., electric power is generated, transmitted and distributed in the form of alternating current. Transformers have no moving parts, rugged and durable in construction, thus requiring very little attention. They also have a very high efficiency—as high as 99%. In this chapter, we shall study some of the basic properties of transformers.

Transformer

A transformer is a static piece of equipment used either for raising or lowering the voltage of an a.c. supply with a corresponding decrease or increase in current. It essentially consists of two windings, the primary and secondary, wound on a common laminated magnetic core as shown in Fig. (7.1). The winding connected to the a.c. source is called primary winding (or primary) and the one connected to load is called secondary winding (or secondary). The alternating voltage V_1 whose magnitude is to be changed is applied to the primary. Depending upon the number of turns of the primary (N_1) and secondary (N_2), an alternating e.m.f. E_2 is induced in the secondary. This induced e.m.f. E_2 in the secondary causes a secondary current I_2 . Consequently, terminal voltage V_2 will appear across the load. If $V_2 > V_1$, it is called a step up-transformer. On the other hand, if $V_2 < V_1$, it is called a step-down transformer.

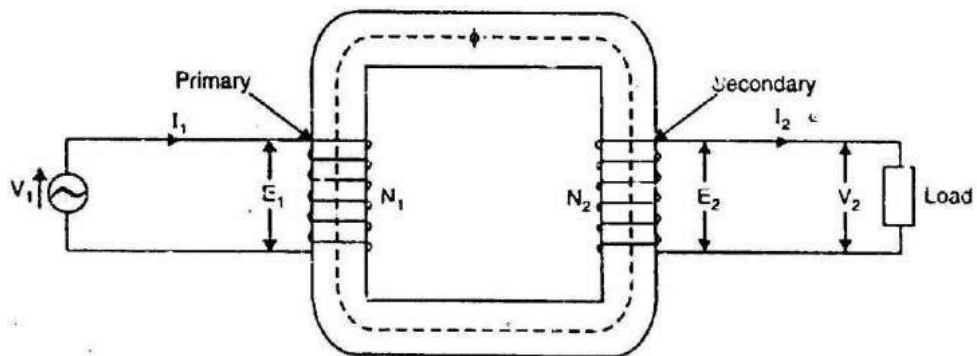

Fig.(7.1)

Working

When an alternating voltage V_1 is applied to the primary, an alternating flux ϕ is set up in the core. This alternating flux links both the windings and induces e.m.f.s E_1 and E_2 in them according to Faraday's laws of electromagnetic induction. The e.m.f. E_1 is termed as primary e.m.f. and e.m.f. E_2 is termed as secondary e.m.f.

$$\text{and} \quad E_2 = -N_2 \frac{d\phi}{dt}$$
$$\therefore \frac{E_2}{E_1} = \frac{N_2}{N_1}$$

Note that magnitudes of E_2 and E_1 depend upon the number of turns on the secondary and primary respectively. If $N_2 > N_1$, then $E_2 > E_1$ (or $V_2 > V_1$) and we get a step-up transformer. On the other hand, if $N_2 < N_1$, then $E_2 < E_1$ (or $V_2 < V_1$) and we get a step-down transformer. If load is connected across the secondary winding, the secondary e.m.f. E_2 will cause a current I_2 to flow through the load. Thus, a transformer enables us to transfer a.c. power from one circuit to another with a change in voltage level.

The following points may be noted carefully:

- 0 The transformer action is based on the laws of electromagnetic induction.
- 1 There is no electrical connection between the primary and secondary. The a.c. power is transferred from primary to secondary through magnetic flux.
- 2 There is no change in frequency i.e., output power has the same frequency as the input power.
- 3 The losses that occur in a transformer are:
 - 0 core losses—eddy current and hysteresis losses
 - 1 copper losses—in the resistance of the windings

In practice, these losses are very small so that output power is nearly equal to the input primary power. In other words, a transformer has very high efficiency.

Theory of an Ideal Transformer

An ideal transformer is one that has

- 0 no winding resistance
- 1 no leakage flux i.e., the same flux links both the windings
- 2 no iron losses (i.e., eddy current and hysteresis losses) in the core

Although ideal transformer cannot be physically realized, yet its study provides a very powerful tool in the analysis of a practical transformer. In fact, practical transformers have properties that approach very close to an ideal transformer.

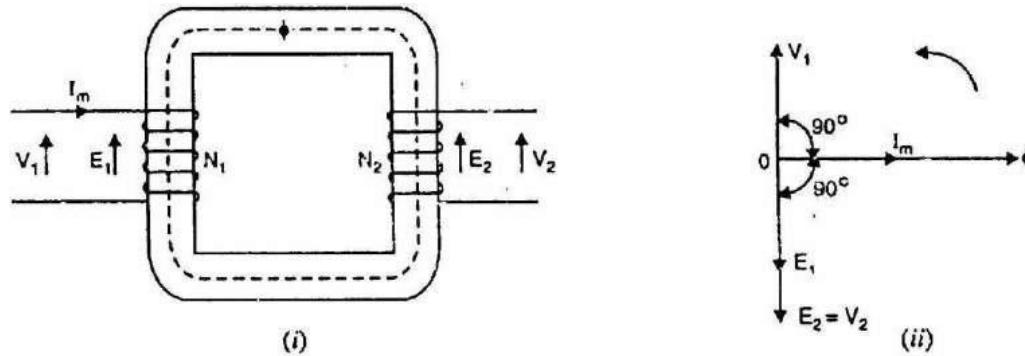

Fig.(7.2)

Consider an ideal transformer on no load i.e., secondary is open-circuited as shown in Fig. (7.2 (i)). Under such conditions, the primary is simply a coil of pure inductance. When an alternating voltage V_1 is applied to the primary, it draws a small magnetizing current I_m which lags behind the applied voltage by 90° . This alternating current I_m produces an alternating flux f which is proportional to and in phase with it. The alternating flux f links both the windings and induces e.m.f. E_1 in the primary and e.m.f. E_2 in the secondary. The primary e.m.f. E_1 is, at every instant, equal to and in opposition to V_1 (Lenz's law). Both e.m.f.s E_1 and E_2 lag behind flux f by 90° (See Sec. 7.3). However, their magnitudes depend upon the number of primary and secondary turns.

Fig. (7.2 (ii)) shows the phasor diagram of an ideal transformer on no load. Since flux f is common to both the windings, it has been taken as the reference phasor. As shown in Sec. 7.3, the primary e.m.f. E_1 and secondary e.m.f. E_2 lag behind the flux f by 90° . Note that E_1 and E_2 are in phase. But E_1 is equal to V_1 and 180° out of phase with it.

E.M.F. Equation of a Transformer

Consider that an alternating voltage V_1 of frequency f is applied to the primary as shown in Fig. (7.2 (i)). The sinusoidal flux f produced by the primary can be represented as:

$$\phi = \phi_m \sin \omega t$$

The instantaneous e.m.f. e_1 induced in the primary is

$$-2\pi f N_1 \phi_m \sin(\omega t - 90^\circ) \quad (1)$$

It is clear from the above equation that maximum value of induced e.m.f. in the primary is

$$E_{m1} = 2\pi f N_1 \phi_m$$

The r.m.s. value E_1 of the primary e.m.f. is

$$E_1 = \frac{E_{m1}}{\sqrt{2}} = \frac{2\pi f N_1 \phi_m}{\sqrt{2}}$$

or $E_1 = 4.44 f N_1 \phi_m$

Similarly $E_2 = 4.44 f N_2 \phi_m$

In an ideal transformer, $E_1 = V_1$ and $E_2 = V_2$.

Note. It is clear from exp. (i) above that e.m.f. E_1 induced in the primary lags behind the flux ϕ by 90° . Likewise, e.m.f. E_2 induced in the secondary lags behind flux ϕ by 90° .

Voltage Transformation Ratio (K)

From the above equations of induced e.m.f., we have (See Fig. 7.3),

$$\frac{E_2}{E_1} = \frac{N_2}{N_1} = K$$

The constant K is called *voltage transformation ratio*. Thus if $K = 5$ (i.e. $N_2/N_1 = 5$), then $E_2 = 5 E_1$.

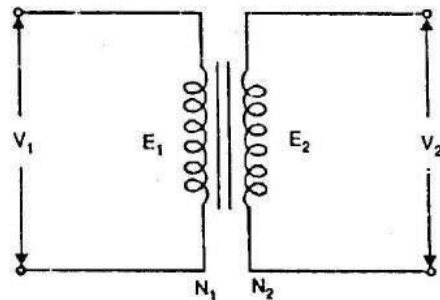

Fig.(7.3)

For an ideal transformer;

(i) $E_1 = V_1$ and $E_2 = V_2$ as there is no voltage drop in the windings.

$$\therefore \frac{E_2}{E_1} = \frac{V_2}{V_1} = \frac{N_2}{N_1} = K$$

(ii) there are no losses. Therefore, volt-amperes input to the primary are equal to the output volt-amperes i.e.

$$V_1 I_1 = V_2 I_2$$

Hence, currents are in the inverse ratio of voltage transformation ratio. This simply means that if we raise the voltage, there is a corresponding decrease of current.

Practical Transformer

A practical transformer differs from the ideal transformer in many respects. The practical transformer has (i) iron losses (ii) winding resistances and (iii) magnetic leakage, giving rise to leakage reactances.

- 0 **Iron losses.** Since the iron core is subjected to alternating flux, there occurs eddy current and hysteresis loss in it. These two losses together are known as iron losses or core losses. The iron losses depend upon the supply frequency, maximum flux density in the core, volume of the core etc. It may be noted that magnitude of iron losses is quite small in a practical transformer.
- 1 **Winding resistances.** Since the windings consist of copper conductors, it immediately follows that both primary and secondary will have winding resistance. The primary resistance R_1 and secondary resistance R_2 act in series with the respective windings as shown in Fig. (7.4). When current flows through the windings, there will be power loss as well as a loss in voltage due to IR drop. This will affect the power factor and E_1 will be less than V_1 while V_2 will be less than E_2 .

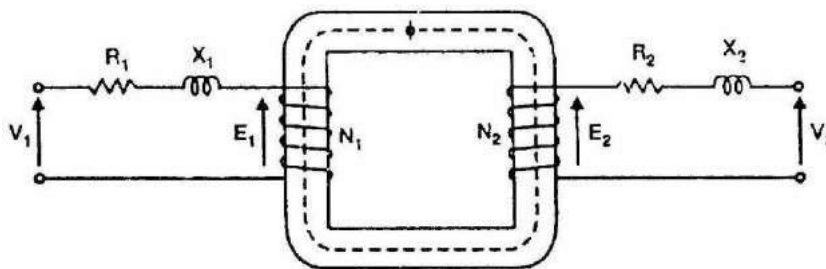

Fig.(7.4)

- 0 **Leakage reactances.** Both primary and secondary currents produce flux. The flux ϕ which links both the windings is the useful flux and is called mutual flux. However, primary current would produce some flux ϕ which would not link the secondary winding (See Fig. 7.5). Similarly, secondary current would produce some flux ϕ that would not link the primary winding. The flux such as ϕ_1 or ϕ_2 which links only one winding is called leakage flux. The leakage flux paths are mainly through the air. The effect

of these leakage fluxes would be the same as though inductive reactance were connected in series with each winding of transformer that had no leakage flux as shown in Fig. (7.4). In other words, the effect of primary leakage flux f_1 is to introduce an inductive reactance X_1 in series with the primary winding as shown in Fig. (7.4). Similarly, the secondary leakage flux f_2 introduces an inductive reactance X_2 in series with the secondary winding. There will be no power loss due to leakage reactance. However, the presence of leakage reactance in the windings changes the power factor as well as there is voltage loss due to IX drop.

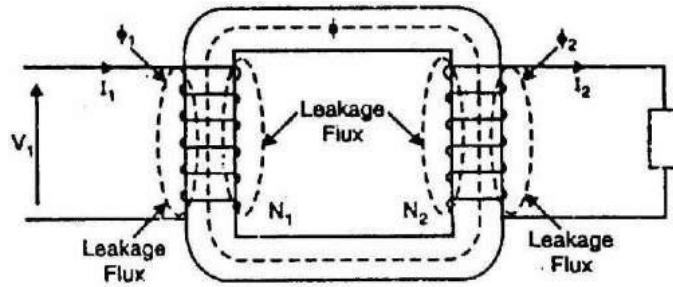

Fig.(7.5)

Note. Although leakage flux in a transformer is quite small (about 5% of f) compared to the mutual flux f , yet it cannot be ignored. It is because leakage flux paths are through air of high reluctance and hence require considerable e.m.f. It may be noted that energy is conveyed from the primary winding to the secondary winding by mutual flux f which links both the windings.

Practical Transformer on No Load

Consider a practical transformer on no load i.e., secondary on open-circuit as shown in Fig. (7.6 (i)). The primary will draw a small current I_0 to supply (i) the iron losses and (ii) a very small amount of copper loss in the primary. Hence the primary no load current I_0 is not 90° behind the applied voltage V_1 but lags it by an angle $\phi_0 < 90^\circ$ as shown in the phasor diagram in Fig. (7.6 (ii)).

No load input power, $W_0 = V_1 I_0 \cos \phi_0$

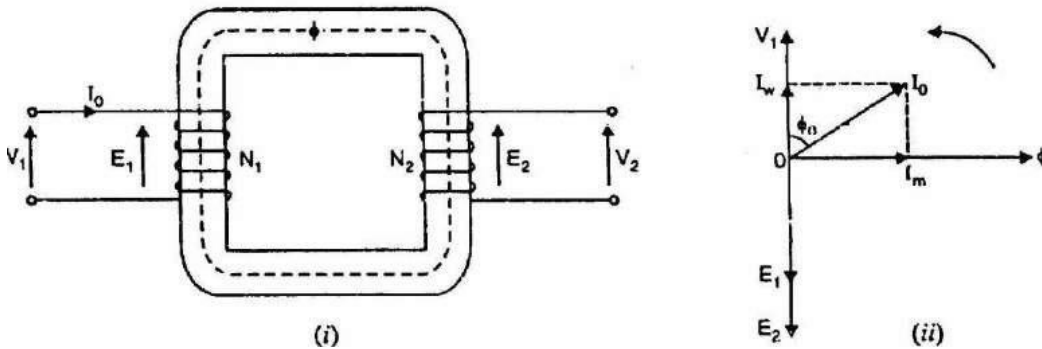

Fig.(7.6)

As seen from the phasor diagram in Fig. (7.6 (ii)), the no-load primary current I_0 can be resolved into two rectangular components viz.

The component I_w in phase with the applied voltage V_1 . This is known as active or working or iron loss component and supplies the iron loss and a very small primary copper loss.

$$I_w = I_0 \cos \phi_0$$

- (b) The component I_m lagging behind V_1 by 90° and is known as magnetizing component. It is this component which produces the mutual flux ϕ in the core.

$$I_m = I_0 \sin \phi_0$$

Clearly, I_0 is phasor sum of I_m and I_w .

$$\therefore I_0 = \sqrt{I_m^2 + I_w^2}$$

$$\text{No load p.f.,} \quad \cos \phi_0 = \frac{I_w}{I_0}$$

It is emphasized here that no load primary copper loss (i.e. $I_0^2 R_1$) is very small and may be neglected. Therefore, the no load primary input power is practically equal to the iron loss in the transformer i.e.,

$$\text{No load input power, } W_0 = \text{Iron loss}$$

Note. At no load, there is no current in the secondary so that $V_2 = E_2$. On the primary side, the drops in R_1 and X_1 , due to I_0 are also very small because of the smallness of I_0 . Hence, we can say that at no load, $V_1 = E_1$.

Ideal Transformer on Load

Let us connect a load Z_L across the secondary of an ideal transformer as shown in Fig. (7.7 (i)). The secondary e.m.f. E_2 will cause a current I_2 to flow through the load.

The angle at which I_2 leads or lags V_2 (or E_2) depends upon the resistance and reactance of the load. In the present case, we have considered inductive load so that current I_2 lags behind V_2 (or E_2) by ϕ_2 .

The secondary current I_2 sets up an m.m.f. $N_2 I_2$ which produces a flux in the opposite direction to the flux ϕ originally set up in the primary by the magnetizing current. This will change the flux in the core from the original value. However, the flux in the core should not change from the original value.

In order to fulfill this condition, the primary must develop an m.m.f. which exactly counterbalances the secondary m.m.f. $N_2 I_2$. Hence a primary current I_1 must flow such that:

$$N_1 I_1 = N_2 I_2$$

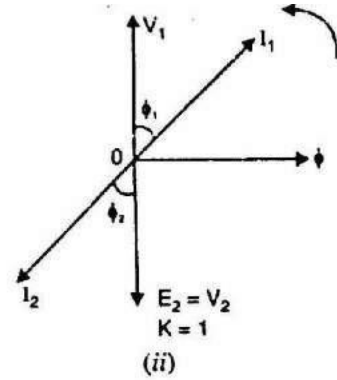
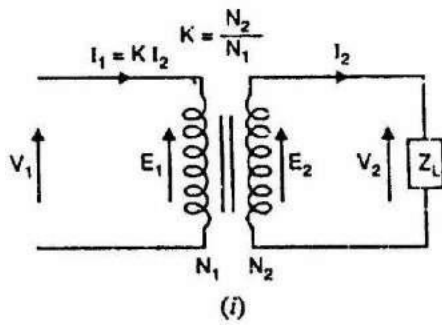

Fig.(7.7)

Thus when a transformer is loaded and carries a secondary current I_2 , then a current I_1 , ($= K I_2$) must flow in the primary to maintain the m.m.f. balance. In other words, the primary must draw enough current to neutralize the demagnetizing effect of secondary current so that mutual flux f remains constant. Thus as the secondary current increases, the primary current I_1 ($= K I_2$) increases in unison and keeps the mutual flux f constant. The power input, therefore, automatically increases with the output. For example if $K = 2$ and $I_2 = 2A$, then primary will draw a current $I_1 = K I_2 = 2 \times 2 = 4A$. If secondary current is increased to $4A$, then primary current will become $I_1 = K I_2 = 2 \times 4 = 8A$.

Phaser diagram: Fig. (7.7 (ii)) shows the phasor diagram of an ideal transformer on load. Note that in drawing the phasor diagram, the value of K has been assumed unity so that primary phasors are equal to secondary phasors. The secondary current I_2 lags behind V_2 (or E_2) by f_2 . It causes a primary current $I_1 = K I_2 = 1 \times I_2$ which is in antiphase with it.

$$f_1 = f_2$$

$$\text{or} \quad \cos f_1 = \cos f_2$$

Thus, power factor on the primary side is equal to the power factor on the secondary side.

Since there are no losses in an ideal transformer, input primary power is equal to the secondary output power i.e.,

$$V_1 I_1 \cos f_1 = V_2 I_2 \cos f_2$$

Practical Transformer on Load

We shall consider two cases (i) when such a transformer is assumed to have no winding resistance and leakage flux (ii) when the transformer has winding resistance and leakage flux.

(i) No winding resistance and leakage flux

Fig. (7.8) shows a practical transformer with the assumption that resistances and leakage reactances of the windings are negligible. With this assumption, $V_2 = E_2$ and $V_1 = E_1$. Let us take the usual case of inductive load which causes the secondary current I_2 to lag the secondary voltage V_2 by ϕ_2 . The total primary current I_1 must meet two requirements viz.

It must supply the no-load current I_0 to meet the iron losses in the transformer and to provide flux in the core.

It must supply a current I'_2 to counteract the demagnetizing effect of secondary current I_2 . The total primary current I_1 is the phasor sum of I'_2 and I_0 i.e.,

$$I_1 = I'_2 + I_0$$

where $I'_2 = -KI_2$

Note that I'_2 is 180° out of phase with I_2 .

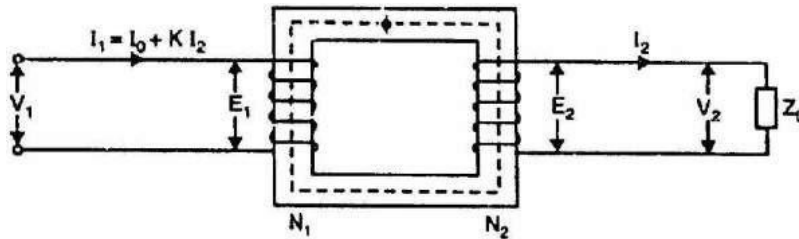

Fig.(7.8)

Phasor diagram. Fig. (7.9) shows the phasor diagram for the usual case of inductive load. Both E_1 and E_2 lag behind the mutual flux ϕ by 90° . The current I'_2 represents the primary current to neutralize the demagnetizing effect of secondary current I_2 . Now $I'_2 = K I_2$ and is antiphase with I_2 . I_0 is the no-load current of the transformer. The phasor sum of I'_2 and I_0 gives the total primary current I_1 . Note that in drawing the phasor diagram, the value of K is assumed to be unity so that primary phasors are equal to secondary phasors.

Primary p.f. = cos ϕ_1

Secondary p.f. = $\cos \phi_2$

Primary input power = $V_1 I_1 \cos \phi_1$
 Secondary output power = $V_2 I_2 \cos \phi_2$

Transformer with resistance and leakage reactance

Fig. (7.10) shows a practical transformer having winding resistances and leakage reactances. These are the actual conditions that exist in a transformer. There is voltage drop in R_1 and X_1 so that primary e.m.f. E_1 is less than

the applied voltage V_1 . Similarly, there is voltage drop in R_2 and X_2 so that secondary terminal voltage V_2 is less than the secondary e.m.f. E_2 . Let us take the usual case of inductive load which causes the secondary current I_2 to lag behind the secondary voltage V_2 by ϕ_2 . The total primary current I_1 must meet two requirements viz.

It must supply the no-load current I_0 to meet the iron losses in the transformer and to provide flux in the core.

It must supply a current I_2' to counteract the demagnetizing effect of secondary current I_2

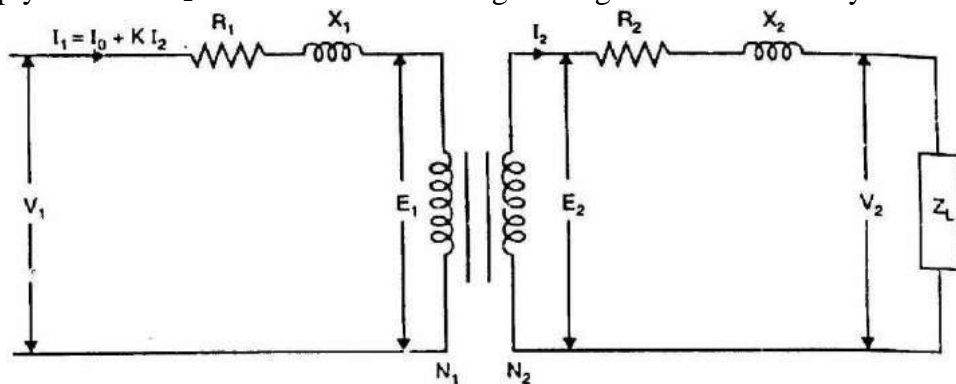
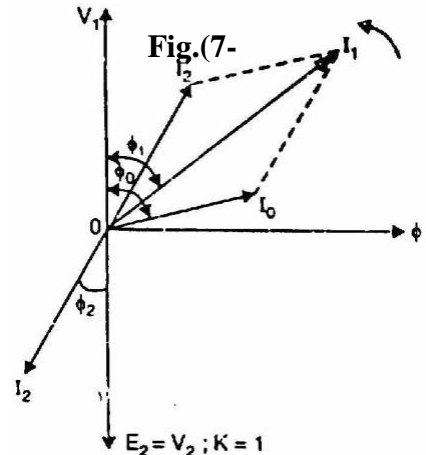

Fig.(7.10)

The total primary current I_1 will be the phasor sum of I_2' and I_0

$$\begin{aligned} \text{i.e., } I_1 &= I_2' + I_0 \quad \text{where} \quad I_2' = -KI_2 \\ V_1 &= -E_1 + I_1(R_1 + jX_1) \quad \text{where} \quad I_1 = I_0 + (-KI_2) \\ &= -E_1 + I_1 Z_1 \end{aligned}$$

$$V_2 = E_2 - I_2(R_2 + jX_2)$$

$$= E_2 - I_2Z_2$$

Phasor diagram. Fig. (7.11) shows the phasor diagram of a practical transformer for the usual case of inductive load. Both E_1 and E_2 lag the mutual flux ϕ by 90° . The current I_2' represents the primary current to neutralize the demagnetizing effect of secondary current I_2 . Now $I_2' = K I_2$ and is opposite to I_2 . Also I_0 is the no-load current of the transformer. The phasor sum of I_2' and I_0 gives the total primary current I_1 .

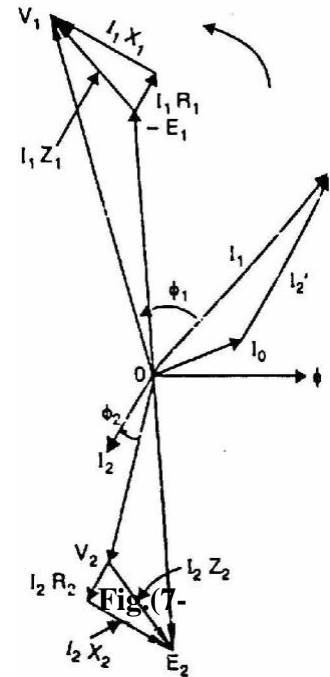

Note that counter e.m.f. that opposes the applied voltage V_1 is $-E_1$. Therefore, if we add I_1R_1 (in phase with I_1) and I_1X_1 (90° ahead of I_1) to $-E_1$, we get the applied primary voltage V_1 . The phasor E_2 represents the induced e.m.f. in the secondary by the mutual flux ϕ . The secondary terminal voltage V_2 will be what is left over after subtracting I_2R_2 and I_2X_2 from E_2 .

- Load power factor = $\cos \phi_2$
- Primary power factor = $\cos \phi_1$
- Input power to transformer, $P_1 = V_1I_1 \cos \phi_1$
- Output power of transformer, $P_2 = V_2I_2 \cos \phi_2$

Note: The reader may draw the phasor diagram of a loaded transformer for (i) unity p.f. and (ii) leading p.f. as an exercise.

Exact Equivalent Circuit of a Loaded Transformer

Fig. (7.19) shows the exact equivalent circuit of a transformer on load. Here R_1 is the primary winding resistance and R_2 is the secondary winding resistance. Similarly, X_1 is the leakage reactance of primary winding and X_2 is the leakage reactance of the secondary winding. The parallel circuit $R_0 - X_0$ is the no-load equivalent circuit of the transformer. The resistance R_0 represents the core losses (hysteresis and eddy current losses) so that current I_w which supplies the core losses is shown passing through R_0 . The inductive reactance X_0 represents a loss-free coil which passes the magnetizing current I_m . The phasor sum of I_w and I_m is the no-load current I_0 of the transformer.

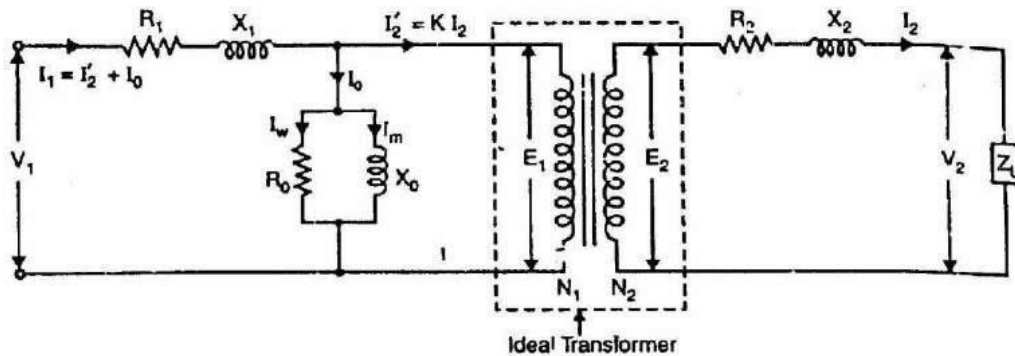

Fig. (7.19)

Note that in the equivalent circuit shown in Fig. (7.19), the imperfections of the transformer have been taken into account by various circuit elements. Therefore, the transformer is now the ideal one. Note that equivalent circuit has created two normal electrical circuits separated only by an ideal transformer whose function is to change values according to the equation:

$$\frac{E_2}{E_1} = \frac{N_2}{N_1} = \frac{I_1}{I_2}$$

The following points may be noted from the equivalent circuit:

When the transformer is on no-load (i.e., secondary terminals are open-circuited), there is no current in the secondary winding. However, the primary draws a small no-load current I_0 . The no-load primary current I_0

is composed of (a) magnetizing current (I_m) to create magnetic flux in the core and (b) the current I_w required to supply the core losses.

When the secondary circuit of a transformer is closed through some external load Z_L , the voltage E_2 induced in the secondary by mutual flux will produce a secondary current I_2 . There will be $I_2 R_2$ and $I_2 X_2$ drops in the secondary winding so that load voltage V_2 will be less than E_2 .

$$V_2 = E_2 - I_2 (R_2 + j X_2) = E_2 - I_2 Z_2$$

When the transformer is loaded to carry the secondary current I_2 , the primary current consists of two components:

The no-load current I_0 to provide magnetizing current and the current required to supply the core losses.

The primary current $I_2' (= K I_2)$ required to supply the load connected to the secondary.

$$\text{Total primary current } I_1 = I_0 + (-K I_2)$$

Simplified Equivalent Circuit of a Loaded Transformer

The no-load current I_0 of a transformer is small as compared to the rated primary current. Therefore, voltage drops in R_1 and X_1 due to I_0 are negligible. The equivalent circuit shown in Fig. (7.19) above can, therefore, be simplified by transferring the shunt circuit $R_0 - X_0$ to the input terminals as shown in Fig. (7.20). This modification leads to only slight loss of accuracy.

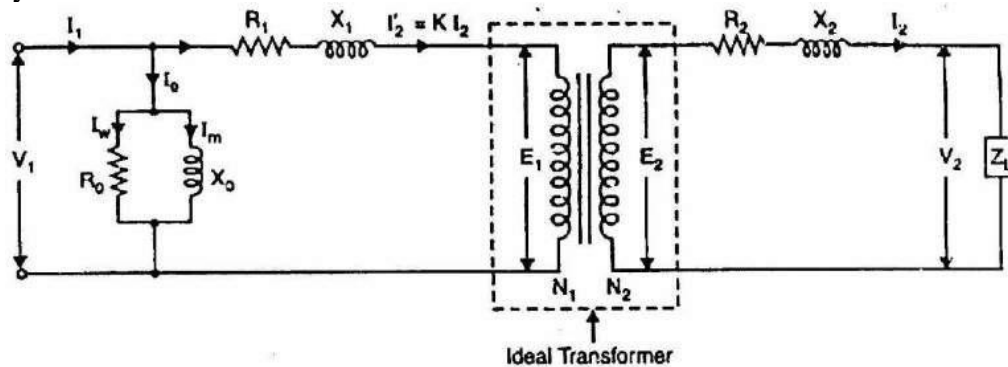

Fig.(7.20)

is in phase with I_2 and the voltage drop $I_2 X_{01}$, leads I_2 by 90° . When these voltage drops are added to V_2 , we get the input voltage V_1 .

The current I_w is in phase with V_1 while the magnetization current I_m lags behind V_1 by 90° . The phasor sum of I_w and I_m is the no-load current I_0 . The phasor sum of I_0 and I_2 is the input current I_1 .

Equivalent circuit referred to secondary.

If all the primary quantities are referred to secondary, we get the equivalent circuit of the transformer referred to secondary as shown in Fig. (7.23 (i)). This further reduces to Fig. (7.23 (ii)). Note that when primary quantities are referred to secondary resistances/reactances/impedances are multiplied by K^2 , voltages are multiplied by K , and currents are divided by K .

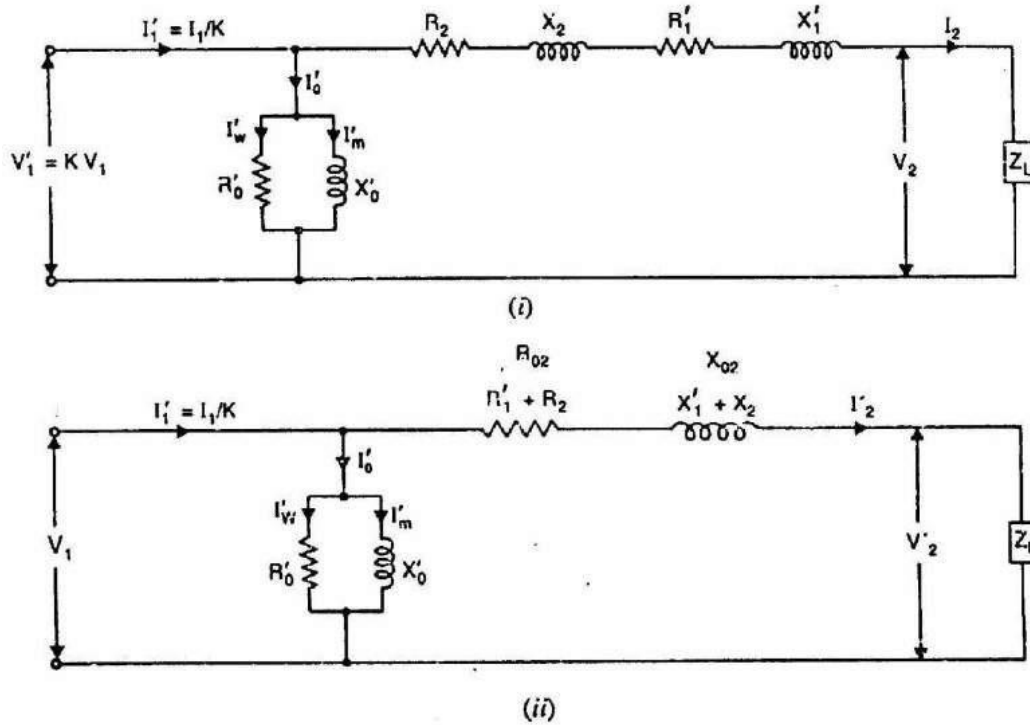

Fig. (7.23)

Phasor diagram. Fig. (7.24) shows the phasor diagram of the equivalent circuit shown in Fig. (7.23 (ii)). The load voltage V_2 is chosen as the

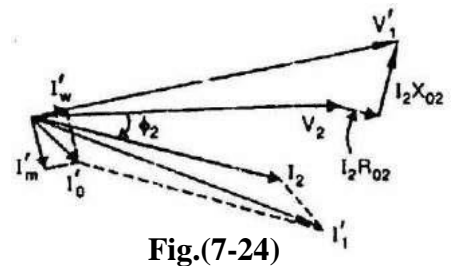

Fig.(7-24)

reference phasor. The load current I_2 is shown lagging the load voltage V_2 by phase angle ϕ_2 . The voltage drop $I_2 R_{02}$ is in phase with I_2 and the voltage drop $I_2 X_{02}$ leads I_2 by 90° . When these voltage drop are added to V_2 , we get the referred primary voltage $V'_1 (= KV_1)$.

The current I'_w is in phase with V'_1 while the magnetizing current I'_m lags behind V'_1 by 90° . The phasor sum of I'_w and I'_m gives the referred value of no-load current I'_0 . The phasor sum of I'_0 and load current I_2 gives the referred primary current $I'_1 (= I_1/K)$.

Approximate Equivalent Circuit of a Loaded Transformer

The no-load current I_0 in a transformer is only 1-3% of the rated primary current and may be neglected without any serious error. The transformer can then be shown as in Fig. (7.25). This is an approximate representation because no-load current has been neglected. Note that all the circuit elements have been shown external so that the transformer is an ideal one.

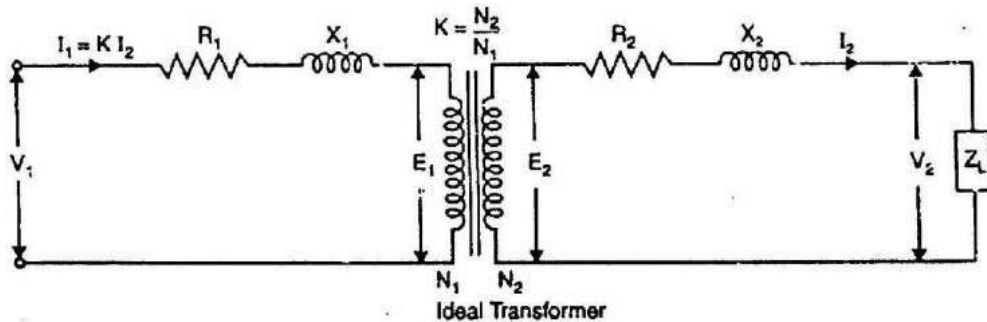

Fig. (7.25)

As shown in Sec. 7.11, if we refer all the quantities to one side (primary or secondary), the ideal transformer stands removed and we get the equivalent circuit.

(i) Equivalent circuit of transformer referred to primary

If all the secondary quantities are referred to the primary, we get the equivalent circuit of the transformer referred to primary as shown in Fig. (7.26). Note that when secondary quantities are referred to primary, resistances/reactances are divided by K^2 , voltages are divided by K and currents are multiplied by K .

The equivalent circuit shown in Fig. (7.26) is an electrical circuit and can be solved for various currents and voltages. Thus if we find V'_2 and I'_2 , then actual secondary values can be determined as under:

$$\text{Actual secondary voltage, } V_2 = K V'_2$$

Actual secondary current, $I_2 = I'_2/K$

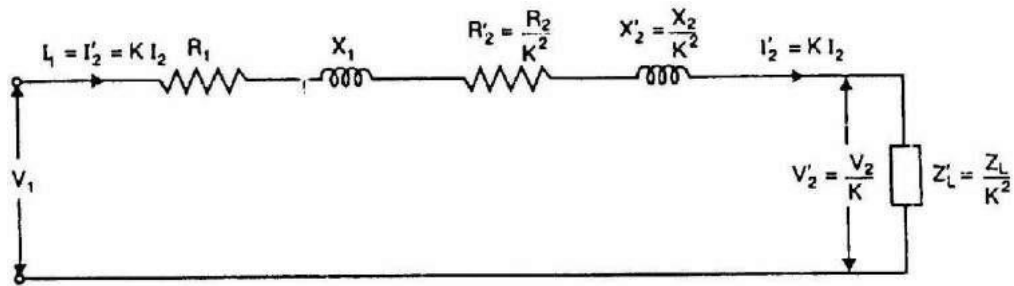

Fig.(7.26)

Equivalent circuit of transformer referred to secondary

If all the primary quantities are referred to secondary, we get the equivalent circuit of the transformer referred to secondary as shown in Fig. (7.27). Note that when primary quantities are referred to secondary, resistances/reactances are multiplied by K^2 , voltages are multiplied by K and currents are divided by K .

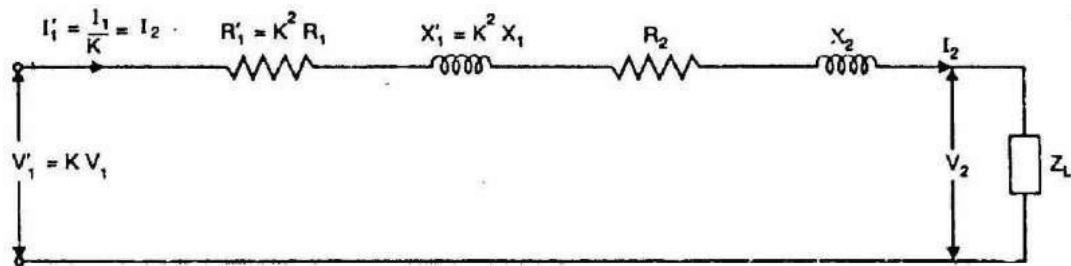

Fig. (7.27)

The equivalent circuit shown in Fig. (7.27) is an electrical circuit and can be solved for various voltages and currents. Thus if we find V'_1 and I'_1 , then actual primary values can be determined as under:

Actual primary voltage, $V_1 = V'_1/K$

Actual primary current, $I_1 = KI'_1$

Note: The same final answers will be obtained whether we use the equivalent circuit referred to primary or secondary. The use of a particular equivalent circuit would depend upon the conditions of the problem.

Transformer Tests

The circuit constants, efficiency and voltage regulation of a transformer can be determined by two simple tests (i) open-circuit test and (ii) short-circuit test. These tests are very convenient as they provide the required information without actually loading the transformer. Further, the power required to carry out these tests is very small as compared with full-load output of the transformer. These tests consist of measuring the input voltage, current and power to the primary first with secondary open-circuited (open-circuit test) and then with the secondary short-circuited (short circuit test).

Open-Circuit or No-Load Test

This test is conducted to determine the iron losses (or core losses) and parameters R_0 and X_0 of the transformer. In this test, the rated voltage is applied to the primary (usually low-voltage winding) while the secondary is left open-circuited. The applied primary voltage V_1 is measured by the voltmeter, the no-load current I_0 by ammeter and no-load input power W_0 by wattmeter as shown in Fig. (7.30 (i)). As the normal rated voltage is applied to the primary, therefore, normal iron losses will occur in the transformer core. Hence wattmeter will record the iron losses and small copper loss in the primary. Since no-load current I_0 is very small (usually 2-10 % of rated current). Cu losses in the primary under no-load condition are negligible as compared with iron losses. Hence, wattmeter reading practically gives the iron losses in the transformer. It is reminded that iron losses are the same at all loads. Fig. (7.30 (ii)) shows the equivalent circuit of transformer on no-load.

$$\begin{aligned} \text{Iron losses, } P_i &= \text{Wattmeter reading} = W_0 \\ \text{No load current} &= \text{Ammeter reading} = I_0 \\ \text{Applied voltage} &= \text{Voltmeter reading} = V_1 \\ \text{Input power, } W_0 &= V_1 I_0 \cos \phi_0 \end{aligned}$$

$$I_W = I_0 \cos \phi_0; \quad I_m = I_0 \sin \phi_0$$

$$R_0 = \frac{V_1}{I_W} \quad \text{and} \quad X_0 = \frac{V_1}{I_m}$$

Thus open-circuit test enables us to determine iron losses and parameters R_0 and X_0 of the transformer.

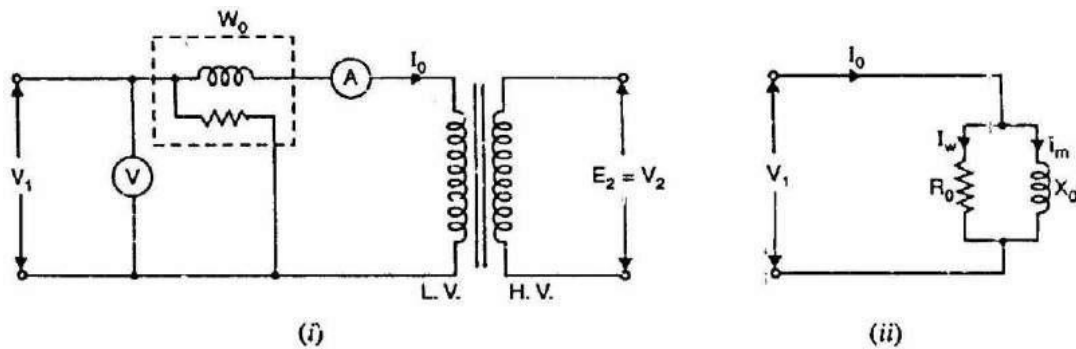
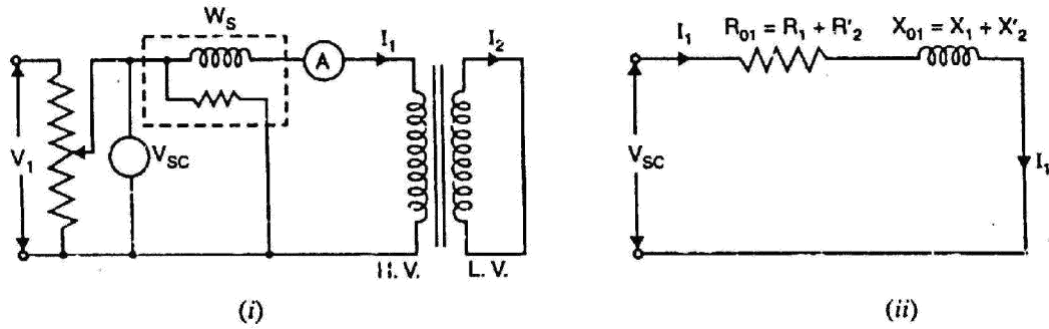

Fig.(7.30)

Short-Circuit or Impedance Test

This test is conducted to determine R_{01} (or R_{02}), X_{01} (or X_{02}) and full-load copper losses of the transformer. In this test, the secondary (usually low-voltage winding) is short-circuited by a thick conductor and variable low voltage is applied to the primary as shown in Fig. (7.31 (i)). The low input voltage is gradually raised till at voltage V_{SC} , full-load current I_1 flows in the primary. Then I_2 in the secondary also has full-load value since $I_1/I_2 = N_2/N_1$. Under such conditions, the copper loss in the windings is the same as that on full load.

There is no output from the transformer under short-circuit conditions. Therefore, input power is all loss and this loss is almost entirely copper loss. It is because iron loss in the core is negligibly small since the voltage V_{SC} is very small. Hence, the wattmeter will practically register the full-load copper losses in the transformer windings. Fig. (7.31 (ii)) shows the equivalent circuit of a transformer on short circuit as referred to primary; the no-load current being neglected due to its smallness.



$$P_C = I_1^2 R_1 + I_1^2 R'_2 = I_1^2 R_{01}$$

$$\therefore R_{01} = \frac{P_C}{I_1^2}$$

where R_{01} is the total resistance of transformer referred to primary.

$$\text{Total impedance referred to primary, } Z_{01} = \frac{V_{SC}}{I_1}$$

$$\text{Total leakage reactance referred to primary, } X_{01} = \sqrt{Z_{01}^2 - R_{01}^2}$$

$$\text{Short-circuit p.f, } \cos \phi_2 = \frac{P_C}{V_{SC} I_1}$$

Thus short-circuit test gives full-load Cu loss, R_{01} and X_{01} .

Note: The short-circuit test will give full-load Cu loss only if the applied voltage V_{SC} is such so as to circulate full-load currents in the windings. If in a short-circuit test, current value is other than full-load value, the Cu loss will be corresponding to that current value.

Advantages of Transformer Tests

The above two simple transformer tests offer the following advantages:

The power required to carry out these tests is very small as compared to the full-load output of the transformer. In case of open-circuit test, power required is equal to the iron loss whereas for a short-circuit test, power required is equal to full-load copper loss.

These tests enable us to determine the efficiency of the transformer accurately at any load and p.f. without actually loading the transformer.

The short-circuit test enables us to determine R_{01} and X_{01} (or R_{02} and X_{02}). We can thus find the total voltage drop in the transformer as

referred to primary or secondary. This permits us to calculate voltage regulation of the transformer.

Losses in a Transformer

The power losses in a transformer are of two types, namely;

1. Core or Iron losses
2. Copper losses

These losses appear in the form of heat and produce (i) an increase in temperature and (ii) a drop in efficiency.

Core or Iron losses (P_i)

These consist of hysteresis and eddy current losses and occur in the transformer core due to the alternating flux. These can be determined by open-circuit test.

$$\text{Hysteresis loss, } = k_h f B_m^{1.6} \quad \text{watts / m}^3$$

$$\text{Eddy current loss, } = k_e f^2 B_m^2 t^2 \quad \text{watts / m}^3$$

Both hysteresis and eddy current losses depend upon (i) maximum flux density B_m in the core and (ii) supply frequency f . Since transformers are connected to constant-frequency, constant voltage supply, both f and B_m are constant. Hence, core or iron losses are practically the same at all loads.

$$\text{Iron or Core losses, } P_i = \text{Hysteresis loss} + \text{Eddy current loss} = \\ \text{Constant losses}$$

The hysteresis loss can be minimized by using steel of high silicon content whereas eddy current loss can be reduced by using core of thin laminations.

Copper losses

These losses occur in both the primary and secondary windings due to their ohmic resistance. These can be determined by short-circuit test.

$$I^2 R_{01} \text{ or } I^2 R_{02}$$

It is clear that copper losses vary as the square of load current. Thus if copper losses are 400 W at a load current of 10 A, then they will be $(1/2)^2 \cdot 400 = 100$ W at a load current of 5A.

$$\begin{aligned} \text{Total losses in a transformer} &= P_1 + P_C \\ &= \text{Constant losses} + \text{Variable losses} \end{aligned}$$

It may be noted that in a transformer, copper losses account for about 90% of the total losses.

Efficiency of a Transformer

Like any other electrical machine, the efficiency of a transformer is defined as the ratio of output power (in watts or kW) to input power (watts or kW) i.e.,

$$\text{Efficiency} = \frac{\text{Output power}}{\text{Input power}}$$

It may appear that efficiency can be determined by directly loading the transformer and measuring the input power and output power. However, this method has the following drawbacks:

Since the efficiency of a transformer is very high, even 1% error in each wattmeter (output and input) may give ridiculous results. This test, for instance, may give efficiency higher than 100%.

Since the test is performed with transformer on load, considerable amount of power is wasted.

For large transformers, the cost of power alone would be considerable.

It is generally difficult to have a device that is capable of absorbing all of the output power.

The test gives no information about the proportion of various losses.

Due to these drawbacks, direct loading method is seldom used to determine the efficiency of a transformer. In practice, open-circuit and short-circuit tests are carried out to find the efficiency.

$$\text{Efficiency} = \frac{\text{Output}}{\text{Input} + \text{Output} + \text{Losses}}$$

Losses The losses can be determined by transformer tests.

Construction of a Transformer

We usually design a power transformer so that it approaches the characteristics of an ideal transformer. To achieve this, following design features are incorporated:

The core is made of silicon steel which has low hysteresis loss and high permeability.

Further, core is laminated in order to reduce eddy current loss. These features considerably reduce the iron losses and the no-load current.

Instead of placing primary on one limb and secondary on the other, it is a usual practice to wind one-half of each winding on one limb. This ensures tight coupling between the two windings. Consequently, leakage flux is considerably reduced.

The winding resistances R_1 and R_2 are minimized to reduce I^2R loss and resulting rise in temperature and to ensure high efficiency.

Types of Transformers

Depending upon the manner in which the primary and secondary are wound on the core, transformers are of two types viz., (i) core-type transformer and (ii) shell-type transformer.

Core-type transformer. In a core-type transformer, half of the primary winding and half of the secondary winding are placed round each limb as shown in Fig. (7.34). This reduces the leakage flux. It is a usual practice to place the low-voltage winding below the high-voltage winding for mechanical considerations.

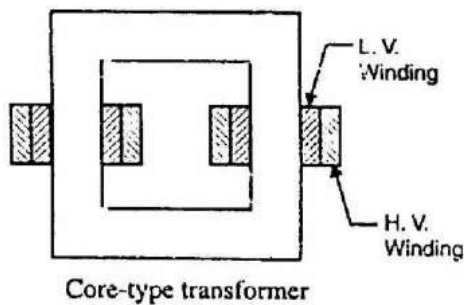

Fig.(7.34)

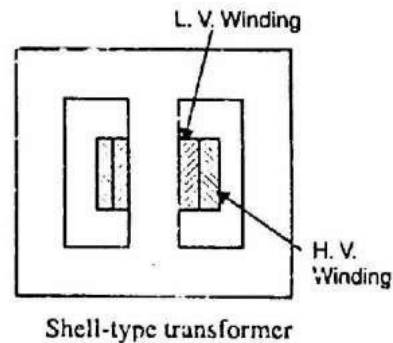

Fig.(7.35)

Shell-type transformer. This method of construction involves the use of a double magnetic circuit. Both the windings are placed round the central limb (See Fig. 7.35), the other two limbs acting simply as a low-reluctance flux path.

The choice of type (whether core or shell) will not greatly affect the efficiency of the transformer. The core type is generally more suitable for high voltage and small output while the shell-type is generally more suitable for low voltage and high output.

Cooling of Transformers

In all electrical machines, the losses produce heat and means must be provided to keep the temperature low. In generators and motors, the rotating unit serves as a fan causing air to circulate and carry away the heat. However, a transformer has no rotating parts. Therefore, some other methods of cooling must be used. Heat is produced in a transformer by the iron losses in the core and I^2R loss in the windings. To prevent undue temperature rise, this heat is removed by cooling.

In small transformers (below 50 kVA), natural air cooling is employed i.e., the heat produced is carried away by the surrounding air.

Medium size power or distribution transformers are generally cooled by housing them in tanks filled with oil. The oil serves a double purpose, carrying the heat from the windings to the surface of the tank and insulating the primary from the secondary.

For large transformers, external radiators are added to increase the cooling surface of the oil filled tank. The oil circulates around the transformer and moves through the radiators where the heat is released to surrounding air. Sometimes cooling fans blow air over the radiators to accelerate the cooling process.

Autotransformer

An autotransformer has a single winding on an iron core and a part of winding is common to both the primary and secondary circuits. Fig. (7.36 (i)) shows the connections of a step-down autotransformer whereas Fig. (7.36 (ii)) shows the connections of a step-up autotransformer. In either case, the winding ab having N_1 turns is the primary winding and winding bc having N_2 turns is the secondary winding. Note that the primary and secondary windings are connected electrically as well as magnetically. Therefore, power from the primary is transferred to the secondary conductively as well as inductively (transformer action). The voltage transformation ratio K of an ideal autotransformer is

$$K = \frac{V_2}{V_1} = \frac{N_2}{N_1} = \frac{I_1}{I_2}$$

Note that in an autotransformer, secondary and primary voltages are related in the same way as in a 2-winding transformer.

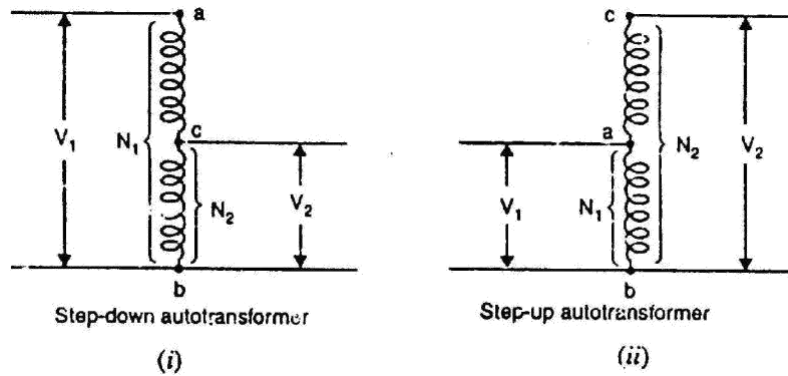

Fig.(7.36)

Fig. (7.37) shows the connections of a loaded step-down as well as step-up autotransformer. In each case, I_1 is the input current and I_2 is the output or load current. Regardless of autotransformer connection (step-up or step-down), the current in the portion of the winding that is common to both the primary and the secondary is the difference between these currents (I_1 and I_2). The relative direction of the current through the common portion of the winding depends upon the connections of the autotransformer. It is because the type of connection determines whether input current I_1 or output current I_2 is larger. For step-down autotransformer $I_2 > I_1$ (as for 2-winding transformer) so that $I_2 - I_1$ current flows through the common portion of the winding. For step-up autotransformer, $I_2 < I_1$. Therefore, $I_1 - I_2$ current flows in the common portion of the winding.

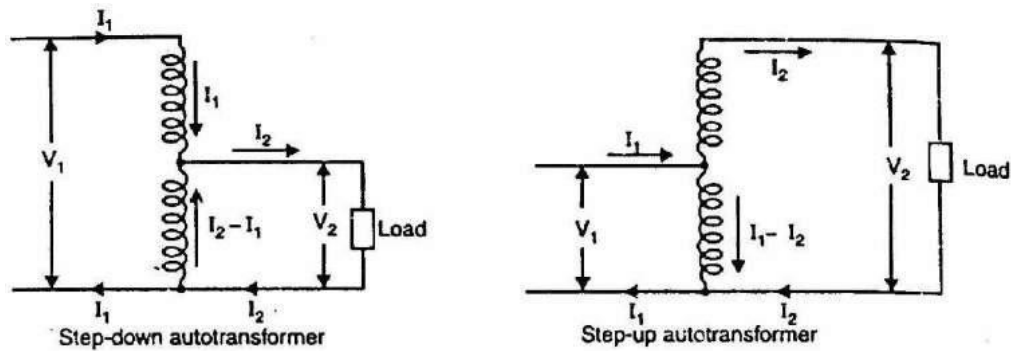

Fig.(7.37)

In an ideal autotransformer, exciting current and losses are neglected. For such an autotransformer, as K approaches 1, the value of current in the common portion ($I_2 - I_1$ or $I_1 - I_2$) of the winding approaches zero. Therefore, for value of K near unity, the common portion of the winding can be wound with wire of smaller cross-sectional area. For this reason, an autotransformer requires less copper.

Theory of Autotransformer

Fig. (7.38 (i)) shows an ideal step-down autotransformer on load. Here winding 1-3 having N_1 turns is the primary winding while winding 2-3 having N_2 turns is the secondary winding. The input current is I_1 while the output or load current is I_2 . Note that portion 1-2 of the winding has $N_1 - N_2$ turns and voltage across this portion of the winding is $V_1 - V_2$. The current through the common portion of the winding is $I_2 - I_1$.

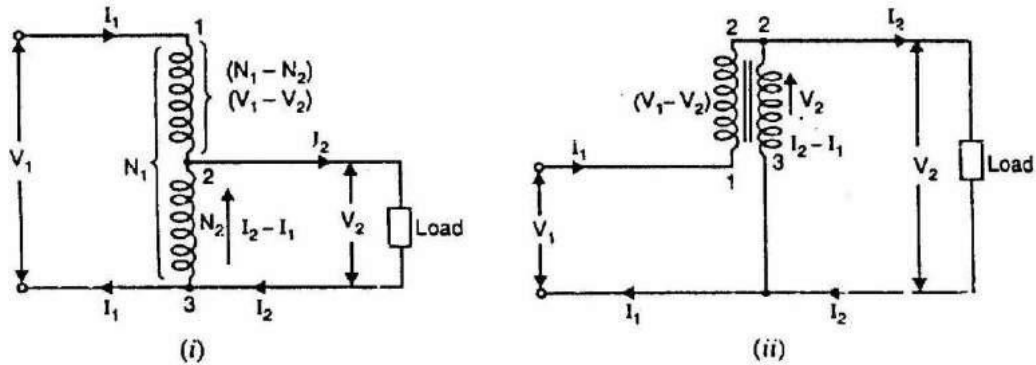

Fig.(7.38)

Fig. (7.38 (ii)) shows the equivalent circuit of the autotransformer. From this equivalent circuit, we have,

$$\frac{V_2}{V_1 - V_2} = \frac{N_2}{N_1 - N_2}$$

$$V_2(N_1 - N_2) = N_2(V_1 - V_2)$$

or $V_2N_1 - V_2N_2 = N_2V_1 - N_2V_2$

or $V_2N_1 = N_2V_1$

$$\therefore \frac{V_2}{V_1} = \frac{N_2}{N_1} = K$$

Also

or

or

$$\therefore \frac{V_2}{V_1} = \frac{I_1}{I_2}$$

Advantages and Disadvantages of autotransformers Advantages

An autotransformer requires less Cu than a two-winding transformer of similar rating.

An autotransformer operates at a higher efficiency than a two-winding transformer of similar rating.

An autotransformer has better voltage regulation than a two-winding transformer of the same rating.

An autotransformer has smaller size than a two-winding transformer of the same rating.

An autotransformer requires smaller exciting current than a two-winding transformer of the same rating.

It may be noted that these advantages of the autotransformer decrease as the ratio of transformation increases. Therefore, an autotransformer has marked

advantages only for relatively low values of transformation ratio (i.e. values approaching 1).

Disadvantages

There is a direct connection between the primary and secondary. Therefore, the output is no longer d.c. isolated from the input.

An autotransformer is not safe for stepping down a high voltage to a low voltage. As an illustration, Fig. (7.40)

shows 11000/230 V step-down

autotransformer. If an open circuit

develops in the common portion 2-3 of the winding, then full-primary voltage (i.e.,

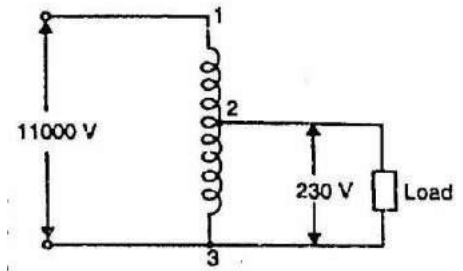

Fig.(7-40)

11000 V in this case) will appear across the load. In such a case, any one coming in contact with the secondary is subjected to high voltage. This could be dangerous to both the persons and equipment. For this reason, autotransformers are prohibited for general use.

The short-circuit current is much larger than for the two-winding transformer of the same rating. It can be seen from Fig. (7.40) that a short-circuited secondary causes part of the primary also to be short-circuited. This reduces the effective resistance and reactance.

Applications of Autotransformers

Autotransformers are used to compensate for voltage drops in transmission and distribution lines. When used for this purpose, they are known as booster transformers.

Autotransformers are used for reducing the voltage supplied to a.c. motors during the starting period.

Autotransformers are used for continuously variable supply.

Chapter (6)

Induction Motors

Introduction

The three-phase induction motors are the most widely used electric motors in industry. They run at essentially constant speed from no-load to full-load. However, the speed is frequency dependent and consequently these motors are not easily adapted to speed control. We usually prefer d.c. motors when large speed variations are required. Nevertheless, the 3-phase induction motors are simple, rugged, low-priced, easy to maintain and can be manufactured with characteristics to suit most industrial requirements. In this chapter, we shall focus our attention on the general principles of 3-phase induction motors.

Three-Phase Induction Motor

Like any electric motor, a 3-phase induction motor has a stator and a rotor. The stator carries a 3-phase winding (called stator winding) while the rotor carries a short-circuited winding (called rotor winding). Only the stator winding is fed from 3-phase supply. The rotor winding derives its voltage and power from the externally energized stator winding through electromagnetic induction and hence the name. The induction motor may be considered to be a transformer with a rotating secondary and it can, therefore, be described as a “transformer-type” a.c. machine in which electrical energy is converted into mechanical energy.

Advantages

- It has simple and rugged construction.
- It is relatively cheap.
- It requires little maintenance.
- It has high efficiency and reasonably good power factor.
- It has self starting torque.

Disadvantages

- It is essentially a constant speed motor and its speed cannot be changed easily.
- Its starting torque is inferior to d.c. shunt motor.

8.2 Construction

A 3-phase induction motor has two main parts (i) stator and (ii) rotor. The rotor is separated from the stator by a small air-gap which ranges from 0.4 mm to 4 mm, depending on the power of the motor.

1. Stator

It consists of a steel frame which encloses a hollow, cylindrical core made up of thin laminations of silicon steel to reduce hysteresis and eddy current losses. A number of evenly spaced slots are provided on the inner periphery of the laminations [See Fig. (8.1)]. The insulated connected to form a

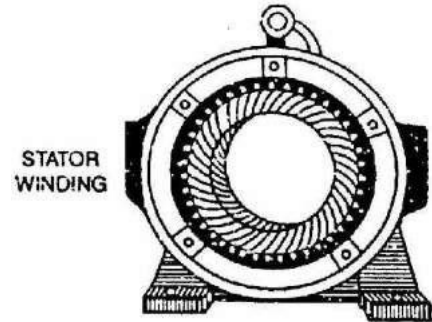

Fig.(8.1)

balanced 3-phase star or delta connected

circuit. The 3-phase stator winding is wound for a definite number of poles as per requirement of speed. Greater the number of poles, lesser is the speed of the motor and vice-versa. When 3-phase supply is given to the stator winding, a rotating magnetic field (See Sec. 8.3) of constant magnitude is produced. This rotating field induces currents in the rotor by electromagnetic induction.

Rotor

The rotor, mounted on a shaft, is a hollow laminated core having slots on its outer periphery. The winding placed in these slots (called rotor winding) may be one of the following two types:

- (i) Squirrel cage type
- (ii) Wound type

Squirrel cage rotor. It consists of a laminated cylindrical core having parallel slots on its outer periphery. One copper or aluminum bar is placed in each slot. All these bars are joined at each end by metal rings called end rings [See Fig. (8.2)]. This forms a permanently short-circuited winding which is indestructible. The entire construction (bars and end rings) resembles a squirrel cage and hence the name. The rotor is not connected electrically to the supply but has current induced in it by transformer action from the stator.

Those induction motors which employ squirrel cage rotor are called squirrel cage induction motors. Most of 3-phase induction motors use squirrel cage rotor as it has a remarkably simple and robust construction enabling it to operate in the most adverse circumstances. However, it suffers from the disadvantage of a low starting torque. It is because the rotor bars are permanently short-circuited and it is not possible to add any external resistance to the rotor circuit to have a large starting torque.

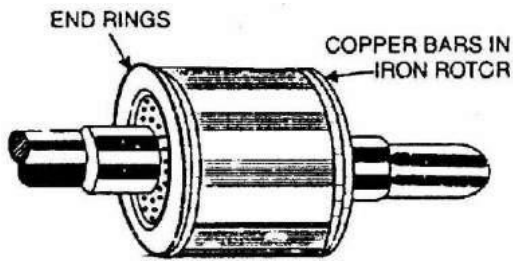

Fig.(8.2)

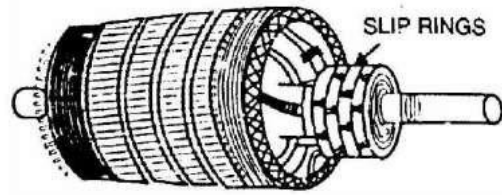

Fig.(8.3)

Wound rotor. It consists of a laminated cylindrical core and carries a 3-phase winding, similar to the one on the stator [See Fig. (8.3)]. The rotor winding is uniformly distributed in the slots and is usually star-connected. The open ends of the rotor winding are brought out and joined to three insulated slip rings mounted on the rotor shaft with one brush resting on each slip ring. The three brushes are connected to a 3-phase star-connected rheostat as shown in Fig. (8.4). At starting, the external resistances are included in the rotor circuit to give a large starting torque. These resistances are gradually reduced to zero as the motor runs up to speed.

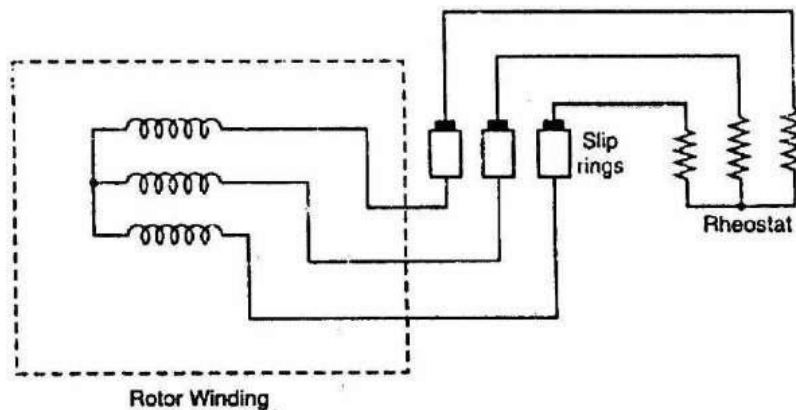

Fig.(8.4)

The external resistances are used during starting period only. When the motor attains normal speed, the three brushes are short-circuited so that the wound rotor runs like a squirrel cage rotor.

Rotating Magnetic Field Due to 3-Phase Currents

When a 3-phase winding is energized from a 3-phase supply, a rotating magnetic field is produced. This field is such that its poles do not remain in a fixed position on the stator but go on shifting their positions around the stator. For this reason, it is called a rotating field. It can be shown that magnitude of this rotating field is constant and is equal to $1.5 \phi_m$ where ϕ_m is the maximum flux due to any phase.

To see how rotating field is produced, consider a 2-pole, 3-phase winding as shown in Fig. (8.6 (i)). The three phases X, Y and Z are energized from a 3-phase source and currents in these phases are indicated as I_x , I_y and I_z [See Fig. (8.6 (ii))]. Referring to Fig. (8.6 (ii)), the fluxes produced by these currents are given by:

$$\begin{aligned} \phi_x &= \phi_m \sin \omega t \\ \phi_y &= \phi_m \sin (\omega t - 120^\circ) \\ \phi_z &= \phi_m \sin (\omega t - 240^\circ) \end{aligned}$$

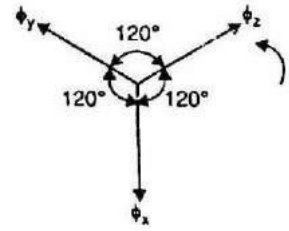

Fig.(8.5)

Here ϕ_m is the maximum flux due to any phase. Fig. (8.5) shows the phasor diagram of the three fluxes. We shall now prove that this 3-phase supply produces a rotating field of constant magnitude equal to $1.5 \phi_m$.

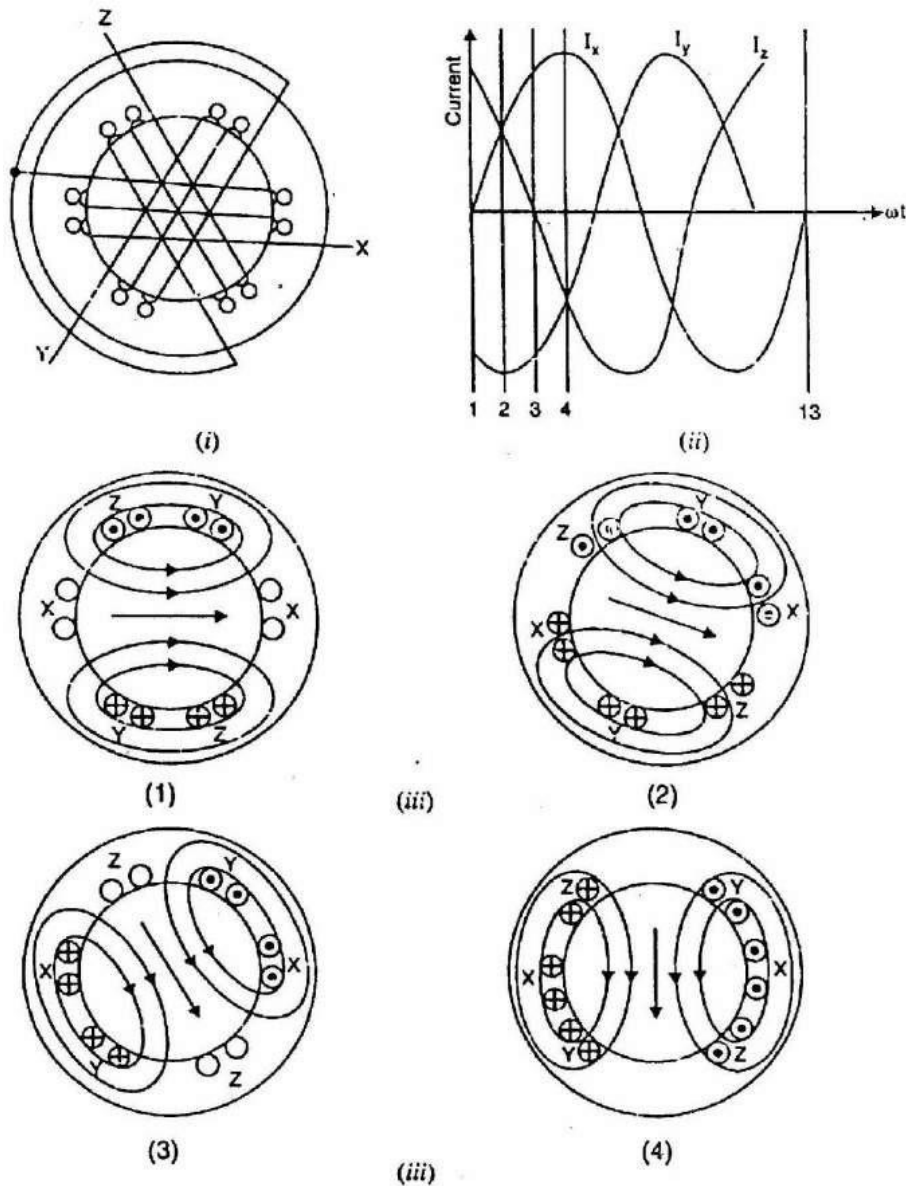
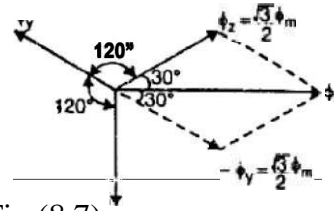

Fig.(8.6)

- (i) At instant 1 [See Fig. (8.6 (ii)) and Fig. (8.6 (iii))], the current in phase X is zero and currents in phases Y and Z are equal and opposite. The currents are flowing outward in the top conductors and inward in the bottom conductors. This establishes a resultant flux towards right. The magnitude of the resultant flux is constant and is equal to $1.5 \phi_m$ as proved under:



i,- o Fig.(8.7)

At instant 1, at $\omega t = 0^\circ$
 Therefore,
 the three fluxes are given by;

$$\phi_x = 0; \quad \phi_y = \phi_m \sin(-120^\circ) = -\frac{\sqrt{3}}{2} \phi_m;$$

$$\phi_z = \phi_m \sin(-240^\circ) = \frac{\sqrt{3}}{2} \phi_m$$

The phasor sum of ϕ_y and ϕ_z is the resultant flux ϕ_r [See Fig. (8.7)]. It is clear that:

- (ii) At instant 2, the current is maximum (negative) in phase Y and 0.5 (positive) in phases X and Z. The magnitude of resultant flux is 1.5 as

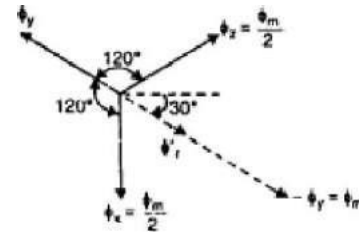

Fig.(8.8)

At instant 2, $\omega t = 30^\circ$. Therefore, the three fluxes are given by;

$$\phi_x = \phi_m \sin 30^\circ = \frac{\phi_m}{2}$$

$$\phi_y = \phi_m \sin(-210^\circ) = -\phi_m$$

The phasor sum of ϕ_x , ϕ_y and ϕ_z is the resultant flux ϕ_r

$$\text{Phasor sum of } \phi_x \text{ and } \phi_z = 2 \times \frac{\phi_m}{2} \cos 120^\circ = \phi_m$$

$$\text{Phasor sum of } \phi_x \text{ and } -\phi_y = \frac{\phi_m}{2} + \phi_m = 1.5 \phi_m$$

Note that resultant flux is displaced 30° clockwise from position 1.

At instant 3, current in phase Z is zero and the currents in phases X and Y are equal and opposite (currents in phases X and Y are $0.866 \bar{m}$ ax. value). The magnitude of resultant flux is $1.5 \phi_m$ as proved under:

At instant 3, $\omega t = 60^\circ$. Therefore, the three fluxes are given by;

At instant 3, $\omega t = 60^\circ$. Therefore, the three fluxes are given by;

$$\phi_x = \phi_m \sin 60^\circ = \frac{\sqrt{3}}{2} \phi_m;$$

$$\phi_y = \phi_m \sin(-60^\circ) = -\frac{\sqrt{3}}{2} \phi_m;$$

$$\phi_z = \phi_m \sin(-180^\circ) = 0$$

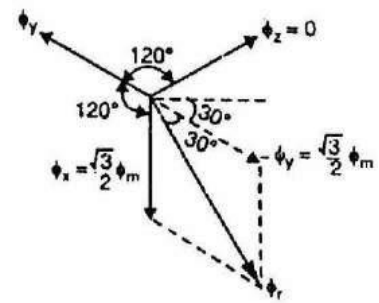

The resultant flux ϕ_r is the phasor sum of ϕ_x and $-\phi_y$ ($\because \phi_z = 0$).

$$\phi_r = 2 \times \frac{\sqrt{3}}{2} \phi_m \cos \frac{60^\circ}{2} = 1.5 \phi_m$$

Note that resultant flux is displaced 60° clockwise from position 1.

- (iv) At instant 4, the current in phase X is maximum (positive) and the currents in phases Y and Z are equal and negative (currents in phases Y and Z are $0.5 \times \text{max. value}$). This establishes a resultant flux downward as shown under:

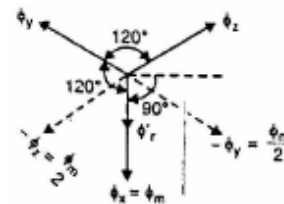

Fig.(7.10)

At instant 4, $\omega t = 90^\circ$. Therefore, the three fluxes are given by;

$$\phi_x = \phi_m \sin 90^\circ = \phi_m$$

$$\phi_y = \phi_m \sin(-30^\circ) = -\frac{\phi_m}{2}$$

$$\phi_z = \phi_m \sin(-150^\circ) = -\frac{\phi_m}{2}$$

The phasor sum of ϕ_x , $-\phi_y$ and $-\phi_z$ is the resultant flux ϕ_r

$$\text{Phasor sum of } -\phi_y \text{ and } -\phi_z, \phi'_r = 2 \times \frac{\phi_m}{2} \cos \frac{120^\circ}{2} = \frac{\phi_m}{2}$$

$$\text{Phasor sum of } \phi'_r \text{ and } \phi_x, \phi_r = \frac{\phi_m}{2} + \phi_m = 1.5 \phi_m$$

Note that the resultant flux is downward i.e., it is displaced 90° clockwise from position 1.

It follows from the above discussion that a 3-phase supply produces a rotating field of constant value ($= 1.5 \phi_m$, where ϕ_m is the maximum flux due to any phase).

Speed of rotating magnetic field

The speed at which the rotating magnetic field revolves is called the synchronous speed (N_s). Referring to Fig. (8.6 (ii)), the time instant 4 represents the completion of one-quarter cycle of alternating current I_x from the time instant 1. During this one quarter cycle, the field has rotated through 90° . At a time instant represented by 13 or one complete cycle of current I_x from the origin, the field has completed one revolution. Therefore, for a 2-pole stator winding, the field makes one revolution in one cycle of current. In a 4-pole stator winding, it can be shown that the rotating field makes one revolution in two cycles of current. In general, for P poles, the rotating field makes one revolution in $P/2$ cycles of current.

$$\phi \text{ Cycles of current} = \frac{P}{2} \phi \text{ revolutions of field}$$

Direction of rotating magnetic field

The phase sequence of the three-phase voltage applied to the stator winding in Fig. (8.6 (ii)) is X-Y-Z. If this sequence is changed to X-Z-Y, it is observed that direction of rotation of the field is reversed i.e., the field rotates counterclockwise rather than clockwise. However, the number of poles and the speed at which the magnetic field rotates remain unchanged. Thus it is necessary only to change the phase sequence in order to change the direction of rotation of the magnetic field. For a three-phase supply, this can be done by interchanging any two of the three lines. As we shall see, the rotor in a 3-phase induction motor runs in the same direction as the rotating magnetic field. Therefore, the

direction of rotation of a 3-phase induction motor can be reversed by interchanging any two of the three motor supply lines.

Slip

We have seen above that rotor rapidly accelerates in the direction of rotating field. In practice, the rotor can never reach the speed of stator flux. If it did, there would be no relative speed between the stator field and rotor conductors, no induced rotor currents and, therefore, no torque to drive the rotor. The friction and windage would immediately cause the rotor to slow down. Hence, the rotor speed (N) is always less than the stator field speed (N_s). This difference in speed depends upon load on the motor.

The difference between the synchronous speed N_s of the rotating stator field and the actual rotor speed N is called slip. It is usually expressed as a percentage of synchronous speed i.e.,

$$\text{Percentage slip, } s = \frac{N_s - N}{N_s} \times 100$$

N_s

The quantity $N_s - N$ is sometimes called slip speed.

When the rotor is stationary (i.e., $N = 0$), slip, $s = 1$ or 100 %.

In an induction motor, the change in slip from no-load to full-load is hardly 0.1% to 3% so that it is essentially a constant-speed motor.

As the rotor picks up speed, the relative speed between the rotating flux and the rotor decreases. Consequently, the slip s and hence rotor current frequency decreases.

Effect of Slip on The Rotor Circuit

Rotor Current

Fig. (8.14) shows the circuit of a 3-phase induction motor at any slip s . The rotor is assumed to be of wound type and star connected. Note that rotor e.m.f./phase and rotor reactance/phase are $s E_2$ and $s X_2$ respectively. The rotor resistance/phase is R_2 and is independent of frequency and, therefore, does not depend upon slip. Likewise, stator winding values R_1 and X_1 do not depend upon slip.

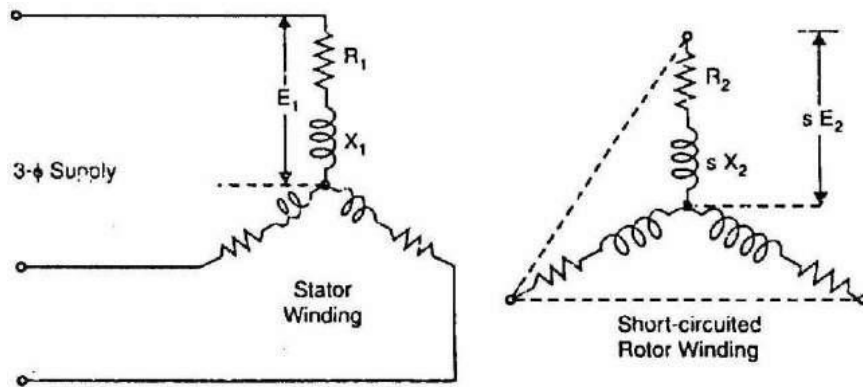

Fig.(8.14)

Since the motor represents a balanced 3-phase load, we need consider one phase only; the conditions in the other two phases being similar.

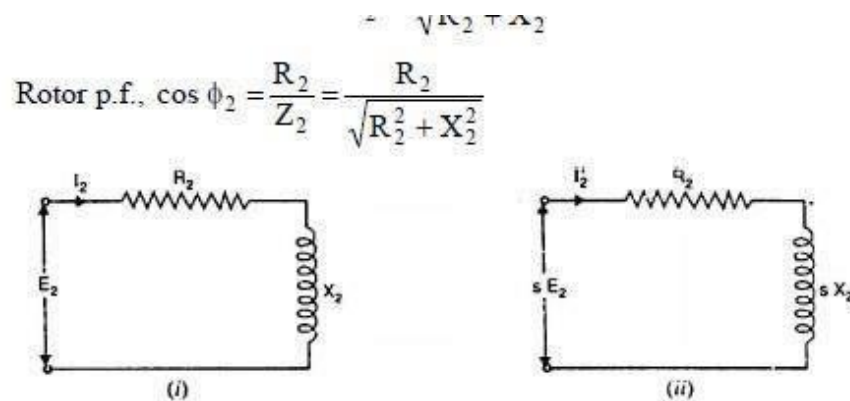

Fig.(8.15)

When running at slip s . Fig. (8.15 (ii)) shows one phase of the rotor circuit when the motor is running at slip s .

$$\text{Rotor current, } I'_2 = \frac{sE_2}{Z'_2} = \frac{sE_2}{\sqrt{R_2^2 + (sX_2)^2}}$$

(iz) zotor e.owl.

(ki) powcz factoz ofthe zotor c cuit

$$T \propto E_2 I_2 \cos \phi_2$$

$$T = K E_2 I_2 \cos \phi_2$$

where I_2 = rotor current at standstill
 I_2 = rotor e.m.f. at standstill
 $\cos \phi_2$ = rotor p.f. at standstill

Yon. The values of rotor e.m.f., rotor current and rotor power factor are taken from the open-circuit test.

Starting Torque (T_s)

Let E_2 = rotor e.m.f. per phase at standstill
 X_2 = rotor reactance per phase at standstill

Rotor impedance/phase, $Z_2 = \sqrt{R_2^2 + X_2^2}$.at standstill

Rotor current at standstill, $I_2 = \frac{E_2}{Z_2} = \frac{E_2}{\sqrt{R_2^2 + X_2^2}}$.at standstill

$$T_s = K E_2 I_2 \cos \phi_2$$

$$= K E_2 \times \frac{E_2}{\sqrt{R_2^2 + X_2^2}} \times \frac{R_2}{\sqrt{R_2^2 + X_2^2}}$$

$$= \frac{K E_2^2 R_2}{R_2^2 + X_2^2}$$

Generally, the stator supply voltage V is constant so that flux per pole ϕ set up by the stator is also fixed. This in turn means that e.m.f. E_2 induced in the rotor will be constant.

$$\therefore T_s = \frac{K_1 R_2}{R_2^2 + X_2^2} = \frac{K_1 R_2}{Z_2^2}$$

where K_1 is another constant.

It is clear that the magnitude of starting torque would depend upon the relative values of R_2 and X_2 i.e., rotor resistance/phase and standstill rotor reactance/phase.

It can be shown that $K = 3/2 \pi N_s$.

$$\therefore T_s = \frac{3}{2\pi N_s} \cdot \frac{E_2^2 R_2}{R_2^2 + X_2^2}$$

Note that here N_s is in r.p.s.

Starting Torque of 3-Phase Induction Motors

The rotor circuit of an induction motor has low resistance and high inductance. At starting, the rotor frequency is equal to the stator frequency (i.e., 50 Hz) so that rotor reactance is large compared with rotor resistance. Therefore, rotor current lags the rotor e.m.f. by a large angle, the power factor is low and consequently the starting torque is small. When resistance is added to the rotor circuit, the rotor power factor is improved which results in improved starting torque. This, of course, increases the rotor impedance and, therefore, decreases the value of rotor current but the effect of improved power factor predominates and the starting torque is increased.

Squirrel-cage motors. Since the rotor bars are permanently short-circuited, it is not possible to add any external resistance in the rotor circuit at starting. Consequently, the stalling torque of such motors is low. Squirrel

cage motors have starting torque of 1.5 to 2 times the full-load value with starting current of 5 to 9 times the full-load current.

Wound rotor motors. The resistance of the rotor circuit of such motors can be increased through the addition of external resistance. By inserting the proper value of external resistance (so that $R_2 = X_2$), maximum starting torque can be obtained. As the motor accelerates, the external resistance is gradually cut out until the rotor circuit is short-circuited on itself for running conditions.

Power Relations

The transformer equivalent circuit of an induction motor is quite helpful in analyzing the various power relations in the motor. Fig. (8.28) shows the equivalent circuit per phase of an induction motor where all values have been referred to primary (i.e., stator).

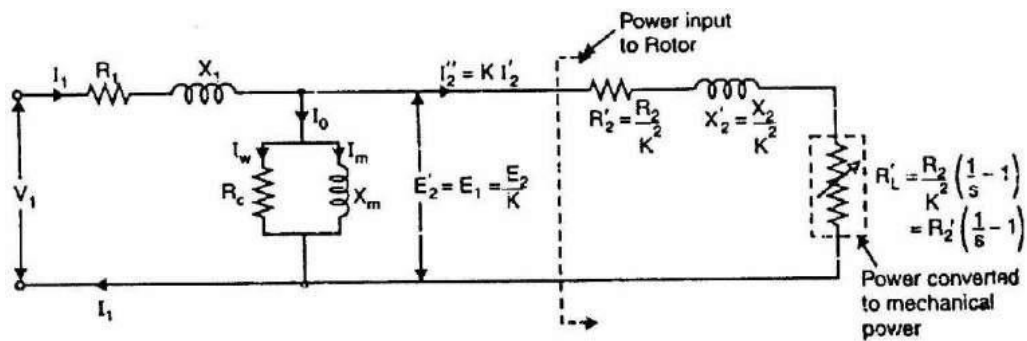

Fig.(8.28)

Approximate Equivalent Circuit of Induction Motor

As in case of a transformer, the approximate equivalent circuit of an induction motor is obtained by shifting the shunt branch ($R_c \square X_m$) to the input terminals as shown in Fig. (8.29). This step has been taken on the assumption that voltage drop in R_1 and X_1 is small and the terminal voltage V_1 does not appreciably differ from the induced voltage E_1 . Fig. (8.29) shows the approximate equivalent circuit per phase of an induction motor where all values have been referred to primary (i.e., stator).

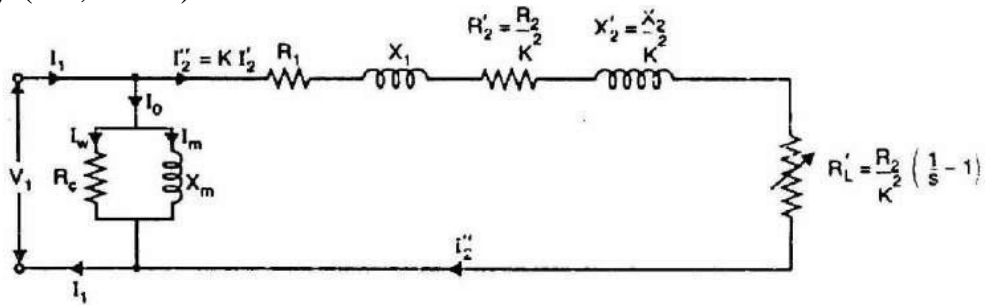

Fig.(8.29)

The above approximate circuit of induction motor is not so readily justified as with the transformer. This is due to the following reasons:

Unlike that of a power transformer, the magnetic circuit of the induction motor has an air-gap. Therefore, the exciting current of induction motor (30 to 40% of full-load current) is much higher than that of the power transformer. Consequently, the exact equivalent circuit must be used for accurate results.

The relative values of X_1 and X_2 in an induction motor are larger than the corresponding ones to be found in the transformer. This fact does not justify the use of approximate equivalent circuit

In a transformer, the windings are concentrated whereas in an induction motor, the windings are distributed. This affects the transformation ratio.

In spite of the above drawbacks of approximate equivalent circuit, it yields results that are satisfactory for large motors. However, approximate equivalent circuit is not justified for small motors.

Starting of 3-Phase Induction Motors

The induction motor is fundamentally a transformer in which the stator is the primary and the rotor is short-circuited secondary. At starting, the voltage induced in the induction motor rotor is maximum ($s = 1$). Since the rotor impedance is low, the rotor current is excessively large. This large rotor current is reflected in the stator because of transformer action. This results in high starting current (4 to 10 times the full-load current) in the stator at low power

factor and consequently the value of starting torque is low. Because of the short duration, this value of large current does not harm the motor if the motor accelerates normally. However, this large starting current will produce large line-voltage drop. This will adversely affect the operation of other electrical equipment connected to the same lines. Therefore, it is desirable and necessary to reduce the magnitude of stator current at starting and several methods are available for this purpose.

Methods of Starting 3-Phase Induction Motors

The method to be employed in starting a given induction motor depends upon the size of the motor and the type of the motor. The common methods used to start induction motors are:

- (i) Direct-on-line starting
- (ii) Stator resistance starting
- (iii) Autotransformer starting
- (iv) Star-delta starting
- (v) Rotor resistance starting

Methods (i) to (iv) are applicable to both squirrel-cage and slip ring motors. However, method (v) is applicable only to slip ring motors. In practice, any one of the first four methods is used for starting squirrel cage motors, depending upon the size of the motor. But slip ring motors are invariably started by rotor resistance starting.

8.36 Methods of Starting Squirrel-Cage Motors

Except direct-on-line starting, all other methods of starting squirrel-cage motors employ reduced voltage across motor terminals at starting.

(i) Direct-on-line starting

This method of starting is just what the name implies—the motor is started by connecting it directly to 3-phase supply. The impedance of the motor at standstill is relatively low and when it is directly connected to the supply system, the starting current will be high (4 to 10 times the full-load current) and at a low power factor. Consequently, this method of starting is suitable for relatively small (up to 7.5 kW) machines.

Relation between starting and F.L. torques. We know that:

$$\text{Rotor input} = 2\pi N_s T = kT$$

But $\text{Rotor Cu loss} = s \times \text{Rotor input}$

$$\therefore 3(I_2')^2 R_2 = s \times kT$$

or $T \propto (I_2')^2 / s$

or $T \propto I_1^2/s$ ($\because I_2 \propto I_1$)

If I_{st} is the starting current, then starting torque (T_{st}) is

$$T \propto I_{st}^2 \quad (\because \text{at starting } s = 1)$$

If I_f is the full-load current and s_f is the full-load slip, then,

$$T_f \propto I_f^2/s_f$$

$$\therefore \frac{T_{st}}{T_f} = \left(\frac{I_{st}}{I_f}\right)^2 \times s_f$$

When the motor is started direct-on-line, the starting current is the short-circuit (blocked-rotor) current I_{sc} .

$$\therefore \frac{T_{st}}{T_f} = \left(\frac{I_{sc}}{I_f}\right)^2 \times s_f$$

Let us illustrate the above relation with a numerical example. Suppose $I_{sc} = 5 I_f$ and full-load slip $s_f = 0.04$. Then,

$$\frac{T_{st}}{T_f} = \left(\frac{I_{sc}}{I_f}\right)^2 \times s_f = \left(\frac{5 I_f}{I_f}\right)^2 \times 0.04 = (5)^2 \times 0.04 = 1$$

$$\therefore T_{st} = T_f$$

Note that starting current is as large as five times the full-load current but starting torque is just equal to the full-load torque. Therefore, starting current is very high and the starting torque is comparatively low. If this large starting current flows for a long time, it may overheat the motor and damage the insulation.

(ii) Stator resistance starting

In this method, external resistances are connected in series with each phase of stator winding during starting. This causes voltage drop across the resistances so that voltage available across motor terminals is reduced and hence the starting current. The starting resistances are gradually cut out in steps (two or more steps) from the stator circuit as the motor picks up speed. When the motor attains rated speed, the resistances are completely cut out and full line voltage is applied to the rotor.

This method suffers from two drawbacks. First, the reduced voltage applied to the motor during the starting period lowers the starting torque and hence increases the accelerating time. Secondly, a lot of power is wasted in the starting resistances.

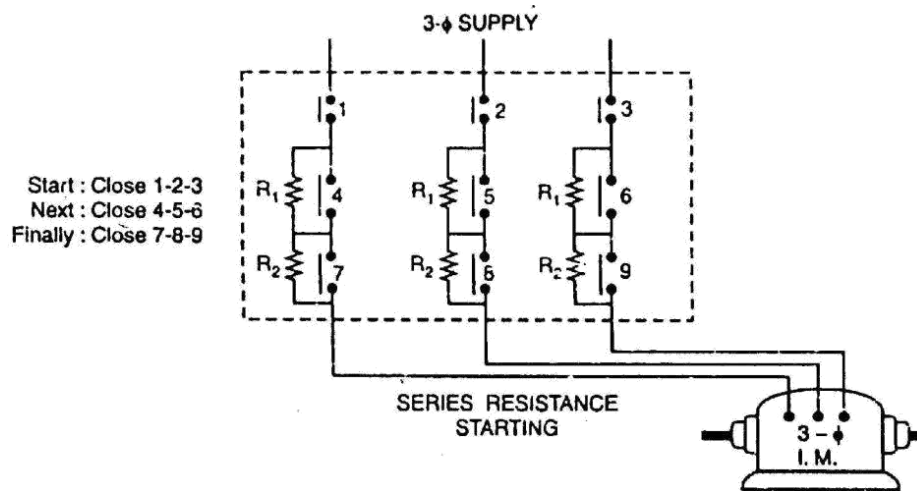

Fig.(8.30)

Relation between starting and F.L. torques. Let V be the rated voltage/phase. If the voltage is reduced by a fraction x by the insertion of resistors in the line, then voltage applied to the motor per phase will be xV .

Thus while the starting current reduces by a fraction x of the rated-voltage

starting current (I_{sc}), the starting torque is reduced by a fraction x^2 of that obtained by direct switching. The reduced voltage applied to the motor during the starting period lowers the starting current but at the same time increases the accelerating time because of the reduced value of the starting torque. Therefore, this method is used for starting small motors only.

(iii) Autotransformer starting

This method also aims at connecting the induction motor to a reduced supply at starting and then connecting it to the full voltage as the motor picks up sufficient speed. Fig. (8.31) shows the circuit arrangement for autotransformer starting. The tapping on the autotransformer is so set that when it is in the circuit, 65% to 80% of line voltage is applied to the motor.

At the instant of starting, the change-over switch is thrown to “start” position. This puts the autotransformer in the circuit and thus reduced voltage is applied to the circuit. Consequently, starting current is limited to safe value. When the motor attains about 80% of normal speed, the changeover switch is thrown to

“run” position. This takes out the autotransformer from the circuit and puts the motor to full line voltage. Autotransformer starting has several advantages viz low power loss, low starting current and less radiated heat. For large machines (over 25 H.P.), this method of starting is often used. This method can be used for both star and delta connected motors.

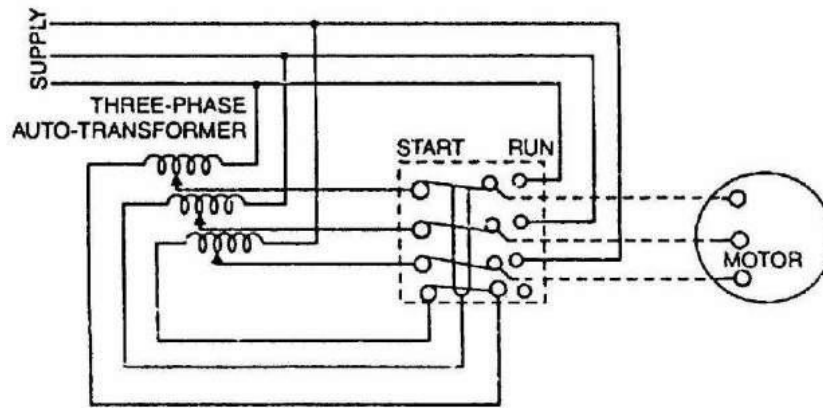

Fig.(8.31)

Relation between starting And F.L. torques. Consider a star-connected squirrel-cage induction motor. If V is the line voltage, then voltage across motor phase on direct switching is $V/\sqrt{3}$ and starting current is $I_{st} = I_{sc}$. In case of autotransformer, if a tapping of transformation ratio K (a fraction) is used, then phase voltage across motor is $KV/\sqrt{3}$ and $I_{st} = K I_{sc}$,

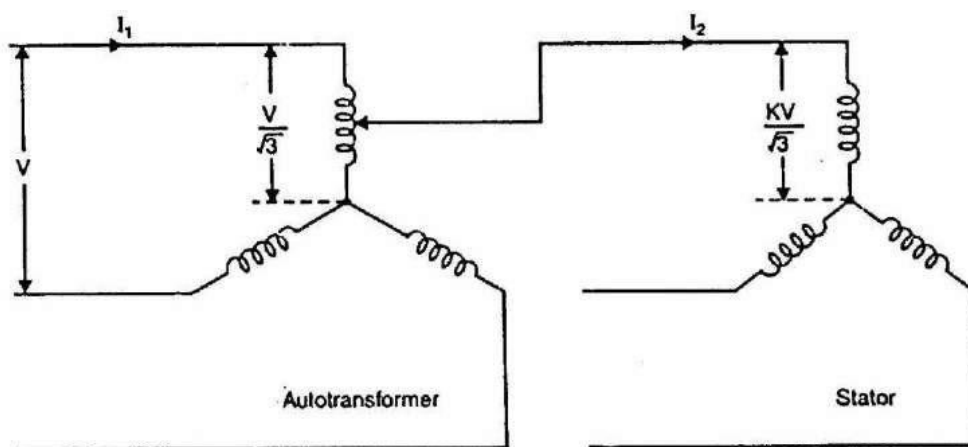

Fig.(8.32)

The current taken from the supply or by autotransformer is $I_1 = KI_2 = K^2 I_{sc}$. Note that motor current is K times, the supply line current is K^2 times and the starting torque is K^2 times the value it would have been on direct-on-line starting.

(iv) Star-delta starting

The stator winding of the motor is designed for delta operation and is connected in star during the starting period. When the machine is up to speed, the connections are changed to delta. The circuit arrangement for star-delta starting is shown in Fig. (8.33).

The six leads of the stator windings are connected to the changeover switch as shown. At the instant of starting, the changeover switch is thrown to "Start" position which connects the stator windings in star. Therefore, each stator phase gets $V/\sqrt{3}$ volts where V is the line voltage. This reduces the starting current.

When the motor picks up speed, the changeover switch is thrown to "Run" position which connects the stator windings in delta. Now each stator phase gets full line voltage V. The disadvantages of this method are:

With star-connection during starting, stator phase voltage is $1/\sqrt{3}$ times the line voltage. Consequently, starting torque is $(1/\sqrt{3})^2$ or 1/3 times the value it would have with D-connection. This is rather a large reduction in starting torque.

The reduction in voltage is fixed.

This method of starting is used for medium-size machines (upto about 25 H.P.)

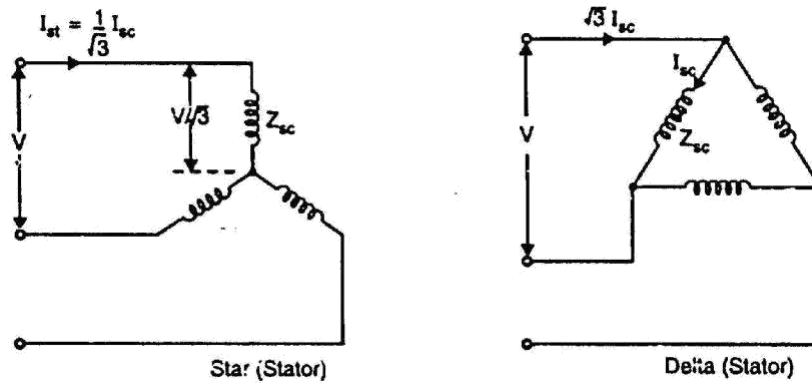

Fig.(8.33)

Note that in star-delta starting, the starting line current is reduced to one-third as compared to starting with the winding delta connected. Further, starting torque is reduced to one-third of that obtainable by direct delta starting. This method is cheap but limited to applications where high starting torque is not necessary e.g., machine tools, pumps etc.

Starting of Slip-Ring Motors

Slip-ring motors are invariably started by rotor resistance starting. In this method, a variable star-connected rheostat is connected in the rotor circuit through slip rings and full voltage is applied to the stator winding as shown in Fig. (8.34).

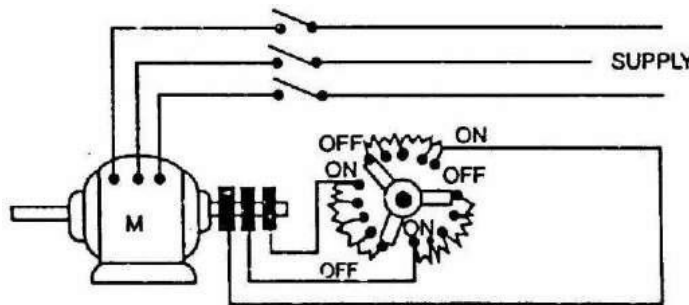

Fig.(8.34)

At starting, the handle of rheostat is set in the OFF position so that maximum resistance is placed in each phase of the rotor circuit. This reduces the starting current and at the same time starting torque is increased.

As the motor picks up speed, the handle of rheostat is gradually moved in clockwise direction and cuts out the external resistance in each phase of the rotor circuit. When the motor attains normal speed, the change-over switch is in the ON position and the whole external resistance is cut out from the rotor circuit.

Chapter (7)

Single-Phase Motors

Introduction

As the name suggests, these motors are used on single-phase supply. Single-phase motors are the most familiar of all electric motors because they are extensively used in home appliances, shops, offices etc. It is true that single-phase motors are less efficient substitute for 3-phase motors but 3-phase power is normally not available except in large commercial and industrial establishments. Since electric power was originally generated and distributed for lighting only, millions of homes were given single-phase supply. This led to the development of single-phase motors. Even where 3-phase mains are present, the single-phase supply may be obtained by using one of the three lines and the neutral. In this chapter, we shall focus our attention on the construction, working and characteristics of commonly used single-phase motors.

Types of Single-Phase Motors

Single-phase motors are generally built in the fractional-horsepower range and may be classified into the following four basic types:

Single-phase induction motors

- (i) split-phase type
- (ii) capacitor type
- 0 shaded-pole type

A.C. series motor or universal motor

Repulsion motors

- 0 Repulsion-start induction-run motor
- 1 Repulsion-induction motor

Synchronous motors

- (i) Reluctance motor
- (ii) Hysteresis motor

Single-Phase Induction Motors

A single phase induction motor is very similar to a 3-phase squirrel cage induction motor. It has (i) a squirrel-cage rotor identical to a 3-phase motor and (ii) a single-phase winding on the stator.

Unlike a 3-phase induction motor, a single-phase induction motor is not self-starting but requires some starting means. The single-phase stator winding produces a magnetic field that pulsates in strength in a sinusoidal manner. The field polarity reverses after each half cycle but the field does not rotate. Consequently, the alternating flux cannot produce rotation in a stationary squirrel-cage rotor. However, if the rotor of a single-phase motor is rotated in one direction by some mechanical means, it will continue to run in the direction of rotation. As a matter of fact, the rotor quickly accelerates until it reaches a speed slightly below the synchronous speed. Once the motor is running at this speed, it will continue to rotate even though single-phase current is flowing through the stator winding. This method of starting is generally not convenient for large motors. Nor can it be employed for a motor located at some inaccessible spot.

Fig. (9.1) shows single-phase induction motor having a squirrel cage rotor and a single-phase distributed stator winding. Such a motor inherently does not develop any starting torque and, therefore, will not start to rotate if the stator winding is connected to single-phase a.c. supply. However, if the rotor is started by auxiliary means, the motor

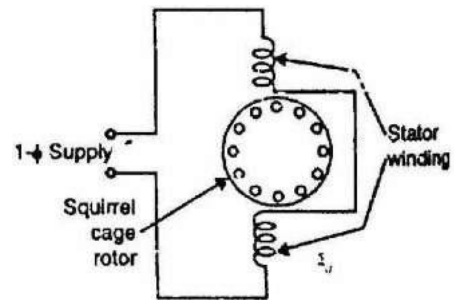

Fig.(9.1)

will quickly attain the final speed. This strange behaviour of single-phase induction motor can be explained on the basis of double-field revolving theory.

Double-Field Revolving Theory

The double-field revolving theory is proposed to explain this dilemma of no torque at start and yet torque once rotated. This theory is based on the fact that an alternating sinusoidal flux ($\phi = \phi_m \cos \omega t$) can be represented by two revolving fluxes, each equal to one-half of the maximum value of alternating flux (i.e., $\phi_m/2$) and each rotating at synchronous speed ($N_s = 120 f/P$, $\omega = 2\pi f$) in opposite directions.

The above statement will now be proved. The instantaneous value of flux due to the stator current of a single-phase induction motor is given by;

$$\phi = \phi_m \cos \omega t$$

Consider two rotating magnetic fluxes ϕ_1 and ϕ_2 each of magnitude $\phi_m/2$ and rotating in opposite directions with angular velocity ω [See Fig. (9.2)].

Let the two fluxes start rotating from OX axis at

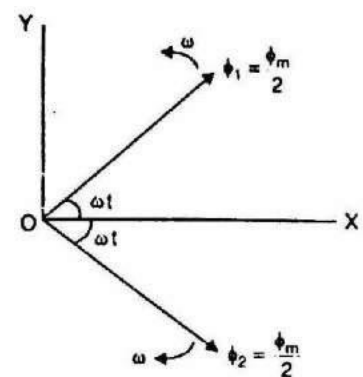

Fig.(9.2)

$t = 0$. After time t seconds, the angle through which the flux vectors have rotated is ωt . Resolving the flux vectors along-X-axis and Y-axis, we have,

$$\text{Total X-component} = \frac{\phi_m}{2} \cos \omega t + \frac{\phi_m}{2} \cos \omega t = \phi_m \cos \omega t$$

$$\text{Total Y-component} = \frac{\phi_m}{2} \sin \omega t - \frac{\phi_m}{2} \sin \omega t = 0$$

$$\text{Resultant flux, } \phi = \sqrt{(\phi_m \cos \omega t)^2 + 0^2} = \phi_m \cos \omega t$$

Thus the resultant flux vector is $\phi = \phi_m \cos \omega t$ along X-axis. Therefore, an alternating field can be replaced by two rotating fields of half its amplitude rotating in opposite directions at synchronous speed. Note that the resultant vector of two revolving flux vectors is a stationary vector that oscillates in length with time along X-axis. When the rotating flux vectors are in phase [See Fig.

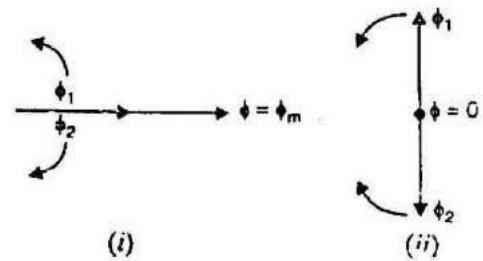

Fig.(9.3)

(9.3 (i))], the resultant vector is $\phi = \phi_m$; when out of phase by 180° [See Fig. (9.3 (ii))], the resultant vector $\phi = 0$.

Let us explain the operation of single-phase induction motor by double-field revolving theory.

(i) Rotor at standstill

Consider the case that the rotor is stationary and the stator winding is connected to a single-phase supply. The alternating flux produced by the stator winding can be presented as the sum of two rotating fluxes ϕ_1 and ϕ_2 , each equal to one half of the maximum value of alternating flux and each rotating at synchronous speed ($N_s = 120 f/P$) in opposite directions as shown in Fig. (9.4 (i)). Let the flux ϕ_1 rotate in anti clockwise direction and flux ϕ_2 in clockwise direction. The flux ϕ_1 will result in the production of torque T_1 in the anti clockwise direction and flux ϕ_2 will result in the production of torque T_2 In the clockwise direction. At standstill, these two torques are equal and opposite and the net torque developed is zero. Therefore, single-phase induction motor is not self-starting. This fact is illustrated in Fig. (9.4 (ii)).

Note that each rotating field tends to drive the rotor in the direction in which the field rotates. Thus the point of zero slip for one field corresponds to 200% slip for the other as explained later. The value of 100% slip (standstill condition) is the same for both the fields.

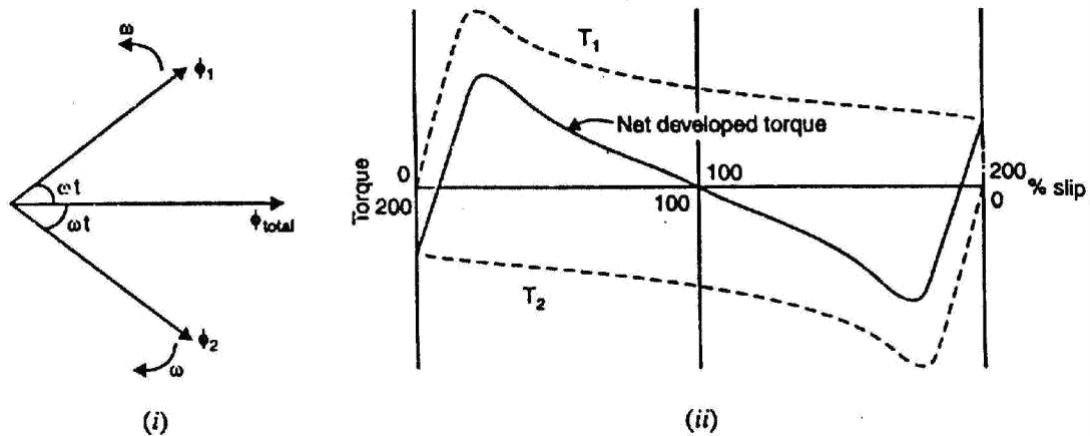

Fig.(9.4)

(ii) Rotor running

Now assume that the rotor is started by spinning the rotor or by using auxiliary circuit, in say clockwise direction. The flux rotating in the clockwise direction is the forward rotating flux (ϕ_f) and that in the other direction is the backward rotating flux (ϕ_b). The slip w.r.t. the forward flux will be

$$s_f = \frac{N_s - N}{N_s}$$

where N_s = synchronous speed

N = speed of rotor in the direction of forward flux

The rotor rotates opposite to the rotation of the backward flux. Therefore, the slip w.r.t. the backward flux will be

$$s_b = \frac{N + N_s}{N_s} = \frac{N}{N_s} + \frac{N_s}{N_s} = s + 1$$

$$s_b = 2 + s$$

Thus for forward rotating flux, slip is s (less than unity) and for backward rotating flux, the slip is $2 + s$ (greater than unity). Since for usual rotor resistance/ reactance ratios, the torques at slips of less than unity are greater than those at slips of more than unity, the resultant torque will be in the direction of the rotation of the forward flux. Thus if the motor is once started, it will develop net torque in the direction in which it has been started and will function as a motor.

Fig. (9.5) shows the rotor circuits for the forward and backward rotating fluxes. Note that $r_2 = R_2/2$, where R_2 is the standstill rotor resistance i.e., r_2 is equal to half the standstill rotor resistance. Similarly, $x_2 = X_2/2$ where X_2 is the standstill rotor reactance. At standstill, $s = 1$ so that impedances of the two circuits are equal. Therefore, rotor currents are equal i.e., $I_{2f} = I_{2b}$. However, when the rotor rotates, the impedances of the two rotor circuits are unequal and the rotor current I_{2b} is higher (and also at a lower power factor) than the rotor current I_{2f} . Their m.m.f.s, which oppose the stator m.m.f.s, will result in a reduction of the backward rotating flux. Consequently, as speed increases, the forward flux increases, increasing the driving torque while the backward flux decreases, reducing the opposing torque. The motor quickly accelerates to the final speed.

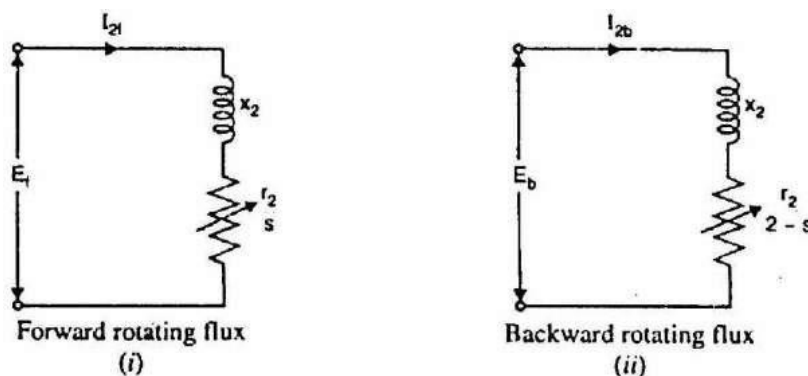

Fig.(9.5)

Making Single-Phase Induction Motor Self-Starting

The single-phase induction motor is not self-starting and it is undesirable to resort to mechanical spinning of the shaft or pulling a belt to start it. To make a single-phase induction motor self-starting, we should somehow produce a revolving stator magnetic field. This may be achieved by converting a single-phase supply into two-phase supply through the use of an additional winding. When the motor attains sufficient speed, the starting means (i.e., additional winding) may be removed depending upon the type of the motor. As a matter of fact, single-phase induction motors are classified and named according to the method employed to make them self-starting.

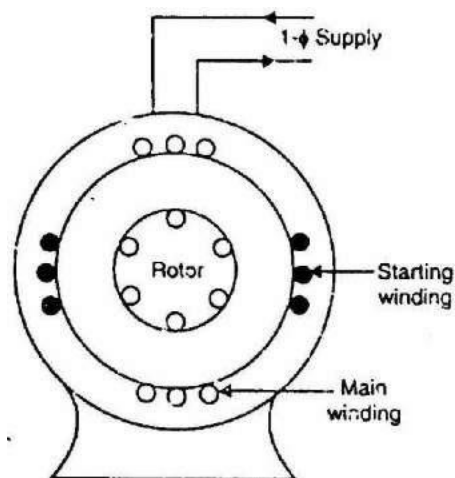

Fig.(9.6)

Split-phase motors-started by two phase motor action through the use of an auxiliary or starting winding.

Capacitor motors-started by two-phase motor action through the use of an auxiliary winding and a capacitor.

Shaded-pole motors-started by the motion of the magnetic field produced by means of a shading coil around a portion of the pole structure.

Split-Phase Induction Motor

The stator of a split-phase induction motor is provided with an auxiliary or starting winding S in addition to the main or running winding M. The starting winding is located 90° electrical from the main winding [See Fig. (9.13 (i))] and operates only during the brief period when the motor starts up. The two windings are so designed that the starting winding S has a high resistance and relatively small reactance while the main winding M has relatively low resistance and large reactance as shown in the schematic connections in Fig. (9.13 (ii)). Consequently, the currents flowing in the two windings have reasonable phase difference α (25° to 30°) as shown in the phasor diagram in Fig. (9.13 (iii)).

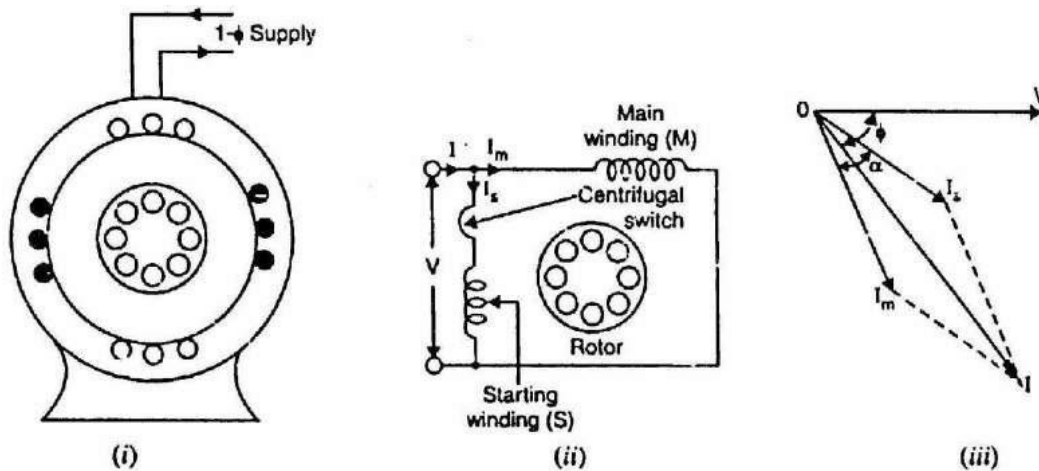

Fig.(9.13)

Operation

When the the main current I_s .

two winding (M) are energized from a single-phase supply, winding carries current I_m while the starting winding carries

Since main winding is made highly inductive while the starting winding highly resistive, the currents I_m and I_s have a reasonable phase angle α (25° to 30°) between them as shown in Fig. (9.13 (iii)). Consequently, a weak revolving field approximating to that of a 2-phase machine is produced which starts the motor. The starting torque is given by;

$$T_s \propto k I_m I_s \sin \alpha$$

where k is a constant whose magnitude depends upon the design of the motor.

When the motor reaches about 75% of synchronous speed, the centrifugal switch opens the circuit of the starting winding. The motor then operates as a single-phase induction motor and continues to accelerate till it reaches the

normal speed. The normal speed of the motor is below the synchronous speed and depends upon the load on the motor.

Characteristics

The starting torque is 1.5 to 2 times the full-load torque and (the starting current is 6 to 8 times the full-load current).

Due to their low cost, split-phase induction motors are most popular single-phase motors in the market.

Since the starting winding is made of fine wire, the current density is high and the winding heats up quickly. If the starting period exceeds 5 seconds, the winding may burn out unless the motor is protected by built-in thermal relay. This motor is, therefore, suitable where starting periods are not frequent.

An important characteristic of these motors is that they are essentially constant-speed motors. The speed variation is 2-5% from no-load to full-load.

These motors are suitable where a moderate starting torque is required and where starting periods are infrequent e.g., to drive:

(a) fans (b) washing machines (c) oil burners (d) small machine tools etc.

The power rating of such motors generally lies between 60 W and 250 W.

Capacitor-Start Motor

The capacitor-start motor is identical to a split-phase motor except that the starting winding has as many turns as the main winding. Moreover, a capacitor C is connected in series with the starting winding as shown in Fig. (9.14 (i)). The value of capacitor is so chosen that I_s leads I_m by about 80° (i.e. $\phi \simeq 80^\circ$) which is considerably greater than 25° found in split-phase motor [See Fig. (9.14 (ii))]. Consequently, starting torque ($T_s = k I_m I_s \sin \phi$) is much more than that of a split-phase motor. Again, the starting winding is opened by the centrifugal switch when the motor attains about 75% of synchronous speed. The motor then operates as a single-phase induction motor and continues to accelerate till it reaches the normal speed.

Characteristics

Although starting characteristics of a capacitor-start motor are better than those of a split-phase motor, both machines possess the same running characteristics because the main windings are identical.

The phase angle between the two currents is about 80° compared to about 25° in a split-phase motor. Consequently, for the same starting torque, the current in the starting winding is only about half that in a split-phase motor. Therefore, the starting winding of a capacitor start motor heats up less

quickly and is well suited to applications involving either frequent or prolonged starting periods.

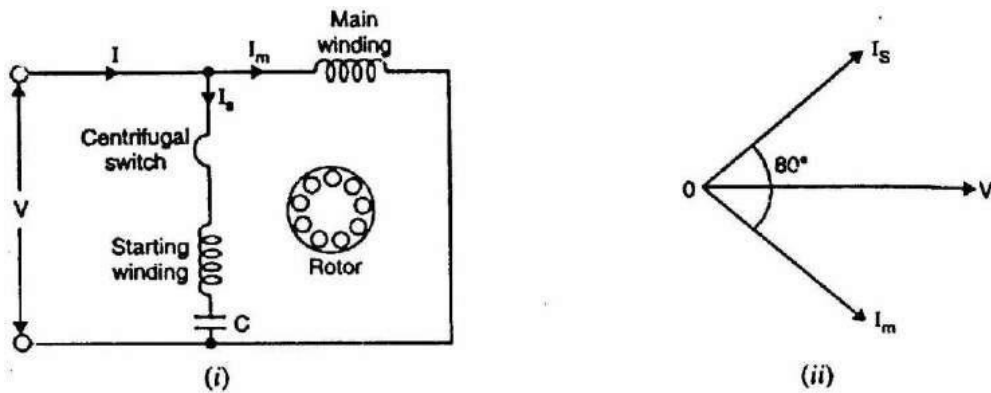

Fig.(9.14)

Capacitor-start motors are used where high starting torque is required and where the starting period may be long e.g., to drive:

- (a) compressors (b) large fans (c) pumps (d) high inertia loads

The power rating of such motors lies between 120 W and 7.5 kW.

Capacitor-Start Capacitor-Run Motor

This motor is identical to a capacitor-start motor except that starting winding is not opened after starting so that both the windings remain connected to the supply when running as well as at starting. Two designs are generally used.

In one design, a single capacitor C is used for both starting and running as shown in Fig.(9.15 (i)). This design eliminates the need of a centrifugal switch and at the same time improves the power factor and efficiency of the motor.

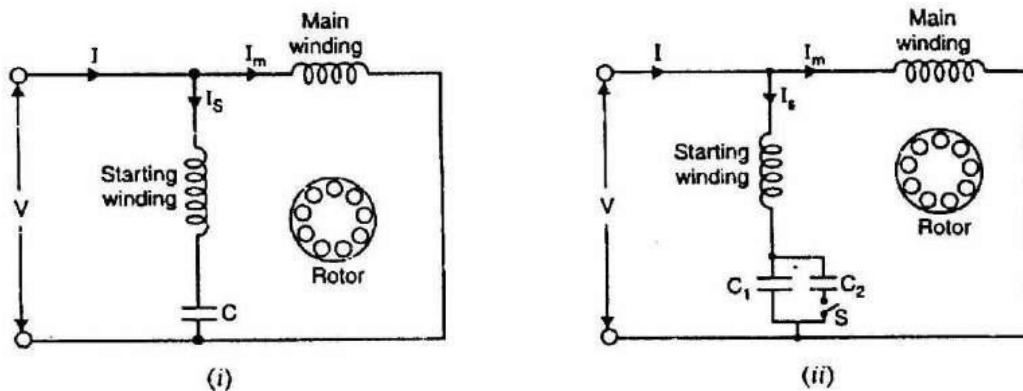

Fig.(9.15)

In the other design, two capacitors C_1 and C_2 are used in the starting winding as shown in Fig. (9.15 (ii)). The smaller capacitor C_1 required for optimum running conditions is permanently connected in series with the

starting winding. The much larger capacitor C_2 is connected in parallel with C_1 for optimum starting and remains in the circuit during starting. The starting capacitor C_1 is disconnected when the motor approaches about 75% of synchronous speed. The motor then runs as a single-phase induction motor.

Characteristics

The starting winding and the capacitor can be designed for perfect 2-phase operation at any load. The motor then produces a constant torque and not a pulsating torque as in other single-phase motors.

Because of constant torque, the motor is vibration free and can be used in:

(b) hospitals (c) studios and (d) other places where silence is important.

Shaded-Pole Motor

The shaded-pole motor is very popular for ratings below 0.05 H.P. (≈ 40 W) because of its extremely simple construction. It has salient poles on the stator excited by single-phase supply and a squirrel-cage rotor as shown in Fig. (9.16). A portion of each pole is surrounded by a short-circuited turn of copper strip called shading coil.

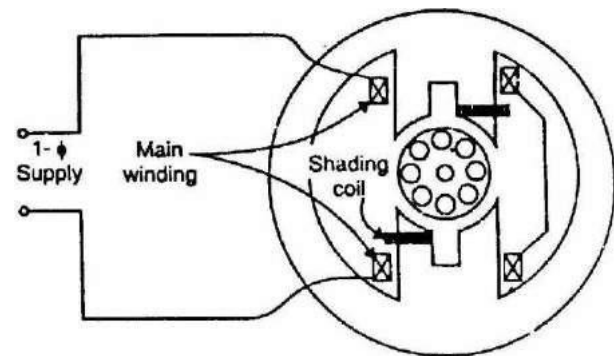

Fig.(9.16)

Operation

The operation of the motor can be understood by referring to Fig. (9.17) which shows one pole of the motor with a shading coil.

During the portion OA of the alternating-current cycle [See Fig. (9.17)], the flux begins to increase and an e.m.f. is induced in the shading coil. The resulting current in the shading coil will be in such a direction (Lenz's law) so as to oppose the change in flux. Thus the flux in the shaded portion of the pole is weakened while that in the unshaded portion is strengthened as shown in Fig. (9.17 (ii)).

During the portion AB of the alternating-current cycle, the flux has reached almost maximum value and is not changing. Consequently, the flux distribution across the pole is uniform [See Fig. (9.17 (iii))] since no current is flowing in the shading coil. As the flux decreases (portion BC of the alternating current cycle), current is induced in the shading coil so as to oppose the decrease in current. Thus the flux in the shaded portion of the

pole is strengthened while that in the unshaded portion is weakened as shown in Fig. (9.17 (iv)).

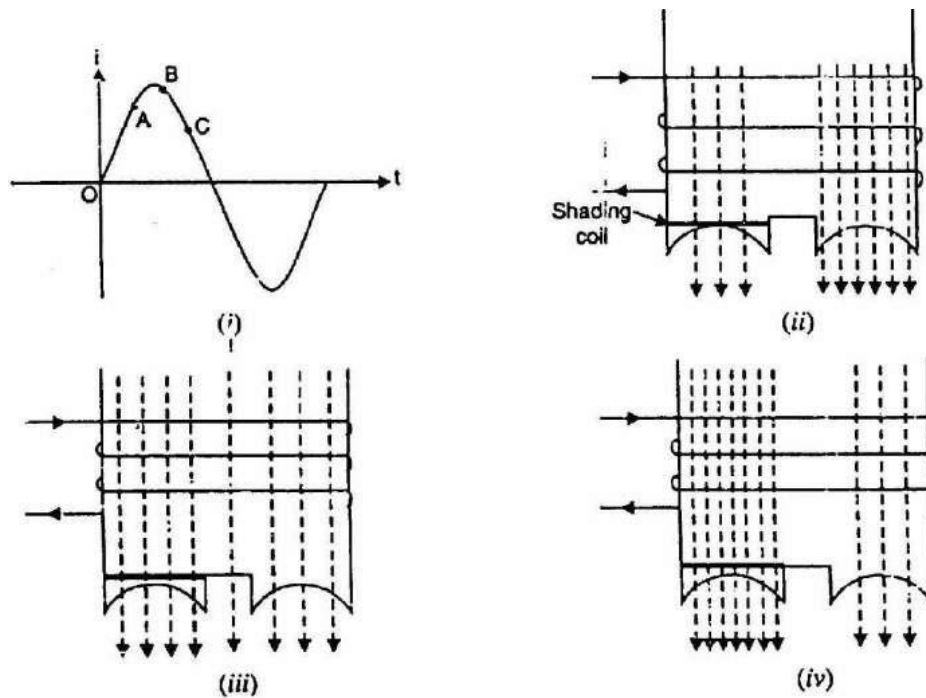

Fig.(9.17)

The effect of the shading coil is to cause the field flux to shift across the pole face from the unshaded to the shaded portion. This shifting flux is like a rotating weak field moving in the direction from unshaded portion to the shaded portion of the pole.

The rotor is of the squirrel-cage type and is under the influence of this moving field. Consequently, a small starting torque is developed. As soon as this torque starts to revolve the rotor, additional torque is produced by single-phase induction-motor action. The motor accelerates to a speed slightly below the synchronous speed and runs as a single-phase induction motor.

Characteristics

The salient features of this motor are extremely simple construction and absence of centrifugal switch.

Since starting torque, efficiency and power factor are very low, these motors are only suitable for low power applications e.g., to drive:

- small fans (b) toys (c) hair driers (d) desk fans etc.

The power rating of such motors is upto about 30 W.

A.C. Series Motor or Universal Motor

A d.c. series motor will rotate in the same direction regardless of the polarity of the supply. One can expect that a d.c. series motor would also operate on a single-phase supply. It is then called an a.c. series motor. However, some changes must be made in a d.c. motor that is to operate satisfactorily on a.c. supply. The changes effected are:

The entire magnetic circuit is laminated in order to reduce the eddy current loss. Hence an a.c. series motor requires a more expensive construction than a d.c. series motor.

The series field winding uses as few turns as possible to reduce the reactance of the field winding to a minimum. This reduces the voltage drop across the field winding.

A high field flux is obtained by using a low-reluctance magnetic circuit.

There is considerable sparking between the brushes and the commutator when the motor is used on a.c. supply. It is because the alternating flux establishes high currents in the coils short-circuited by the brushes. When the short-circuited coils break contact from the commutator, excessive sparking is produced. This can be eliminated by using high-resistance leads to connect the coils to the commutator segments.

Construction

The construction of an a.c. series motor is very similar to a d.c. series motor except that above modifications are incorporated [See Fig. (9.20)]. Such a motor can be operated either on a.c. or d.c. supply and the resulting torque-speed curve is about the same in each case. For this reason, it is sometimes called a universal motor.

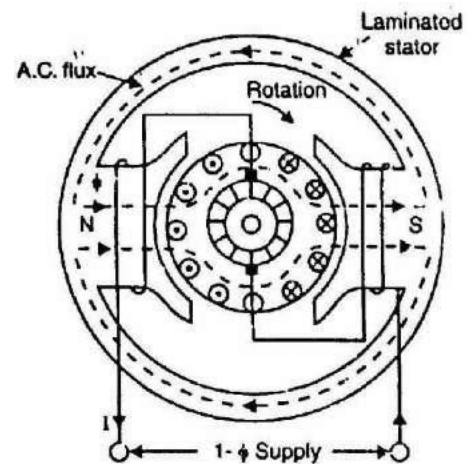

Fig.(9.20)

Operation

When the motor is connected to an a.c. supply, the same alternating current flows through the field and armature windings.

The field winding produces an alternating flux ϕ that reacts with the current flowing in

the armature to produce a torque. Since both armature current and flux reverse simultaneously, the torque always acts in the same direction. It may be noted that no rotating flux is produced in this type of machines; the principle of operation is the same as that of a d.c. series motor.

Characteristics

The operating characteristics of an a.c. series motor are similar to those of a d.c. series motor.

The speed increases to a high value with a decrease in load. In very small series motors, the losses are usually large enough at no load that limit the speed to a definite value (1500 - 15,000 r.p.m.).

The motor torque is high for large armature currents, thus giving a high starting torque.

At full-load, the power factor is about 90%. However, at starting or when carrying an overload, the power factor is lower.

Applications

The fractional horsepower a.c. series motors have high-speed (and corresponding small size) and large starting torque. They can, therefore, be used to drive:

- (a) high-speed vacuum cleaners
- (b) sewing machines
- (c) electric shavers
- (d) drills
- (e) machine tools etc.

A.C. system has a number of advantages over d.c. system. These days 3-phase a.c. system is being exclusively used for generation, transmission and distribution of power. The machine which produces 3-phase power from mechanical power is called an alternator or synchronous generator. Alternators are the primary source of all the electrical energy we consume. These machines are the largest energy converters found in the world. They convert mechanical energy into a.c. energy

Alternator

An alternator operates on the same fundamental principle of electromagnetic induction as a d.c. generator i.e., when the flux linking a conductor changes, an e.m.f. is induced in the conductor. Like a d.c. generator, an alternator also has an armature winding and a field winding. But there is one important difference between the two. In a d.c. generator, the armature winding is placed on the rotor in order to provide a way of converting alternating voltage generated in the winding to a direct voltage at the terminals through the use of a rotating commutator. The field poles are placed on the stationary part of the machine. Since no commutator is required in an alternator, it is usually more convenient and advantageous to place the field winding on the rotating part (i.e., rotor) and armature winding on the stationary part (i.e., stator) as shown in Fig. (10.1).

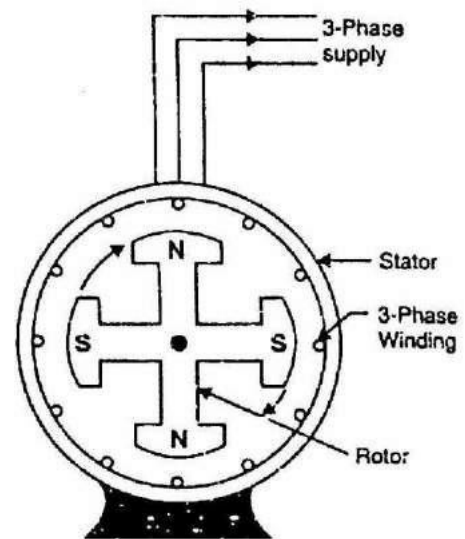

Fig.(10.1)

Advantages of stationary armature

The field winding of an alternator is placed on the rotor and is connected to d.c. supply through two slip rings. The 3-phase armature winding is placed on the stator. This arrangement has the following advantages:

It is easier to insulate stationary winding for high voltages for which the alternators are usually designed. It is because they are not subjected to centrifugal forces and also extra space is available due to the stationary arrangement of the armature.

The stationary 3-phase armature can be directly connected to load without going through large, unreliable slip rings and brushes.

Only two slip rings are required for d.c. supply to the field winding on the rotor. Since the exciting current is small, the slip rings and brush gear required are of light construction.

Due to simple and robust construction of the rotor, higher speed of rotating d.c. field is possible. This increases the output obtainable from a machine of given dimensions.

Note: All alternators above 5 kVA employ a stationary armature (or stator) and a revolving d.c. field.

Construction of Alternator

An alternator has 3-phase winding on the stator and a d.c. field winding on the rotor.

Stator

It is the stationary part of the machine and is built up of sheet-steel laminations having slots on its inner periphery. A 3-phase winding is placed in these slots and serves as the armature winding of the alternator. The armature winding is always connected in star and the neutral is connected to ground.

Rotor

The rotor carries a field winding which is supplied with direct current through two slip rings by a separate d.c. source. This d.c. source (called exciter) is generally a small d.c. shunt or compound generator mounted on the shaft of the alternator. Rotor construction is of two types, namely;

Salient (or projecting) pole type

Non-salient (or cylindrical) pole type

Salient pole type

In this type, salient or projecting poles are mounted on a large circular steel frame which is fixed to the shaft of the alternator as shown in Fig. (10.2). The individual field pole windings are connected in series in such a way that when the field winding is energized by the d.c. exciter, adjacent poles have opposite polarities.

Low and medium-speed alternators (120-400 r.p.m.) such as those driven by diesel engines or water turbines have salient pole type rotors due to the following reasons:

The salient field poles would cause an excessive windage loss if driven at high speed and would tend to produce noise.

Salient-pole construction cannot be made strong enough to withstand the mechanical stresses to which they may be subjected at higher speeds.

Since a frequency of 50 Hz is required, we must use a large number of poles on the rotor of slow-speed alternators. Low-speed rotors always possess a large diameter to provide the necessary space for the poles. Consequently, salient-pole type rotors have large diameters and short axial lengths.

Non-salient pole type

In this type, the rotor is made of smooth solid forged-steel radial cylinder having a number of slots along the outer periphery. The field windings are embedded in these slots and are connected in series to the slip rings through which they are energized by the d.c. exciter. The regions forming the poles are usually left unslotted as shown in Fig. (10.3). It is clear that the poles formed are non-salient i.e., they do not project out from the rotor surface.

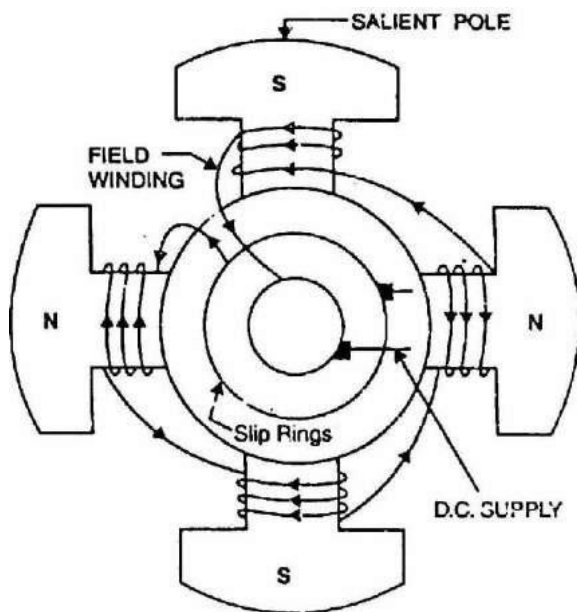

Fig.(10.2)

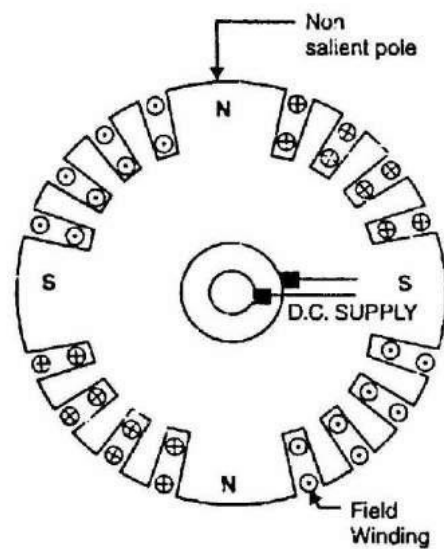

Fig.(10.3)

High-speed alternators (1500 or 3000 r.p.m.) are driven by steam turbines and use non-salient type rotors due to the following reasons:

This type of construction has mechanical robustness and gives noiseless operation at high speeds.

The flux distribution around the periphery is nearly a sine wave and hence a better e.m.f. waveform is obtained than in the case of salient-pole type.

Since steam turbines run at high speed and a frequency of 50 Hz is required, we need a small number of poles on the rotor of high-speed alternators (also called turboalternators). We can use not less than 2 poles and this fixes the highest possible speed. For a frequency of 50 Hz, it is 3000 r.p.m. The next lower speed is 1500 r.p.m. for a 4-pole machine. Consequently, turboalternators possess 2 or 4 poles and have small diameters and very long axial lengths.