



**GOVERNMENT POLYTECHNIC, BHUBANESWAR**

Government of Odisha

ସରକାରୀ ବହୁବୃତ୍ତି ଅନୁଷ୍ଠାନ, ଭୁବନେଶ୍ୱର

**DIGITAL CONTENT  
OF**

**Electrical  
Installation  
And Estimating**

PREPARED BY- ROJALIN CHOUDHURY

# ELECTRICAL INSTALLATION AND ESTIMATING

## Wiring Systems and Types of House Wiring

### What is Electrical Wiring?

- A network of cables connecting various electrical accessories for distribution of electrical energy from the supplier meter board to the various electrical energy consuming devices such as lamps, fans, radio, TV and other domestic appliances through controlling and safety devices is known as wiring system.
- The supplier service cable feeding an installation terminates at services fuses (some times called service cutouts).
- Service cutouts including service meter (i.e. energy meter) remains the property of the supplier.
- The point at which the consumer wiring is connected in to the cutout is known as point of commencement of supply or consumers terminals.
- From consumer terminals onwards the supply cables are under the control of consumers and so laid as per his choice

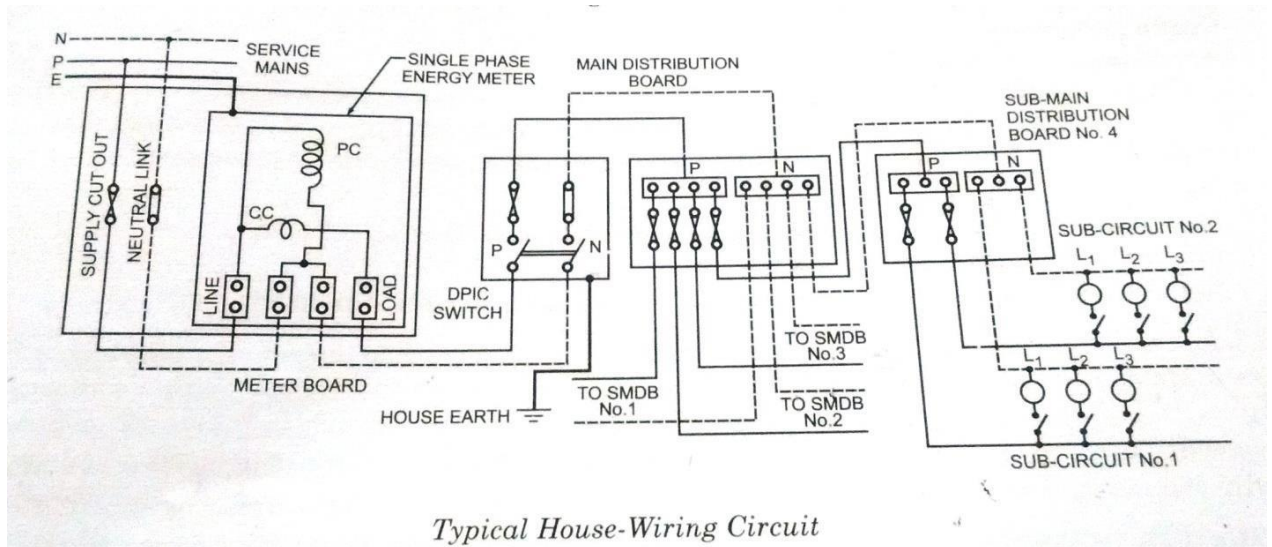

### Electrical Energy Distribution Systems

#### (a) Distribution Board System

- It is the most commonly adopted system for distribution of electrical energy in buildings.

- The fuses of all circuits are grouped on a distribution board and is also known as fuse board [now – a – days the DP (double-pole) main switch and fuses are grouped on a single board only].
- The two cu strips known as busbar fixed in distribution board of metal case are connected to supply mains through a linked switch.
- The distribution board shown in above fig has 4 sub-circuits or ways, each circuit is provided with a fuse(phase pole of each circuit)
- In large building sub distribution board are used to save cable or to prevent too great voltage drop.

**(b) Tree System**

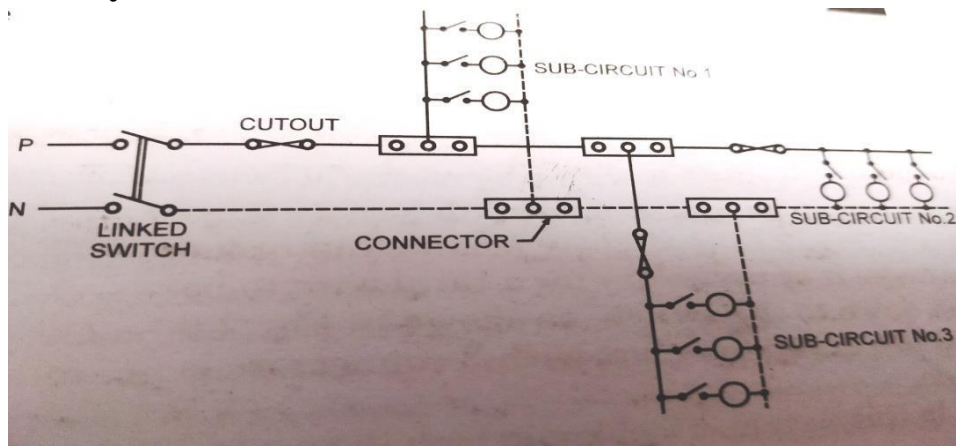

- In tree system the sub circuits are taken from the main circuit or main line as shown in fig .
- The wiring system resembles like a tree, hence it is known as tree system.
- Now – a – days this system is obsolete

Drawbacks :

1. Voltage across all the lamp does not remain same
2. A no. of joints are involved in every circuit.
3. Fuses are scattered.
4. difficulty to find the fault.

**Methods of wiring**

a) Joint Box or Tee System:

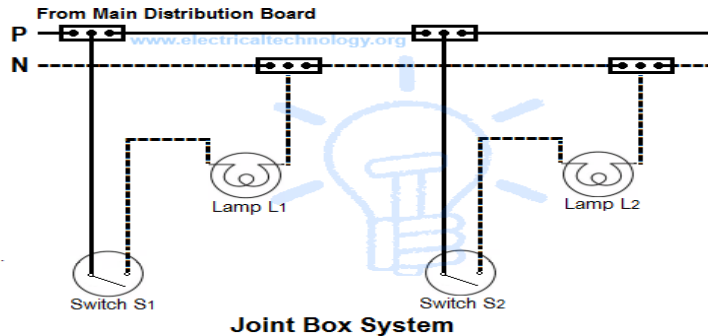

- In this method of wiring, connections to appliances are made through joints.
- These joints are made in joint boxes by means of suitable connectors or joints cutouts.
- This method of wiring doesn't consume too much [cables size](#). it is therefore cheaper. but the money you saved from buying cables will be used in buying joint boxes, thus equation is balanced
- This method is suitable for temporary installations

### *Loop-in or Looping System*

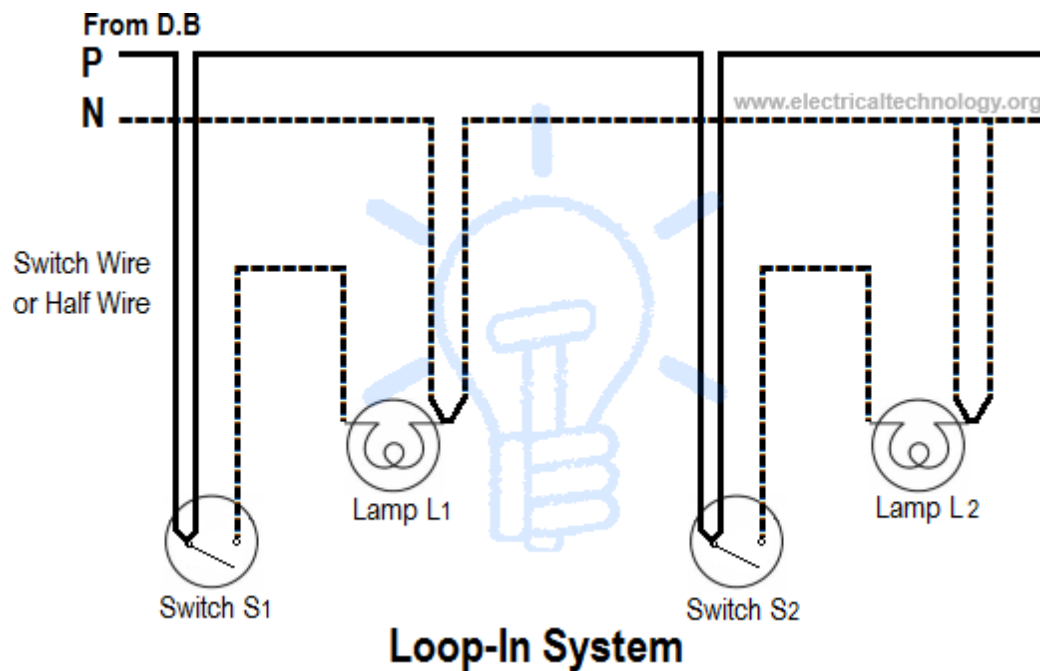

- This method of wiring is universally used in wiring. Lamps and other appliances are connected in parallel so that each of the appliances can be controlled individually.
- When a connection is required at a light or [switch](#), the feed conductor is looped in by bringing it directly to the terminal and then carrying it forward again to the next point to be fed.
- The switch and light feeds are carried round the circuit in a series of loops from one point to another until the last on the circuit is reached.
- The phase or line conductors are looped either in switchboard or box and neutrals are looped either in switchboard or from light or fan. Line or phase should never be looped from light or fan

### **Advantages**

- It doesn't require joint boxes and so money is saved
- In loop – in systems, no joint is concealed beneath floors or in roof spaces.
- Fault location is made easy as the points are made only at outlets so that they are accessible.

### **Disadvantages**

- Length of wire or cables required is more and voltage drop and copper losses are therefore more
- Looping – in switches and lamp holders is usually difficult.

### **Systems of wiring**

Electrical wiring system is classified into five categories:

- Cleat wiring
- Wooden casing and capping wiring
- CTS or TRS or PVC sheath wiring
- Lead sheathed or metal sheathed wiring
- Conduit wiring
  1. Surface or open Conduit type
  2. Recessed or concealed or underground type Conduit

## A. Cleat Wiring

### *Material Used in Cleat Wiring*

- VIR or PVC insulated wires
- Weather proof cables
- Porcelain cleats or plastic cleats (two or three grooves)
- Screws
- In this system of wiring cables are supported and gripped between porcelain cleats **6mm.** above the wall or roof.
- The porcelain cleats are made in two halves. The main part is base, which is grooved to accommodate the cables, the other part is the cap which is put over the base
- The lower cleat (base) and upper cover (cap), after placing cables between them are then screwed on wooden gutties.
- The screw used in this case are of size 38mm length.
- The gutties are previously fixed into the walls or roof at an interval of **30 to 60 cm.** if the distance between the cleats is increased, there is every risk of cables touching the walls.
- For low voltage (up to 250-V) installation, cleats shall be such dimensions that cables shall not be less than **2.5 cm.** apart for branch circuits and, should not less than **4 cm.** apart for sub mains.
- Only one cable should be placed in each groove

### Advantages

1. It is the cheapest system.
2. Installation and dismantling is easy.
3. Less skilled persons are required.
4. Inspection is easy.
5. Alterations and additions are easy.
6. As the cables and wires of cleat wiring system is in open air, Therefore fault in cables can be seen and repair easily

### Disadvantages

1. It is purely temporary wiring system.
2. Appearance is not good.
3. Cables are exposed to atmosphere and there is a possibility of mechanical injury.
4. This system should not be used in damp places otherwise insulation gets damaged.
5. it is not lasting wire system because of the weather effect and wear & tear
6. it can be only used on 250/440 Volts on low temperature.

7. There is always a risk of fire and electric shock.
8. it can't be used in important and sensitive location and places.
9. It is not reliable and sustainable wiring system.

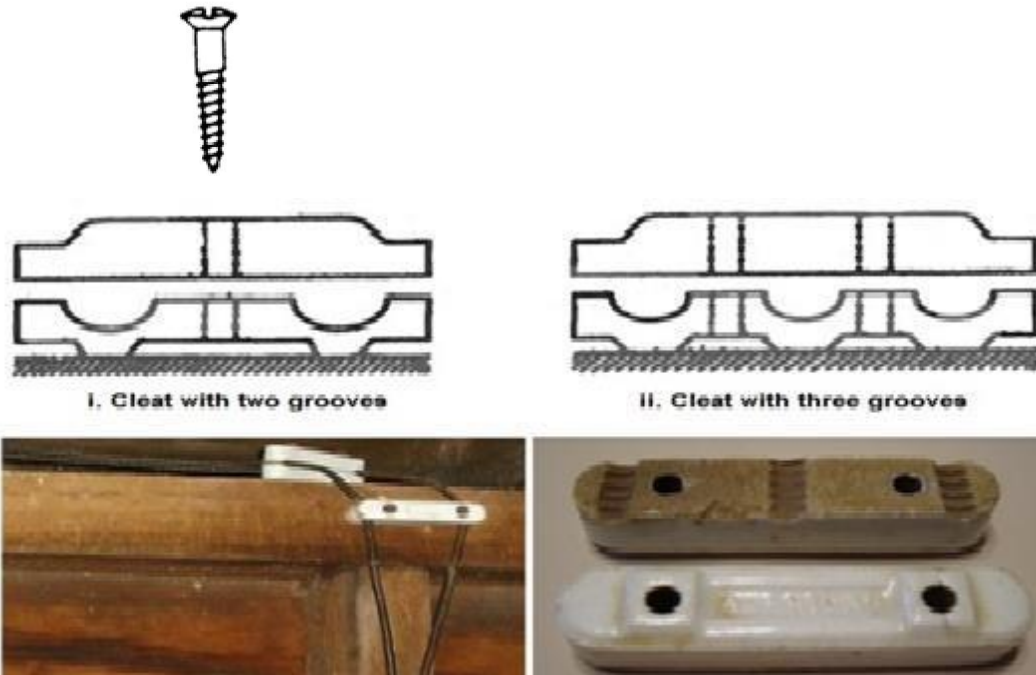

Application:

- Suitable for temporary installation in dry places i.e. under construction building or army camping

## ***B. Casing and Capping wiring***

### ***Material Used in Casing Wiring***

- VIR or PVC insulated wires
  - Casing Enclosure (made of wood or plastic)
  - Capping (made of wood or plastic)
  - Casing and capping joints.
- It consists of rectangular blocks made from seasoned and knots free wood or PVC.
  - The casing has usually two (or three) 'U' shaped grooves, (two in number) into which the VIR or PVC cables are laid in such a way that the opposite polarity cables are laid in different grooves.
  - The casing is covered by means of a rectangular strip of the same width as that of casing known as capping and is screwed to it.
  - This system of wiring is suitable for low voltage installations.



- The casing must be kept at least **3.2 mm**. apart from the walls or ceiling by means of porcelain pieces of thickness not less than **6.5mm** to keep the casing dry at the back
- The wooden gutties on which the casing is screwed by **32mm×8mm** wooden screws must be fitted into wall at an interval not exceeding **90cm** for size of casing capping upto **64mm** and not exceeding **60cm** for size more than **64mm**
- The capping is screwd to the casing by **12.7mm** length fixed at every **15cm** for wooden casing capping and capping itself is designed for tight fit over the casing in case of PVC casing capping
- Joint is required since casing capping length available from **2.5m to 3m**
- Casing capping should be painted or varnished after erection

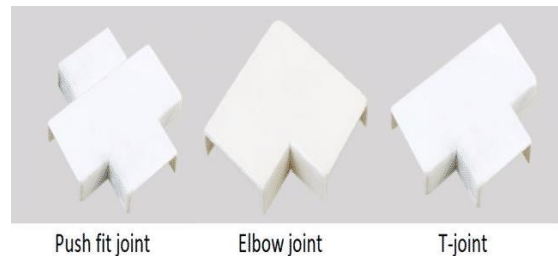

### Advantages

1. It provides good mechanical strength.
2. Easy to inspect by opening the capping.
3. It is cheap wiring system as compared to sheathed and conduit wiring systems.
4. It is strong and long-lasting wiring system.
5. If Phase and Neutral wire is installed in separate slots, then repairing is easy.
6. Stay for long time in the field due to strong insulation of capping and casing..
7. It stays safe from oil, Steam, smoke and rain.
8. No risk of electric shock due to covered wires and cables in casing & capping

### Disadvantages

1. Difficulty in finding any fault caused in the wire.



2. There is a high risk of fire in casing & capping wiring system.
3. Not suitable in the acidic, alkalies and humidity conditions
4. Costly repairing and need more material.
5. Material can't be found easily in the contemporary
6. White ants may damage the casing & capping of wood.
7. This system can not be used in damp places.

Application:

Used in low voltage residential and office building.

Wiring Systems 27

**TABLE 2.1** Size of wood casing and capping and the number of wires that may be accommodated in one groove of the casing

Width of casing or capping in mm	No. of grooves	Width of grooves in mm	Thickness of casing in mm	Thickness at the back under the groove of casing in mm	Thickness of outer wall in mm	Thickness of capping in mm
38	2	6				
44	2	6	16	6	7	6
51	2	9	16	6	10	10
64	2	13	19	6	10	10
76	2	16	19	10	10	10
89	2	16	25	10	10	10
102	2	19	32	10	11	13
			32	13	13	13

Size of cable in mm <sup>2</sup>	Number of cables that can be drawn in one groove of casing-capping of size COPPER CONDUCTORS ONLY						
	38 mm	44 mm	51 mm	64 mm	76 mm	89 mm	102 mm
1.0	2	2	3	3	9	12	12
1.25	1	1	2	2	8	12	12
1.5	1	1	2	2	8	12	12
2.0	1	1	2	2	5	10	10
2.5	1	1	2	2	5	10	10
3.0	-	-	2	2	5	8	9
4.0	-	-	2	2	5	8	9
4.5	-	-	1	1	4	6	6
6.0	-	-	1	1	4	6	6
10.0	-	-	1	1	2	3	4
14.0	-	-	-	-	1	2	2
16.0	-	-	-	-	1	2	2
25.0	-	-	-	-	1	1	1
35.0	-	-	-	-	1	1	1
40.0	-	-	-	-	1	1	1
50.0	-	-	-	-	1	1	1

### **C. Batten Wiring (CTS or TRS)**

#### **Material Used in Batten Wiring**

- CTS or TRS cable
- Straight teak wooden batten (at 10 mm thick)
- Tinned brass link clip ( buckle clip)
- Brass pins
- The cables are run or carried on well seasoned, perfectly straight and well varnished (on all four sides) teak wood batten of thickness 10 mm. at least.
- The width of the batten depends upon the number and size of cables to be carried by it. The batten is available in widths of 6, 13, 19, 25, 31, 38, 44, 50, 56, 63, 69 and 75 mm.
- The wooden battens are fixed to the walls or ceilings by means of PVC gutties or wooden plugs with flat head wooden screws, the wooden screws should be fixed on the batten at an interval not exceeding **75cm**.
- The cables are held on the wooden batten by means of tinned brass link clips already fixed on the batten with (brass) pins and spaced at an interval of 10 cm. in horizontal run and 15cm in vertical run.
- the wiring after completion should be neatly painted with two coats of oil – less, non – cracking paint

#### **Advantages**

1. Wiring installation is simple and easy
2. cheap as compared to other electrical wiring systems
3. Repairing is easy
4. strong and long-lasting
5. Appearance is better.
6. Customization is easy
7. Less chance of leakage current

#### **Disadvantages**

1. Not suitable for outdoor wiring
2. Humidity, smoke, steam etc directly affect on wires.
3. Heavy wires are not recommended for this wiring scheme.
4. Only suitable for below 250 V.
5. High risk of fire.
6. Good work man ship is required to make a sound job
7. Cannot be used in damp places
8. Appearance is not so beautiful as compared to conduit wiring

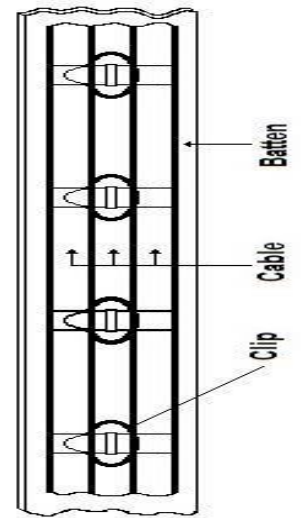

**Application:**

- Used in domestic, commercial or industrial wiring except workshops
- Used for low voltage installation

**TABLE 2.2**

Number of cables of size 3/0.736 mm copper conductor or 1/1.40 mm aluminium conductor single core that can be laid	Size of batten required	Number and size of link clips required
2	13 × 13 mm	1 × 38 mm
3	19 × 13 mm	1 × 50 mm
4	25 × 13 mm	2 × 38 mm
5	31 × 13 mm	1 × 38 mm and 1 × 50 mm
6	38 × 13 mm	3 × 38 mm
7	44 × 13 mm	2 × 38 mm and 1 × 50 mm
8	50 × 13 mm	1 × 38 mm and 2 × 50 mm
9	56 × 13 mm	3 × 50 mm
10	63 × 13 mm	2 × 38 mm and 2 × 50 mm
11	69 × 13 mm	1 × 38 mm and 3 × 50 mm
12	75 × 13 mm	4 × 50 mm



#### *D. Lead Sheathed Wiring*

- The type of wiring employs conductors that are insulated with VIR and covered with an outer sheath of lead aluminum alloy containing about 95% of lead.
- The metal sheath given protection to cables from mechanical damage, moisture and atmospheric corrosion.
- The whole lead covering is made electrically continuous and is connected to earth at the point of entry to protect against electrolytic action due to leaking current and to provide safety in case the sheath becomes alive.
- The cables are run on wooden batten and fixed by means of link clips just as in TRS wiring

#### Advantages

1. Provides protection against mechanical injury better than TRS wiring
2. Easy to fix and looks nice
3. Long life if proper earth continuity is maintained
4. Can be used in damp situation and in situation exposed to rain & sun

#### Disadvantages

1. Costlier than TRS wiring
2. Not suitable for chemical corrosion
3. In case of damage of insulation the metal sheath becomes alive & give shock
4. Skilled labour & proper supervision is required

#### Application:

Commonly used for laying submains from pole to electric meter

#### **E. CONDUIT WIRING**

##### *Material Used in Conduit Wiring*

- *Conduit*
- VIR or PVC insulated cables
- GI wire of 18SWG
- Screw
- Coupling
- Elbow
- Rigid off set
- 2-hole strap
- Lock nut

- There are two additional types of conduit wiring according to pipe installation
  - **Surface Conduit Wiring**
  - **Concealed Conduit Wiring**

##### *Surface Conduit Wiring*

If conduits installed on roof or wall, It is known as surface conduit wiring. in this wiring method, they make holes on the surface of wall on equal distances and conduit is installed then with the help of rawal plugs.

### *Concealed Conduit wiring*

If the conduits is hidden inside the wall slots with the help of plastering, it is called concealed conduit wiring. In other words, the electrical wiring system inside wall, roof or floor with the help of plastic or metallic piping is called concealed conduit wiring. obviously, It is the **most popular, beautiful, stronger and common electrical wiring system** nowadays.

- In conduit wiring, steel tubes known as conduits are installed on the surface of walls by means of pipe hooks (surface conduit wiring) or buried in walls under plaster and VIR or PVC cables are afterwards drawn by means of a GI wire of size if about 18SWG.
- In damp situation conduit can be spaced from the wall by wooden blocks
- The conduits should be electrically continuous and connected to earth at some suitable points in case of steel conduit.
- Inspection T,bends or joint boxes should be used at all bends.
- Conduit pipes should be fixed by saddle at an interval of not more than **1m**
- When conduit are buried under plaster it must be screwed to wall behind first.
- GI wire is used to lay down the wires through the conduit pipe

### *Advantages*

1. The safest wiring
2. Appearance is better
3. No risk of fire or mechanical wear and tear.
4. No risk of damage of cable insulation
5. Safe from humidity, smoke, steam etc.
6. No risk of shock
7. Long lasting
8. it is safe from corrosion
9. system is waterproof
10. Repairing and maintenance is easy.

### *Disadvantages*

1. Very expensive
2. Installation is not easy
3. Not easy to customize for future
4. Hard to detect the faults.
5. Risk of Electric shock (In case of metallic pipes without proper earthing system)
6. Experienced & highly skilled labour is required

### *Application:*

1. Places where dust or fluff is present such as in textile mills, sawmills, flour mills etc
2. Damp situation
3. In workshop
4. Residential,commercial and public building

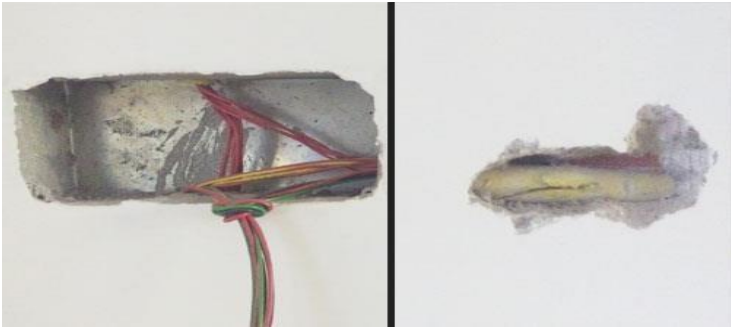

**TABLE 2.3** Maximum capacity of conduits for drawing-in of 1,100 V grade cables

Nominal x-sectional area in mm <sup>2</sup>	Number and diameter of wires in mm	Material of conductor	Number of cables that can be accommodated in conduit of size													
			19 mm		25 mm		31 mm		38 mm		50 mm		63 mm			
			S	B	S	B	S	B	S	B	S	B	S	B		
1.0	1/1.12	Copper	7	5	13	10	20	14	-	-	-	-	-	-	-	-
1.25	3/0.736	Copper	7	5	12	10	20	14	-	-	-	-	-	-	-	-
1.5	1/1.40	Al	7	5	12	10	20	14	-	-	-	-	-	-	-	-
2.0	3/0.925	Copper	5	4	10	8	18	12	-	-	-	-	-	-	-	-
2.5	1/1.80	Al	6	5	10	8	18	12	-	-	-	-	-	-	-	-
3.0	7/0.736	Copper	5	4	8	6	12	10	-	-	-	-	-	-	-	-
4.0	1/2.24	Al	4	3	7	6	12	10	-	-	-	-	-	-	-	-
4.5	7/0.925	Copper	3	2	6	5	10	8	-	-	-	-	-	-	-	-
6.0	1/2.80	Al	3	2	6	5	10	8	-	-	-	-	-	-	-	-
6.75	7/1.12	Copper	2	-	5	4	8	7	-	-	-	-	-	-	-	-
10	1/3.55	Al	2	-	5	4	8	7	-	-	-	-	-	-	-	-
12	7/1.32	Copper	2	-	4	3	6	5	8	6	-	-	-	-	-	-
14	7/1.626	Copper	-	-	3	2	4	4	7	6	-	-	-	-	-	-
16	7/1.70	Al	-	-	2	-	4	3	7	6	-	-	-	-	-	-
18	19/1.12	Copper	-	-	-	-	4	3	6	5	10	7	12	8	-	-
25	7/2.24	Al	-	-	-	-	3	2	5	4	8	6	9	7	-	-
30	19/1.32	Copper	-	-	-	-	3	2	5	4	8	6	9	7	-	-
35	7/2.50	Al	-	-	-	-	2	-	4	3	7	5	8	6	-	-
40	19/1.626	Copper	-	-	-	-	-	-	3	3	6	5	8	6	-	-
50	7/3.00	Al	-	-	-	-	-	-	4	3	6	4	6	5	-	-
50	19/1.80	Copper	-	-	-	-	-	-	2	-	5	4	6	5	-	-

**Note:** The table shows the maximum capacity of conduit for the simultaneous drawing-in of cables. The Table applies to 1,100 V grade cables. The columns headed 'S' apply to runs of conduit which have distance not exceeding 4.25 metres between draw-in-boxes, and which do not deflect from straight by an angle of more than 15°. The columns headed B apply to runs of conduit which deflect from the straight by an angle of more than 15°.

## factors affecting the choice of wiring system

When making choice for any wiring system for a particular installation, your choice should be based on technical and economic factors.

1. **Cost of wiring:** The initial cost of the wiring system to be chosen or selected is one of the paramount factors to be considered. It should be economical and safe.
2. **Durability:** When making choices for wiring system, the wiring type should be durable (long lasting) and should also be of proper specifications and in accordance with assessed life and type of building to be wired. Any wiring should withstand wear and tear that may result due to unfavorable weather. The cables used should be able to carry maximum current without overheating.
3. **Permanency:** The wiring should not deteriorate by the action of weather, fumes, dampness etc. the cables should be resistant to harsh weather and chemical attacks.
4. **Accessibility:** Facilities used in the wiring should be available (within range) and accessible when the need for alteration, extension or renewal arises.
5. **Appearance:** The wiring should provide a good look after its installation. If cleat or casing – capping wiring is used in a modern building, it will spoil the outlook of that building. Conduit wiring is preferred mostly for modern buildings except that it's expensive. PVC wiring system is also good for modern buildings. PVC wiring is very popular.
6. **Mechanical Protection:** The wiring should be protected from mechanical damage during its use.
7. **Safety:** When it comes to wiring, safety is one of the most paramount factors to be considered because electrocution is one thing you won't have the time to give it a second thought. Where there is possibility of fire hazard, conduit wiring should be used.
8. **Maintenance Cost:** Wiring system employed should have low maintenance cost.
9. **Load:** The types of loads consuming the electrical energy in a building will determine the kinds of cables to be used. You cannot use a cable with small diameter for heavy loads. The cables will damage. Voltage to be employed and fire hazard and insurance standards should also be kept in mind in case of large factories.



# Lighting Schemes

## General principles of good lighting

- Not injurious, rather protect our health by minimizing eye strain.
- It must provide plentiful but glare free light for all kinds of tasks.
- Provision of spot lights for tasks like sewing, reading etc.
- No source of light should appear in the visual field of any worker during working operations.
- As far as possible all lights should be provided with shades
- Prevent accidents especially at such hazards as in staircases.
- Ensure absence of harsh shadows.
- It must create sufficient contrast between dark and light areas to prevent dullness and monotonous.
- Maintain aesthetic appearance, contribute beauty and individuality to home

## Realization of these aims involves:

- a) Careful planning of brightness and colour patterns within the working area
- b) Using directional lighting to assist perception of task and to give good modeling
- c) Controlling direct and reflected glare from light source
- d) Minimizing flicker from certain types of lamp
- e) Installing emergency lighting system where necessary

## Types of Lighting Schemes:

Lighting schemes are classified according to the location, requirement and purpose etc. are as under :

1. Direct lighting
2. Indirect lighting
3. Semi direct lighting
4. Semi indirect lighting
5. General lighting

### i. Direct Lighting:

- It is most commonly used type of lighting scheme. In this lighting scheme more than 90 percent of total light flux is made to fall directly on the working plane with the help of deep reflectors.
- Though it is most efficient but causes hard shadows and glare.

- It is mainly used for industrial and general out-door lighting.

## **ii. Semi-Direct Lighting:**

- In this lighting scheme 60 to 90 percent of the total light flux is made to fall downwards directly with the help of semi-direct reflectors, remaining light is used to illuminate the ceiling and walls.
- Such a lighting system is best suited to rooms with high ceilings where a high level of uniformly distributed illumination is desirable.
- Glare in such units is avoided by employing diffusing globes which not only improve the brightness towards the eye but improve the efficiency of the systems with reference to working place.

## **iii. Semi-Indirect Lighting:**

- In this lighting scheme 60 to 90 percent of total light flux is thrown upwards to the ceiling for diffuse reflection and the rest reaches the working plane directly except for some absorption by the bowl.
- This lighting scheme is with soft shadows and glare free.
- It is mainly used for indoor light decoration purposes

## **iv. Indirect Lighting:**

- In this light scheme more than 90 percent of total light flux is thrown upwards to the ceiling for diffuse reflection by using inverted or bowl reflectors.
- In such a system the ceiling acts as the light source, and the glare is reduced to minimum.
- The resulting illumination is softer and more diffused, the shadows are less prominent and the appearance of the room is much improved over that which results from direct lighting.
- It is used for decoration purposes in cinemas theatres and hotels etc. and in workshops where large machines and other obstructions would cause trouble some shadows of direct lighting is employed.

## **v. General Lighting:**

- In this scheme lamps made of diffusing glass are used which give nearly equal illumination in all directions.

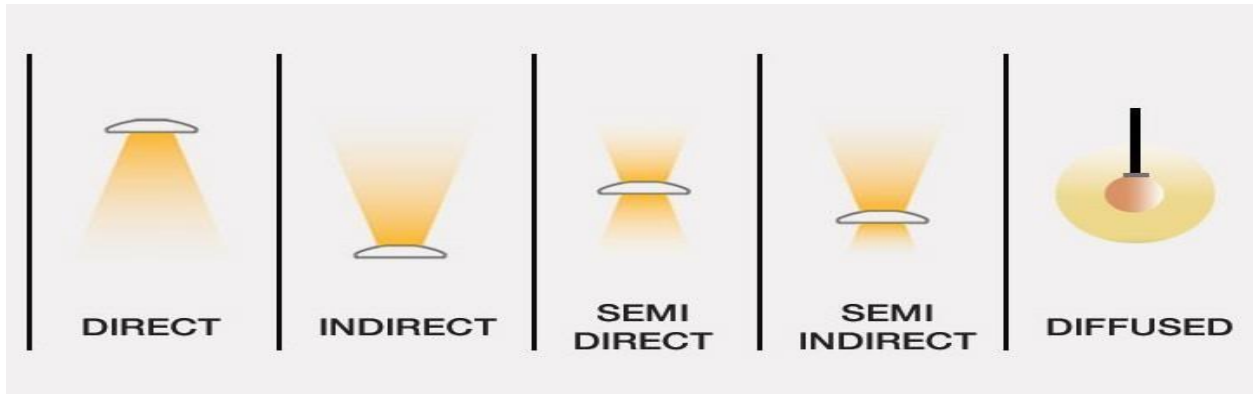

## Design of Lighting schemes

A well-designed lighting scheme is one which

- (i) provides adequate illumination
- (ii) avoids glare and hard shadows
- (iii) provides sufficiently uniform distribution of light all over the working plane.

Following factors are required while designing lighting scheme

1. Illumination level
2. Uniformity of Illumination
3. Colour of light
4. Shadows
5. Glare
6. Mounting height
7. Spacing of luminaries
8. Colour of surrounding walls

### ***i.Illumination Level:***

This is the most vital factor because a sufficient illumination is the basic means whereby we are able to see our surroundings. For each type of work there is a range of brightness most favourable to output i.e. which causes minimum fatigue and gives maximum output in terms of quality depends upon:

- (i) The size of the objects to be seen and its distance from the observer. Greater the distance of the object from observer and smaller the size of the object, greater will be the illumination required for its proper perception and

(ii) Contrast between the object and back-ground-greater the contrast between the colour of the object and its background, greater will be the illumination required to distinguish the object properly. Objects which are seen for longer duration of time required more illumination than those for casual work. Similarly moving objects required more illumination than those for stationary objects.

### ***ii. Uniformity of Illumination:***

The human eye adjusts itself automatically to the brightness within the field of vision. If there is a lack of uniformity, pupil or iris of the eye has to adjust more frequently and thus fatigue is caused to the eye and productivity is reduced. It has been found that visual performance is best if the range of brightness within the field of vision is not greater than 3:1, which can be achieved by employing general lighting.

### ***iii. Shadows:***

In lighting installations, formation of long and hard shadows causes fatigue of eyes and therefore is considered to be a shortcoming. Complete absence of shadows altogether again does not necessarily mean an ideal condition of lighting installations. Contrary, perhaps to popular opinion, a certain amount of shadow is desirable in artificial lighting as it helps to give shape to the solid objects and makes them easily recognised.

### ***iv. Glare:***

It may be direct or reflected i.e. it may come direct from the light source or it may be reflected brightness such as from a desk top, nicked machine parts, or calendared paper.

Direct glare from a source of light is more common, and is more often a hindrance to vision. A glance at the sun proves that an extremely bright light source causes acute eye discomfort. Reflected glare is glare which comes to the eyes as glint or reflection of the light source in some polished surface.

### ***v. Mounting Height:***

In case of direct lighting it depends upon the type of building and type of lighting scheme employed. For rooms of large floor area, the luminaries

should be mounted close to ceiling as possible. In case of indirect and semi-indirect lighting, it would be desirable to suspend luminaries enough down from ceiling to give uniform illumination.

**vi. Spacing of Luminaries:**

The distance of light source from the wall should be equal to one half the distances between two adjacent light sources. The distance between light fittings should not exceed 1.5 times the mounting height. In the case of direct and semi-direct luminaries the ratio of the horizontal spacing between rows to the height of the luminaries above the working plane depends to quite an extent on the candle power-distribution curve of the luminaire. With fluorescent luminaries it is good practice to aim at a value of unity for this ratio, and to set an upper limit of 3/4. In the case of tungsten lamps combined with focusing reflectors, the ratio of spacing to height should be about 0.6.

**Illumination level required, as per ISI, in various parts of a building is given below:**

<b>Location</b>	<b>Illumination Level in Lux</b>
Entrances, hallways	100
Living room	300
Dining room	150
Bed room General	300
Dressing tables, bed heads	200
Tables games	300
Games or recreation room	100
Kitchen	200
Kitchen sink	300
Laundry	200
Bathroom	100
Bathroom mirror	300
Sewing	700
Workshop	200
Stairs	100
Garage	70
Study	300

Illumination level required, as per ISI, for various types of traffic routes is given below

<b>Classification of Lighting Installation</b>	<b>Type of Road</b>	<b>Average Level of Illumination on Road Surface</b>
Group A <sub>1</sub>	Important traffic routes carrying fast traffic.	30
Group A <sub>2</sub>	Other main roads carrying mixed traffic like main city streets, arterial roads, through ways etc.	15
Group B <sub>1</sub>	Secondary roads with considerable traffic like principal local traffic routes, shopping streets etc.	8
Group B <sub>2</sub>	Secondary roads with light traffic.	4

**vii. Colour of Surrounding Walls:**

The illumination in any room depends upon the light reflected from the walls and ceilings. White walls and ceilings reflect more light as compared to coloured ones.

# OVER HEAD INSTALLATION

- Electrical energy is generated at the power stations (hydroelectric, thermal or nuclear)
- The transmission system is to deliver bulk power from power stations to the load centers & large industrial consumers.
- The distribution system is to deliver power from power stations or substations to the various consumers.
- The generation, transmission and distribution system of electrical power is called the electrical power supply system
- The maximum generation voltage in advanced countries is 33 kV while that in India is 11KV.
- The primary transmission voltages are 220-765 kV (220, 400 or 765 kV) depending upon the distance, the amount of power to be transmitted and system stability.
- Secondary transmission voltages are 33-132 kV (33, 66 or 132 kV).
- The voltages for primary distribution are 3.3, 6.6 or 11 kV most usual value adopted in practice is 11 kV.
- The usable voltage for secondary distribution is 415/240 V.
- The distribution system may further be divided into feeders, distributors and service mains.
  - a) **Feeders:** Feeders are the conductors which connect the stations to the areas to be fed by those stations. Generally from feeders no tapping is taken to the consumers, therefore, current loading of a feeder remains the same along its length. It is designed mainly from the point of view of its current carrying capacity.
  - b) **Distributors:** Distributors are the conductors from which numerous tapping for the supply to the consumers are taken. The current loading of a distributor varies along its length. Distributors are designed from the Point of view of the voltage drop in them.
  - c) **Service Mains:** Service mains are the conductors, which connect the consumer's terminals to the distributor.

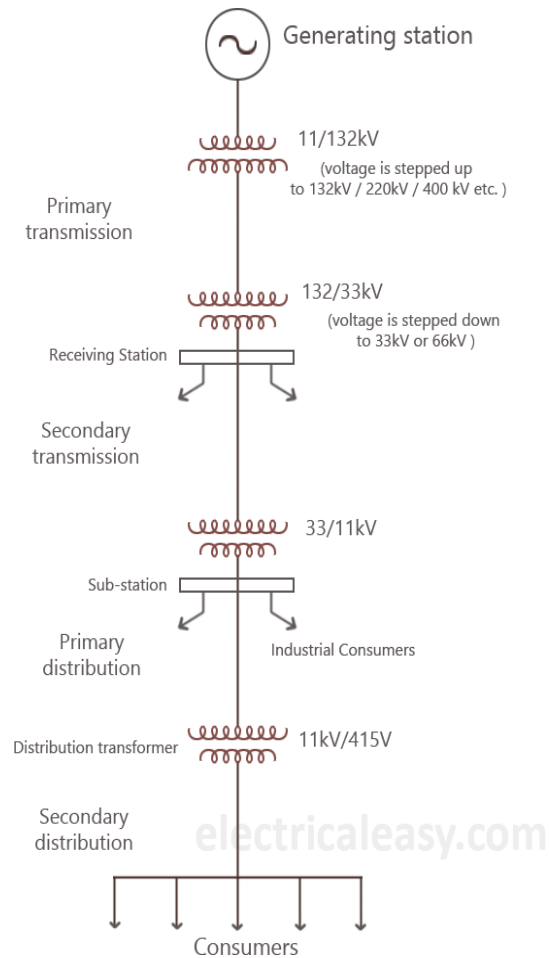



- The distributors is subjected to the legal requirement that the voltage drop at the consumers terminal should be maintained within **±6% of the declared voltage.**
- There is no such legal restriction on a transmission line and the voltage can vary as **10% or 15%** due to variation in loads.

### **Voltage classification**

As per the Indian Electricity Rules, 1956:

- Low Voltage AC: Not exceeding 1KV
- Medium Voltage AC: between 1KV & 33KV
- High Voltage AC(HVAC): Not exceeding 220KV
- Extra High Voltage AC(EHV-AC): between 400KV & 765KV
- Ultra high voltage AC(UHV-AC): exceeding 765KV
- HVDC : upto 1600KV

### **MAIN COMPONENTS OF OVERHEAD LINES**

- |  |                              |
|--|------------------------------|
| 1. Line Supports                       | 11. Fuses & isolating switch |
| 2. Conductors                          | 12. Vee -guards              |
| 3. Insulators                          | 13. Guard wire               |
| 4. Cross arm                           | 14. vibration damper         |
| 5. Pole bracket & clamps               | 15. Beads of jumpers         |
| 6. Stays & guys                        | 16. muffs                    |
| 7. Lightning arrester                  | 17. Earth wire               |
| 8. Anti climbing device or barbed wire |                              |
| 9. danger plate                        |                              |
| 10. phase plate                        |                              |

### **Line supports**

- The function of line support is obviously to support the conductors, insulators, & cross arm for overhead line..
- The main requirement of line supports are:
  - a) High mechanical strength to withstand the weight of conductor
  - b) light in weight without, the loss of mechanical strength.
  - c) Cheaper in cost,
  - d) Low maintenance cost.
  - e) Longer life,
  - f) Good looking
  - g) Easy accessibility for painting and erection of line conductor.
- Choice of line support depends upon
  - a) Line span
  - b) Cross sectional area
  - c) Line voltage
  - d) Cost
  - e) Local condition

- The different types of supports used for erecting overhead lines in urban and rural areas are:

1. Wooden poles.
2. Steel poles.
3. Re-inforced Cement Concrete (RCC) & Pre-stressed Cement Concrete (PCC) poles.
4. steel tower

### 1. Wooden poles.

- These supports are cheapest, easily available, provide insulating properties and therefore, are extensively used for the distribution purposes specially in rural electrification
- Their use is usually limited to low pressures (up to **22 kV**) and for short spans (up to **60 meters**).
- In districts having a plentiful supply of suitable timber and where the cost of transporting steel towers is high single and 'H' poles have been used for overhead lines operating at voltages up to **130 kV** and average span lengths of **150 meters**.
- Sal or chir wooden poles up to **11 meter** length with minimum circumference of **38 cm** at the top and **66 cm** at the bottom are used.
- To prevent decay owing to snow and the wooden poles are protected by an aluminium, zinc or cement cap at the top.
- For a pole length of 10 metres, the setting depth should not be less than **1.5m** in normal condition & **2 meters** in poor soil condition, is buried in the ground must be with the creosote oil or any preservative compound.
- The wooden poles well impregnated with the creosote oil or any preservative have life from **25 to 30 years**.
- There are different types of poles like straight pole, "A" poles, "H" poles, 4 pole structure.
- The depth of pole in ground depends upon many factors i.e. height of pole, soil condition, weight and pull factor if any
- The height of wooden pole depends upon clearance above ground surface and the number of cross arms & other equipment to be attached.
- Normally, the height of wooden pole is **10 to 12 m**.
- drawbacks of wooden supports are : smaller life, less mechanical strength and requirement of periodical inspection

### 2. Steel poles

- The steel poles are of three types
  - a) tubular poles
  - b) rail poles
  - c) rolled steel joists.

The tubular poles are of round cross section, the rail poles are of the shape of track used for railways and rolled steel joists are of "I" cross section

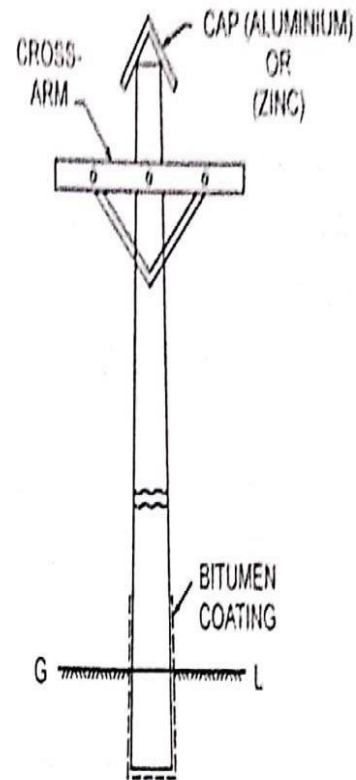
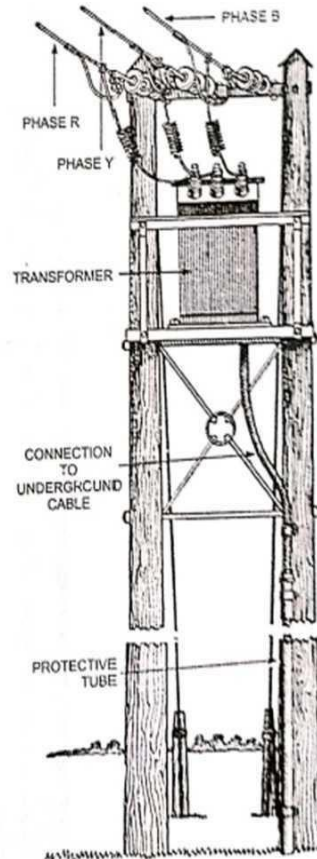
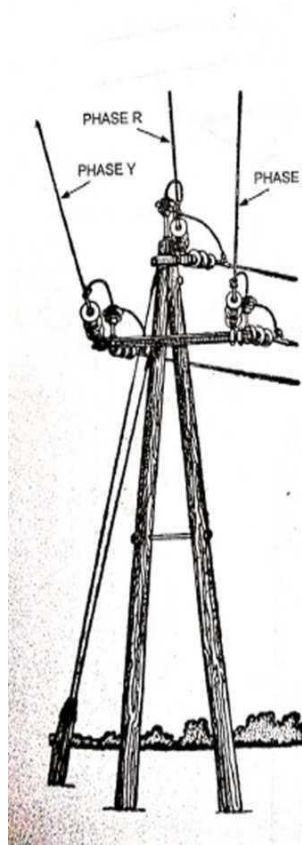

- Such poles possess greater mechanical strength and permit use of longer spans (**50-80 m**) but cost is higher.
- Their life is longer than that of wooden poles and life is increased by regular painting.
- These poles are set in concrete muffs at the foundation in order to protect them from chemical action.
- The average life of steel poles is more than **40 years**
- Tubular poles in height of **9 to 11m** are generally used for distribution purposes in cities
- steel rail poles in height of **11m** and **13m** are used for transmission purposes at 11KV & 33KV respectively.
- The depth of pole depend upon soil condition, no. of conductor supported etc.

Lenth of pole	Depth on normal soil condtion	Depth on poor soil condition
9m	1.6m	1.7m
10m	1.7m	1.9m
11m	1.9m	2.15m
12m	2.15m	2.4m
13m	2.4m	2.6m
14m	2.6m	2.8m

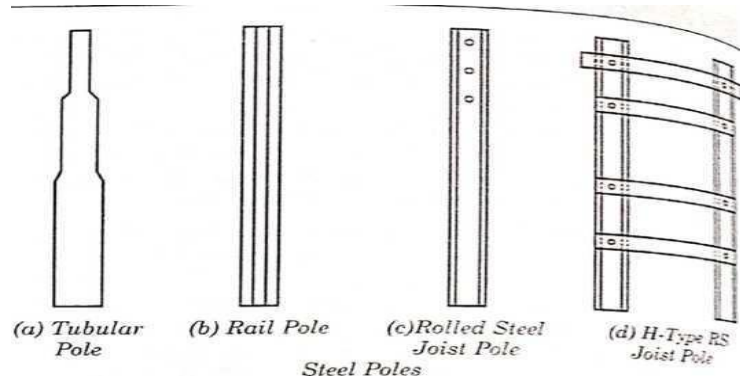

Steel Poles

### 3.Re-inforced Cement Concrete (RCC) & Pre-stressed Cement Concrete (PCC) poles.

- Poles made of reinforced cement concrete (RCC), usually called the concrete poles.
- used for low voltage and high voltage distribution lines up to 33 kV.
- Their construction should conform to the standard specification for RCC work, but in no case the dimensions shall be less **25 cm x25 cm** at the bottom and **13cm x 13 cm** at the top.
- These poles are of two types in shape. One is square cross section as whole & other is rectangular bottom square top with holes.
- These give good appearance, require no maintenance, have got insulating properties and resistance against chemical action, very strong, have longer life
- It can be used for longer spans (**80-200m**).
- Such poles are most suitable for water logged situations where other types will not be at all suitable, as due to standing water wooden poles will decay very rapidly, and steel construction will be having deposit of rust. Since these poles are very bulky and heavy, transportation cost is heavy and need care in handling and erection.
- Pre-stressed concrete poles, called the PCC poles, are less bulky and lighter than RCC poles. PCC pole are of **8m & 9m** length.
- PCC poles are extensively used on 11 kV and low lines.
- For a length of 10-metres of pole, **1.6 metres** will be set into pit of normal soil conditions and upto **2 metres** in case of poor or sandy soil.

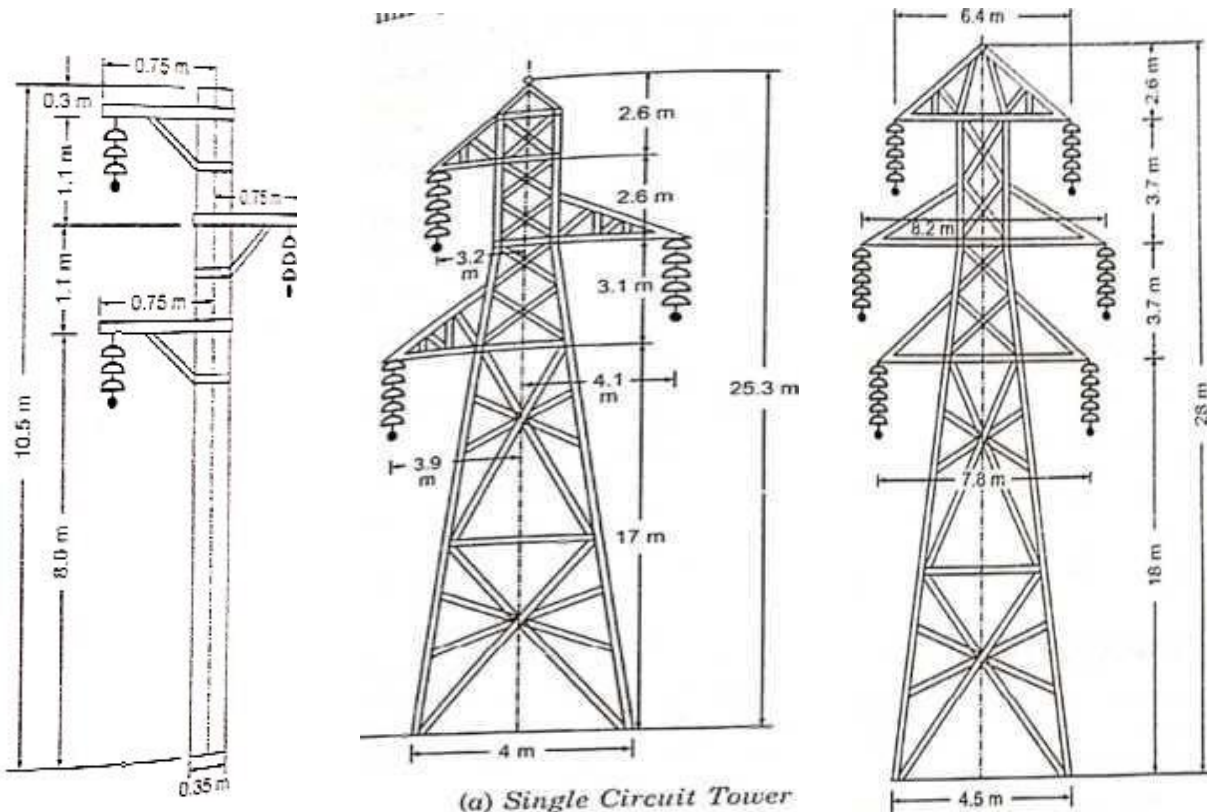

#### 4. lattice steel tower:

- Transmission lines are generally carried on steel towers.
- narrow-base, lattice-steel towers are used for transmission at 11 kV and 33 kV and broad-base lattice-steel towers are used for transmission purposes at 66 kV and above.
- The broad-base, lattice-steel towers are mechanically stronger and have got longer life.
- The usual span of tower line is **250 m**. but it can be used for **300m** or above span.
- A certain general rigidity in the longitudinal direction is provided for in practice by using rigid anchoring towers at an interval of **1.5 km** or so
- It can be used for crossing fields, valleys, railway lines, river etc.
- Even though these are two to four times costlier than wooden poles, yet for tall supports and longer spans these prove more economical.
- The substantial construction of the towers renders them capable of withstanding the most severe climatic conditions, and immune from destruction by forest fires.
- Lightning troubles are also minimised as each tower is a lightning conductor
- Steel towers are fabricated from painted or galvanised angle sections which can be transported separately and the erection done on site.
- In double circuit, In case of breakdown to one circuit it is possible to carry out repairs while maintaining the continuity of supply on the other circuit.
- The height of the tower depends; on the line voltage and length of span.
- The legs of the towers are set in special concrete foundations.
- Steel tower are of 2 types
  - a) Tangent tower-for straight or 2degree deviation run- suspension insulator used
  - b) Deviation tower-for above 2 degree deviation run-strain type insulator used

#### **FACTORS GOVERNING HEIGHT OF POLE**

The minimum height of poles, which can be used, depends upon the following factors

- a) The minimum clearance of the lowest conductor from the ground '
- b) The number of conductors to be carried and minimum vertical clearance between conductor
- c) The length of the pole to be buried in the ground (about one-sixth of the total length to be buried if the soil is normal).

#### **2. Conductors**

- The conductor material used for transmission and distribution of electrical energy must have the following characteristics :
  - i. High electrical conductivity i.e. low specific resistance.
  - ii. High tensile strength in order to withstand mechanical stresses.
  - iii. The conductor material should not be brittle.
  - iv. Low specific gravity in order to give less weight per unit volume.
  - v. Low cost in order to be used over long distances.
  - vi. Easily available

- Conductors used for overhead lines are preferably stranded in order to increase the flexibility.
- The stranded conductors usually have a central wire around which there are successive layer of 6, 12, 18, 24.
- For n layers, the total number of individual wire is  $3n(n+1)+1$ .
- If the diameter of each strand is d then diameter of the stranded conductor will be  $(2n + 1)d$ .
- In the process of manufacture adjacent layers are spiralled in opposite direction so that layers are bound together called `concrete lay` .
- Another method of spiraled called `rope lay` which give more flexibility.

### Types of conductors

#### 1. Stranded hard drawn copper

- Hard drawn copper conductor is best for transmission & distribution of electrical energy.
- Characteristics of Stranded hard drawn copper conductors are
  - a) high electrical conductivity
  - b) high tensile strength.
  - c) does not corrode in normal atmosphere & is not subjected to electrolytic troubles
  - d) higher current density so lesser x-sectional area
  - e) durable, long life and ease of jointing.
- Medium hard drawn CU is suitable for distribution line & soft drawn CU is suitable for secondary distribution or for service line connection.
- The difficulty of importing it due to lack of foreign exchange in our country, the trend nowadays is to use aluminium in place of copper.

#### 2. Aluminium

- Characteristics of Al conductors are:
  - a) cheaper than copper.
  - b) lighter in weight
  - c) poor conductivity & poor tensile strength
  - d) The diameter of aluminium conductor is about 1.26 times that of copper but due to its low density only half weight of aluminium is required to that of copper.
  - e) aluminium conductor has about 75% of the ultimate strength of equivalent copper conductor
  - f) For the same conductivity aluminium conductor having 1.66 times the x-section of copper is required thus causes a greater surface for wind pressure.
  - g) the sag is greater in aluminium wires.
  - h) At high voltage there is less corona loss.
  - i) Due to low melting point of aluminium it cannot withstand short circuits
  - j) . Jointing of Al is also difficult as compared to that of copper.



- k) Greater availability.
- All aluminium stranded conductor (AAC) or AASC(all Al stranded conductor) weighs only half as the equivalent copper conductor and cost per unit length is considerably less.
- All aluminium stranded conductors are used for low voltage distribution overhead lines having short spans of up to **65 m**

### 3. Aluminium Conductors Sled Reinforced (A.C.S.R.):

- It consist of a core of galvanized steel strand surrounded by Al strands.
- The cross-section of two metals arc in the ratio 1:6 but in case of high strength conductors, their ratio may be 1 :4
- Steel conductor are galvanized to prevent rusting & electrolytic corrosion.
- The steel, core bears greater percentage of mechanical stresses while the aluminium carries the bulk of current.
- The A.C.S.R. conductor being of high tensile strength and lighter in weight produces small sag and therefore longer spans can be used.

The ACSR conductor has a largest diameter other type of conductor of same resistance, so corona losses are reduced

- Stronger supports are required for a given span.
- The ACSR conductor gets deteriorated by atmospheric corrosion due to bimetallic action of zinc and the aluminium,
- The skin effect is very predominating in ACSR
- because of reduced corona losses critical voltage limit of the conductor can be raised by 30 to 50 %
- Because of use of larger span, the number of line supports may be reduced by 25%
- This is used for high voltage transmission where larger span i.e more than **100m** is required

### 4. Galvanised steel:

- These are used for extremely long span or for short line exposed to high stress.
- Most suitable for rural area line supplying at 11Kv voltage.
- Not suitable for transmitting large power over long distance because of
  - a) Its conductivity is lowest i.e. 13% that of copper.
  - b) It has high internal reactance.
  - c) It is much subjected to eddy current and hysteresis loss.
  - d) It is rusted in damp situations
- Use of this wire limited to telecommunication line, stay wire, earth wire, & guard wire, also used as binding wire

### 5. Cadmium Copper:

- Addition of 1 or 2% of cadmium in copper increases the tensile strength by 40% and reduces the conductivity only by 17% below that of pure Cu.
- Cadmium copper is costlier than pure copper



- Cadmium copper conductors are also used for telephone and telegraph lines where currents involved are quite small.
- 6. Copper clad steel:**
- It is obtained by welding a copper coating on a steel wire
  - It has large tensile strength
  - In this wire the conductivity of composite wire is 30% to 40% of copper conductor of equal diameter.
  - It is very suitable for river crossing or where extremely long span is required.
- 7. Phosphor bronze:**
- It is used where harmful gas like ammonia is present & for extremely long span
  - In this Phosphor bronze are added to cadmium copper.

### **Determination of Size of Conductor for Overhead Transmission Line**

- The size of conductor is governed by following factors:
  - a) Power to be carried.
  - b) Line working voltage.
  - c) Length of the transmission line,
  - d) Power factor of the load.
  - e) Permissible voltage drop in line.
- Other important aspects for overhead transmission line.
  - a) The minimum cross-sectional area of copper conductor is  $13 \text{ mm}^2$  or 8 SWG.
  - b) The minimum cross-sectional area for service line to be  $8.52 \text{ mm}^2$ .
  - c) The voltage variation at consumer's terminals should not exceed 5% of normal declared supply voltage for LT supply and 12.5% of normal declared supply voltage for HT supply
  - d) For service line the minimum size of ACSR to be  $6/1 \times 2.11 \text{ mm}$ .
  - e) The minimum permissible size of copper for lines other than service lines must be such as to have an actual breaking load of not less than 652 kg.

### **3. Pole bracket & clamp:**

- A pole top bracket is required for fixing the pin insulator on the top of the Pole, and is manufactured from MS flat of size 60 mm x 8 mm.
- Clamps are made of flat iron and used for fixing or holding service line stay wire, earth wire, shackle insulator, cross arm etc.
- In service line one end of clamp is made longer and provided with an eye section.

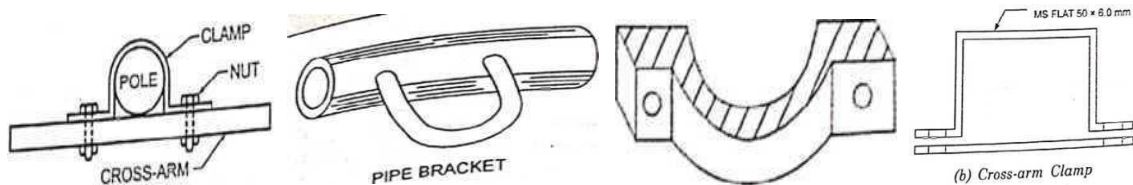

#### 4. Insulators:

- In order to prevent short circuit between the different phase conductors of the line and also to prevent leakage of current to earth through cross-arms on poles and towers, insulators are provided between conductors and supporting structures.
- Insulators are mounted on cross arm & line conductor are attached to insulator to provide proper insulation.
- It also provide mechanical support for line conductor.
- Important properties of over head lines are:
  - a) High mechanical strength
  - b) High relative permittivity
  - c) High insulation resistance
  - d) High ratio of rupture strength to flash-over voltage
  - e) Ability to withstand large temperature variations

#### Material of the Insulators :

##### 1) Porcelain:

- The material most commonly used for overhead line insulators is porcelain
- The porcelain is mixed with plastic kaolin, felspar and quartz, the mixture is moulded to shape and baked in a kiln at a controlled temperature
- The insulator so obtained is hard, smooth and glazed and free from porosity.
- It is mechanically stronger than glass.
- It gives less trouble from leakage and is less susceptible to temperature variations and its surface is not affected by dirt deposits
- Also fault cannot be detected easily as it is not transparent.
- it is not so homogeneous as glass
- The baking of insulators if done at lower temperature, its mechanical properties improve but the material remains porous and when it is put in service, it may deteriorate.
- If the material is manufactured at high temperature, its porosity decreases but the material becomes brittle.
- The suitable temperature in the kiln if obtained, it can produce better insulators. It will thus be mechanically strong and is not affected by sudden rise in its temperature.
- It is not so homogeneous as glass insulators, and its outer polish or glaze which is 1 to 2 mm thick improves its performance.
- This insulator is weak in tension and does not withstand tensile stress more than  $5\text{kg/mm}^2$ .
- The dielectric strength and compressive strength of mechanically sound porcelain insulator are about 6.5 KV per mm of its thickness and  $700\text{kg/mm}^2$

## 2) Glass:

- The glass is also used for making insulators.
- The glass insulators have the following characteristics :
  - a) They have high resistivity if properly annealed.
  - b) If properly toughened and annealed, they have high dielectric strength to the order of 14KV per mm of thickness of material.
  - c) The large size and great mass of glass insulator may result in internal strains after sudden rise in temperature and cooling. They have low coefficient of thermal expansion.
  - d) They have high compressive strength than porcelain insulators.
  - e) The glass insulators are cheaper than porcelain insulators.
  - f) They are quite homogenous and can withstand high compression stresses as compared to porcelain insulators.
  - g) The glass insulators being transparent, any flaw, impurities, bubbles etc. can be easily detected,
  - h) The main disadvantage of glass insulator is that the moisture easily condenses over the surface due to which dirt will deposit on its surface and will help to the leakage of current.
  - i) The use of glass insulators is not preferred for higher voltages due to reasons that the glass cannot be moulded to irregular shapes and internal strain may occur when sudden heat or cooling takes place
    - It can be used upto 25KV under ordinary atmospheric condition & 50KV in dry atmosphere.

## 3) Steatite:

- The steatite is a magnesium silicate found in various proportions of magnesium oxide and silica.
- It has much higher tensile and bending stress than porcelain, It can be used where insulator is in tension i.e. when the transmission lines take sharp turns.

## Various Types of Insulators:

### 1) Pin Type Insulators:

- They are economical, simple in construction and easy to install.
- The pin type insulators are used for telephone lines and overhead electric wire of low capacity on straight run.
- The conductor is placed in the top semicircular groove and tied along its neck with the help of a separate wire of the same material as the conductor in stirrup tie or re-inforced tie method, so that it remains intact even during storms and high pressure winds.
- The insulator is built up in various curved surfaced facing downward in order to increase the surface area to remain dry even during rain.
- The rain sheds (projections facing downward) are so designed that when insulators are wet even then sufficient dry surface is created by the inner sheds to avoid flash over and leakage of current.

- It can be used upto 33kv.

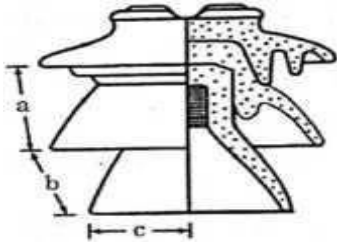

- Life of porcelain insulator is expected to 50 years.

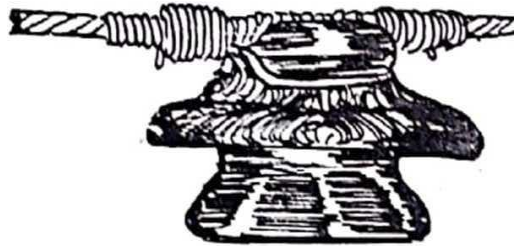

- Flashover distance for insulator =  $a+b+c$
- The ratio of spark over voltage to working voltage is 10(safety factor).
- It can be single or multi piece.

## 2)Suspension Type Insulators:

- This is the most popular insulator used for high voltage transmission above 66kv.
- It consist of a no. of porcelain disc flexibly connected in series by metal link in the form of a string.
- It hangs from cross arm of supporting structure & conductor is attached to its lower end.
- How many insulator the string consists of depend upon the working voltage, weather condition, type of transmission construction & size of insulator used.
- Beyond voltage 50kv pin type insulator become bulky, cumbersome & costly so disc type insulator is used.
- There are 3 types of suspension insulator
  - a) Hewlett or interlinking type
  - b) Cemented cap type
  - c) Core & link type

### Advantages:

- I. Cheaper in cost for operating voltage above 50 kv.
- II. Each unit of insulator is designed for low voltage about 11kv & can be used by connecting them in series depending upon working voltage.
- III. In case of failure one unit instead of whole string can be replaced.
- IV. Give more flexibility& mechanical stress are reduced
- V. With increase in voltage addition of more disc to string can be easily obtained.
- VI. In long span 2 disc insulator string can be yoked.

### Disadvantage:

- I. Large spacing between conductor are required

## Minimum Number of Insulator Discs for Transmission Lines

System voltage(kv)	No of insulator in string assembly	
	Suspension assembly	Tension or dead end assembly
11	1	1
33	2	3
66	5	6
132	9	10
220	14	15
400	21	22

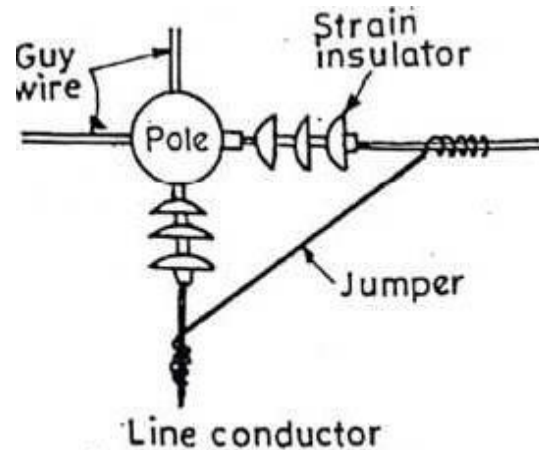
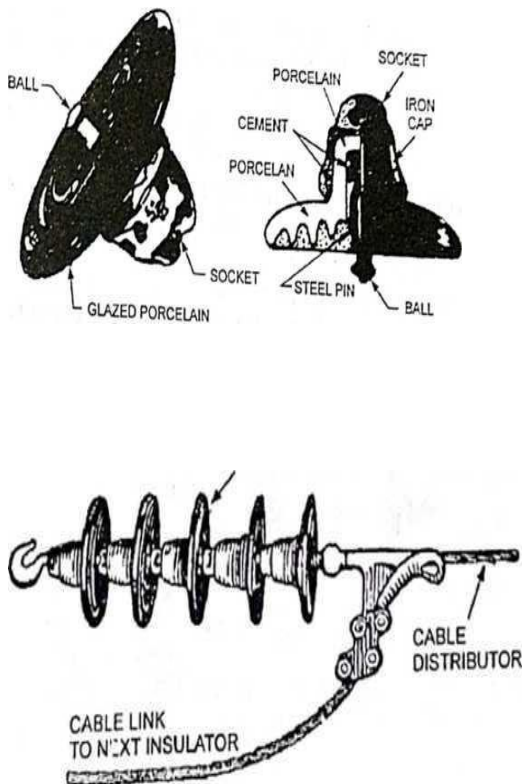

### 3) Strain Insulator :

- These are used at the dead end of the line or at sharp curve or line crosses river.
- These are used for high voltage line.
- The disc of strain insulator are used in vertical plane.

### 4) Shackle Insulators:

- The shackle insulators or spool insulators are almost universally used on low-voltage lines and provide a very neat efficient and economical arrangement
- every insulator is coated with an extremely hard, smooth glaze, that reduces accumulation of surface deposits.
- The surface can be easily cleaned and it will not crack when subjected to temperature changes

- The wet flash-over and dry flash-over voltages for shackle insulators are 10 kV and 25 kV respectively' while the puncture voltage is about 35 kV.
- Its operating voltage is 1.000 V.
- Its weight, transverse mechanical load and total creepage distance are 0.5kg. 1 150 kg and 63 mm respectively.
- The tapered hole in the shackle insulator distributes the load more evenly and reduces the possibility of breakage when heavily loaded.
- Shackle insulators may either be mounted horizontally or vertically
- The conductor are fixed in the grooves by means of soft copper or aluminium binding wire according conductor material.
- They can be directly fixed to the pole with a bolt or to the cross arm.
- It is used at all position, if the angle exceeds 60 degree deviation then it is used in conjunction with shackle strap.

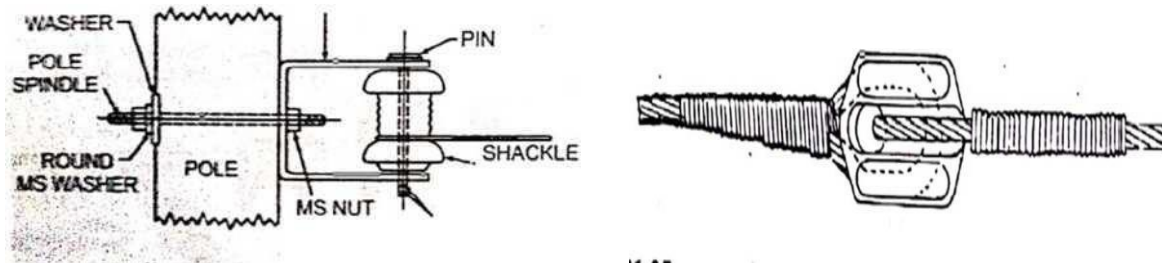

#### 5)stay insulator:

- The stay insulators are used on stay wire to create insulation between pole and stay clamp.
- For low voltage lines, the stay wires are insulated at a height of not less than 3 metres from the ground.
- Like other insulators it is also made of porcelain.
- The egg shaped insulator has two holes for the stay wires that in case of breakage of the insulator, the stay wire will not fall to the ground.
- It is of egg shape so called egg or strain or guy insulator.

#### 5.Cross Arms :

- Cross arms are mounted on pole to support the conductors and insulator of a line.
- It is a cross piece fitted to the pole top end portion by pole bracket for supporting insulator.
- Cross arms are of various types such as MS channel, angle iron or wooden these may be straight, U-shaped, V-shaped or zig-zag shaped.
- Wooden cross arms are commonly used on 11kv & 33kv lines. It made of sal, sheesam or creosoted fire wood.
- The usual length and cross section of wooden cross arm are: 1.5m×125mm ×125mm for 11kv and 2.1m×125mm×125mm for 33kv line.



- Wooden cross arm owing to decay after every 5-7 year depending upon weather condition.
- Steel cross arms are stronger and are generally used on steel poles.
- For Iv distribution the angle iron or channel iron cross arms shall be of size not less than 50 mm x 50 mm x 6.4 mm and 76 mm x 38 mm.
- The length of the cross arms shall be suitable for the spacing of the conductors
- To avoid birdage on ht lines. V-shaped cross arms are used with pin insulators while straight cross arms are used with disc insulators.
- The cross arm is fixed to the pole in such a manner that the load of the conductors is taken by the cross arm and not the clamp or bolt that fixes the cross arm to the pole.

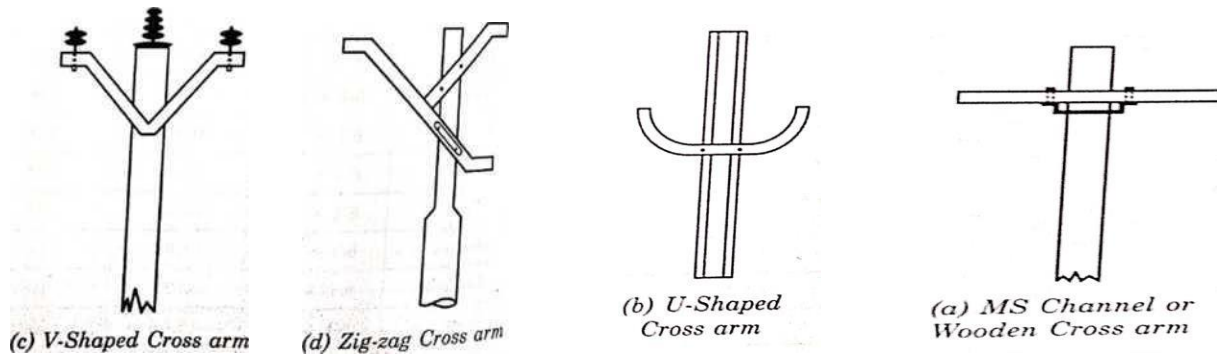

- The spacing between the conductor when swining should never be less than given below

Working voltage	spacing	Sag in cm	Horizontal spcing
6.6kv	76mm	Upto 75cm	30cm
11kv	101mm	76 to 120	45cm
33kv	190mm. and so on	121 to 145	60cm

### 6.PHASE PLATES:

- On each pole or tower of ht transmission lines phase plates indicating the different phases (red, yellow and blue) are provided.

### 7.DANGER PLATES:

- On each pole or tower of ht transmission line a danger plate indicating the working voltage of the line and word “danger” is provided at a height of at least 2.4 metres from the ground.

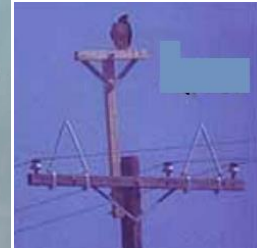
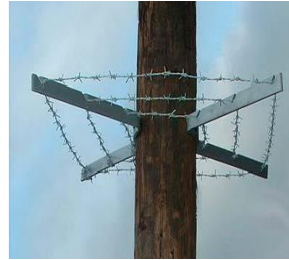
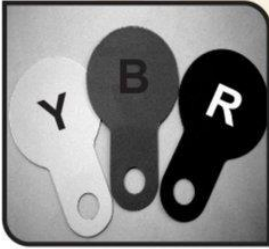

### 8. ANTI CLIMBING DEVICE / OR BARBED WIRE:

- GI Barbed wire is wrapped on poles at a height of about 2.5 m from the ground for atleast 1 metre. This is to prevent climbing by un authorised persons.
- On tower it is provided at a height of 3 to 4.5 m.

### 9. BIRD GUARD:

- These are in the form of wooden piece of size 10cm×12.5cm×15cm in case of metal pole.
- Used to avoid short circuit or earth fault due to sitting of birds.
- In tower these are of galvanised steel and of such shape that birds cannot sit on these.
- These are fitted on the top of the cross arm, just above the strain insulator.

### 10. BEADS OF JUMPER:

- To avoid birdage insulating beads are put all along the jumper.
- Because at certain places there are too many birds due to their touching the jumper & poles the failure of supply is most frequent.

### 11. MUFFS:

- These are used for concreting the poles or tower.
- It is made of 3mm thick sheet in two pieces, detachable 46cm× 46cm at the bottom & 30.5cm×30.5cm at the top & overall length 1.8m.
- For tubular pole these are of 25.4 cm dia & length of 1.8m.

### 12. Vibration damper/spacer:

- It is used to control vibration & oscillation of the conductor & earth wire, also maintain conductor spacing

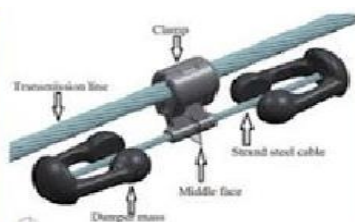



### 13. LIGHTNING ARRESTERS:

- These are devices to protect the electrical equipment from damage due to lightning
- A lightning arrester has open circuit during normal conditions and has no effect on the regular operation of the power system.
- When a voltage, high enough to damage the electrical equipment appears, the lightning arresters provide a low impedance path from the phase wire to earth and short the high voltage effectively.
- It provides a path through air gap for electric current between electric circuit & earth at the time of excessive voltage caused by lightning. So current will be not conducted because of air gap.

### 14. Guard wire:

- A guarding is provided for the safety of life, installations and of the communication circuits
- The guarding for 11 kV lines is provided at road crossing ,canal crossings, railway crossings, crossings over LT lines or telegraph and telephone lines. For LT lines, the guarding is provided throughout.
- Every guard wire should have sufficient current carrying capacity to ensure the circuit rendering dead, without risk of fusing of the guard wire or wires till the contact of any line wire has been removed
- There are various rule regarding guarding mentioned in IE rule no. 87 & 88
- When guard wires are provided, if a line conductor breaks, it becomes earthed before falling on the ground.
- There are two types of guards
  - a) cradle guard and (b) box or cage guard.

- In 11 kV lines, when conductors are in horizontal or delta formation, cradle guard is provided. The cradle guard is directly connected to earth wire. If the line conductor breaks, it will fall on the guard, thereby blowing the fuse or tripping the a circuit breaker.
- Cage guarding is provided on LT lines with vertical formation In It lines guard is connected with the neutral and insulated from the earth by means of porcelain reel. In case a live conductor breaks it comes in contact with the guard which causes a short circuit between the live conductor and neutral causing the fuse to blow or the circuit breaker to trip
- Guards should be made of the same material as used for the earth wire. Guards should be uniformly spaced.

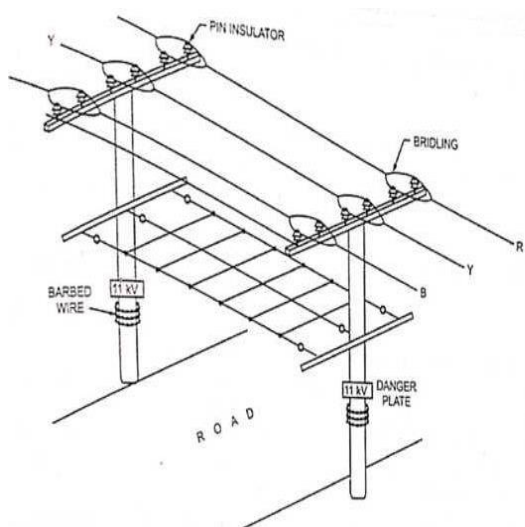
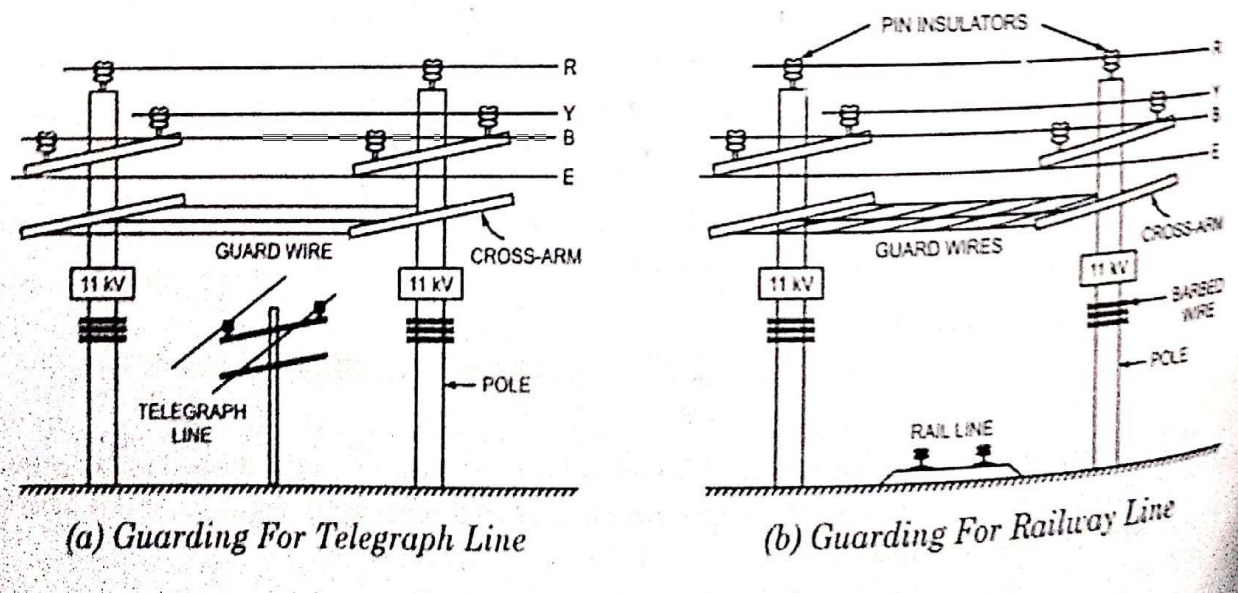

**Cradle guard**

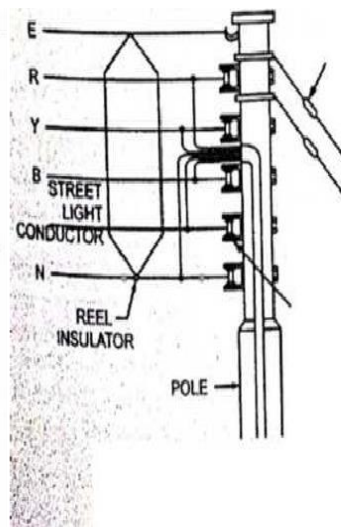

**Cage guard**

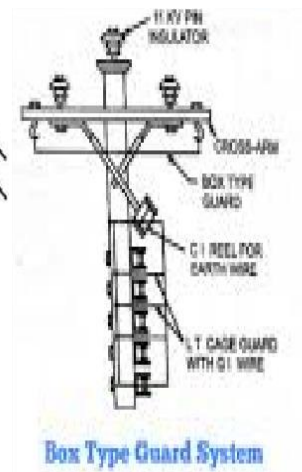

## 15. guys & stays:

- In case of an overhead line using poles, unlike intermediate poles a terminal pole experiences a pull on one side only and tends to tilt the pole in the direction of line. There is also a tendency for the pole to tilt where the line takes a turn. To prevent this, a stay or guy is provided.
- Under abnormal weather conditions the poles and conductors may be subjected to high velocity winds in the transverse direction to the line which may tilt or uproot the poles. As a safeguard against this, every **fifth** pole in a straight run provided with **2** stays on either side.
- The angle between pole & stay should be **45 degree** & the minimum angle between pole & stay is **30 degree**.
- A guy may be strut or stranded stay wire
- The strut guys which are made of line poles, are installed on the same side as conductors and take compressive loads.
- Stranded steel wire guys are fixed on the opposite side of conductor and they remain in tension.
- Stay set consist of MS stay rod of **16,19 or 20mm** diameter, stay bow, thimble, stay clamp, egg type insulator, stay wire of **7/8 SWG** GI wire, CI anchor plate, nut bolt etc
- The slay plate is fitted to one end of the stay rod and to the other end, the stay bow is fixed.
- Stay plates are of cast iron or reinforced concrete and it holds the stay (guy) assembly firmly in the ground. Except plate all other part are galvanised.
- Stay bow is a fixture which connect stay wire to stay rod.
- GI or MS thimbles are used at both ends of the stay (guy) wire to avoid damage to the strands of stay wire.
- Stay is fixed with the pole through a stay pole clamp by well spliced joint .
- An egg type insulator is inserted in each stay to insulate the upper part of stay wire from lower part. It is provided on the stay-wire at a Minimum height of **3 m** from the ground.
- Stay rod is embedded in cement concrete **1:3:6** to a depth of not less than **1.67m** keeping 46cm length of rod above ground, so that the stay wire does not come in contact with soil
- Stay wires are placed on the poles and stay rods are fixed before stretching of line conductors on the poles.



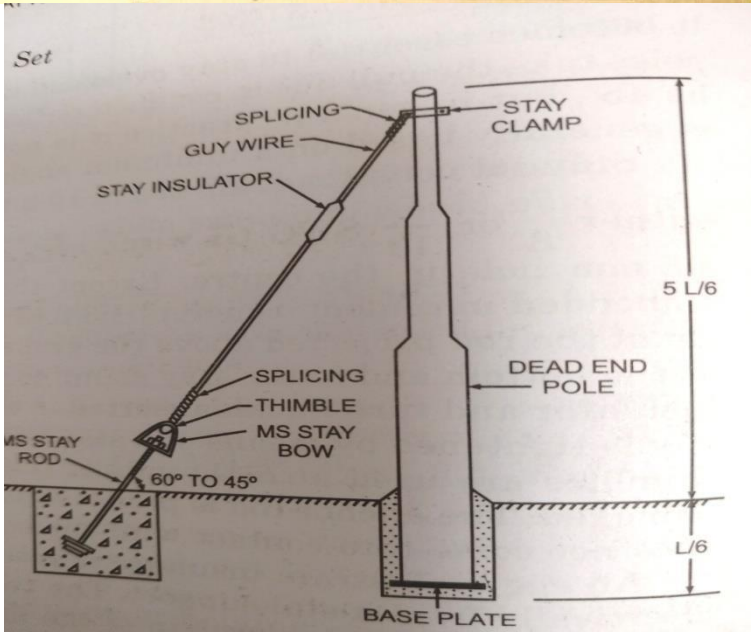
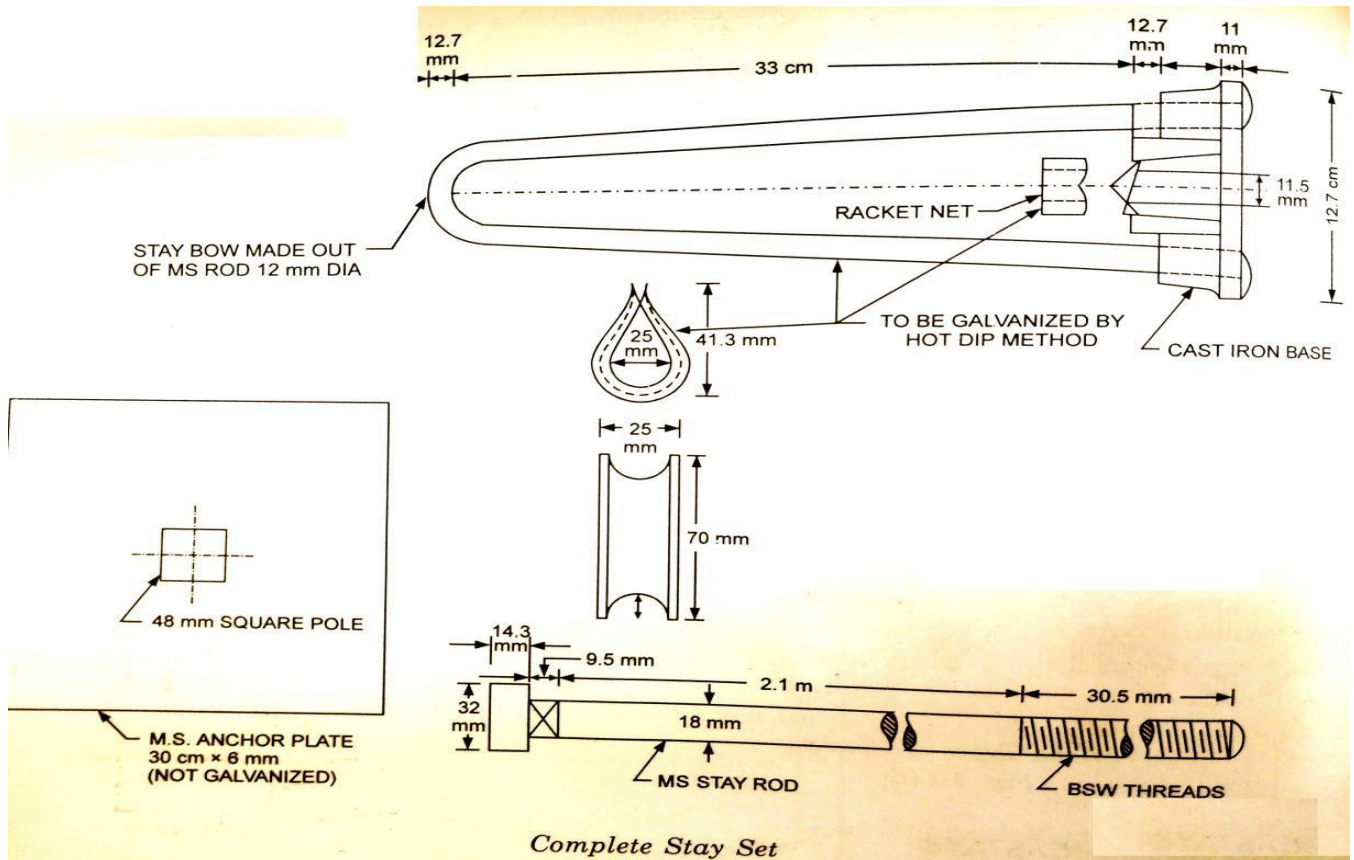



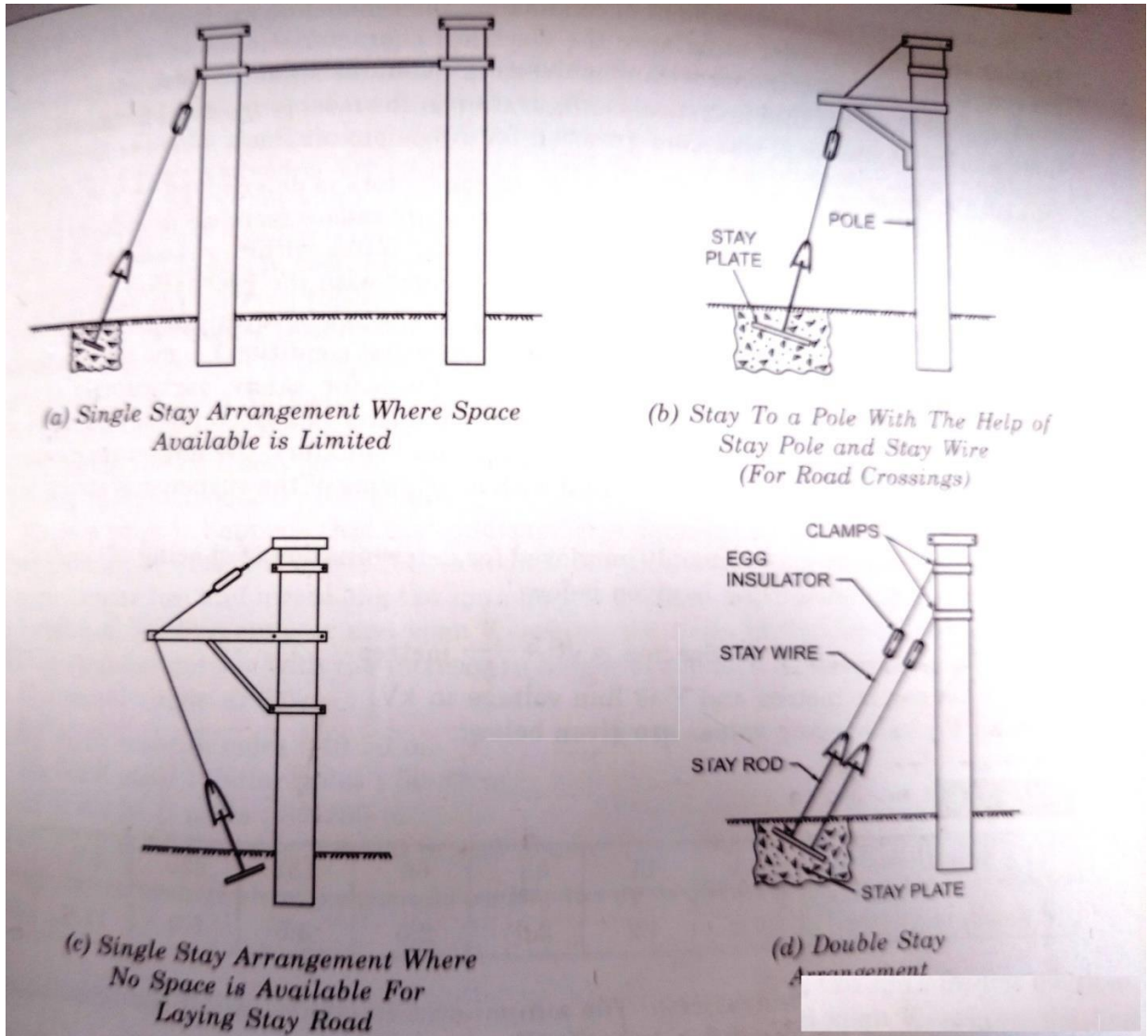

## 16. JUMPERS:

- In a straight run, one terminal pole is provided after every one kilometer so as to facilitate sagging.
- The short length of the conductor employed to connect the line conductor on one side of the terminal pole to the line conductor on the other side of the terminal pole is known as the jumper.
- A jumper is made of the same material and has the same current carrying capacity as that of the line conductor.
- It is fixed to conductor with suitable clamp.
- PVC sleeves or porcelain beads are provided on jumpers to avoid birdage.

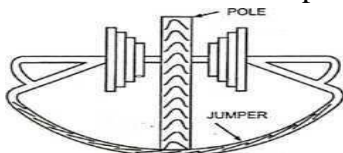

### 17. TEE-OFFS:

- tee-off from a line should be taken only from a pole and not in the middle of the span
- While taking branch line from an existing line for supplying villages/farms etc, it is essential that the correct phasing, phase-to-phase clearance and phase-to-earth clearance are observed.
- Dissimilar material should not be directly connected. Where metals such as CU & AL are to be Joined a special connector with an interaction fibre washer should be used.
- Parallel groove clamp are used for connecting similar conductors at branch positions.

### 18. Parallel Groove (PG) Clamps:

- These clamps are used at location in overhead system where the jointed conductors are not under mechanical stress
- The clamps are made of specially treated non-corrosion AL alloy in two pieces and provided with galvanized steel nuts, bolts and washers.
- PG clamps are extensively used for jumpers and tee-off connections

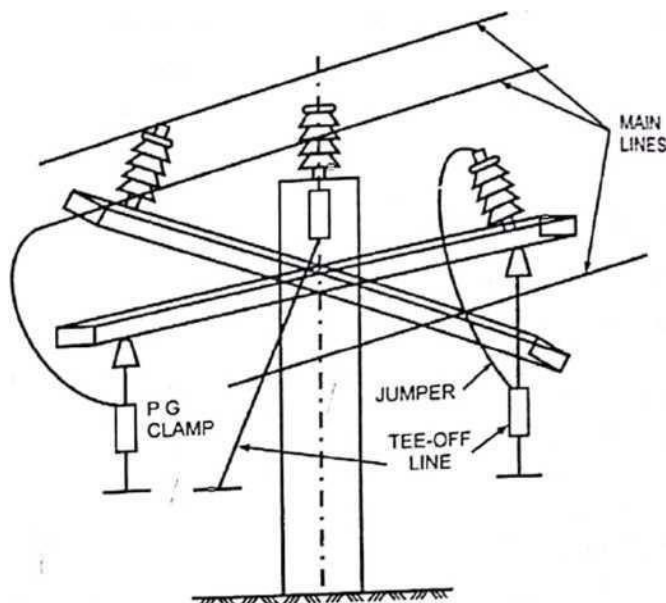

### 19. Miscellaneous:

- binding tape & binding wire: The conductors are bound to pin insulators using binding tape and binding wire..
- jointing sleeve: When two conductors have to be joined a jointing sleeve is used.
- repair sleeve: Repair sleeves are used for the reinforcement of ACSR or AAC conductors which have a few of the aluminium strands damaged or broken.

## 20. EARTHING OF TRANSMISSION LINES:

- The earthing is done to ensure that no current carrying conductor rises to a greater potential with respect to general mass of earth than its designed insulation and to ensure that the potential of non-current carrying metal work does not rise to a value such that a person may get shock on touching it.
- The supply system neutral point is earthed at power station or substation & All metal supports of overhead lines and metallic fittings attached thereto should be permanently and efficiently earthed
- Earthing can be done in two ways
  1. A continuous earth wire is run over the supports and then connected to earth at 4 points in every 1.6 km, the spacing between the points being as nearly equal as possible.

Double earth wire is used at those places where guarding is to be provided for a three-phase 3 wire system. The earth wire is placed in J-bolt or screw-eye bolt. At other places on 11 kV lines, the earth wire is placed on reels.
  2. In the second method, every pole is earthed and the earth wire is run along the pole to the ground & connected to the earth rod/pipe
- The arrangement of earthing of transmission line supports is as follows
  - i. The earthing shall be done with 2.5m long,25mm dia GI pipe, by driving it vertically inside the ground for its full length with top at least 0.6m below ground level.
  - ii. In case of moist earth if earth resistance is not less than 5 ohms by using 2.5m long pipe then increase length or diameter of pipe.
  - iii. The contact surface of support should be cleaned of paint,rust etc.
  - iv. The GI nuts and bolts should be properly tightened so that good contact is obtained.
  - v. GI washers should be used with each bolt.
  - vi. GI lugs employed should be properly soldered with the GS wire no 6 for end connection with the pipe and support
  - vii. MS clamps should be used for earth connections with steel tubular poles. The clamp should fit tight on the pole.
  - viii. MS or wooden lugs may be used to facilitate hammering on pipe for driving it inside ground.
  - ix. For steel tubular poles, a hole of 14 mm diameter is provided in each pole at a height of 300 mm above the planting depth for connecting the earth wire to the earth electrode.
  - x. For earthing of RCC/PCC supports the wire (GI No. 6 SWG) for earthing brought from the top along the support should properly be clamped and connected to earth electrode directly.

- xi. charcoal and salt layers are provided around the pipe/rod in alternate layers & Water is poured into the sump to keep the soil surrounding the pipe moist to reduce earth resistance which should not exceed 10 ohms.

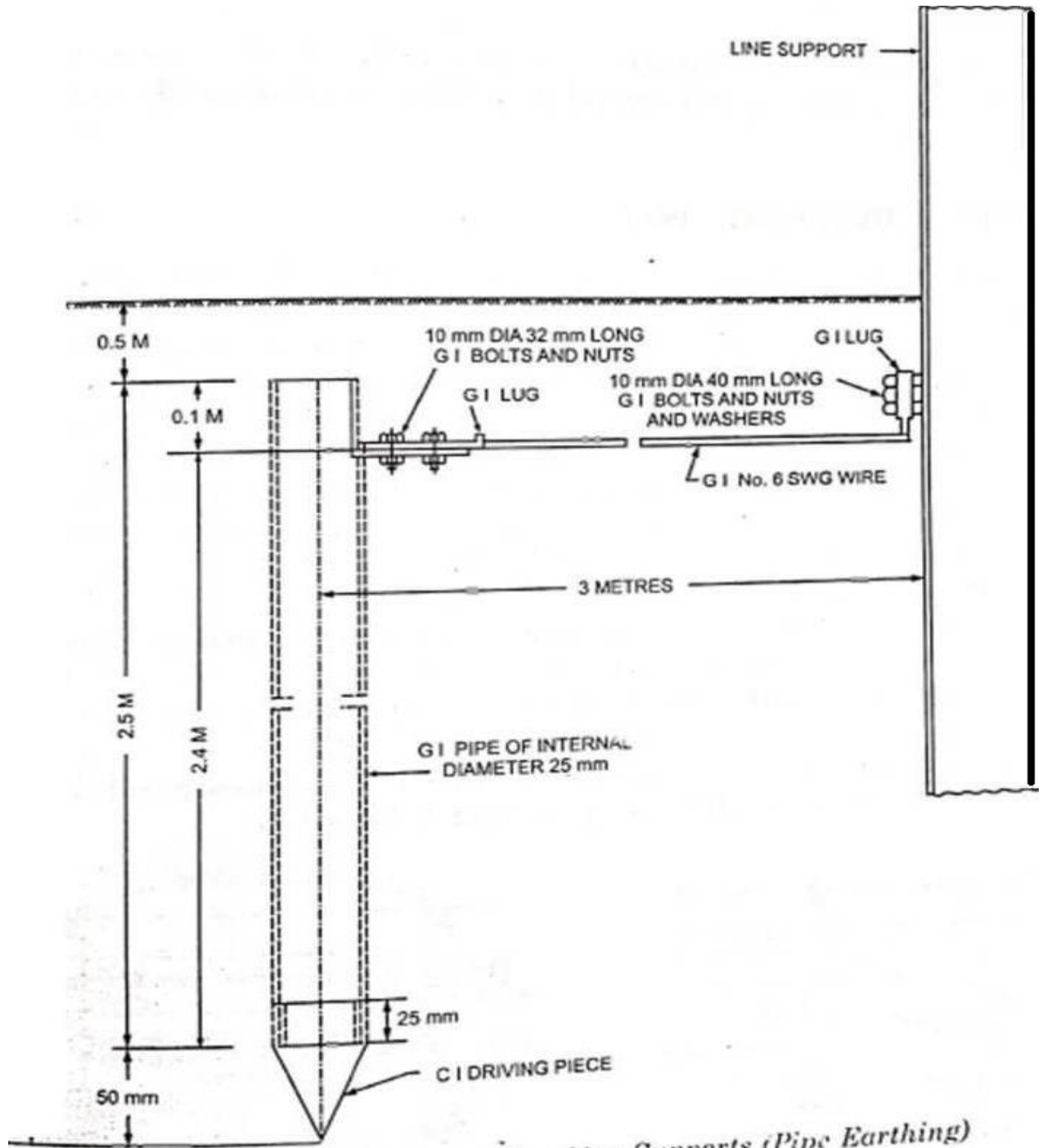

*Earthing of Transmission Line Supports (Pipe Earthing)*

## CONDUCTORS CONFIGURATION:

- there are three most common configurations are
  - A. horizontal configuration
  - B. vertical configuration
  - C. Triangular or delta configuration
- **In** horizontal configuration all the conductors are mounted over one crossarm & economical for single circuit line.
- **In** vertical configuration conductors are along the Length of pole one below the other, require taller tower & more lightning hazards occur. Economical for double circuit lines.
- **In** Triangular or delta configuration pin type insulator is required
- In unsymmetrical arrangement of conductors, conductor are transposed at regular interval in order to balance the electrical characteristics of various phases, and prevent inductive interference with neighboring communication circuits.

## CONDUCTORS SPACING :

- Spacing of conductors is determined by considerations partly electrical & mechanical.
- Large spacing causes increase in inductance & voltage drop & corona increases.
- The minimum clearance to supporting structure should be 45 degree swing of suspension string towards the structure.
- Formula for determination of spacing of conductor for AL conductor line is

$$\text{Spacing} = \sqrt{S + V/150} \text{ meters}$$

S is sag in meters & V is line voltage in KV

Line voltage in kV	0.4	11	33	66	132	220	400	765
Spacing in metres	0.2	1.2	2.0	2.5	3.5	6.0	11.5	14

## CONDUCTORS CLEARANCES: Acc. to IE rule no.77

<b>KV clearance to ground in meters</b>	<b>Line voltage in</b>							
	<b>0.4</b>	11	<b>33</b>	66	132	220	400	
<b>Across street</b>	<b>5.8</b>	<b>5.8</b>	<b>6.1</b>	<b>6.1</b>	<b>6.1</b>	<b>7.0</b>	<b>8.4</b>	
<b>Along street</b>	<b>5.5</b>	<b>5.5</b>	<b>5.8</b>	<b>6.1</b>	<b>6.1</b>	<b>7.0</b>	<b>8.4</b>	
<b>Other areas</b>	<b>4.6</b>	<b>4.6</b>	<b>5.2</b>	<b>5.5</b>	<b>6.1</b>	<b>7.0</b>	<b>8.4</b>	

### **Span length:**

- the length of the span depends upon the working voltage of the system, configurity of roads, railways or canals.
- The usual spans are :
  - (a) With wooden poles : 40-50 m.
  - (b) With steeltubular poles : 50-80m.
  - (c) With RCC poles : 80-200 m
  - (d) With steeltowers : 200-400 m and above.
- For river-crossings etc exceptionally long spans up to 800 m or so have been satisfactorily employed.

### **POINTS TO BE CONSIDERED AT THE TIME OF OVERHEAD LINE**

- Continuous ground wire earthed at the substation should be provided. Every 4<sup>th</sup> pole & 1<sup>st</sup> & last pole should be properly earthed and wire should be joined properly to continuous earth wire.
- Clearance of conductor from ground & adjoining should be acc. To IER 77,78,79 & 80.
- All metallic parts line components (except the main line conductor) should be earthed properly according to IER 90.
- Permissible spacing between the conductors should be maintained throught the lines
- Anti-climbing device and danger plate (or caution notice) should be fixed on each pole
- One-sixth of the pole length should be properly buried and rammed in soil
- The joints of the conductor should be mechanically strong and in proper sleeves
- The conductor should be tightened on the insulator properly with binding wire
- Guard wires should be provided where essential.
- Pole steps should be provided in the towers for the lineman to climb the poles
- Proper jumper should be used wherever required.
- The points to be kept in view in the design of an overhead line are .
  1. The line should be able to meet the desired load demands efficiently
  2. The line should be able to withstand adverse atmospheric condition
  3. The voltage drop along the line should be within prescribed limits(IER 54)
  - 4 .The cost of the overhead line should he tolerable.



## OVER HEAD SERVICE LINES

- The overhead line or cable connecting the supplier's distributing line to the consumers premises is called service main or service line or service connection. The service connection terminates at the point, where the supply conductors enter the meter.
- For single phase supply the service line has three wires namely phase, neutral wire and earth wire,.
- For 3 phase supply the service line has 5 wires namely three phase wires, fourth neutral wire, 5<sup>th</sup> earth wire, running from the supply pole to the consumer's premises.

### **Meter Board or Service Board.**

- The service line is provided with fuse kit-kats before it enters direct into the meter for protection of meter against extra high voltage or line surges.
- In view of the recent findings of the electricity authority it has been felt that the fuse kit-kats should be provided after the meter to eliminate chances of theft of electricity.
- The cut-out is provided on the phase wire and the neutral link on the neutral wire. The board on which the cut-out, neutral link and the meter are fitted is called 'Service Board'.
- The consumer's service connection terminates at the meter board and responsibility of electrical fittings and accessories beyond the meter is all of the consumer's own. The meter is sealed by the electricity board. The service board is fitted at a place which is covered, suitable to the consumer and at the same time easily accessible for inspection and meter reading purposes.

### **Service Conductor or Service Cable.**

- The service connections are given either by bare conductors of AAC(all aluminium conductor),ACSR, hard drawn copper or by weather proof cables of aluminium or copper..
- The size of the conductor depends upon the load of the consumer and distance up to service pole for voltage drop calculations to determine the correct size of service conductor. As such, the consumer with heavy loads are supplied power through heavy conductors.
- For cu conductor minimum size used is 10 SWG provided the load does not exceed 1 kW.
- 8 SWG copper conductor or 13.9 mm<sup>2</sup> AAC or ACSR conductor is used for domestic/commercial loads not exceeding 2.5 kW.
- For connecting power loads up to 12 kW, 6 SWG CU or 19.4 mm<sup>2</sup> AAC or ACSR conductors are used.
- Low tension 31/2 core cable is used for underground service connections.

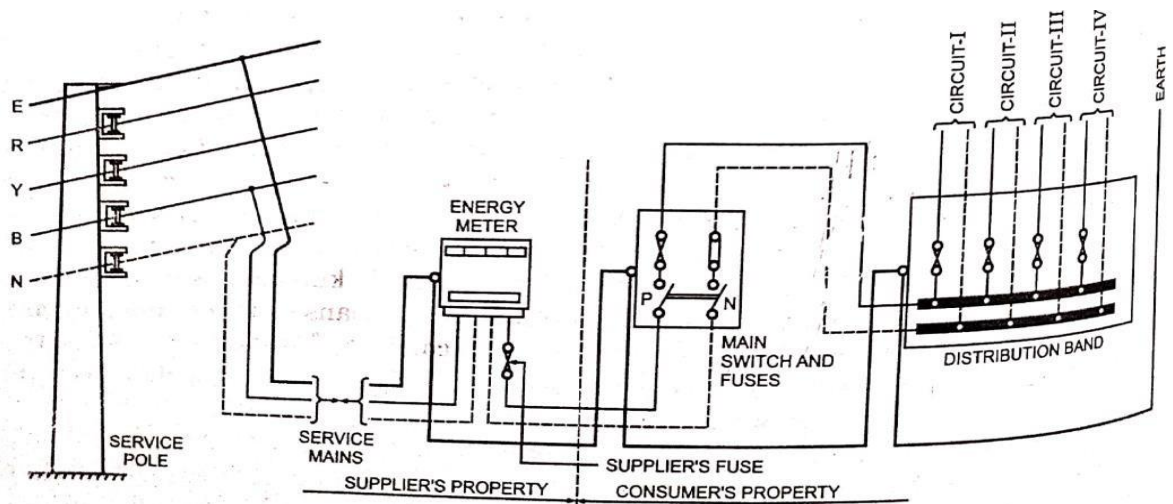

### Types of Service Connections.

The type of connection to the house or factory depends upon the type, requirements of power and distance of consumer's premises from service pole.

- Service lines are of two types
  - a) overhead service line
  - b) Underground service line

#### **a. overhead service line**

- for over head service connection refer IE rule no. 58,77 &79
- Bare overhead conductors are used for the service line when the consumer's premises are more than 45 meters away from the supplier's distribution pole.
- When the distance of the consumer's premises is less than 45 metres from the distribution pole the service line is a weather proof or PVC cable.
- This means that the overhead service line may be either PVC or weather proof cable or even bare conductors.

**(a) PVC or Weather Proof Cable Service Line:** When service connections are given to a single storey building by means of a PVC or weather proof cable, a GI wire of at least 8 SWG is stretched between the pole and a clamp or eye screw bolt fitted to a GI pipe raised above the roof of the consumer's building at a height as required by the Indian Electricity Rules .The weather proof or PVC cable is clipped along the GI wire stretched between the pole and the building. The service line then enters the GI pipe or wooden batten or HG conduit.

**(b) Bare Conductor Service Line:** When service connections are to be given to a single storey building by means of bare conductors, the bare conductors are brought from the nearest distribution pole to a shackle insulator clamped to a GI pipe at a suitable height .Connections from the bare conductors may then be taken by means of weather proof or PVC cable through the GI pipe. Thereafter, the service connection may be taken to the service board through GI pipe or on batten

The upper end of the GI pipe where the service cables enter, is bent down-wards to prevent entry of rain water.

**b. Underground service line**

- This connections are used when it is desired to avoid the sight of wires passing over the consumer's premises or when the consumer's load exceed 25KW.
- Paper insulated cables or PVC cables are used as the service cable
- For installation of underground cable service connection, a cable box of suitable size is fitted to the service pole by means of M.S. channel of size 16 mm X 25 mm and bolts and nuts.
- The cable is carried from the cable box fitted on pole to another cable box fitted on service board, first along the pole to the ground, then in the trench (one metre deep approx) and lastly vertical along the wall to the second cable box.
- The trench starts from the service pole and terminals vertically below the service board.
- Use of G.I. pipe of suitable size is made upto 2 metres from the ground for enclosing the cable in order to save it from mechanical damage at both places i.e. along the pole and below the service pole.
- The cable is held to pole by clamps

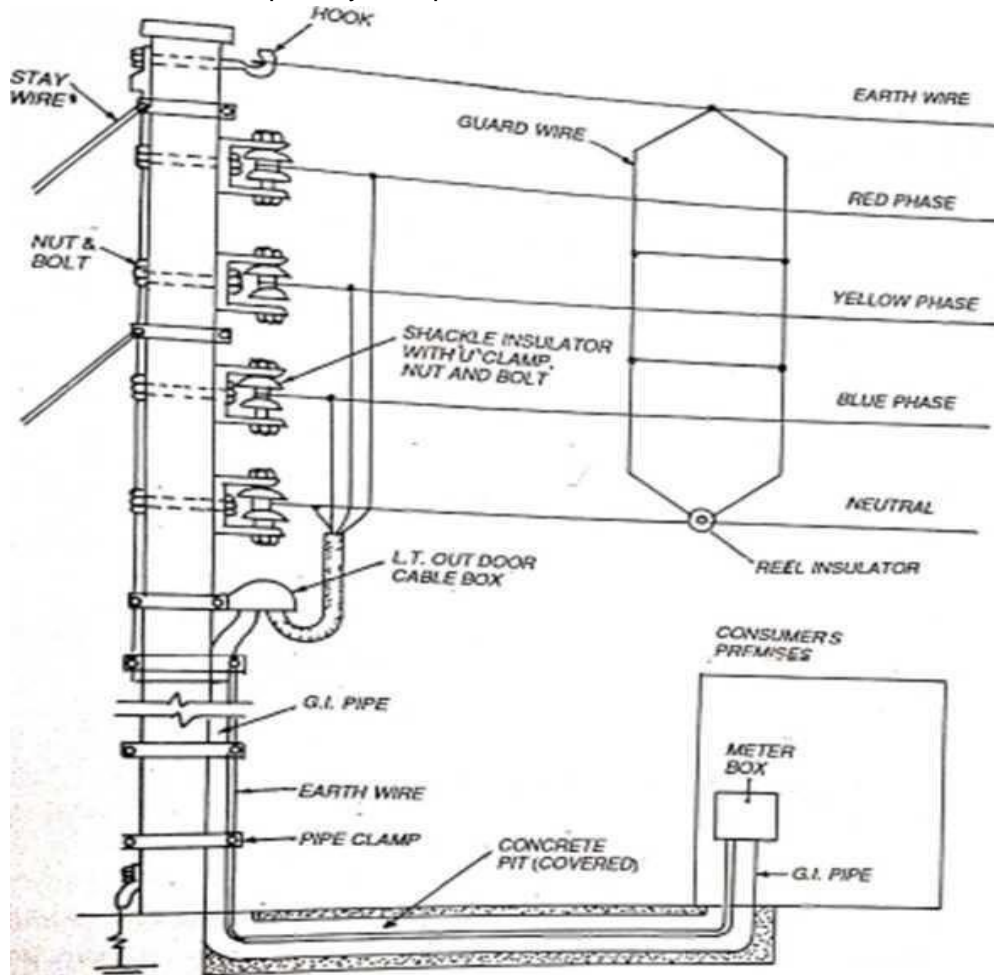

## METHODS OF INSTALLATION OF SERVICE LINES

### a) For High Roof Building:

- The wire may be connected to gable provided the building has necessary height or in case of no gable a service bracket (mild steel angle iron ) is installed & fitted to the corner of wall at a suitable height.
- The pin type or shackle type insulator are fitted to this wall bracket. No. of insulator depends upon the no of incoming wire
- As per rule vertical distance between insulator should be 35cm.
- The phase & neutral wire are taken from existing service pole and connected to insulator
- Earth wire connected to angle iron with the help of eye bolt.
- Now weather proof cable or PVC cable is connected to conductors and carried either on wooden batten or inside a GI pipe or conduit to the service board.

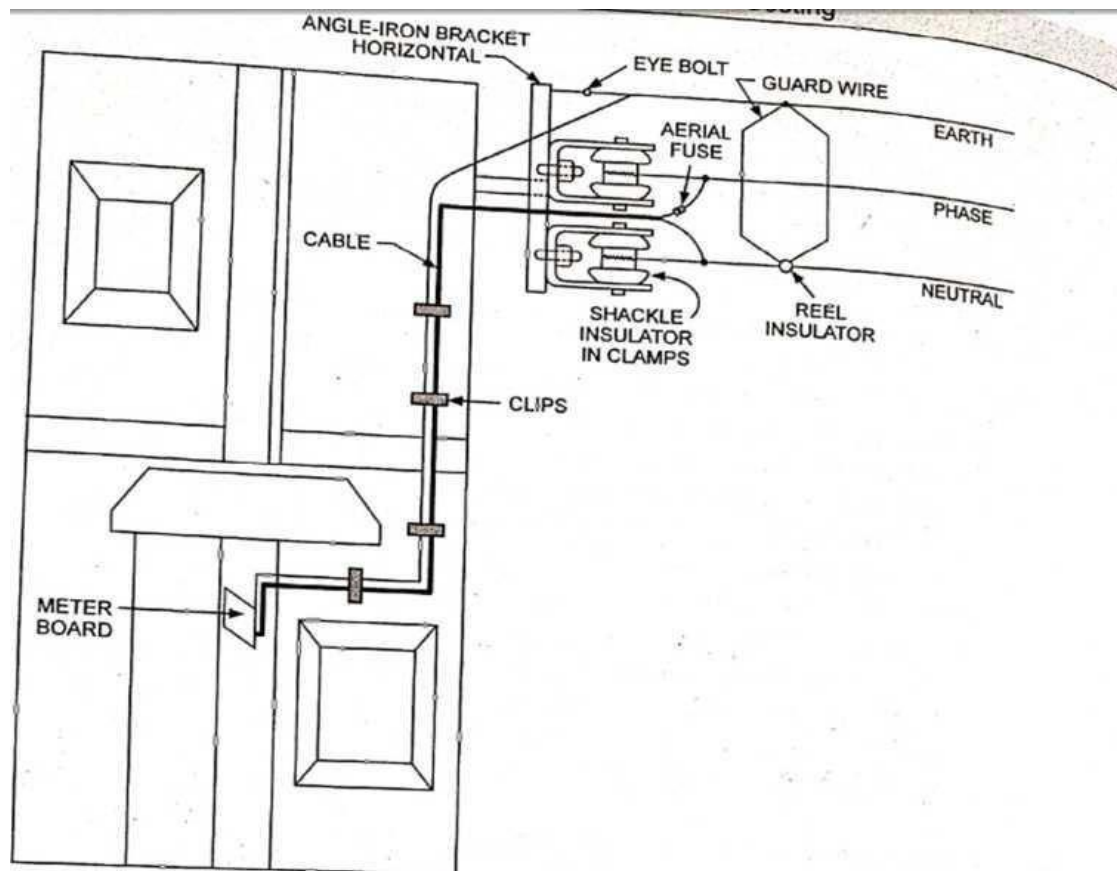

### b) For Low Roof or Single storey building:

- According to Indian electricity rules, the height of power conductor from ground should not be so close that the electricity rules are infringed.
- In this case 2 method is used
  - I. Roof pole or angle iron support
  - II. GI pipe

### i. Roof pole or angle iron support:

- In this case a strong steel tube or angle iron bracket provided with arms on which insulator are mounted
- The height of roof pole should not exceed 3m. otherwise tensile stress will become too high.
- To keep tensile stress low, the roof pole is braced by a steel rope or stay

### ii. GI pipe

- A GI pipe is fixed to the wall and raised upward above the roof to receive the service conductor which must have necessary clearance from the ground as laid down in Indian Electricity Rule No. 77 and 79.
- The GI pipe is fixed to the wall with suitable clamps.
- At its top, it is bent back such that its opening faces downward .this bend is provided to prevent rain water into the pipe.
- Sometimes, a wooden bush is inserted into opening so at the reptiles vermins etc. do not enter the pipe which otherwise may enter and cause damage to wires in the service pipe.
- A service bracket (angle iron) is attached to the G.I. pipe with clamps.
- The shackle insulators are attached to this bracket. The service conductors are attached to the insulators.
- The service connections are taken to the service board through G.I. pipe.
- The earth wire to the meter board runs along the outer surface of the G.I. pipe. The height of the conductors from ground is around 6 meters based on ground clearance as laid down in IER No. 77 and 79.
- To keep tensile stress low, the GI pipe is supported by a stay wire.

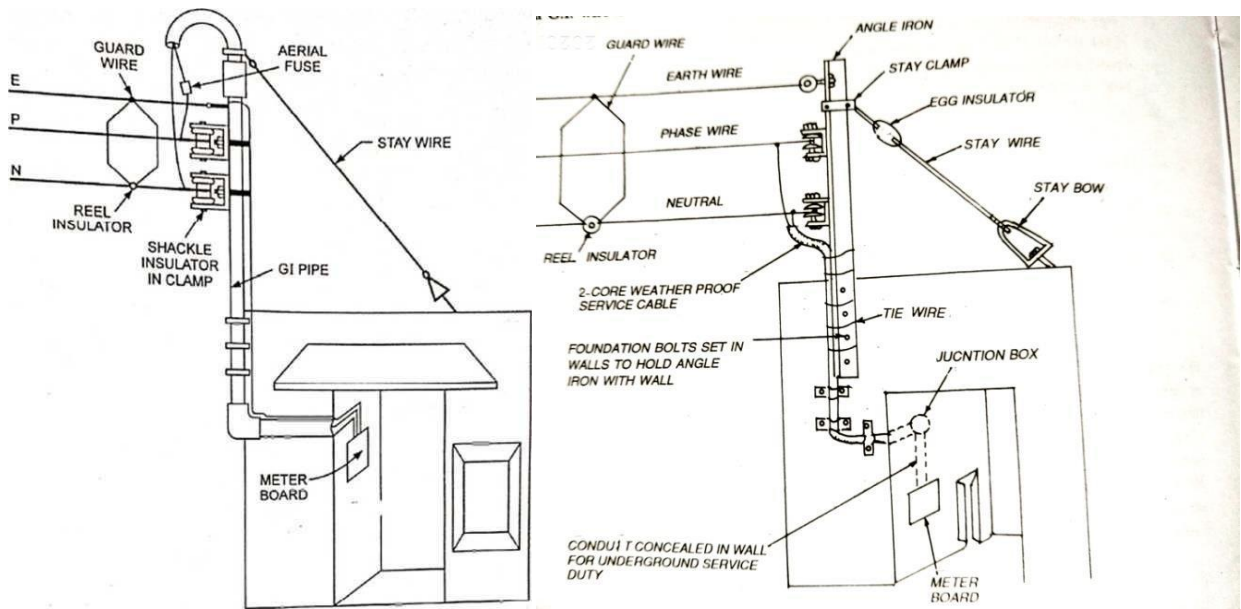

### c) Weatherproof cable method:

- In this method an 8 SWG G.I wire is stretched from the service pole to eye screw bolt fixed into a wall at a suitable height (in case of a double storey building) or to a GI pipe raised above the roof (in case of a single storeyed building).
- The weatherproof PVC cable is then brought to the building by clipping it to the GI wire stretched between service pole and building and then carried to service board usual i.e. on wooden batten or in GI pipe or in HG conduit.

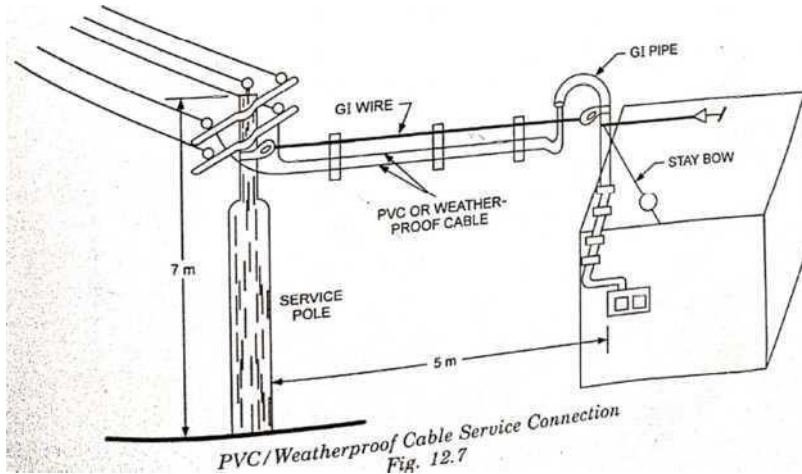

**d) Use of junction box or joint box :**

- For taking service connection from one house to another house use of junction or joint box is made.
- In this system the connection from existing pole are taken to junction box where the joints to cables for bifurcating the connections are made.

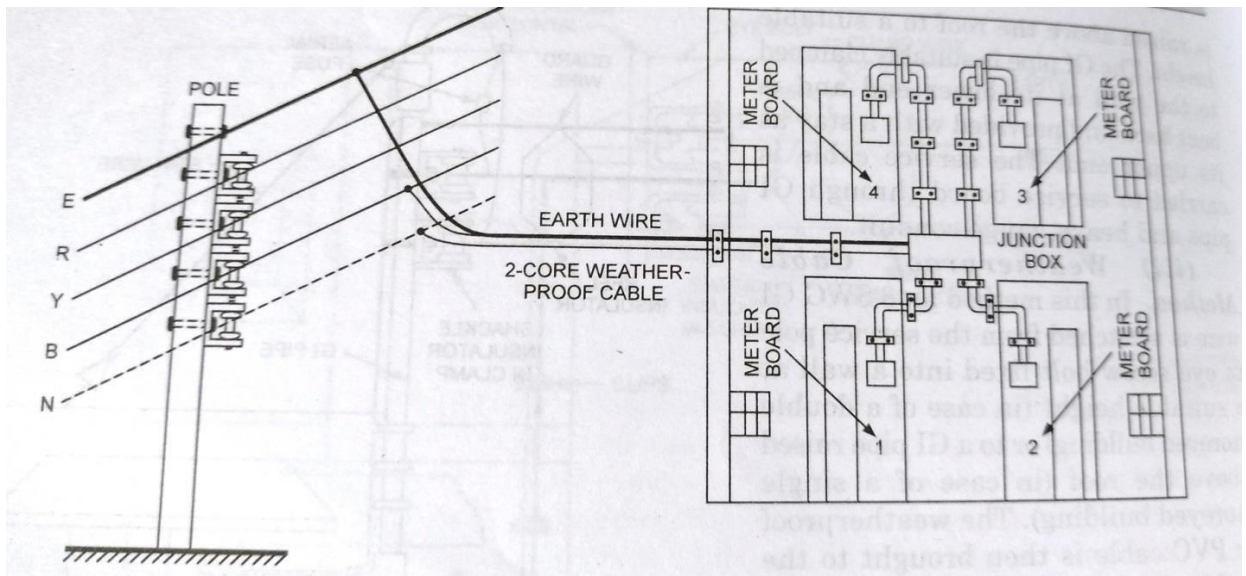



# SUBSTATIONS

- Electricity generated in power stations located far away from the consumers, is transmitted through long distance to the consumers .
- Therefore Substations serve as the sources of energy supply for the local areas of distribution in which these are located. i.e it is a medium of transferring power from generating unit to consumer .
- The main functions are to receive energy transmitted at high voltage from the generating stations, reduce the voltage to a value appropriate for local distribution and provide facilities for switching, frequency control, convert from ac to dc & vice versa etc.

## **TYPES OF SUBSTATIONS:**

Substations are of different types depending on

- (1) nature of duties
  - (2) service rendered
  - (3) operating voltage
  - (4) importance
  - (5) design
- For example frequency changing substation, power factor correction substation, converting substation, transformer substation, switching substation etc.

### **A. Classification on the basis of nature of duties:**

- 1.**Step-Up or Primary' Substations-** Such substations are usually located at generating stations. The generated voltage, which is usually low (**11 or 33 kV**), is stepped up to primary transmission voltage(132,220or 440kv) which can be transmitted over long distance.
- 2.**primary grid substation-** Such substations are usually located at suitable load centre, where primary transmission voltage is stepped down to secondary voltage(**66 or 33kv**), again this voltage is stepped down to primary distribution voltage(**11,6.6 or 3.3kv**) in secondary substation.
- 3.**step down or distribution substation-** Such substations are usually located at load centre where primary distribution voltage is stepped down to secondary distribution voltage(**415/240v**).

### **B. Classification on the basis of service rendered:**

1. Transformer Substations
2. Switching Substations
3. Converting Substations

### **C. Classification on the basis of operating voltage:**

1. High Voltage Substations (**HV Substations**)- involving voltages between **11 kv and 66 kV**.
- 2.Extra High Voltage Substations (**EHV Substations**)- involving voltages between **132 kV and 400 kV**.
- 3.Ultra High Voltage Substations (**UHV Substations**) -operating on voltage above **400 kV**.

### **D. Classification on the basis of importance:**

1. **Grid. Substations-** These are the substations from where bulk power is transmitted from one point to another point in the grid. any disturbance in these substations may cause the failure of the grid.

2. **town Substations-** These substations step-down the voltages at 33/11 kV for further distribution in the towns and any failure in such substations results in the failure of supply for whole of the town.

**E. Classification on the basis of design:**

1. **Indoor Type Substations-**

- In such substations the apparatus is installed within the substation building,
- such substation usually for a voltage up to 11KV but can be erected for the 33 kV and 66 kV when the surrounding atmosphere is contaminated with impurities such as metal corroding gases and fumes, conductive dust etc.
- Industrial units , important commercial complexes, railway stations ,telephone exchange, cinema house, continuous processing plant all employ such indoor substations
- The chamber space within which equipment of any one main bus-bar connection is mounted is called compartment or cell
- There are several compartment like control compartment, indicating and measuring compartment, protective device compartment, bus-bar compartment, circuit breaker compartment etc
- The substation building should be constructed providing the necessary accommodation for the transformer, HT and LT switchgear and cable trenches for incoming and outgoing cables.
- Adequate provision for ventilation must be ensured, so that there is free circulation of air on all sides of the transformer and within the building.

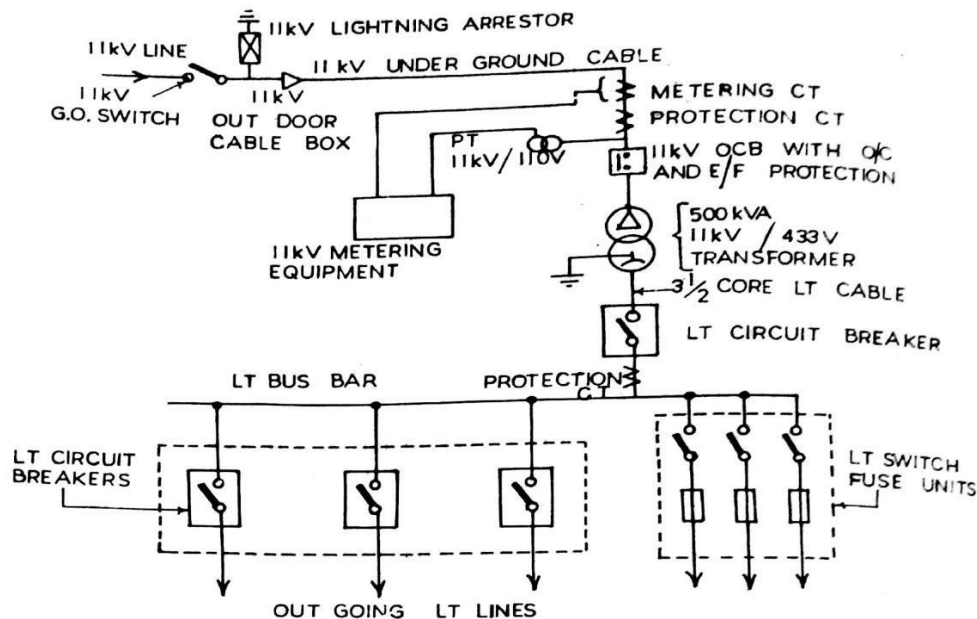

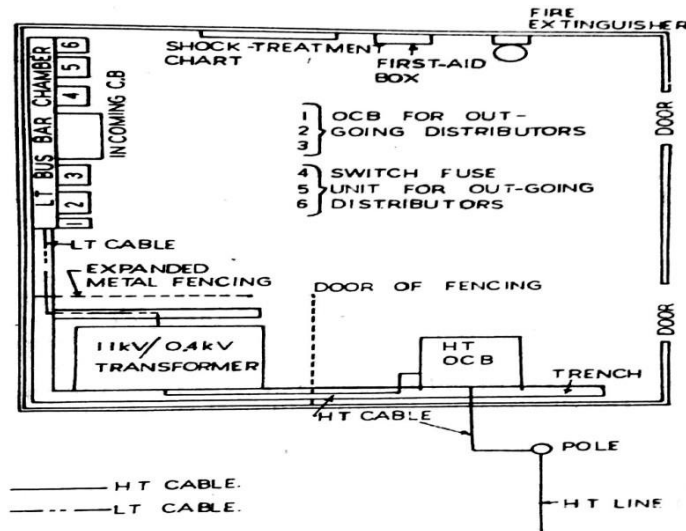

- The components of indoor substations are transformer, OCB, isolator, measuring instruments, busbar, storage battery, fire fighting equipment (such as fire extinguisher, fire bucket with water & sand), first aid chart, first aid box, danger plate, protective device, CT & PT etc.

2. **Outdoor Substations-** In such substations the apparatus is installed outside. These substations are further subdivided into 2 types

a) **pole mounted substation –**

- Such substations are erected for distribution of power in localities.
- Single stout pole or H-pole and 4-pole structures with suitable platforms are employed for transformers of capacity up to 25 kVA, 125 kVA and above 125 kVA (but up to 250 kVA) respectively.
- On an H-pole structure, the base channel 100 mm X 50 mm size, on which the transformer is to be mounted, is erected at a height of 2.44 m from ground level.
- With great care, the transformer is lifted up and placed on the base, and bolted after it has been hoisted properly.
- 11 kV lightning arrestors (3 in number) are erected at the top of the H-pole structure for the protection of the transformer against lightning.
- Earth terminals of all the three lightning arrestors are joined together and connected to earth.
- Gang operating (G.O.) switch installed below the line conductor taps the supply to transformer.
- The operating handle of G.O switch is located on one pole of structure at a height of 1.25m from ground.
- Horn gap fuse installed below G.O switch protect the transformer.
- On LT side of transformer a  $3\frac{1}{2}$  core LT cable is taken from LT bushing terminal to LT main switch with fuse.

- LT main switch connected to LT distribution switch from which LT cable are taken.
- Connecting jumpers from the 11 kV line to the G.O. switch, from the G.O. switch to the fuse unit, and from the fuse unit to transformer, bushing should be covered with empire tape or polythene pipe for safety
- Tinned CU fuse wire are used on both LT & HT side
- LT switches should be three-phase iron-clad with earthing terminals, of current carrying capacity matching the capacity of the transformer.
- Barbed wire should be wrapped on pole at the height of 2m above ground to prevent climbing
- A danger plate is provided on pole as warning.
- All metal fittings are painted with aluminium paint.
- 3 pits are provided with earth electrode .One of the two earth electrode on either side of D.P. structure is connected to the lightning arrestor and other is connected to the neutral of transformer on LT side, and third is connected to transformer body, to the handle of G.O switch & to the body of LT switch
- All 3 earth pits are interconnected.

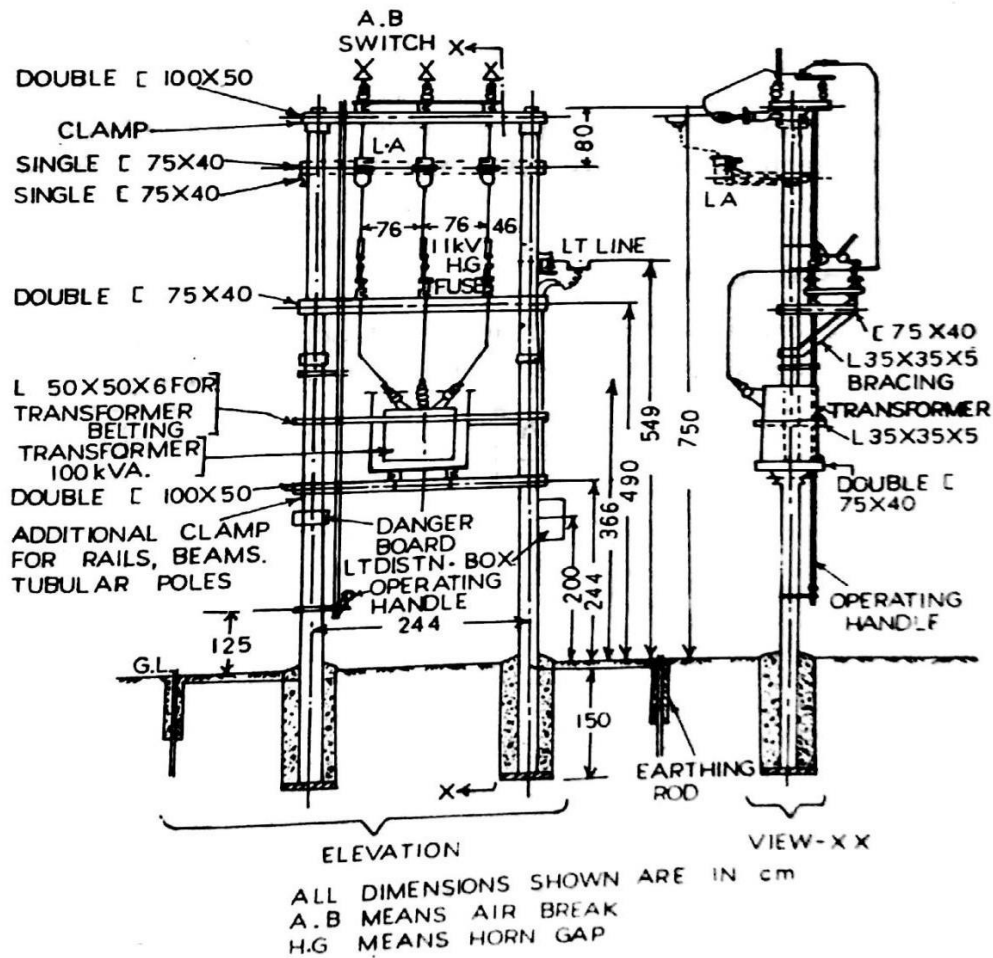

**b) plinth/foundation mounted substation-**

- For transformer of capacity above 250KVA and voltage for 33KV & above such substation is used.
- These substation are built entirely in open space.
- The component required & installation is similar to pole mounted substation, except that all heavy equipments are mounted in separate foundation for high rating of transformer.

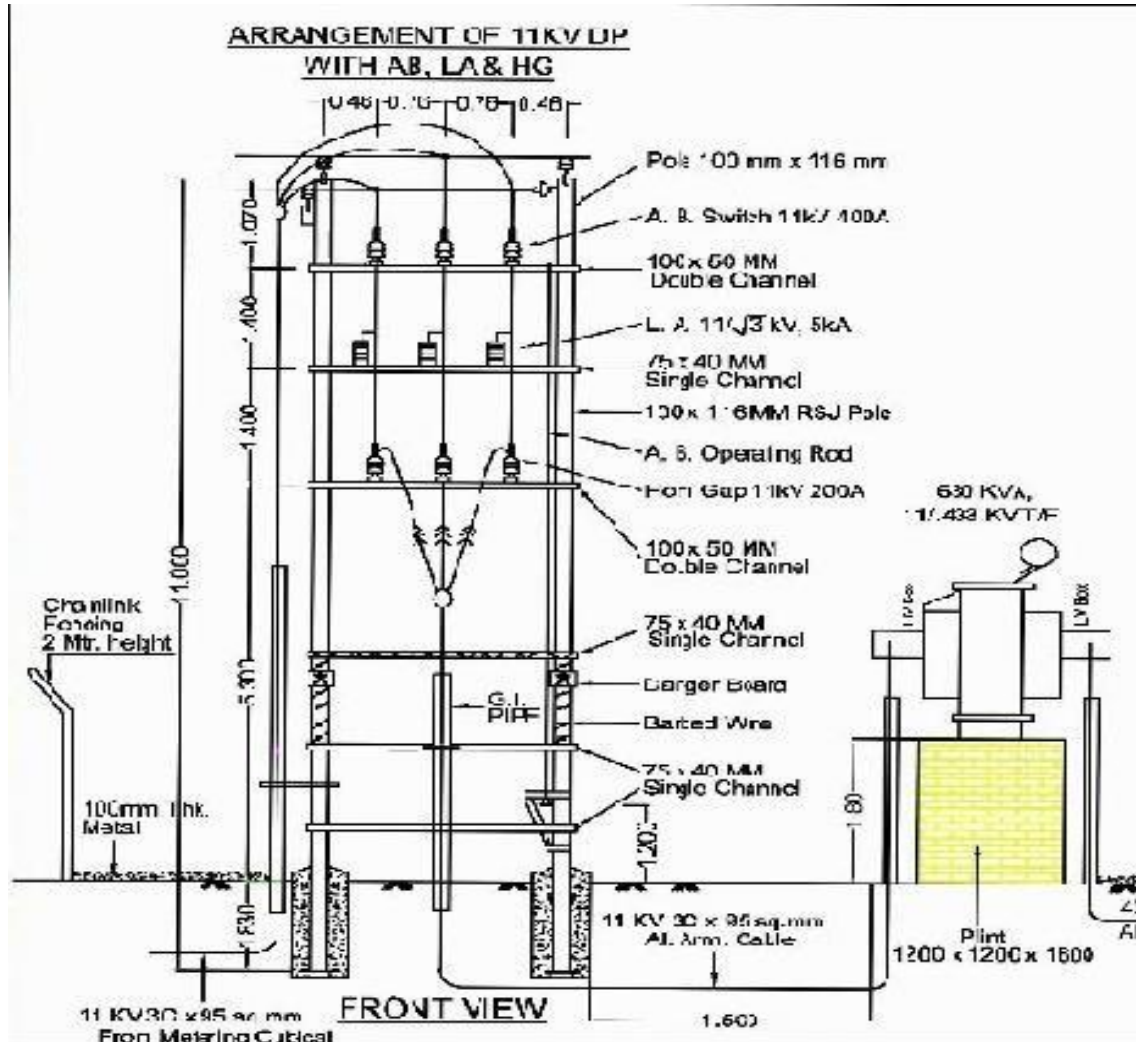

**Advantages and Disadvantages of Outdoor substation over indoor substation:**

**Advantages:-**

- All the equipment is within view and therefore fault location is easy.
- The extension of the installation is easier, if required .
- The time required in erection of such substations is lesser.
- The smaller amount of building materials (steel-concrete) is required.
- the construction work required is comparatively smaller & cost of switchgear installation is low.
- repairing work is easy

## Disadvantages

- (i) The various switching operations with the isolators, as well as supervision and maintenance of apparatus is to be performed in open air during all kinds of weather.
- (ii) More space is required for substation.
- (iii) Length of control cable required is more.
- (iv) Protection devices are required to be installed for protection against lightning surge
- (v) The influence of rapid fluctuation in ambient temperature and dust and dirt deposit upon the outdoor substation equipment makes it necessary to install apparatus specially designed for outdoor service & therefore more costly.

## Selection & location of site for a substation:

1. Types of substation
2. Availability of suitable and sufficient land
3. Communication facility
4. Atmospheric pollution
5. Availability of essential amenities to staff

## Equipment for substation and switchgear installation

### 1. BUSBAR:

- It is a main bar or conductor carrying current to which many connection may be made
- It may be copper, aluminium, steel, ACSR OR AAC.
- It may be rectangular, square or round in shape
- Rectangular shape may be preferred due to high rate of heat dissipation, greater cooling surface, skin effect reduce etc.
- Coating busbar with paint improve their rate of cooling, protect steel busbar from corrosion
- Now a days flexible busbar are mostly used, is supported by strain insulator.
- The most common sizes of bus-bars are 25 x 6 (150mm<sup>2</sup>) , 75x6(450 mm<sup>2</sup>); 100 x 6 (600 mm<sup>2</sup>); 125 x 6 (750 mm<sup>2</sup>);100 X 10 (1,000 mm<sup>2</sup>); 125 x 10 (1,250 mm<sup>2</sup>); 150 x 10 (1,500 mm),etc

### 2. REACTORS:

- A reactor is a coil having large inductive reactance in comparison to its ohmic resistance & is used to limit the short circuit current.

### 3. STATION INSULATOR:

- It is used to insulate & fix busbar system
- It is of 2 types i.e post insulator & bushing insulator.
- Post insulator consist of porcelain body, cast iron cap & flanged cast iron base. It is fixed by busbar clamp & available round, oval & square flanged base shape.
- A bushing or through insulator consists of porcelain-shell body, upper and lower locating washers and mounting flange with hole drilled for fixing bolt



- For current rating above 2000A, bushing are designed to allow main busbar

#### 4. SWITCHGEAR:

- The apparatus used for controlling, switching and protecting the electrical circuit and equipment is known as switchgear.
  - Two main parts of switchgear is switch & circuit breaker .
- A.B SWITCH:** Air Break switch has both blade and contact equipped with arcing horn. Arcing horns are pieces of metal between which the arc resulting from opening a circuit carrying current is allowed to form. As the switch opens, these horns are spread farther and farther apart and the arc is lengthened until it finally breaks.
  - ISOLATOR:** these are only used for isolating circuit. It operate under no load condition. These are provided on each side of circuit breaker to provide isolation.
  - OIL SWITCH:** The oil switch has both the blade and the contact mounted in a oil-filled tank. The switch is usually operated from a handle on the outside of the case. As the switch opens, the arc formed between the blade and contact is quenched by the oil. Oil switches may be remote-controlled as well as manually operated. These are used for capacitor switching, street lighting control and automatic disconnect in case of power failure.
  - EARTHING SWITCH:** it is connected between line conductor & earth. Normally it is open & it is closed to discharge the trapped voltage on isolated or disconnected line. Normally these are mounted on the frame of isolator.
  - FUSES-** it is a protective device which break the circuit under abnormal condition .High rupturing capacity (HRC) Fuse links provides complete protection to cables, switchgear. controlgear and other equipment by limiting the current, both in magnitude and in the time duration, that can pass through these devices in circuit.
  - CIRCUIT BREAKER:** it is a mechanical device , which make or break the circuit under normal or abnormal condition.
  - RELAYS:** The protective relay is an electrical device interposed between the main circuit and the circuit breaker in such a manner that any abnormality in the circuit act on the relay, which in turn, if the abnormality is of a dangerous character, causes the breaker to open and so to isolate the faulty element.
  - INSTRUMENT TRANSFORMER:** . AC type protective relays are actuated by current and voltage supplied by current and potential (or voltage) transformers, known as instrument transformers. The main function of instrument transformers are:
    - To provide insulation against the high voltage of the power circuit and to protect the apparatus and the operating personnels from contact with the high voltages of the power circuits.
    - To supply protective relays with current and voltage of magnitude proportional to those of the power circuit but sufficiently reduced in magnitude so that the relays can be made relatively small and inexpensive.
    - Possibility of different types of secondary connections to obtain the required currents and voltages.

- i) **POWER TRANSFORMER:** used for step up voltage at generating station & step down the voltage at distribution substation.
- j) **LIGHTNING ARRESTERS:** The lightning arrester is a surge diverter and is used for protection of power system against the high voltage surges It is connected between the line and earth and so diverts the incoming high voltage wave to the earth.
- k) **INDICATING & METERING INSTRUMENT:** Ammeters, voltmeters, wattmeter, kVARh meters, power factor meters, reactive-volt-ampere meters are installed in substation to control and maintain a watch over the currents flowing through the circuit & over the power load.
- l) **BATTERIES:** in power station relay, automatic control equipment, emergency lighting circuit are supplied by station batteries. Lead acid battery most commonly used in power station.

**CARRIER CURRENT EQUIPMENT:** Such equipment is installed in the substations for communication, relaying, telemetering or for supervisory control.

**CONTROL CABLE:** control cable and conduit system are required for affecting automatic control.

**SWITCH YARD:** switchyard houses transformers, circuit breakers and switches for connecting and disconnecting the transformers and circuit breakers

**1) A 37 kW connection is to be given to an agriculture field at 415 V, 3-phase, 50 Hz. The connection is to be given from a 3-phase, 11 kV overhead distribution line which is available at a distance of 40 meters. The motor has a full-load efficiency of 85% and power factor 0.8. Make a neat sketch showing how will you arrange the supply and estimate quantity or material required.**

Solution:

Given that consumer load= 37 KW(output power)

$$\text{As load efficiency}=85\% ,\text{input power}=\frac{\text{output power}}{\text{efficiency}}=\frac{37}{0.85}=43.52 \text{ KW}$$

$$\text{Input power in KVA}=\frac{\text{power in KW}}{p.f}=\frac{43.52}{0.8}=54.4$$

$$\text{Full load current on primary side of transformer } ,I_1=\frac{\text{input power in KVA}\times 1000}{\sqrt{3}\times V_1}=\frac{54.4\times 1000}{\sqrt{3}\times 11\times 1000}=3.30\text{A}$$

$$\text{Full load current on secondary side of transformer } ,I_2=\frac{\text{input power in KVA}\times 1000}{\sqrt{3}\times V_2}=\frac{54.4\times 1000}{\sqrt{3}\times 415}=87.64\text{A}$$

Thus the service connection is proposed to be provided by installing an outdoor pole mounted substation having 63 kVA, 11/0.415 kV , delta-star connected, 3-phase, 50 Hz transformer and Assume it will be mounted on a two pole structure 10meter from consumer premises. ACSR 6/1×2.11mm al conductor will be used to connect transformer to overhead line.

The service connection is proposed to be provided by a 3½core, 25 mm<sup>2</sup> (7/2.24 mm) al conductor armoured cable having current carrying capacity of 107 A.

The quantity of material is estimated as follows:

ESTIMATION TABLE

SI NO.	DESCRIPTION OF MATERIAL WITH SPECIFICATION	QUANTITY	
		QUANTITY	UNIT
1.	PCC poles 11 m long	2	nos
2.	Pressure channel 100×50×6mm MS channel,2.8m long	2(22)	Nos(kg)
3.	Transformer mounting channel 100×50×6mm MS channel,2.8m long	2(100)	Nos(kg)
4.	AB switch & HG fuse mounting channel 75×40×6mm MS channel,2.8m long	4(24)	Nos(kg)
5.	Angle for mounting LT distribution box50×50×6 MS channel,2.5m long	2(22)	Nos(kg)
6.	11 kV lightning arrestors,10KA	3	nos
7.	11 kV gang operating air break switch,3pole(200Amp)	1	set
8.	11 kV disc insulators	3	nos
9.	11 kV horn gap fuse unit,3pole(200Amp)	1	set
	ACSR 6/1×2.11mm al conductor	30	meter
10.	11 kV/415 V 63 kVA,50Hz distribution transformer	1	set
11.	Distribution box consisting of 1 no. 100 A main switch and 4 nos, outgoing switches	1	set
12.	Stay sets	2	set
13.	Stay wire 7/8 SWG	35	kg
14.	Stay insulator	2	nos
15.	Say clamp	2	nos
16.	Pipe Earthing sets	3	set
17.	No. 8 SWG GI wire for earthing	4	kg
18.	Barbed wire 12 x 12 SWG	18	kg
19.	Binding wire	1	kg
20.	Aluminium paint	2	litres
21.	Danger notice plate	1	nos
22.	Nuts and bolts of required sizes	10	kg
23.	Empire tape, thimble, jumper, other sundry item required to complete work		
24.	Concreting 1:4:8	2	nos
25.	3 <sub>2</sub> <sup>1</sup> core 25 sq.mm PVC insulated LT cable	20	meter
26.	LT cable box indoor type 3 <sub>2</sub> <sup>1</sup> core 25 sq.mm complete with all jointing material	1	Nos
27.	LT cable box outdoor type 3 <sub>2</sub> <sup>1</sup> core 25 sq.mm complete with all jointing material	1	Nos

28.	IC cutout fitted with fuse wire complete with sealing device	1	Nos
29.	Meter box sheet metal type locking arrangement ,painting etc 25 x 30 cm 45 x 60 cm	2  1 1	Set  Nos Nos
30.	Energy meter 3 phase,4 wire ,50Hz,100A,415V	35	kg
31.	Energy meter singlephase,50Hz,5A,250V	2	nos
32.	8 SWG GI wire	20	meter
33.	Nut & bolts	1	kg
34.	Concreting 1:4:8		