

ANALOG ELECTRONICS

&

OP-AMP

4th semester Electrical Engg.

Prepared by:

P. BHAWANI

LECTURER IN ELECTRONICS & TELECOMMUNICATION ENGG.

GOVERNMENT POLYTECHNIC BHUBANESWAR

1. PN JUNCTION DIODE

1.1 P-N Junction Diode

A PN junction diode is two-terminal semiconductor device, which allows the electric current in only one direction while blocks the electric current in opposite or reverse direction.

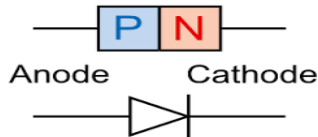

The 'P' side of a PN junction diode is always positive terminal and is called as anode. Other side which is negative is called as cathode.

1.2 Working of Diode

As diode is a two terminal device, the application of a voltage across its terminal leaves three possibilities

- i) No Bias ($V_D = 0V$)
- ii) Forward Bias ($V_D > 0V$)
- iii) Reverse Bias ($V_D < 0V$)

NO BIAS ($V_D = 0V$)

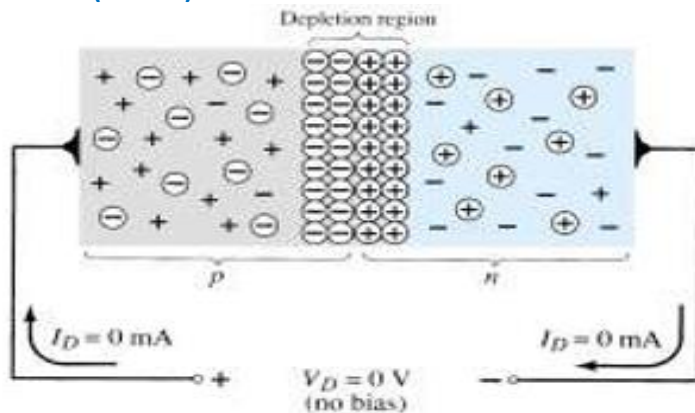

- In this case, no external voltage is applied to the PN junction diode.
- Due to concentration gradient, the holes from P region diffuse to the N region where they combine with the free electrons and the free electrons from the N region diffuse to the P region where they combine with the holes.
- The negative immobile acceptor ions in P region and positive donor ions in N region are left uncovered in the vicinity of junction.
- Now no further diffusion of holes and free electrons takes place across the junction because the holes trying to diffuse to N region are repelled by immobile positive ions and the electrons trying to diffuse in P region are repelled by immobile negative ions.
- The region contains immobile ions near the junction where charge carriers are depleted is called Depletion layer.

FORWARD BIAS ($V_D > 0V$)

- When diode is connected in forward bias condition, the negative terminal of the battery is connected to the N type material and positive terminal of the battery is connected to the P type material.

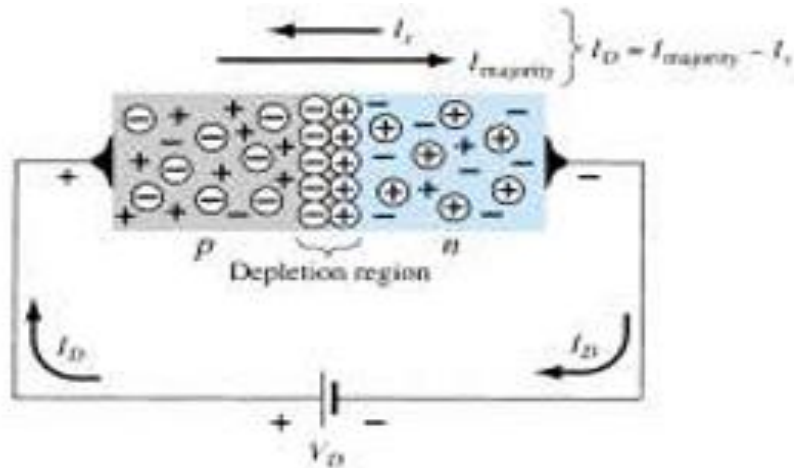

- If the external voltage becomes greater than the value of the potential; barrier approx. 0.7 volts for silicon and 0.3 volts for germanium, the potential barrier opposition will overcome and current will start to flow.
- This is because the negative voltage repels electrons towards the junction giving them the energy to cross over and combine with the holes being pushed in opposite direction towards the junction by the positive voltage.

REVERSE BIAS ($V_D < 0V$)

- In reverse bias condition, the negative terminal of the battery is connected to the P type material and positive terminal of the battery is connected to N type material.

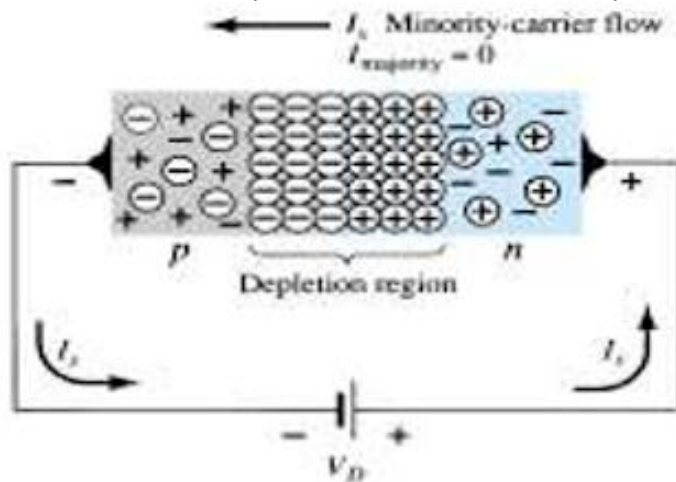

- The electrons of N type material attract towards the positive electrodes and move away from the junction, while the holes in the P type material are also attracted away from the junctions towards the negative electrodes.
- Due to which the depletion layer grows wider due to lack of electrons and holes. The result is that a high potential barrier is created thus preventing current flowing through the semiconductor material.

1.3 V-I characteristic of PN junction Diode.

The V-I characteristic of a diode is simply a curve or graph between the voltage applied across its terminal and the current that flows through it.

The entire graph can be divided into two parts namely

- Forward characteristic
- Reverse characteristic

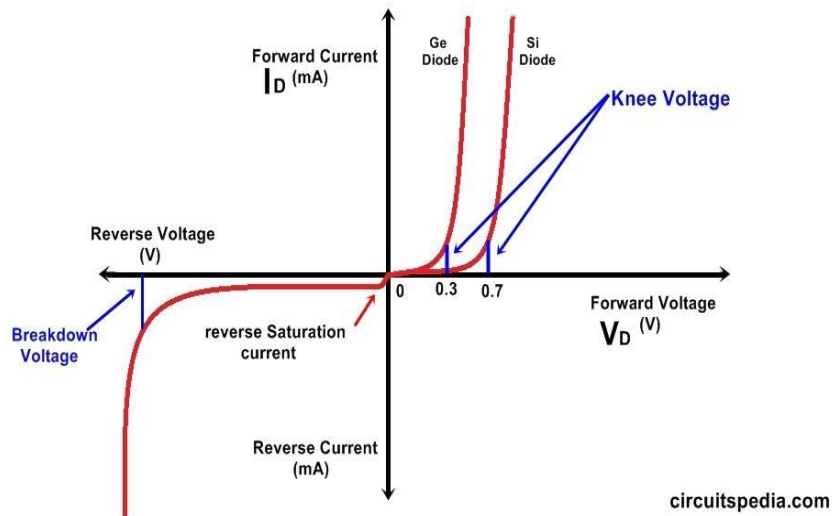

- **In forward characteristic**, the positive terminal of the battery is connected to the P type semiconductor and negative terminal of the battery is connected to the n type semiconductor. The diode is said to be in forward bias. In this graph V_F represents the forward voltage where as I_F represents the forward current.
- If the external voltage is less than barrier potential, diode allows only small amount of current which is considered as negligible.
- Once the applied voltage is slightly greater than the barrier potential, the diode current increases rapidly and diode conducts heavily.
- The voltage at which current start increasing is called Knee voltage. Its value is 0.7v for silicon and 0.3v for germanium.
- **In reverse characteristic**, the negative terminal of the battery is connected to the P type semiconductor and the positive terminal of the battery is connected to the N type semiconductor.
- The diode is said to be in reverse bias. Here V_R represents the reverse voltage whereas I_R represents the reverse current.
- When the applied reverse voltage is below the breakdown voltage, the diode current is small and remains constant.
- As the reverse voltage is increased to a sufficiently large value, the diode reverse current increases rapidly. The applied reverse voltage at which this occurs is called as Breakdown voltage of a diode.

1.4 DC load line

- DC load line is a graphical analysis which give precise relationship between forward voltage and forward current.
- Consider a simple diode connected in series with a load resistance R_L across a supply voltage V_s . Here the diode is forward biased.

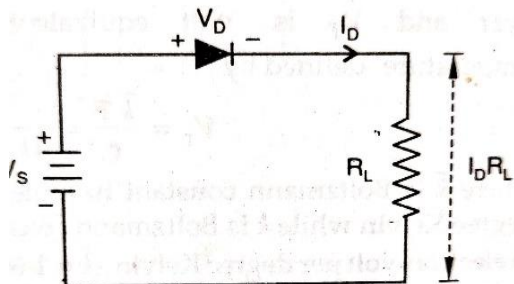

- Applying Kirchhoff's voltage law to the circuit, we have

$$V_S - V_D - I_D R_L = 0$$

Where I_D is forward diode current and V_D forward diode voltage

$$I_D = \frac{V_S}{R_L} - \frac{V_D}{R_L}$$

- This represents a straight line. So DC load line is a straight line.

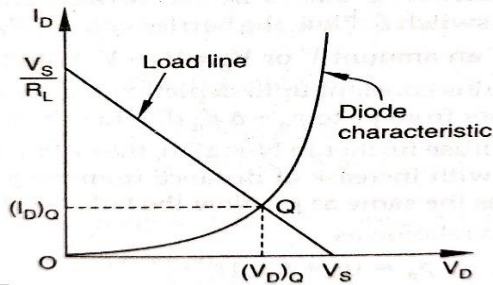

- From the above equation, when $V_D = 0$ then $I_D = \frac{V_S}{R_L}$ and when $I_D = 0$ then $V_S = V_D$.
- A line passing through the points $\frac{V_S}{R_L}$ and V_S is called a load line.
- The intersection of forward characteristic and DC load line of the diode is called Operating point or Quiescent point or Q point of the device.

1.5 Important terms such as Ideal Diode, Knee voltage

An **ideal diode** is a two terminal device which has

- perfect conductor with zero resistance when forward biased.
- perfect insulator with infinite resistance when reverse biased.

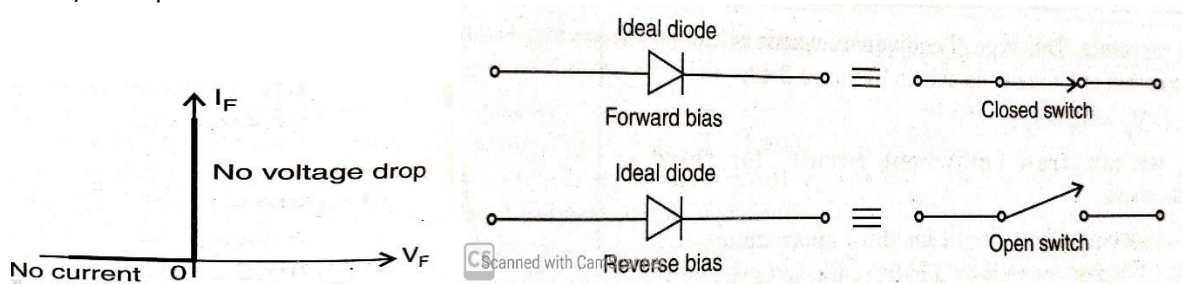

The ideal diode acts like an automatic switch. The switch is closed when the diode is forward biased and is open when it is reverse biased.

KNEE VOLTAGE

- The forward voltage at which the current through the junction starts increasing rapidly is called Knee voltage. Knee voltage is also called as Cut in voltage or threshold voltage.
- The knee voltage for silicon is 0.7 volt whereas for germanium it is 0.3 volt.

APPLICATION:

- ✓ Rectifier circuit
- ✓ Clipping and clamping circuit
- ✓ Voltage multiplier
- ✓ AM detector

1.6 Junctions break down.

1.6.1 Zener breakdown 1.6.2 Avalanche breakdown

- The reverse voltage at which PN junction breaks down with sudden rise in reverse current.
- The breakdown voltage depends upon the width of the depletion region.

The following two processes cause junction breakdown due to the increase in reverse voltage.

- Zener breakdown
- Avalanche breakdown

ZENER BREAKDOWN

- The zener breakdown takes place in junction which are heavily doped.
- When breakdown voltage is applied, a very strong electric field appears across narrow depletion layer which breaks the covalent bonds. Now electrons-holes pairs are generated.
- A small further increase in reverse voltage causes sharp increase the reverse current.

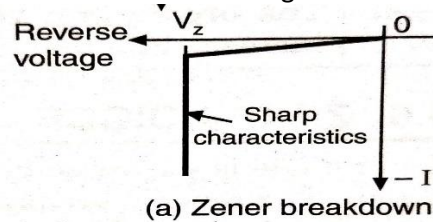

AVALANCHE BREAKDOWN

- The avalanche breakdown occurs in junction which are lightly doped.
- As the reverse voltage increase, minority carriers are accelerated due to which kinetic energy is increases.
- While travelling, these carriers collide with stationary atoms within the crystal structure. Due to this covalent bonds break and generate additional carriers.

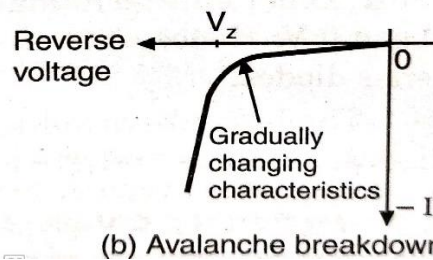

- These additional carriers pick up energy from the applied voltage and generate more carriers. As a result of this, the reverse current increases rapidly.
- This cumulative process of carrier generation (or multiplication) is known as Avalanche breakdown.

1.7 P-N Diode clipping Circuit.

- The circuit with which the waveform is shaped by removing (or clipping) a portion of the applied wave without disturbing the remaining part of the input signal is known as Clipping circuit.
- The basic components required for a clipping circuits are an ideal diode and a resistor.

The clipping circuits are of the following types

- Positive clipper
- Negative clipper
- Biased clipper
- Combination clipper

Positive Clipper

- In a positive clipper, the positive half cycles of the input voltage will be removed.
- The diode is kept in series with the load. This is called positive series clipper circuit.

Positive Series Clipper and Positive Shunt Clipper

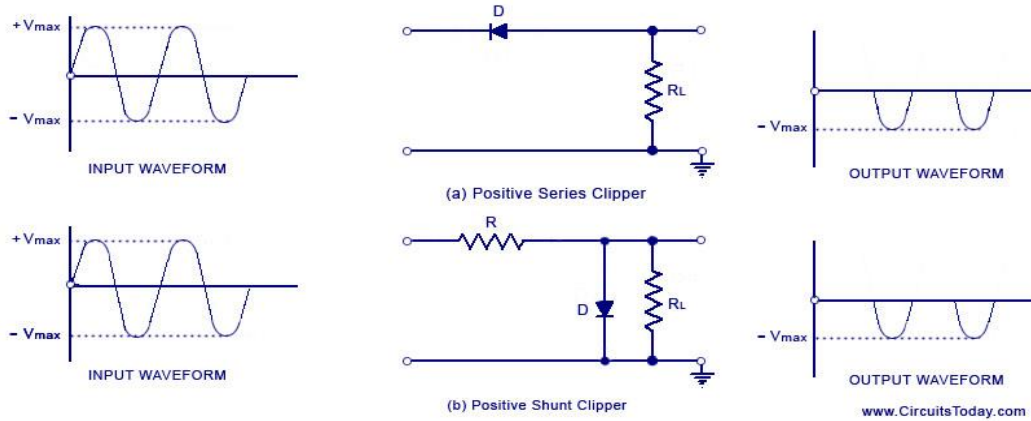

- During the **positive half cycle** of the input waveform, the diode D is reverse biased which maintains the output voltage at 0 volts. This causes the positive half cycle to be clipped off.
- During the **negative half cycle** of the input, the diode is forward biased so the negative half cycle appears across the output.
- In case of positive shunt clipper circuit, the diode is kept in parallel with the load. In this circuit the diode acts as closed switch when the input voltage is positive and as an open switch when the input voltage is negative the output waveform is the same as that of a series positive clipper circuit.

Negative Clipper

- In a negative clipper, the negative half cycle of the input signal will be removed.
- The diode is kept in series with the load. This is called negative series clipper circuit.

Negative Series Clipper and Negative Shunt Clipper

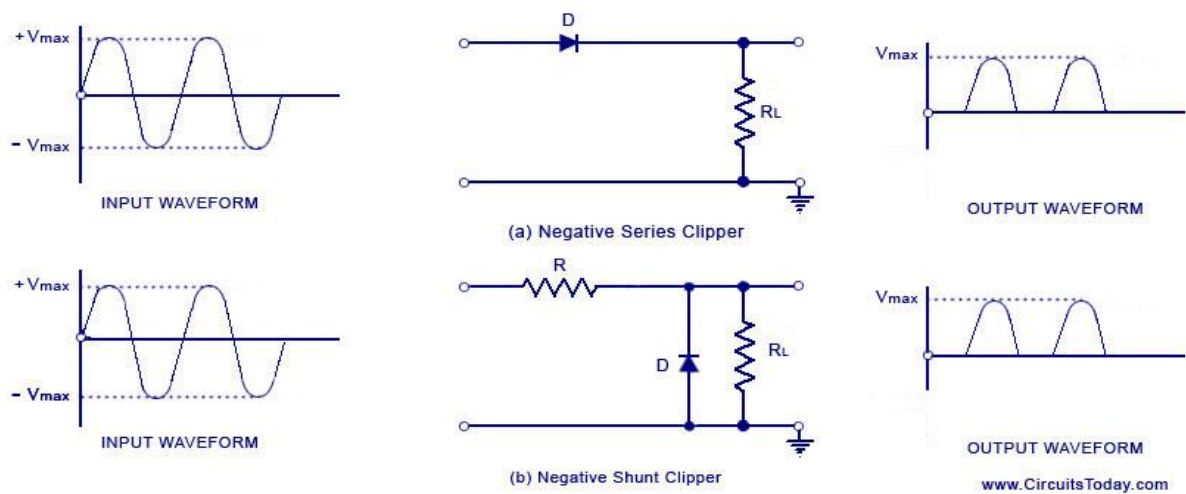

- During the positive half cycle of the input signal the diode D is forward biased and act as a closed switch. As a result, all the input voltage appears across the resistor.

- During the negative half cycle of the input voltage, the diode D is reverse biased, which maintains the output voltage at 0 volt. This causes the negative half cycle to be clipped off.
- In case of negative shunt clipper circuit, the diode is kept in parallel with the load. In this circuit, the diode acts as a closed switch for a negative input voltage and as open switch for a positive input voltage. The output waveform of the circuit is the same as that of series negative clipper.

Applications

- ✓ Used in FM transmitter to reduce noise.
- ✓ Used in Changing the shape of a wave
- ✓ Used to limit the voltage input to a device
- ✓ Used in Circuit transient protection
- ✓ Used in television circuit

1.8 P-N Diode clamping Circuit

- A clamper circuit can be defined as the circuit that shift the waveform to a desired DC level without changing the actual appearance of the applied signal.
- It comprises a capacitor, a resistor, an inductor and a dc battery if required.

Basically clamping circuits are of three types

- Positive clamper
- Negative clamper
- Biased clamper

Positive Clamper

- Positive clamper is a circuit which clamps the input signal waveform positively.

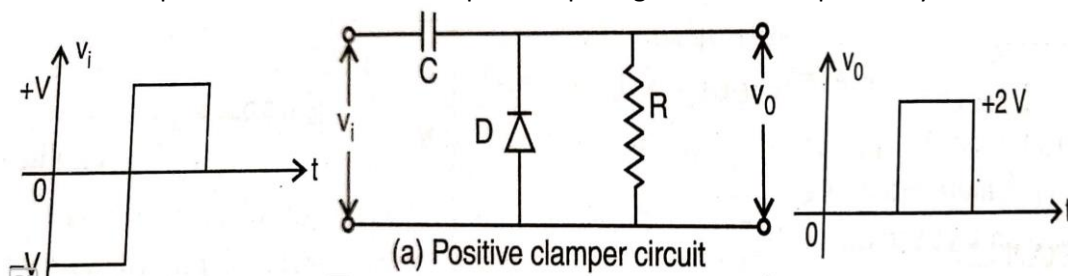

- The value of C & R_L so selected that the discharging time constant $\tau = C \cdot R_L$ is very large. This means that voltage across the capacitor will not discharge significantly during the interval when the diode is non-conducting.
- The discharging time constant is also made much larger than the time period T of the input signal.
- The charging time constant is quite small as compared to discharging time constant.
- During the negative half cycle of the input signal the diode is forward biased and behave as a short circuit. Since the charging time constant is quite small, the capacitor is charged to V volts very quickly. During this period, output voltage $V_o = 0$.
- During positive half cycle, the diode is reverse biased and act as an open circuit. As the discharging time constant (RC) is very large, the capacitor remains almost fully charged to V volt during the off time of diode.

Applying Kirchhoff's voltage law to the circuit, we have

$$V_i + V_c - V_o = 0$$

$$V_o = V_i + V_c = V + V = 2V$$

From the input and output waveform it can be observed that the output has been positively clamped.

Negative Clamper

- Negative clamper is a circuit which clamps the input signal waveform negatively.

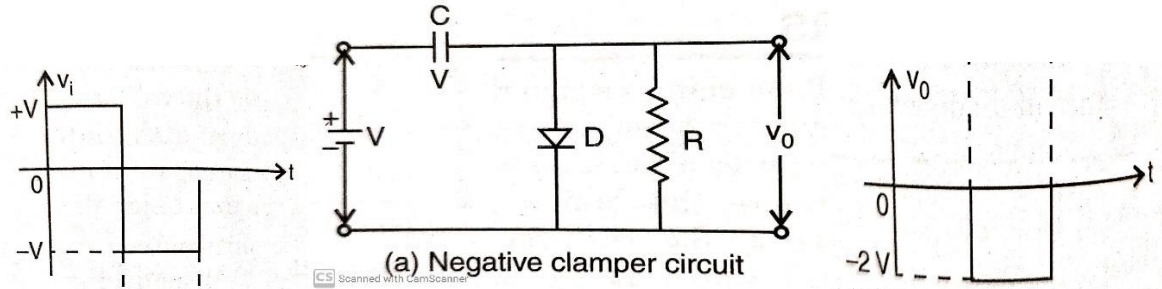

- During the positive half cycle of the input signal, the diode is forward biased and so acts as a short circuit. The capacitor charges to V volts very soon because the charging time constant is very small. The output is obtained across the short circuit diode. Hence $V_o = 0$
- During the negative half cycle, the diode is reverse biased and acts as an open circuit. Because the discharging time constant is much greater than the time period of the input signal, the capacitor remains almost fully charged to V volts during the OFF time of the diode.
- Applying Kirchhoff's voltage law to the circuit

$$-V_i - V_c - V_o = 0$$

$$V_o = -(V_i + V_c)$$

As $V_i = V_c = V$

So $V_o = -2V$

From input and output voltage waveform, it may be observed that output is negatively clamped signal.

Applications

- ✓ Used as test equipment
- ✓ Used for protection of amplifier
- ✓ Used to remove distortions
- ✓ Used as voltage amplifier

2. SPECIAL SEMICONDUCTOR DEVICES

2.1 Thermistors, Sensors & barretters

THERMISTORS

- A **thermistor** is a resistor whose value of the resistance alters with the change of the temperature.
- The word thermistor is a combination of thermal and resistor that means thermally sensitive resistor.

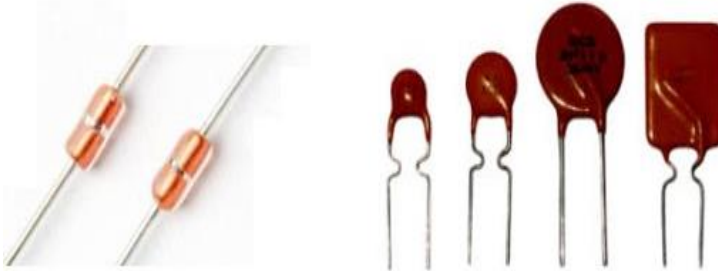

- The electrical characteristic of thermistor is a function of its temperature. It depends on both the ambient (surrounding) temperature and on internal power dissipation.
- In electrical circuits, the thermistors are used to stop the inrush current from the circuitries, as they are also sensors with the variation of the resistance they indicate about current.
- There are the 2 main categories of the thermistors first one is the NTC (negative temperature coefficient) and second is PTC (positive temperature coefficient).
- Negative temperature coefficient thermistor is such resistor whose resistance value falls with the increment of the temperature.
- NTC (Negative temperature coefficient) thermistors are mostly used for the resistance computations and to limit the value of the current in different circuitries.
- The positive temperature coefficients are such thermistors whose resistance value increases with the increment in the temperature.
- The PTC used in circuitries to provide protection against the overcurrent in the circuitries.
- Thermistors are made of mixtures of metallic oxide such as manganese, nickel, cobalt, copper, iron and uranium.
- They are made in the shape of Rod, Bead and Disc.
- Resistance values of thermistor are available from 100 ohms to over 10 mega ohms at room temperature depending upon type.

CHARACTERISTIC OF THERMISTOR

- In NTC, resistance decreases with an increase in temperature. The resistance falls exponentially as the temperature is increased.
- In PTC, resistance increase with an increase in temperature. The characteristic graph is linear in nature.

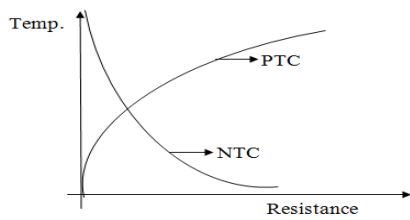

APPLICATION

- ✓ For measurement & control of temperature as in Ovens.
- ✓ They are used as sensing elements in microwave power measuring equipment.
- ✓ For regulating AC voltage.
- ✓ As temperature sensor for electronic thermometry.

SENSISTOR

- It is a heavily doped bulk semiconductor which has positive temperature coefficient of resistance i.e. the resistance increases as temperature increases.
- When the temperature of a sensistor is increased, the mobility of charge carriers is decreased and hence the resistivity is increased.
- A typical sensistor has temperature coefficient of resistance of 0.7 % per degree C over the temperature range of -60 to +150^o C.

APPLICATION

- ✓ They are used as thermal relay.
- ✓ They are used as temperature sensor for electronic thermometry.

BARRETTTER

- Barretter have a positive temperature coefficient i.e. the resistance increases as temperature increases.
- It operates at high temperature. Hence not suitable to use at ambient temperature.

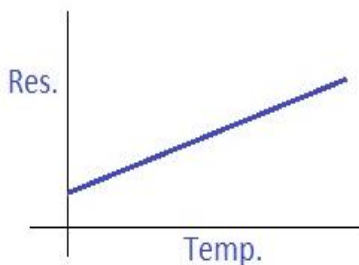

- It is formed by appropriately mounted piece of Wollaston platinum wire having diameter approximately 1.25 μm.
- It is capable of yielding power information over the range of 10⁻⁶ mw to 20 mw.

2.2 Zener Diode

ZENER DIODE

- Zener diode is a reversed biased heavily doped PN junction diode which is operated in the breakdown region.
- Due to higher temperature and current capability, Silicon is preferred in comparison to Germanium.

- When a zener diode is forward biased its characteristic are just as those of ordinary diode.
- As the reverse voltage applied to PN junction is increased, a value is reached at which the current increases greatly from its normal cut off value. This voltage is called Zener voltage(V_Z) or breakdown voltage. So when a zener diode is reversed biased it has sharp breakdown.
- The regulating ability of zener diode is an important feature that it maintains a constant voltage across its terminals over a specified range of zener current values.

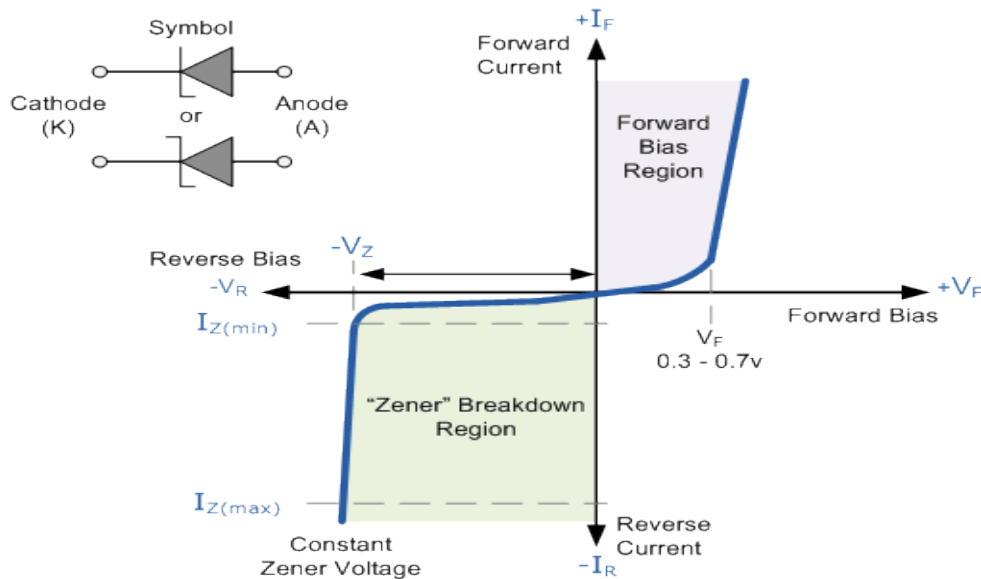

APPLICATION

- ✓ Voltage regulator
- ✓ Meter protection
- ✓ As a reference element
- ✓ Switching operation

2.3 Tunnel Diode

TUNNEL DIODE

- Tunnel diode is a high conductivity two terminal PN junction diode doped heavily about 1000 times higher than conventional junction diode. It is also known as **Esaki Diode**.

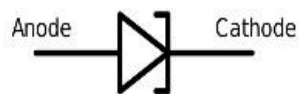

Symbol:

- As the concentration of impurity atoms is greatly increased in a PN junction then the depletion layer width reduces and the device characteristics are completely changed.
- Under such condition, the charge carriers will penetrate through the junction at the speed of light, even though they do not have enough energy to overcome the potential barrier.
- As a result of this, a large forward current is produced even if the applied forward voltage is much less than 0.3 V.

- The phenomenon of penetrating the charge carriers directly through the potential barrier instead of climbing over it is called Tunneling. That is why it is called Tunnel diode.
- These diodes are usually made of Germanium (Ge) or Gallium Arsenide (GaAs).

WORKING PRINCIPLE

Unbiased Tunnel diode:

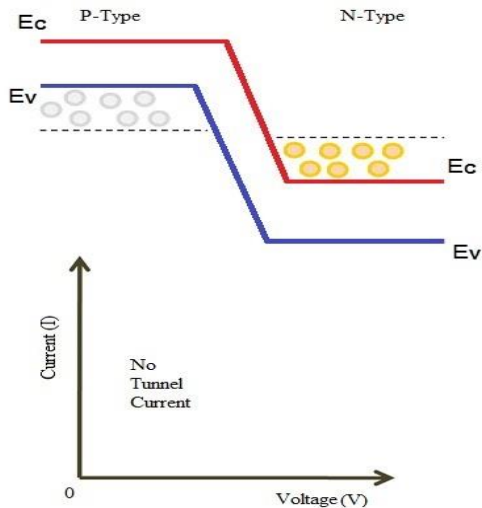

- In an unbiased tunnel diode, no voltage will be applied to the tunnel diode. Here due to heavy doping conduction band of N-type semiconductor overlaps with valence band of P-type material.
- Electrons from N side and holes from P side overlap with each other and they will be at same energy level.
- When temperature increases, some electrons tunnel from the conduction band of N region to the valence band of P region. Similarly, holes will move from valence band of P region to the conduction band of N region.
- Finally, the net current will be zero since equal numbers of electrons and holes flows in opposite direction.

Small voltage applied to the Tunnel diode

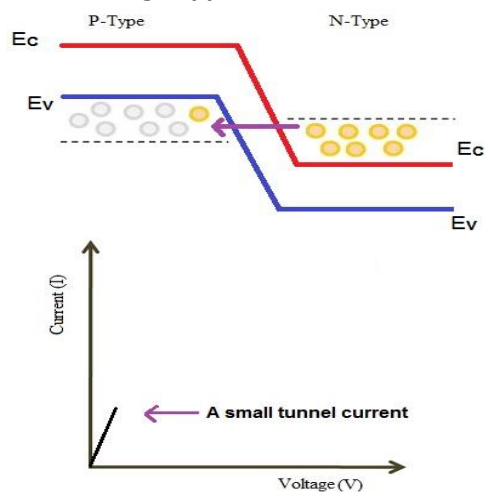

- When a small voltage, that has lesser value than the built in voltage (barrier potential) of the depletion layer is applied to the tunnel diode, there is no flow of forward current through the junction.
- Nevertheless, minimal number of electrons from conduction band of N region will start tunneling to valance band in P region.
- Therefore, this movement creates a small forward biased tunnel current.

Increased voltage applied to the Tunnel diode

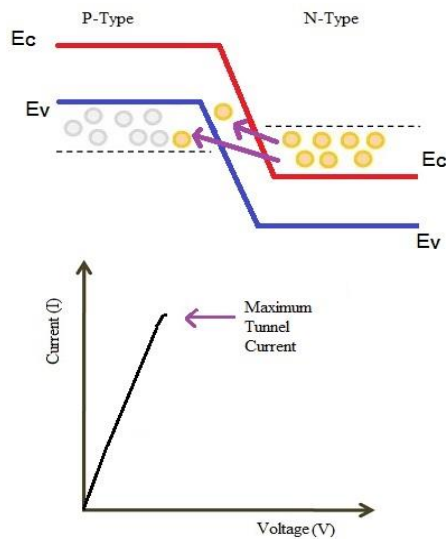

- When the amount of voltage applied is increased, overlapping between the bands are also increased.
- Maximum tunnel current flows when the energy level of N side conduction band and the energy level of P side valance band becomes equal.

Further increased voltage applied to the Tunnel diode

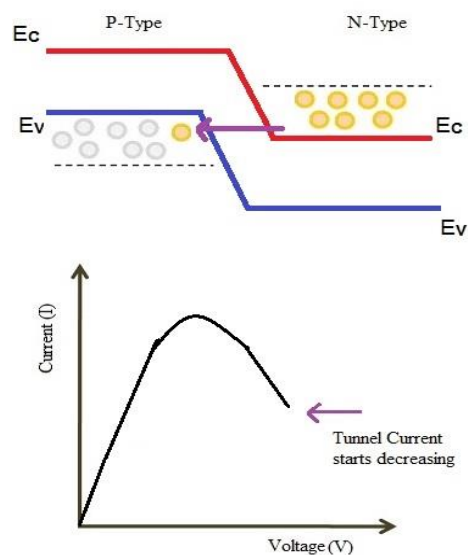

- A further increase in applied voltage will cause misalignment of the conduction band and valance band.
- Still there will be an overlap between conduction band and valance band.

- The electrons move from conduction band to valence band of P region. Therefore, this causes small current to flow. Hence tunnel current starts decreasing.
- Here current decreases when the voltage increases and this is the negative resistance of Tunnel diode

Largely increased voltage applied to the Tunnel diode

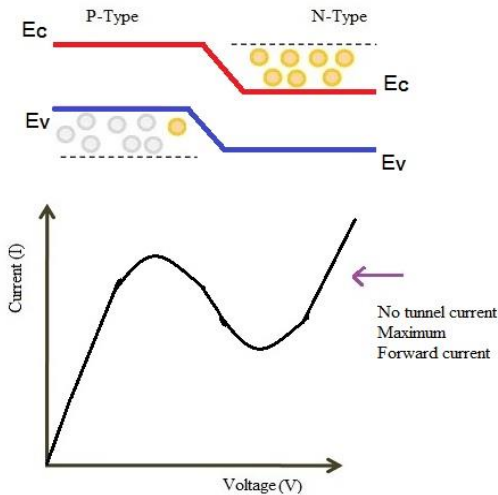

The tunneling current will be zero when applied voltage is increased more to the maximum. At this voltage level, the valence band and conduction band does not overlap. This makes tunnel diode to operate same as a PN junction diode.

V-I CHARACTERISTIC OF TUNNEL DIODE

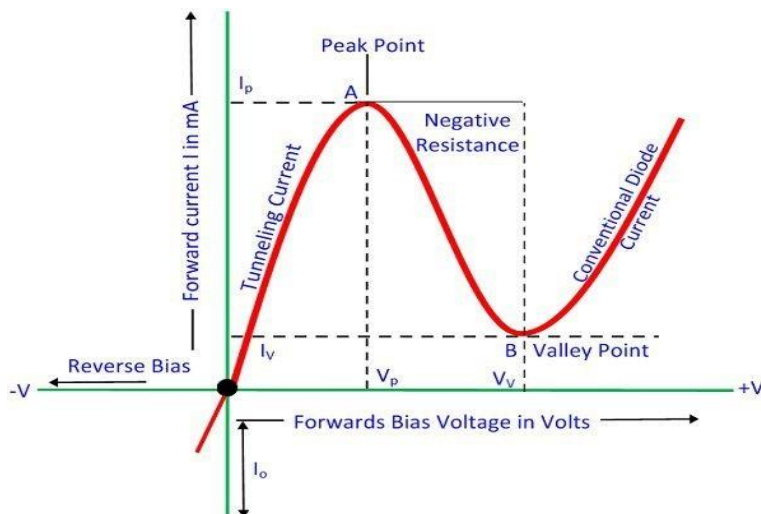

- As the applied forward voltage is increased from zero, the current increases very rapidly, till it reaches its maximum value known as peak current and the corresponding voltage is known as Peak voltage.
- If the forward voltage is further increased, the current decreases till it reaches its minimum value known as Valley current. In this region tunnel diode possess a negative resistance.
- As the voltage is further increased, the current increases in a usual manner as in a normal PN junction diode.

- If the Tunnel diode is reversed biased, the reverse current increases with the increase in reverse voltage.

APPLICATIONS OF TUNNEL DIODE

- ✓ Microwave oscillator
- ✓ Ultra high speed switching device
- ✓ Logic memory storage device
- ✓ Relaxation oscillator

2. 4 PIN Diode

PIN DIODE

- A PIN diode is a special type of diode that contains an undoped intrinsic semiconductor between heavily doped P type and N type semiconductor regions.

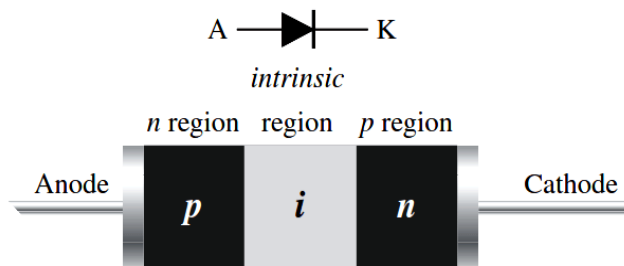

- The intrinsic region offers high resistance to the current flowing through it.
- When PIN diode is unbiased, there is a diffusion of electrons and holes across the junction due to the different concentration of atoms in the P, I, and N regions.
- The diffusion of electrons and holes produce a depletion layer across the PI and IN junctions.
- The depletion layers penetrate to a little distance in the P type and N type semiconductor regions but to a larger distance in the I region. Under such condition the device has a high value of resistance.

WORKING PRINCIPLE

- When the PIN diode is forward biased, the width of depletion layer decreases. As a result of this more carriers are injected into the I region. This reduces the resistance of the I region. Thus when a PIN diode is forward biased, it acts like a variable resistance. The forward resistance of an intrinsic region decreases with increasing current.
- When the PIN diode is reverse biased, the depletion layers becomes thicker. As the reverse bias is increased the thickness of the depletion layer increases till the I region becomes free of mobile carriers. The reverse bias at which this happens is called Swept out voltage. At this stage, the PIN diode acts like a constant capacitance.

APPLICATIONS

- ✓ It can be used as attenuator
- ✓ It can be used as constant impedance device
- ✓ It can be used as phase shifter
- ✓ It can be used as T-R switch in Radar applications.

3. RECTIFIER CIRCUITS & FILTERS

3.1 Classification of rectifiers

Rectifier

A rectifier is a circuit which use one or more diodes to converts ac voltage into pulsating dc voltage.

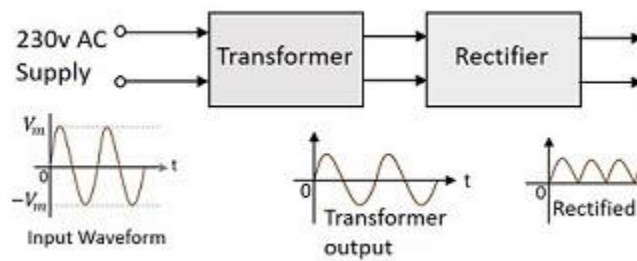

Classification

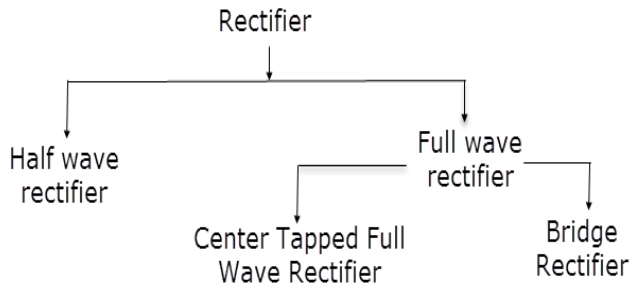

Half Wave Rectifier

- A half wave rectifier is one which converts ac voltage into a pulsating dc voltage using only one half cycle of the applied ac voltage.

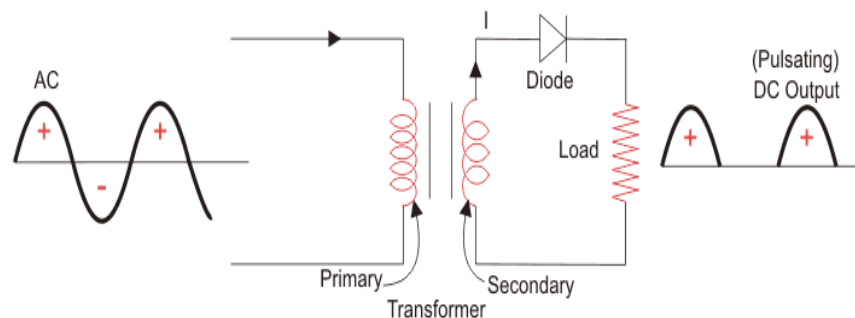

- The ac voltage to be rectified is applied to a single diode connected in series with a load resistor R_L .
- When it is required to step up or step down the input voltage, a power transformer is used.

Working Principle:

- During positive half cycle of input ac voltage, the diode D is forward biased and hence it conducts. Now a current flow in the circuit and there is a voltage drop across R_L . The voltage produced across the load resistor has the same shape as that of the positive input half cycle of the ac voltage.
- During negative half cycle, the diode D is reversed biased and hence it does not conduct. Now no current flows in the circuit i.e. $i_D=0$ & $V_0=0$.
- The net result is that only the positive half cycle of the ac input voltage appear across R_L . It means that only the positive half cycle of the ac input voltage is utilized for delivering AC power.
- As the circuit uses only half cycle of the ac input voltage, therefore it is popularly known as Half wave rectifier.

Advantages of half wave rectifier

- Easy to construct
- Few components to construct the half wave rectifier. So the cost is very low.

Drawback of Half Wave Rectifier

- The ripple factor is quite high. The output contains lots of varying components.
- The rectification efficiency is 40%. This indicates that half wave rectifier circuit is quite inefficient.
- The circuit has low transformer utilization factor that means transformer is not fully utilized.

Full wave Rectifier

Full wave rectifier is that type of rectifier which utilizes both the half cycle of AC input voltage. Hence in a full wave rectifier a unidirectional current flows through the load during the entire cycle of the input voltage.

There are two types of full wave rectifier

- Center tap full wave rectifier
- Bridge type full wave rectifier

Center Tap Full Wave Rectifier

- In center tapped full wave rectifier, the rectification is done by the usage of center tapped transformer.
- The circuit uses two diodes, which are connected to the center tapped secondary winding of the transformer.
- The input signal is applied to the primary winding of the transformer.

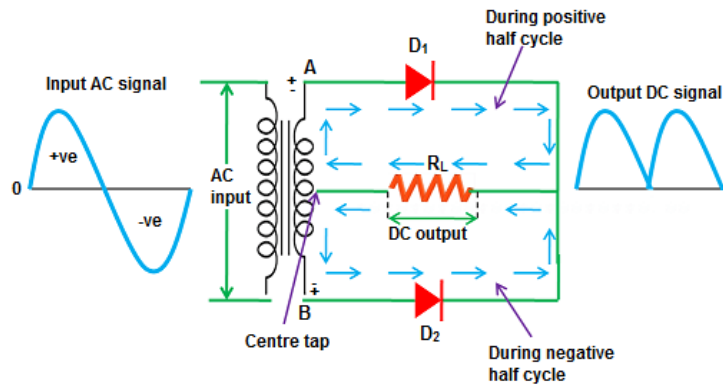

- The center-tap on the secondary winding of a transformer is usually taken as the ground or zero voltage reference point.
- The voltage between the center-tap and either end of the secondary winding is half of the secondary voltage.

Working Principle:

- During positive half cycle of the input voltage, the diode D_1 is forward biased and the diode D_2 is reverse biased. Hence diode D_1 conducts and diode D_2 is cut off for positive cycle.
- A current I_L flows through the load resistor R_L producing an output voltage V_0 .
- The direction of the current I_L and polarity of the output voltage V_0 developed across the load resistor R_L shown in the figure.
- During negative half cycle of the input voltage the diode D_1 is reverse biased and the diode D_2 is forward biased. Hence diode D_1 is cut off and D_2 conducts for negative cycle.
- Thus a current I_L flows through the load resistor R_L in the direction shown in figure.
- This current I_L produces an output voltage V_0 across the load resistor R_L .
- It is clear from above that for positive half cycle one diode conducts and for negative half cycle another diode conducts.
- Hence a unidirectional current flows continuously in a full wave rectifier.

Advantages

- The DC output voltage and load current values are twice than those of half wave rectifier.
- The ripple factor is much less than that of half wave rectifier.
- The efficiency is twice that of half wave rectifier.

Disadvantages

- The output voltage is half of the secondary voltage.
- The peak inverse voltage is twice that of the diode used in half wave rectifier.
- It is expensive to manufacture a center tapped transformer which produces equal voltages on each half of the secondary winding.

Bridge Type Full Wave Rectifier

- It is a circuit which converts alternating current into pulsating direct current using the diodes arranged in a bridge circuit configuration.
- It uses four diodes connected across the main supply.

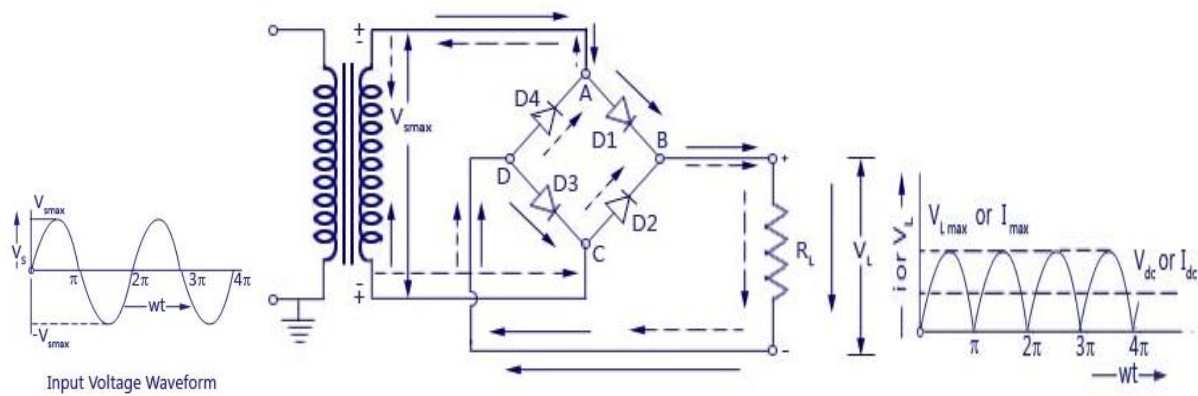

Working Principle:

- During positive half cycle, diode D_1 and diode D_3 are forward biased i.e. they conduct whereas diode D_2 and diode D_4 are reverse biased i.e. they do not conduct. Therefore, the current flow in arrow direction shown in figure. The output voltage V_0 is developed across the load resistor R_L .
- During negative half cycle, diode D_1 and diode D_3 are reverse biased i.e. they do not conduct whereas diode D_2 and diode D_4 are forward biased i.e. they conduct. The current flow direction shown in figure. The output voltage V_0 is developed across the load resistor R_L .
- The polarity of output voltage is same as that of positive half cycle. Hence a unidirectional current flows continuously in full wave rectifier.

Advantages

- No center tap is required on transformer.
- The peak inverse voltage across each diode is half of the center tap circuit of the diode.
- The transformer is less costly as it is required to provide only half the voltage of an equivalent center tapped transformer used in full wave rectifier circuit.

Disadvantages

- Bridge rectifier circuit looks very complex
- More power loss as compared to the Center tapped full wave rectifier

3.2 Analysis of half wave, full wave center tapped and Bridge rectifiers and calculate:

3.2.1 DC output current and voltage 3.2.2 RMS output current and voltage 3.2.3 Rectifier efficiency 3.2.4 Ripple factor 3.2.5 Regulation 3.2.6 Transformer utilization factor 3.2.7 Peak inverse voltage

Analysis of Half Wave Rectifier:

The following are under the head of analysis of a half wave rectifier.

- i. D.C output current & voltage
- ii. RMS output current & voltage
- iii. Rectifier efficiency
- iv. Ripple factor
- v. Voltage Regulation
- vi. Transformer Utilization Factor (TUF)
- vii. Peak Inverse Voltage (PIV)

Average or Dc Value of Output Voltage and Load Current

Mathematically, the output voltage of a Half wave rectifier may be given as

$$v_o = V_m \sin \omega t \quad \text{for } 0 \leq \omega t \leq \pi$$

$$= 0 \quad \text{for } \pi \leq \omega t \leq 2\pi$$

We have to find the d.c or average value of output voltage which is expressed as

we know that $V_{avg} = V_{dc} = \frac{\text{Area under the curve over the full cycle}}{\text{Base}}$

But
$$\text{Area} = \int_0^{2\pi} v_o \cdot d(\omega t) = \int_0^{\pi} v_o \cdot d(\omega t) + \int_{\pi}^{2\pi} v_o \cdot d(\omega t)$$

Using the equation (4.2), we get

$$\text{Area} = \int_0^{\pi} V_m \sin \omega t \cdot d(\omega t) + \int_{\pi}^{2\pi} 0 \cdot d(\omega t)$$

$$\text{Area} = V_m [-\cos \omega t]_0^{\pi} + 0 \quad \text{or} \quad \text{Area} = V_m [-\cos \pi - (-\cos 0)]$$

$$\text{Area} = V_m \cdot [1 + 1] = 2 V_m$$

From equation we get

$$V_{dc} = \frac{2V_m}{2\pi} = \frac{V_m}{\pi} = 0.318 V_m$$

Hence, the d.c. value of output voltage is 31.8 percent of the maximum a.c. input voltage

Similarly, average or d.c. value of load current may be found as follows:

$$I_{avg} = I_{dc} = \frac{V_{dc}}{R_L}$$

But, V_{dc} is given as

$$V_{dc} = \frac{V_m}{\pi}$$

Therefore,

$$I_{dc} = \frac{V_m}{\pi R_L} = \frac{I_m}{\pi}$$

Scanned with CamScanner

$$I_{dc} = 0.318 I_m$$

RMS Current and Voltage

$$\begin{aligned}
 I_{\text{rms}} &= \left[\frac{1}{2\pi} \int_0^{2\pi} i^2 \cdot d(\omega t) \right]^{1/2} \\
 \therefore I_{\text{rms}} &= \left[\frac{1}{2\pi} \int_0^{\pi} I_m^2 \sin^2 \omega t d(\omega t) + \frac{1}{2\pi} \int_0^{2\pi} 0 d(\omega t) \right]^{1/2} \\
 &= \left[\frac{I_m^2}{2\pi} \int_0^{\pi} \left(\frac{1 - \cos 2\omega t}{2} \right) d(\omega t) \right]^{1/2} \\
 &= \left[\frac{I_m^2}{4\pi} \left\{ (\omega t) - \frac{\sin 2\omega t}{2} \right\}_0^{\pi} \right]^{1/2} \\
 &= \left[\frac{I_m^2}{4\pi} \left\{ \pi - 0 - \frac{\sin 2\pi}{2} + \sin 0 \right\} \right]^{1/2} \\
 &= \left[\frac{I_m^2}{4} \right]^{1/2} = \frac{I_m}{2}
 \end{aligned}$$

RMS value of output voltage is

$$\begin{aligned}
 V_{\text{rms}} &= \frac{I_{\text{rms}}}{R_L} \\
 &= \frac{I_m}{2R_L}
 \end{aligned}$$

$$V_{\text{rms}} = \frac{V_m}{2}$$

Rectifier Efficiency

Efficiency of a rectifier is defined as the ratio of DC power delivered to the load to the AC input power from the secondary winding of the transformer.

$$\eta = \frac{\text{d.c. power delivered to the load}}{\text{a.c. input power from transformer secondary}} = \frac{P_{\text{dc}}}{P_{\text{ac}}}$$

$$\text{Now } P_{\text{dc}} = (I_{\text{dc}})^2 \times R_L = \frac{I_m^2}{\pi^2} R_L$$

$$\text{Further } P_{\text{ac}} = P_a + P_r$$

where P_a = Power dissipated at the junction of diode

$$= I_{\text{rms}}^2 \times R_f = \frac{I_m^2}{4} \times R_f$$

and P_r = Power dissipated in the load resistance

$$= I_{\text{rms}}^2 \times R_L = \frac{I_m^2}{4} \times R_L$$

$$\therefore P_{\text{ac}} = \frac{I_m^2}{4} \times R_f + \frac{I_m^2}{4} \times R_L = \frac{I_m^2}{4} (R_f + R_L)$$

$$\eta = \frac{I_m^2 R_L / \pi^2}{I_m^2 (R_f + R_L) / 4} = \frac{4}{\pi^2} \cdot \frac{R_L}{(R_f + R_L)}$$

$$= \frac{4}{\pi^2} \cdot \frac{1}{1 + (R_f/R_L)} = \frac{0.406}{1 + (R_f/R_L)}$$

Percentage rectifier efficiency

$$\eta = \frac{40.6}{1 + (R_f/R_L)}$$

Theoretically the maximum value of rectifier efficiency of a half wave rectifier is 40.6% when $(R_f/R_L) = 0$

OR

$$\eta = \frac{P_{dc}}{P_{ac}}$$

Here $P_{dc} = I_{dc}^2 R_L$ and $P_{ac} = I_{rms}^2 (R_f + R_L)$

We know that $I_{dc} = \frac{I_m}{\pi}$ and $I_{rms} = \frac{I_m}{2}$

$$\text{So } \eta = \frac{P_{dc}}{P_{ac}} = \frac{4}{\pi^2} = .406 = 40.6 \%$$

Ripple Factor

- It is the ratio of RMS value of AC component of output voltage and the DC component of output voltage.
- Smaller the ripple more effective is the rectifier
- Ripple factor is a measure of purity of the output of a rectifier.

Ripple factor, $r = \frac{\text{The r.m.s. value of a.c. component of output voltage}}{\text{The d.c. component of output voltage}}$

$$r = \frac{V_r(\text{rms})}{V_{dc}} = \frac{I_r(\text{rms})}{I_{dc}}$$

Here

$V_r(\text{rms})$ = The r.m.s. value of the a.c. component of the output voltage

V_{dc} = The average or d.c. value of the output voltage

$I_r(\text{rms})$ = The r.m.s. value of the a.c. component of current

I_{dc} = The average or d.c. value of the load current

But, the r.m.s. value of the rectified output load current is given by the expression

$$I_{rms} = \sqrt{I_{dc}^2 + I_r(\text{rms})^2}$$

Dividing both sides by I_{dc}

$$\frac{I_{rms}}{I_{dc}} = \sqrt{\frac{I_{dc}^2 + I_r(\text{rms})^2}{I_{dc}^2}}$$

$$\frac{I_{rms}}{I_{dc}} = \sqrt{1 + \left[\frac{I_r(\text{rms})}{I_{dc}}\right]^2}$$

Simplifying the above equation, we get

$$\frac{I_r(\text{rms})}{I_{dc}} = \sqrt{\left(\frac{I_{rms}}{I_{dc}}\right)^2 - 1}$$

or ripple factor, $r = \sqrt{\left(\frac{I_{rms}}{I_{dc}}\right)^2 - 1}$

For half wave rectifier $I_{rms} = \frac{I_m}{2}$ & $I_{dc} = \frac{I_m}{\pi}$

So $r = 1.21$

OR

$$\Gamma = \frac{I_r(\text{rms})}{I_{dc}}$$

The rectified output load current is

$$I_{rms} = \sqrt{I_{dc}^2 + I_r(\text{rms})^2}$$

$$I_r(\text{rms}) = \sqrt{I_{rms}^2 - I_{dc}^2}$$

We know that $I_{dc} = \frac{V_m}{\pi}$ and $I_{rms} = \frac{V_m}{2}$

So $I_r(\text{rms}) = 0.386 I_m$

$$\Gamma = \frac{I_r(\text{rms})}{I_{dc}} = \frac{0.386 I_m}{\frac{I_m}{\pi}} = 1.21$$

Voltage Regulation

The variation of DC output voltage as a function of DC load current is called voltage regulation.

Voltage regulation is generally expressed as a percentage i.e.

$$\% \text{ voltage regulation} = \frac{V_{\text{no load}} - V_{\text{full load}}}{V_{\text{full load}}}$$

Transformer Utilization Factor(TUF)

The DC power to be delivered to the load in a rectifier circuit decides the AC rating of the transformer used in the circuit.

So transformer utilization factor is defined as

$$\text{TUF} = \frac{\text{DC power to be delivered to the load}}{\text{AC rating of the transformer secondary}}$$

Peak Inverse Voltage (PIV)

- The maximum voltage across the diode in the reverse direction is called peak inverse voltage.
- Hence for a half wave rectifier, peak inverse voltage (PIV) is V_m .

Analysis of Center Tap Full Wave Rectifier:

The following are under the head of analysis of a center tap fullwave rectifier.

- D.C output current & voltage
- RMS output current & voltage
- Rectifier efficiency
- Ripple factor
- Voltage Regulation
- Transformer Utilization Factor (TUF)
- Peak Inverse Voltage (PIV)

D.C Output Current & Voltage

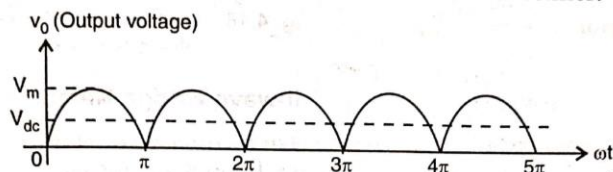

Fig. 4.20. Average or d.c. value of output voltage

Mathematically, the output voltage may be expressed as

$$v_o = \begin{cases} V_m \sin \omega t & \text{for } 0 \leq \omega t \leq \pi \\ -V_m \sin \omega t & \text{for } \pi \leq \omega t \leq 2\pi \end{cases} \dots$$

Here minus sign indicates that during the second-half cycle, the sine wave is inverted.

We know that average or d.c. value of voltage is given as

$$V_{\text{avg}} = V_{\text{dc}} = \frac{\text{Area under the curve over the full cycle}}{\text{Base}} \dots$$

$$\text{But Area} = \int_0^{2\pi} v_o \cdot d(\omega t)$$

$$\text{Area} = \int_0^{\pi} v_o \cdot d(\omega t) + \int_{\pi}^{2\pi} v_o \cdot d(\omega t)$$

$$\text{Area} = \int_0^{\pi} V_m \sin \omega t \cdot d(\omega t) + \int_{\pi}^{2\pi} -V_m \sin \omega t \cdot d(\omega t) = [-V_m \cos \omega t]_0^{\pi} + [V_m \cos \omega t]_{\pi}^{2\pi}$$

$$\text{Area} = V_m [-\cos \pi + \cos 0] + [\cos 2\pi - \cos \pi] V_m = V_m [1+1+1+1] \quad \text{or} \quad \text{Area} = 4 V_m$$

$$V_{dc} = \frac{\text{Area}}{\text{Base}} = \frac{4 \cdot V_m}{2\pi} = \frac{2V_m}{\pi} = 0.636 V_m$$

Similarly, average or d.c. value of load current is

$$I_{dc} = \frac{V_{dc}}{R_L} = \frac{2V_m}{\pi R_L} = \frac{2I_m}{\pi} \quad \left[\text{Since, } \frac{V_m}{R_L} = I_m \right]$$

Therefore, $I_{dc} = 0.636 I_m$

In all above calculations, the diodes have been assumed ideals for simplicity.

OR

$$\text{Area} = \int_0^{\pi} V_o d(\omega t)$$

$$= \int_0^{\pi} V_m \sin \omega t$$

$$= V_m [-\cos \pi + \cos 0] = 2 V_m$$

$$\text{So } V_{dc} = \frac{2 V_m}{\pi} = 0.6362 V_m$$

$$\text{And } I_{dc} = \frac{2 I_m}{\pi} = 0.6362 I_m$$

RMS Output Current & Voltage

$$I_{rms} = \sqrt{\frac{1}{\pi} \int_0^{\pi} i_L^2 d(\omega t)} = \sqrt{\frac{1}{\pi} \int_0^{\pi} I_m^2 \sin^2 \omega t d(\omega t)}$$

$$I_{rms} = \sqrt{\frac{I_m^2}{\pi} \int_0^{\pi} \frac{(1 - \cos 2\omega t)}{2} d(\omega t)}$$

$$I_{rms} = \sqrt{\frac{I_m^2}{\pi} \left[\frac{\omega t}{2} - \frac{\sin 2 \omega t}{2 \omega} \right]_0^{\pi}}$$

$$I_{rms} = \frac{I_m}{\sqrt{2}}$$

So $V_{rms} = \frac{V_m}{\sqrt{2}}$

Rectifier Efficiency

$$\eta = \frac{P_{dc}}{P_{ac}}$$

Now $P_{dc} = (V_{dc})^2 / R_L = (2 V_m / \pi)^2 / R_L$

and $P_{ac} = (V_{rms})^2 / R_L = (V_m / \sqrt{2})^2 / R_L$

$$\therefore \eta = \frac{P_{dc}}{P_{ac}} = \frac{(2 V_m / \pi)^2}{(V_m / \sqrt{2})^2} = \frac{8}{\pi^2}$$
$$= 0.812 = 81.2\%$$

The rectifier efficiency may be calculated in the following way :

The d.c. output power $P_{dc} = I_{dc}^2 R_L = \frac{4 I_m^2}{\pi^2} \times R_L$

The a.c. Input power $P_{ac} = I_{rms}^2 (R_f + R_L) = \frac{I_m^2}{2} (R_f + R_L)$

$$\therefore \eta = \frac{4 I_m^2 R_L / \pi^2}{I_m^2 (R_f + R_L) / 2} = \frac{8}{\pi^2} \cdot \frac{R_L}{(R_f + R_L)}$$
$$= \frac{0.812}{\{1 + (R_f / R_L)\}}$$

$$\therefore \text{Percentage efficiency} = \frac{81.2}{1 + (R_f / R_L)}$$
$$= 81.2\% \text{ if } R_f = 0$$

Thus fullwave rectifier has efficiency twice that of halfwave rectifier.

Ripple Factor

- It is the ratio of RMS value of AC component of output voltage and the DC component of output voltage.
- Smaller the ripple more effective is the rectifier
- Ripple factor is a measure of purity of the output of a rectifier.

$$r = \frac{\text{RMS value of AC component of output voltage}}{\text{DC component of output voltage}}$$
$$= \frac{v_r(\text{rms})}{v_{dc}} = \frac{I_r(\text{rms})}{I_{dc}}$$
$$= 0.482$$

Peak Inverse Voltage (PIV)

- The maximum voltage across the diode in the reverse direction is called peak inverse voltage.
- Hence for a half wave rectifier, peak inverse voltage (PIV) is $2V_m$.

COMPARISON OF RECTIFIER CIRCUITS

Sl. No.	Parameters	HWR	Centre Tapped FWR	Bridge FWR
1.	Number of diodes	1	2	4
2.	Centre tapped transformer	Not required	Required	Not required
3.	d.c. load current (I_{dc})	$\frac{I_m}{\pi}$	$\frac{2I_m}{\pi}$	$\frac{2I_m}{\pi}$
4.	No load d.c. voltage (V_{dc})	$\frac{V_m}{\pi}$	$\frac{2V_m}{\pi}$	$\frac{2V_m}{\pi}$
5.	RMS load current (I_{rms})	$\frac{I_m}{2}$	$\frac{I_m}{\sqrt{2}}$	$\frac{I_m}{\sqrt{2}}$
6.	RMS load voltage (V_{rms})	$\frac{V_m}{2}$	$\frac{V_m}{\sqrt{2}}$	$\frac{V_m}{\sqrt{2}}$
7.	Maximum efficiency (% η)	41%	81.2%	81.2%
8.	Ripple factor (γ)	121%	48%	48%
9.	Ripple frequency (f_r)	f_s	$2f_s$	$2f_s$
10.	Peak inverse voltage (PIV)	V_m	$2V_m$	V_m
11.	Transformer utilization factor (TUF)	0.286	0.692	0.812
12.	Voltage regulation	Good	Better	Good
13.	Form factor	1.57	1.11	1.11

FILTER

Filter is a circuit which removes the unwanted AC components of the rectifier output and allows only the DC component to reach the load.

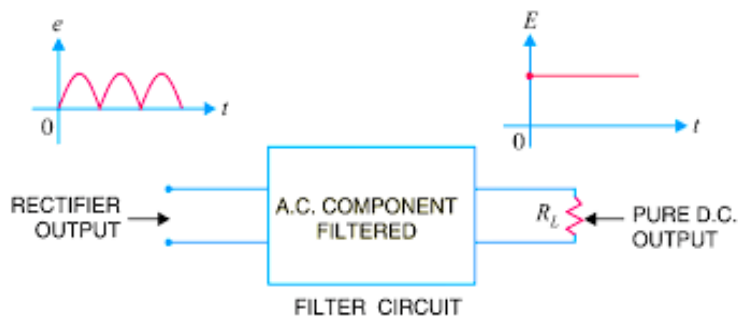

A filter circuit consists of passive circuit elements i.e. Inductor, Capacitor, Resistor and their combinations.

Some of the important filter circuits are

- i. Inductor filter
- ii. Inductor-capacitor(LC) filter
- iii. Capacitor filter
- iv. Π filter

Inductor Filter

- As an inductor allows DC and blocks AC, a filter called Inductor filter. It is also called Choke filter.

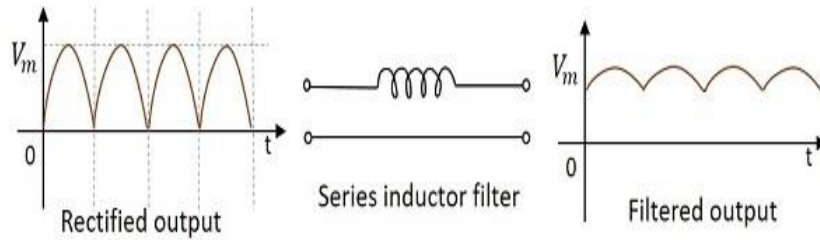

- It can be constructed by connecting the inductor in series between the rectifier and the load.
- When the rectified output passes through an inductor, it offers a high resistance to the AC components and no resistance to DC components.
- Therefore, AC component of the rectified output is blocked and only DC components reaches at the load.

Capacitor Filter

- As a capacitor allows AC through it and blocks DC, a filter is called capacitor filter.

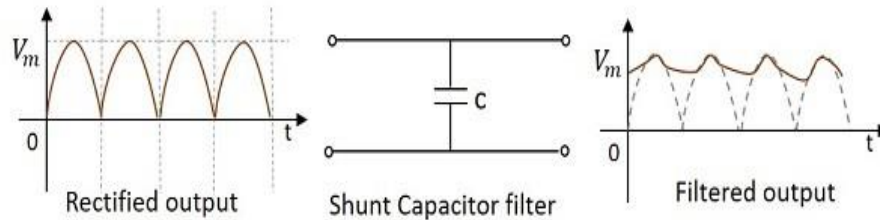

- It can be constructed using a capacitor connected in shunt across load resistor.
- The rectified output when passed through this filter, the AC components present in the signal are grounded through the capacitor which allows AC components.
- The remaining DC components present in the signal are collected at the ground.

Π Filter

- Here two capacitors and one inductor are connected in the form of Π shaped network.

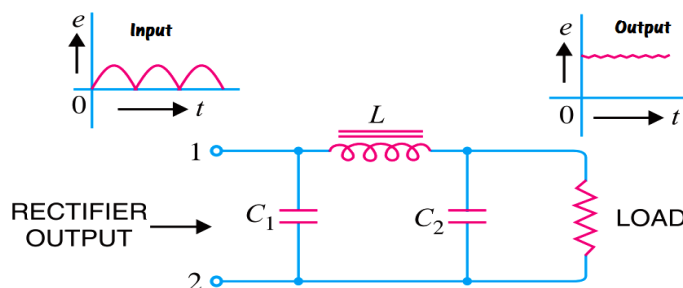

- It is also called as capacitor input filter or CLC filter.
- A capacitor in parallel then an inductor in series followed by another capacitor in parallel makes this circuit.
- ❖ **Capacitor C_1** : This filter capacitor offers high reactance to DC and low reactance to AC signal. After grounding the AC components present in the signal, the signal passes to the inductor for further filtration.
- ❖ **Inductor L** : This inductor offers low reactance to DC components while blocking the AC components if any got managed to pass through the capacitor C_1 .

- ❖ **Capacitor C₂**: Now the signal is further smoothed using this capacitor so that it allows any AC component present in the signal, which the inductor has failed to block.

4. TRANSISTORS

The term Transistor was derived from the words TRANSFER and RESISTOR. It transfers an input signal current from a low resistance circuit to a high resistance circuit.

A Transistor is a three terminal semiconductor device that regulates current or voltage flow and acts as a switch or gate for signals.

Uses of a transistor

- A transistor acts as an Amplifier, where the signal strength has to be increased.
- A transistor also acts as a switch to choose between available options.
- It also regulates the incoming current and voltage of the signals.

Transistor classification:

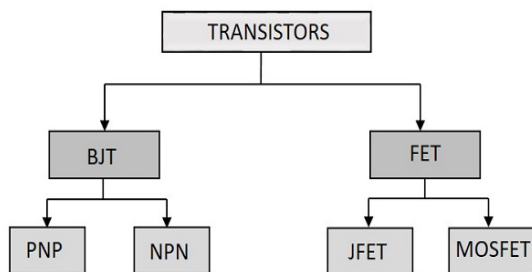

4.1 Principle of Bipolar junction transistor

- A Bipolar Junction Transistor is a type of transistor that uses both electron and holes as charge carriers.
- The Transistor is a three terminal solid state device which is formed by connecting two diodes back to back. Hence it has got two PN junctions.
- BJT are of two types namely NPN and PNP based on doping types of the three main terminals.

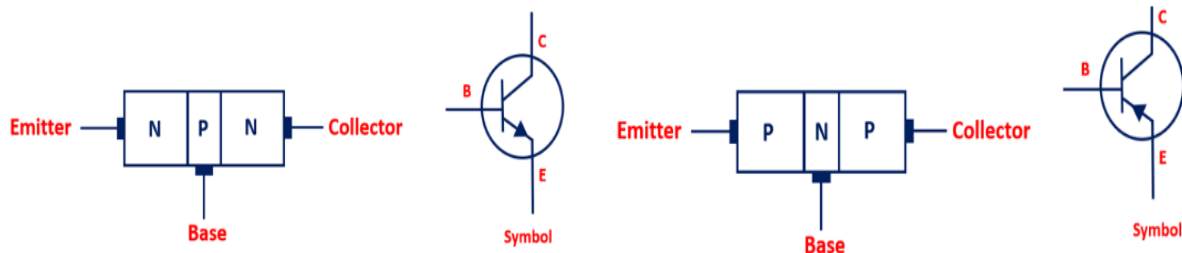

- The three terminals drawn from the transistor indicate Emitter, Base and Collector terminals. They have their functionality as discussed below.

Emitter

- Emitter has moderate size and is heavily doped as its main function is to supply a number of majority carriers, i.e. either electrons or holes.
- As this emits electrons, it is called as an Emitter. This is simply indicated with the letter E.

Base

- The middle layer is the Base region and is indicated by the letter B. This is thin and lightly doped.
- Its main function is to pass the majority carriers from the emitter to the collector.

Collector

- The right side material in the above figure can be understood as a Collector. Its name implies its function of collecting the carriers. This is indicated by the letter C.

- This is a bit larger in size than emitter and base. It is moderately doped.

Transistor Biasing

- A transistor is a combination of two diodes, so it has two junctions. As one junction is between the emitter and base, that is called as Emitter-Base junction and likewise, the other is Collector-Base junction.
- Biasing is controlling the operation of the circuit by providing power supply. The function of both the PN junctions is controlled by providing bias to the circuit through some dc supply. The figure below shows how a transistor is biased. Biasing are two type 1. Forward bias 2. Reverse Bias

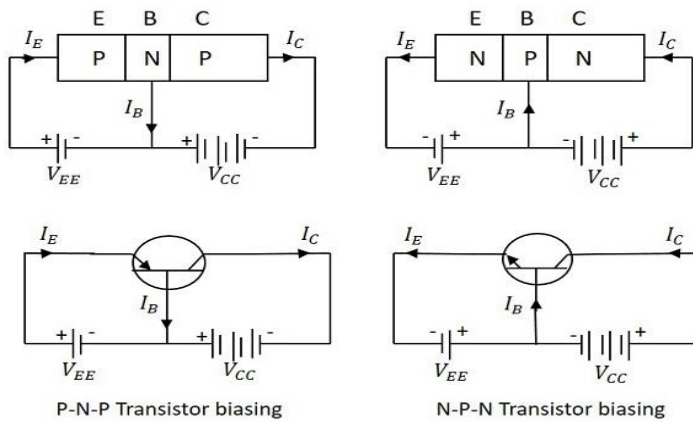

- The N-type material is provided negative supply and P-type material is given positive supply to make the circuit **Forward bias**.
- The N-type material is provided positive supply and P-type material is given negative supply to make the circuit **Reverse bias**.
- By applying the power, the emitter base junction is always forward biased as the emitter resistance is very small. The collector base junction is reverse biased and its resistance is a bit higher. A small forward bias is sufficient at the emitter junction whereas a high reverse bias has to be applied at the collector junction.
- The direction of current indicated in the circuits above, also called as the Conventional Current, is the movement of hole current which is opposite to the electron current.

Operation of PNP Transistor

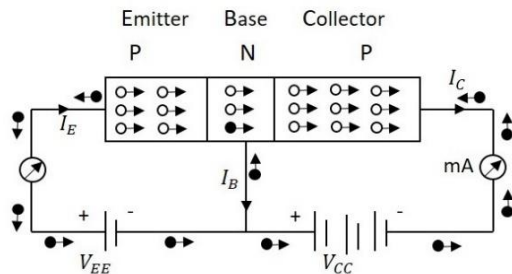

- Here emitter-base junction is forward biased and collector-base junction is reverse biased.
- The voltage V_{EE} provides a positive potential at the emitter which repels the holes in the P-type material and these holes cross the emitter-base junction, to reach the base region.
- There a very low percent of holes re-combine with free electrons of N-region. This provides very low current which constitutes the base current I_B .
- The remaining holes cross the collector-base junction, to constitute collector current I_C , which is the hole current.

- As a hole reaches the collector terminal, an electron from the battery negative terminal fills the space in the collector. This flow slowly increases and the electron minority current flows through the emitter, where each electron entering the positive terminal of V_{EE} , is replaced by a hole by moving towards the emitter junction. This constitutes emitter current I_E .

Operation of NPN Transistor

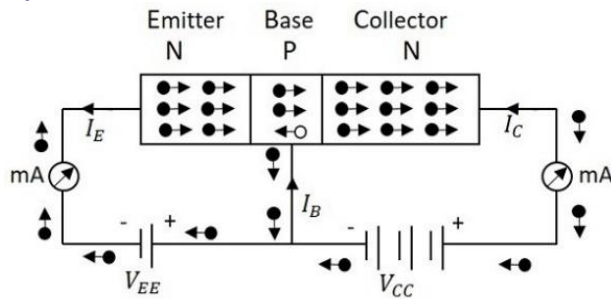

- Here emitter-base junction is forward biased and collector-base junction is reverse biased.
- The voltage V_{EE} provides a negative potential at the emitter which repels the electrons in the N-type material and these electrons cross the emitter-base junction, to reach the base region.
- There, a very low percent of electrons re-combine with free holes of P-region. This provides very low current which constitutes the base current I_B .
- The remaining holes cross the collector-base junction, to constitute the collector current I_C .
- As an electron reaches out of the collector terminal, and enters the positive terminal of the battery, an electron from the negative terminal of the battery V_{EE} enters the emitter region. This flow slowly increases and the electron current flows through the transistor.

Advantages of Transistors

- ✓ High voltage gain.
- ✓ Lower supply voltage is sufficient.
- ✓ Most suitable for low power applications.
- ✓ Smaller and lighter in weight.
- ✓ Mechanically stronger than vacuum tubes.

There are few disadvantages such as they cannot be used for high power applications due to lower power dissipation. They have lower input impedance and they are temperature dependent.

4.2 Different modes of operation of transistor

The transistor can be operated in three modes:

- Cut-off mode
- Saturation mode
- Active mode

In order to operate transistor in one of these regions, supply dc voltage to the NPN or PNP transistor. Based on the polarity of the applied dc voltage, the transistor operates in any one of these regions.

Cut-Off Mode

- In the cutoff mode, both the junctions of the transistor (emitter to base and collector to base) are reverse biased.

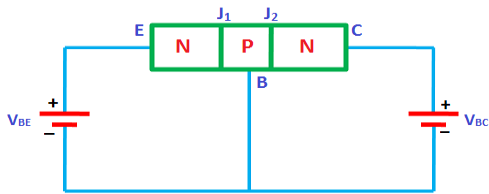

- In other words, if two p-n junctions as two p-n junction diodes, both the diodes are reverse biased in cutoff mode.
- In reverse bias condition, no current flows through the device. Hence, no current flows through the transistor. Therefore, the transistor is in OFF state and acts like an open switch.
- The cutoff mode of the transistor is used in switching operation for switch OFF application.

Saturation Mode

- In the saturation mode, both the junctions of the transistor (emitter to base and collector to base) are forward biased.
- In other words, if two p-n junctions as two p-n junction diodes, both the diodes are forward biased in saturation mode. In forward bias condition, current flows through the device. Hence, electric current flows through the transistor.

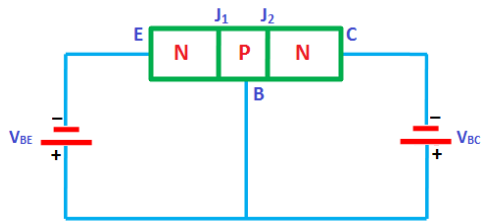

- In saturation mode, free electrons (charge carriers) flows from emitter to base as well as from collector to base. As a result, a huge current will flow to the base of transistor. Therefore, the transistor in saturation mode will be in ON state and acts like a closed switch.
- The saturation mode of the transistor is used in switching operation for switch ON application.

Active Mode

- In the active mode, one junction (emitter to base) is forward biased and another junction (collector to base) is reverse biased. In other words, if two p-n junctions as two p-n junction diodes, one diode will be forward biased and another diode will be reverse biased.

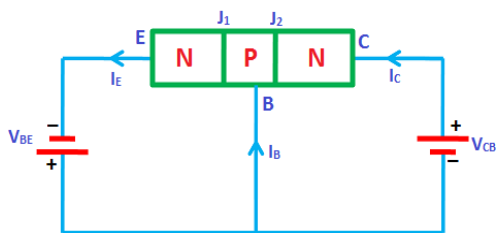

- The active mode of operation is used for the amplification of current.

From the above discussion, the transistor works as an ON/OFF switch in saturation and cutoff modes whereas it works as an amplifier of current in active mode.

4.3 Current components in a transistor

Current Components in a Transistor

- The conduction of current in NPN transistor is owing to electrons and in PNP transistor, it is owing to holes. The direction of current flow will be in opposite direction.
- Here the current components in a PNP transistor with common base configuration. The emitter-base junction (J_E) is forward biased and the collector-base junction (J_C) is reversed biased.

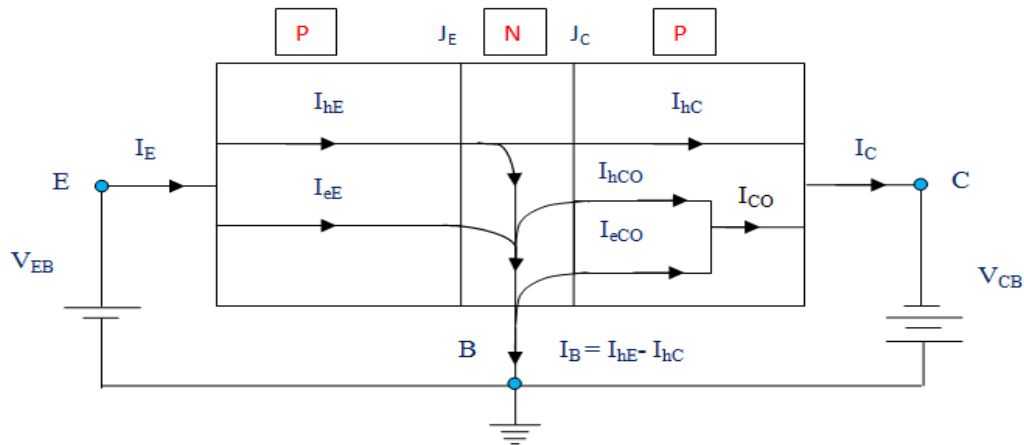

- The current arrives the transistor through the emitter called emitter current (I_E). This current consists of two constituents – **Hole current** (I_{hE}) and **Electron current** (I_{eE}). I_{eE} is due to passage of electrons from base to emitter and I_{hE} is due to passage of holes from emitter to base.

$$I_E = I_{hE} + I_{eE}$$

Normally, the emitter is heavily doped compared to base in transistor. So, the Electron current is negligible compared to Hole current. Thus we can conclude that, the whole emitter current in this transistor is due to the passage of holes from the emitter to the base.

- Some of the holes which are crossing the junction J_E (emitter junction) combines with the electrons present in the base (N-type). Thus, every holes crossing J_E will not arrive at J_C . The remaining holes will reach the collector junction which produces the hole current component, I_{hC} .

- There will be bulk recombination in the base and the current leaving the base will be

$$I_B = I_{hE} - I_{hC}$$

The electrons in the base which are lost by the recombination with holes (injected into the base across J_E) are refilled by the electrons that enter into the base region. The holes which are arriving at the collector junction (J_C) will cross the junction and it will go into the collector region.

- When the emitter circuit is open circuited, then $I_E = 0$ and $I_{hC} = 0$. In this condition, the base and collector will perform as reverse biased diode. Here, the collector current, I_C will be same as reverse saturation current (I_{CO} or I_{CBO}).

I_{CO} is small reverse current which passes through the PN junction diode. This is due to thermally generated minority carriers which are pushed by barrier potential. This reverse current increase; if the junction is reverse biased and it will have the same direction as the collector current. This current attains a saturation value (I_0) at moderate reverse biased voltage.

- When the emitter junction is at forward biased (in active operation region), then the collector current will become

$$I_C = \alpha I_E + I_{CO}$$

The α is the large signal current gain which is a fraction of the emitter current which comprises of I_{hC} .

When the emitter is at closed condition, then $I_E \neq 0$ and collector current will be

$$I_C = I_{CO} + I_{hC}$$

In a PNP transistor, the reverse saturation current (I_{CBO}) will comprises of the current due to the

holes passing through the collector junction from the base to collector region (I_{hCO}) and the current due to the electrons which are passing through the collector junction in the opposite direction (I_{eCO}).

Therefore, $I_{CO} = I_{hCO} + I_{eCO}$

The total current entering into the transistor will be equal to the total current leaving the transistor (according to Kirchhoff's current law).

So, $I_E = I_C + I_B$ or $I_E = -(I_C + I_B)$

4.4 Transistor as an amplifier

- The transistor raises the strength of a weak signal and hence acts an amplifier. The transistor amplifier circuit is shown in the figure below.
- The emitter and base of the transistor are connected in forward biased and the collector base region is in reverse bias. The forward bias means the P-region of the transistor is connected to the positive terminal of the supply and the negative region is connected to the N-terminal and in reverse bias just opposite of it has occurred.

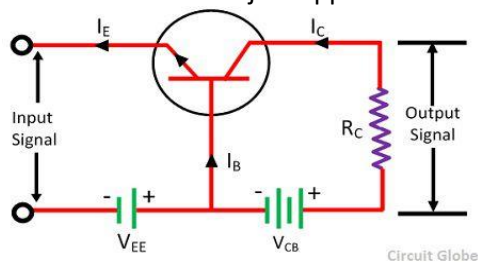

- The input signal or weak signal is applied across the emitter base and the output is obtained to the load resistor R_C which is connected in the collector circuit.
- The DC voltage V_{EE} is applied to the input circuit along with the input signal to achieve the amplification. The DC voltage V_{EE} keeps the emitter-base junction under the forward biased condition regardless of the polarity of the input signal and is known as a bias voltage.
- When a weak signal is applied to the input, a small change in signal voltage causes a change in emitter current because the input circuit has very low resistance. This change is almost the same in collector current because of the transmitter action.
- In the collector circuit, a load resistor R_C of high value is connected. When collector current flows through such a high resistance, it produces a large voltage drop across it. Thus, a weak signal applied to the input circuit appears in the amplified form in the collector circuit.

4.5 Transistor circuit configuration & its characteristics

4.5.1 CB Configuration 4.5.2 Configuration 4.5.3 CC Configuration

Transistor Circuit Configuration

As the **Bipolar Transistor** is a three terminal device, there are basically three possible ways to connect it within an electronic circuit with one terminal being common to both the input and output. There are three different configurations of Transistors.

- **Common Base (CB) Configuration:** no current gain but voltage gain
- **Common Collector (CC) Configuration:** current gain but no voltage gain
- **Common Emitter (CE) Configuration:** current gain and voltage gain

Common Base Configuration

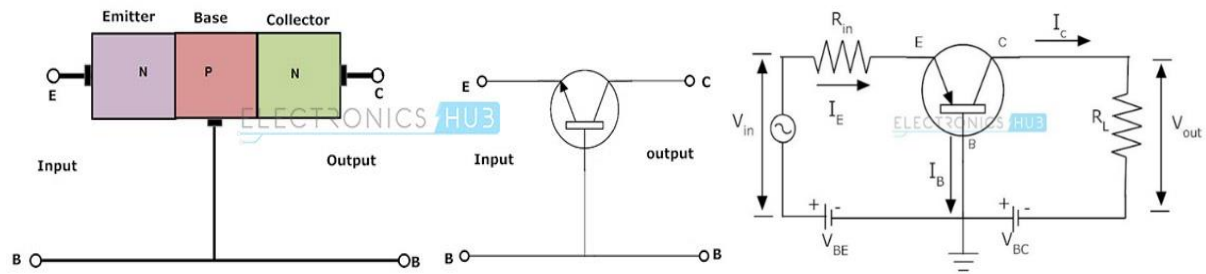

- In this configuration, base as common terminal for both input and output signals.
- Here the input is applied between the base and emitter terminals and the corresponding output signal is taken between the base and collector terminals with the base terminal grounded.
- The input parameters are V_{EB} and I_E and the output parameters are V_{CB} and I_C . The input current flowing into the emitter terminal must be higher than the base current and collector current to operate the transistor, therefore the output collector current is less than the input emitter current.
- The current gain is generally equal or less than to unity for this type of configuration. The input and output signals are in-phase in this configuration.
- Current gain in common base configuration is given as

$$\alpha = \frac{\text{output current}}{\text{Input current}}$$

$$\alpha = \frac{I_C}{I_E}$$

- The common base circuit is mainly used in single stage amplifier circuits, such as microphone pre amplifier or radio frequency amplifiers because of their high frequency response.

Input Characteristics

- Input characteristics are obtained between input current (I_E) and input voltage (V_{BE}) with constant output voltage (V_{CB}).
- Initially current is zero when V_{BE} is very small, then current start increasing exponentially when V_{BE} is greater than barrier potential. It means that input resistance is very small.
- Here $R_{in} = \frac{V_{EB}}{I_E}$ (when V_{CB} is constant)

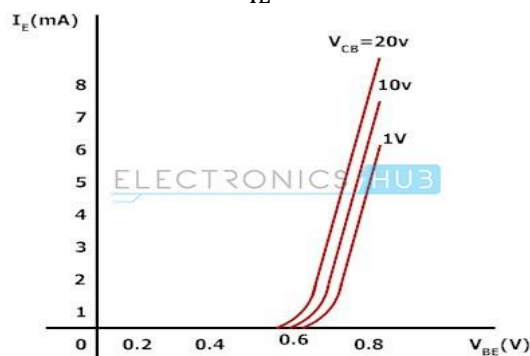

Output Characteristics

- The output characteristics of common base configuration are obtained between output current and output voltage with constant input current.
- The curve may be divided into three important regions namely saturation region, active region and cut off region.
- Here, the output resistance value is given as.

$$R_{out} = \frac{V_{CB}}{I_C} \text{ (when } I_E \text{ is constant)}$$

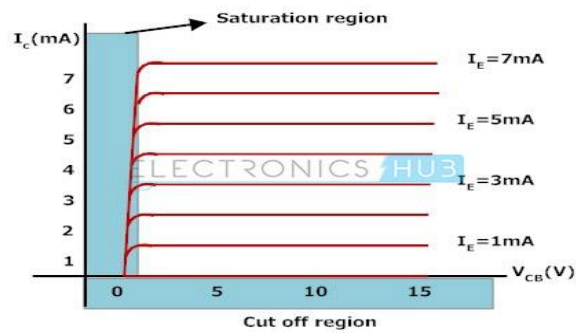

Common Collector Configuration

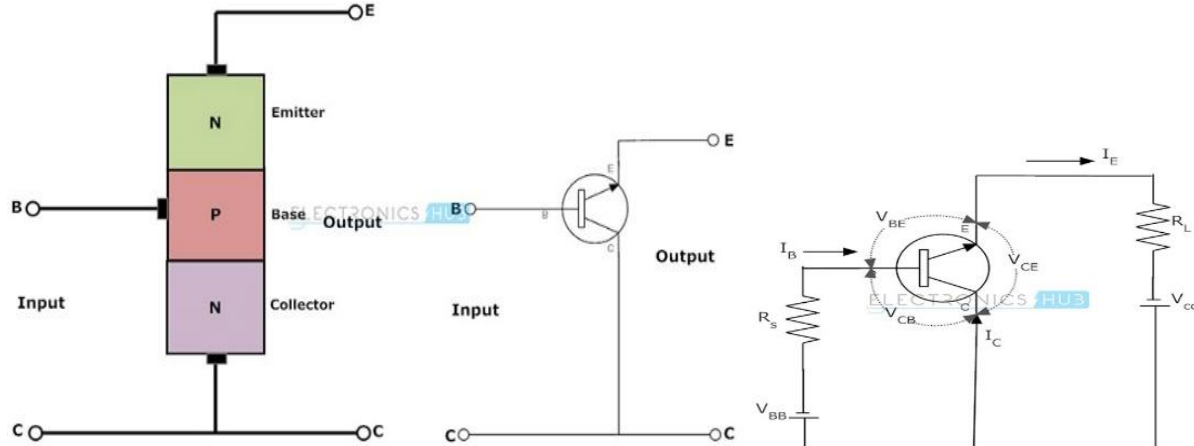

- In this configuration collector terminal as common for both input and output signals.
- This configuration is also known as emitter follower configuration because the emitter voltage follows the base voltage. This is mostly used as a buffer and impedance matching applications because of their high input impedance.
- In this configuration the input signal is applied between the base-collector region and the output is taken from the emitter-collector region. Here the input parameters are V_{BC} and I_B and the output parameters are V_{EC} and I_E .
- The common collector configuration has high input impedance and low output impedance. The input and output signals are in phase. Here also the emitter current is equal to the sum of collector current and the base current.

Now the current gain for this configuration.

$$A_i = \frac{\text{output current}}{\text{Input current}} = \gamma$$

$$A_i = \frac{I_E}{I_B} = \frac{I_C + I_B}{I_B} = \left(\frac{I_C}{I_B} \right) + 1$$

$$\text{So } \gamma = \beta + 1$$

- The voltage gain for this circuit is less than unity but it has large current gain because the load resistor in this circuit receives both the collector and base currents.

Input Characteristics

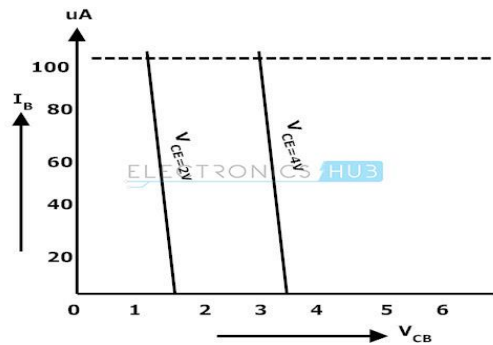

- Input characteristics are the relationship between the input current and input voltage keeping output voltage constant. Here input current is I_B and input voltage V_{BE} and output voltage is V_{CE} .
- The input characteristics of a common collector configuration are quite different from the common base and common emitter configurations because the input voltage V_{CB} is largely determined by V_{CE} level. Here,

$$V_{CE} = V_{BE} + V_{CB}$$

$$V_{BE} = V_{CE} - V_{CB}$$

- For fixed value of V_{CE} , as V_{CB} increased I_B decreases. But as V_{BE} increase then I_B increase.
- For larger value of V_{CE} the entire curve will shift right hand side.

Output Characteristics

- The operation of the common collector circuit is same as that of common emitter circuit. The output characteristics of a common collector circuit are obtained between the output voltage V_{CE} and output current I_E at constant input current I_B .
- In the operation of common collector circuit if the base current is zero then the emitter current also becomes zero. As a result, no current flows through the transistor
- If the base current increases, then the transistor operates in active region and finally reaches to saturation region.
- To plot the graph, keep the I_B at constant value and vary the V_{EC} value for various points.

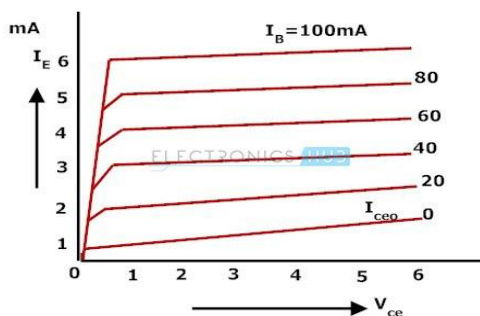

Common Emitter Configuration

- In this configuration emitter as common terminal for both input and output. Here the input is applied between base-emitter region and the output is taken between collector and emitter terminals.
- In this configuration the input parameters are V_{BE} and I_B and the output parameters are V_{CE} and I_C .
- This type of configuration is mostly used in the applications of transistor based amplifiers.
- Here the emitter current is equal to the sum of small base current and the large collector current. i.e. $I_E = I_C + I_B$.
- The ratio between collector current and base current gives the current gain beta in common emitter configuration.

$$\text{Current gain } (\beta) = I_C / I_B$$

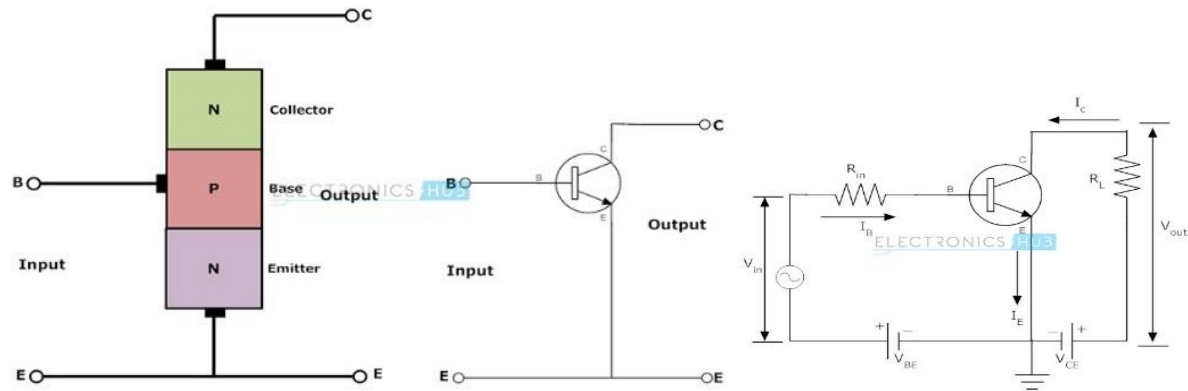

- The relationship between α and β is
Collector current $I_C = \alpha I_E = \beta I_B$
- This configuration is mostly used one among all the three configurations. It has medium input and output impedance values. It also has the medium current and voltage gains. But the output signal has a phase shift of 180° i.e. both the input and output are inverse to each other.

Input Characteristics

- The input characteristics of common emitter configuration are obtained between input current I_B and input voltage V_{BE} with constant output voltage V_{CE} .
- Initially I_B current is zero up to threshold voltage, after that it increases exponentially.
- As V_{CE} increases I_B decreases so that the curve shifts right hand side.
- The base current I_B increases with the increases in the emitter base voltage V_{BE} . Thus the input resistance of the CE configuration is comparatively higher that of CB configuration.

$$R_{in} = V_{BE}/I_B \text{ (when } V_{CE} \text{ is at constant)}$$

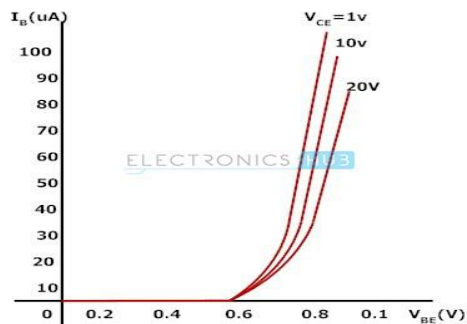

Output Characteristics

- The output characteristics of common emitter configuration are obtained between the output current I_C and output voltage V_{CE} with constant input current I_B .
- The curve may be divided into three important regions namely saturation region, active region and cut off region.
- Output resistance from this graph is given by.

$$R_{out} = V_{CE}/I_C \text{ (when } I_B \text{ is at constant)}$$

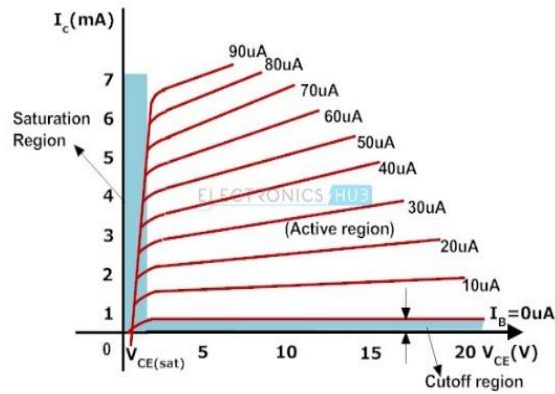

Relation between α, β & γ

$$I_E = I_B + I_C$$

$$\frac{I_E}{I_C} = \frac{I_B}{I_C} + 1$$

$$\frac{1}{\alpha} = \frac{1}{\beta} + 1$$

$$\frac{1}{\alpha} = \frac{1+\beta}{\beta}$$

$$\boxed{\alpha = \frac{\beta}{1+\beta}} \rightarrow \textcircled{1}$$

$$\boxed{\beta = \frac{\alpha}{1-\alpha}} \rightarrow \textcircled{2}$$

$$I_E = I_B + I_C$$

$$\frac{I_E}{I_B} = \frac{I_B}{I_B} + \frac{I_C}{I_B}$$

$$\boxed{\gamma = 1 + \beta}$$

from 2)

$$\gamma = 1 + \frac{\alpha}{1-\alpha}$$

$$\gamma = \frac{1-\alpha + \alpha}{1-\alpha}$$

$$\boxed{\gamma = \frac{1}{1-\alpha}}$$

Relation between α, β and γ

$$\boxed{\gamma = 1 + \beta = \frac{1}{1-\alpha}}$$

5. TRANSISTOR CIRCUIT

DC Load Line

- The DC load represents the desirable combinations of the collector current and the collector-emitter voltage. It is drawn when no signal is given to the input, and the transistor becomes bias.
- Consider a Common Emitter NPN transistor circuit shown in the figure below where no signal is applied to the input side.

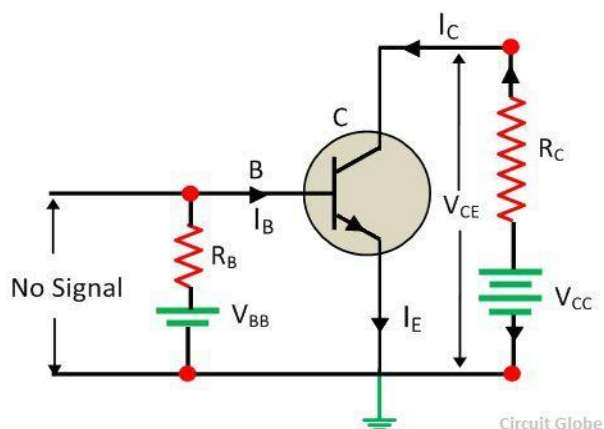

By applying Kirchhoff's voltage law to the collector circuit, we get,

$$V_{CC} = V_{CE} + I_C R_C$$

$$V_{CE} = V_{CC} - I_C R_C \dots \text{equ}(1)$$

The above equation shows that the V_{CC} and R_C are the constant value, and it is represented by straight line. This load line is known as a DC load line.

1. The collector-emitter voltage V_{CE} is maximum when the collector current $I_C = 0$ then from the equation (1) we get,

$$V_{CE} = V_{CC} - 0 \times R_C$$

$$V_{CE} = V_{CC}$$

The first point A ($OA = V_{CC}$) on the collector-emitter voltage axis shown in the figure above.

2. The collector current I_C becomes maximum when the collector-emitter voltage $V_{CE} = 0$ then from the equation (1) we get.

$$0 = V_{CC} - I_C R_C$$

$$I_C = \frac{V_{CC}}{R_C}$$

The DC load line curve of the above circuit is shown in the figure below.

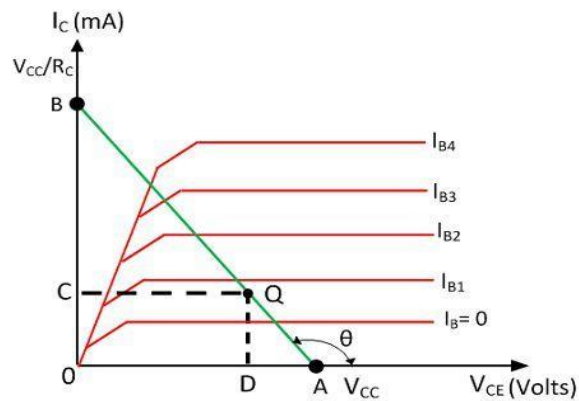

By adding the points, A and B, the DC load line is drawn. With the help of load line, any value of collector current can be determined.

Operating Point:

- The operating point is a point where the transistor can be operated efficiently.
- The dc load line superimposed on the output characteristics of a transistor is used to learn the operating point of the transistor
- Operating point must be suitably placed in the middle of the active region by suitable selection of external energy associated biasing circuit. If Q point is near saturation region or cut off region, some portion is clipped.

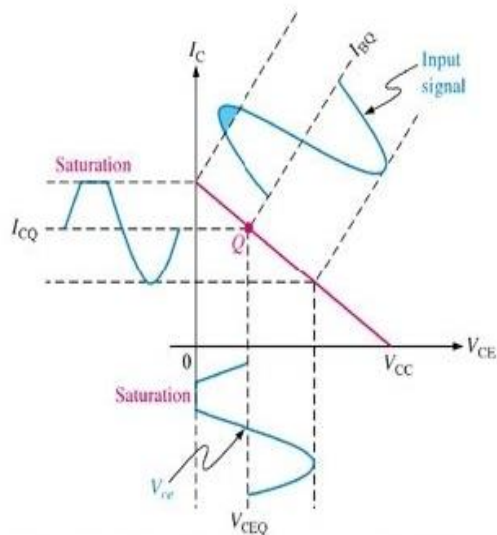

(a) Transistor is driven into saturation because the Q-point is too close to saturation for the given input signal.

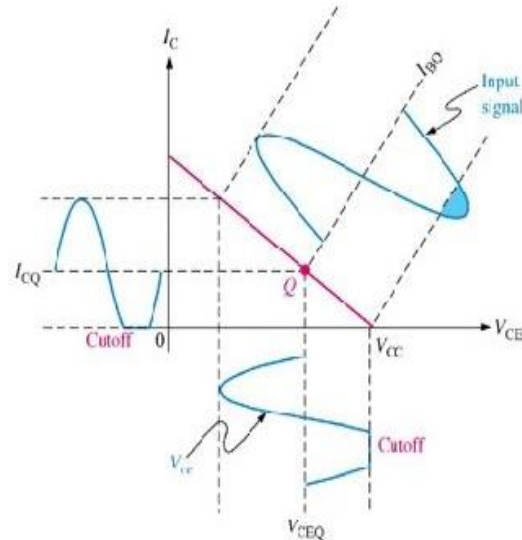

(b) Transistor is driven into cutoff because the Q-point is too close to cutoff for the given input signal.

5.1 Transistor biasing

Transistor Biasing

- The proper flow of zero signal collector current and the maintenance of proper collector emitter voltage during the passage of signal is known as **Transistor Biasing**.
- The circuit which provides transistor biasing is called as **Biasing Circuit**.

Need for DC biasing

- In order to operate transistor in the desired region we have to apply external DC voltage of correct polarity and magnitude to the two junctions of the transistor. This is nothing but the biasing of the transistor.
- The emitter base junction must be forward biased and collector base junction is reverse biased that is transistor should be in the active region, to be operated as an amplifier.
- For a transistor to be operated as a faithful amplifier, the operating point should be stabilized and must be at middle of the load line.

Factors affecting the operating point

- The main factor that affect the operating point is the temperature. The operating point shifts due to change in temperature.
- As temperature increases, the values of I_{CE} , β , V_{BE} gets affected.
 I_{CBO} gets doubled (for every 10° rise)
 V_{BE} decreases by 2.5mv (for every 1° rise)
- So the main problem which affects the operating point is temperature. Hence operating point should be made independent of the temperature so as to achieve stability. To achieve this, biasing circuits are introduced.

5.2 Stabilization

Stabilization

- The process of making the operating point independent of temperature changes or variations in transistor parameters is known as **Stabilization**.
- Once the stabilization is achieved, the values of I_C and V_{CE} become independent of temperature variations or replacement of transistor. A good biasing circuit helps in the stabilization of operating point.

Need for Stabilization

Stabilization of the operating point has to be achieved due to the following reasons.

- Temperature dependence of I_C
- Individual variations
- Thermal runaway

Temperature Dependence of I_C

As the expression for collector current I_C is

$$I_C = \beta I_B + I_{CEO}$$

$$= \beta I_B + (\beta + 1) I_{CBO}$$

The collector leakage current I_{CBO} is greatly influenced by temperature variations. To come out of this, the biasing conditions are set so that zero signal collector current $I_C = 1$ mA. Therefore, the operating point needs to be stabilized i.e. it is necessary to keep I_C constant.

Individual Variations

As the value of β and the value of V_{BE} are not same for every transistor, whenever a transistor is replaced, the operating point tends to change. Hence it is necessary to stabilize the operating point.

Thermal Runaway

As the expression for collector current I_C is

$$I_C = \beta I_B + I_{CEO}$$

$$= \beta I_B + (\beta + 1) I_{CBO}$$

The flow of collector current and also the collector leakage current causes heat dissipation. If the operating point is not stabilized, there occurs a cumulative effect which increases this heat dissipation.

The self-destruction of such an unstabilized transistor is known as **Thermal run away**.

In order to avoid **thermal runaway** and the destruction of transistor, it is necessary to stabilize the operating point, i.e., to keep I_C constant.

5.3 Stability factor

Stability Factor

It is defined as the degree of change in operating due to variation in temperature. There are three variables which are temperature dependent. Three stability factors are defined as follows,

$$S = \left(\frac{\partial I_C}{\partial I_{CO}} \right) \rightarrow \beta, V_{BE} \text{ Constant}$$

$$S' = \left(\frac{\partial I_C}{\partial V_{BE}} \right) \rightarrow \beta, I_{CO} \text{ Constant}$$

$$S'' = \left(\frac{\partial I_C}{\partial \beta} \right) \rightarrow I_{CO}, V_{BE} \text{ Constant}$$

Ideally, Stability factors should be zero to keep operating point stable and fixed.

Practically, Stability factors should have the value as minimum as possible.

Effect of change in I_{CO} , is more dominant over the change in β and V_{BE} . Hence S is calculated here.

$$S = \frac{dI_C}{dI_{CO}} \text{ at constant } I_B \text{ and } \beta$$

The rate of change of collector current I_C with respect to the collector leakage current I_{CO} at constant β and I_B is called **Stability factor**.

The general expression of stability factor for a CE configuration can be obtained as under.

$$I_C = \beta I_B + (\beta + 1) I_{CO}$$

Differentiating above expression with respect to I_C , we get

$$1 = \beta \frac{dI_B}{dI_C} + (\beta + 1) \frac{dI_{CO}}{dI_C}$$

Or

$$1 = \beta \frac{dI_B}{dI_C} + \frac{(\beta + 1)}{S}, \text{ Since } \frac{dI_{CO}}{dI_C} = \frac{1}{S}$$

$$\text{Or } S = \frac{(\beta + 1)}{1 - \beta \frac{dI_B}{dI_C}}$$

Hence the stability factor S depends on β , I_B and I_C .

5.4 Different method of Transistors Biasing

5.4.1 Base resistor method 5.4.2 Collector to base bias 5.4.3 Self bias or voltage divider method

Different Method of Transistor Biasing

The commonly used methods of transistor biasing are

- Base Resistor method/ Fixed Bias
- Collector to Base bias/Collector Feedback Bias
- Emitter Feedback Bias/Base bias with emitter feedback
- Voltage-divider bias/Self Bias
- Emitter Bias

All of these methods have the same basic principle of obtaining the required value of I_B and I_C from V_{CC} in the zero signal conditions.

5.4.1 Base Resistor Method

In this circuit, two D.C batteries V_{BB} and V_{CC} are used. The V_{BB} is a low value battery and V_{CC} is a high value battery. The fixed bias circuit may be replaced with single supply V_{CC} . In this circuit, both the base and collector resistors are connected to the positive side of the battery V_{CC} .

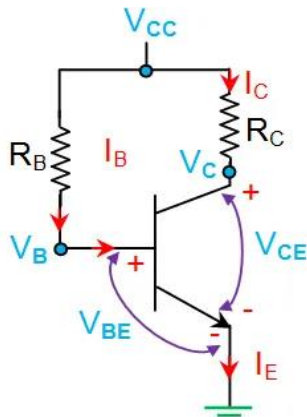

The base emitter junction is forward biased, as base is positive with respect to emitter.

Case (1)

Considering the input portion of the fixed bias circuit

Applying Kirchoff's voltage law for the input side

$$V_{CC} = I_B R_B + V_{BE} \dots\dots\dots(1)$$

or $I_B R_B = V_{CC} - V_{BE}$

or Base Current $I_B = \frac{V_{CC} - V_{BE}}{R_B} \dots\dots\dots(2)$

The values of voltage V_{CC} and V_{BE} are fixed, therefore the value of base current depends upon the base resistor R_B .

Hence, Base Current $I_B = \frac{V_{CC}}{R_B} \dots\dots\dots(3)$

Case (2)

Considering the output portion of the fixed bias circuit

Applying Kirchoff's voltage law for the output side, we get

$$R_C I_C + V_{CE} = V_{CC}$$

$$V_{CE} = V_{CC} - R_C I_C \dots\dots\dots(4)$$

The collector current I_C is given by the relation

$$I_C = \beta I_B + I_{CO}$$

As an approximation, neglecting I_{CO} , we have

$$I_C = I_B \beta = \beta \cdot \frac{V_{CC}}{R_B} = \frac{V_{CC}}{\beta / R_B} \dots\dots\dots(5)$$

The above relation shows that the collector current is β times greater than the base current and does not depend upon the collector resistor.

In this bias circuit collector current (I_C) and collector to emitter voltage (V_{CE}) are depend upon β . But β is strongly dependent upon temperature. So I_C and V_{CE} will vary with change in the value of β due to variation in temperature. Its means it is impossible to obtain a stable Q point in a Base Bias circuit.

Stability factor

We know that, $S = \frac{\beta+1}{1-\beta\left(\frac{dI_B}{dI_C}\right)}$

In fixed-bias method of biasing, I_B is independent of I_C so that, $\frac{dI_B}{dI_C} = 0$

Substituting the above value in the previous equation,

Stability factor, $S = \beta + 1$

Thus the stability factor in a fixed bias is $(\beta + 1)$ which means that I_C changes $(\beta + 1)$ times as much as any change in I_{C0} .

Advantages

- The circuit is simple.
- Only one resistor R_E is required.
- Biasing conditions are set easily.
- No loading effect as no resistor is present at base-emitter junction.

Disadvantages

- The stabilization is poor as heat development can't be stopped.
- The stability factor is very high. So, there are strong chances of thermal run away.

Hence, this method is rarely employed.

5.4.2 Collector to Base Bias

The collector to base bias circuit is same as base bias circuit except that the base resistor R_B is returned to collector, rather than to V_{CC} supply as shown in the figure below. Here R_B works as a feedback resistor.

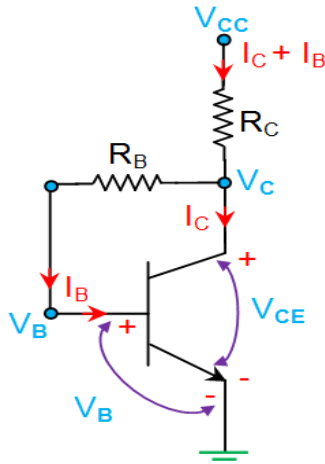

First, let us consider input or base- emitter loop

Applying Kirchoff's voltage law to this loop, we get

$$V_{CC} - (I_B + I_C) R_C - I_B R_B - V_{BE} = 0$$

$$(I_B + I_C) R_C + I_B R_B = V_{CC} - V_{BE}$$

$$I_B (R_C + R_B) + I_C R_C = V_{CC} - V_{BE}$$

$$I_B (R_C + R_B) + I_B \beta R_C = V_{CC} - V_{BE}$$

$$I_B [R_B + R_C(1 + \beta)] = V_{CC} - V_{BE}$$

$$I_B = \frac{V_{CC} - V_{BE}}{R_B + R_C(1 + \beta)} = \frac{V_{CC} - V_{BE}}{R_B + \beta R_C}$$

Collector current is given by

$$I_C = I_B \beta$$

Substitute value of I_B , we get

$$I_C = \beta \frac{V_{CC} - V_{BE}}{R_B + \beta R_C} = \frac{V_{CC} - V_{BE}}{R_C + R_B/\beta}$$

Since $V_{CC} \gg V_{BE}$

$$\text{Therefore, } I_C \approx \frac{V_{CC}}{R_C + R_B/\beta}$$

Let us consider the output or collector-emitter loop. Applying KVL, We get

$$V_{CC} = V_{CE} + (I_C + I_B) R_C$$

Since $I_C \gg I_B$, therefore $I_C + I_B \cong I_C$

$$V_{CE} = V_{CC} - I_C R_C$$

This circuit helps in improving the stability considerably. If the value of I_C increases, the voltage across R_C increases and hence the V_{CE} also increases. This in turn reduces the base current I_B .

Stability Factor:

We know that KVL of input side is

$$V_{CC} - (I_B + I_C) R_C - I_B R_B - V_{BE} = 0$$

$$I_B(R_C+R_B) + I_C R_C = V_{CC} - V_{BE}$$

$$I_B(R_C+R_B) = V_{CC} - V_{BE} - I_C R_C$$

$$I_B = \frac{V_{CC} - V_{BE} - I_C R_C}{R_B + R_C}$$

Differentiate the above equation w.r.t I_C , we have

$$\frac{dI_B}{dI_C} = \frac{0 - 0 - R_C}{R_B + R_C} = \frac{-R_C}{R_B + R_C}$$

Stability factor is given by the expression

$$S = \frac{\beta + 1}{1 - \beta \left(\frac{dI_B}{dI_C} \right)}$$

$$\text{Therefore, } S = \frac{1 + \beta}{1 + \beta \left(\frac{R_C}{R_C + R_B} \right)}$$

This value is smaller than $(1 + \beta)$ which is obtained for fixed bias circuit. Thus there is an improvement in the stability.

This circuit provides a negative feedback which reduces the gain of the amplifier. So the increased stability of the collector to base bias circuit is obtained at the cost of AC voltage gain.

Advantages

- The circuit is simple as it needs only one resistor.
- This circuit provides some stabilization, for lesser changes.

Disadvantages

- The circuit doesn't provide good stabilization.
- The circuit provides negative feedback.

5.4.3 Voltage Divider Bias

In Voltage divider circuit, two resistors R_1 and R_2 are employed, which are connected to V_{CC} and provide biasing. The resistor R_E employed in the emitter provides stabilization.

The name voltage divider comes from the voltage divider formed by R_1 and R_2 . The voltage drop across R_2 forward biases the base-emitter junction. This causes the base current and hence collector current flow in the zero signal conditions

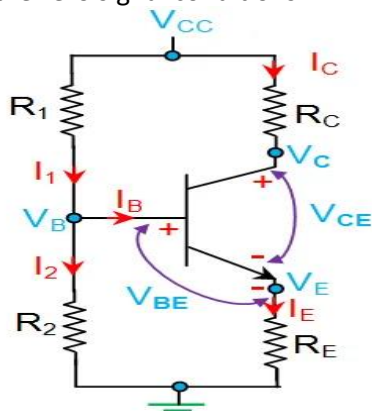

Suppose that the current flowing through resistance R_1 is I_1 . As base current I_B is very small, therefore, it can be assumed with reasonable accuracy that current flowing through R_2 is also I_1 .

Collector Current, I_C

From the circuit, it is evident that, $I_1 = \frac{V_{CC}}{R_1 + R_2}$

Therefore, the voltage across resistance R_2 is

$$V_2 = \left(\frac{V_{CC}}{R_1 + R_2} \right) R_2$$

Applying Kirchhoff's voltage law to the base circuit,

$$V_2 = V_{BE} + V_E$$

$$V_2 = V_{BE} + I_E R_E$$

$$I_E = \frac{V_2 - V_{BE}}{R_E}$$

Since $I_E \approx I_C$,

$$I_C = \frac{V_2 - V_{BE}}{R_E}$$

From the above expression, it is evident that I_C doesn't depend upon β . V_{BE} is very small that I_C doesn't get affected by V_{BE} at all. Thus I_C in this circuit is almost independent of transistor parameters and hence good stabilization is achieved.

Collector-Emitter Voltage, V_{CE}

Applying Kirchhoff's voltage law to the collector side,

$$V_{CC} = I_C R_C + V_{CE} + I_E R_E$$

Since $I_E \cong I_C$

$$= I_C R_C + V_{CE} + I_C R_E$$

$$= I_C (R_C + R_E) + V_{CE}$$

Therefore,

$$V_{CE} = V_{CC} - I_C (R_C + R_E)$$

R_E provides excellent stabilization in this circuit.

$$V_2 = V_{BE} + I_C R_E$$

Suppose there is a rise in temperature, then the collector current I_C decreases, which causes the voltage drop across R_E to increase. As the voltage drop across R_2 is V_2 , which is independent of I_C , the value of V_{BE} decreases. The reduced value of I_B tends to restore I_C to the original value.

Stability Factor

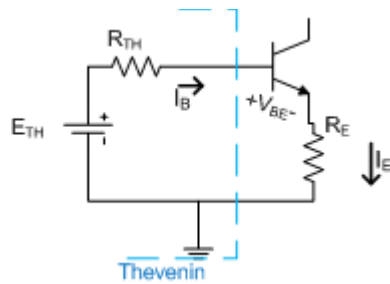

Apply KVL, $E_{TH} - I_B R_{TH} - V_{BE} - I_E R_E = 0$ ----(1)

We know that $I_E = I_C + I_B$, So, equation 1 become

$$E_{TH} - I_B R_{TH} - V_{BE} - (I_B + I_C) R_E = 0$$

Differentiate above equation with respect to I_C (take V_{BE} and E_{TH} as a constants).

$$0 - \frac{dI_B}{dI_C} R_{TH} - 0 - \frac{dI_B}{dI_C} R_E - R_E = 0$$

$$\frac{dI_B}{dI_C} = \frac{-R_E}{R_{TH} + R_E}$$

$$S = \frac{1 + \beta}{1 + \beta \frac{R_E}{R_{TH} + R_E}}$$

Advantages

- Q point is stable against variation in temperature and replacement of transistor

Disadvantages

- Analysis and design are complex
- More circuit components are required

6. TRANSISTOR AMPLIFIER & OSCILLATOR

6.1 Practical circuit of transistor amplifier

A practical circuit of transistor amplifier is common emitter configuration. The various circuit elements and their functions of voltage divider biasing circuit are described below

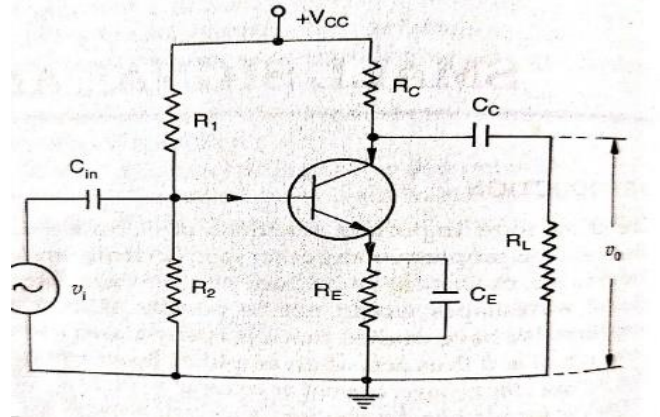

i) Biasing circuit

The resistors R_1 , R_2 and R_E form the biasing and stabilization circuit.

ii) The load R_L :

The resistance R_L connected at the output is known as load resistor. When a number of stages are used then R_L represents the input resistance of the next stage.

iii) Coupling capacitor C_c :

This capacitor couples the amplifier output to the load resistance or to the next stage of the amplifier. It is used for blocking the dc part and passing only the ac part of the amplified signal to the load.

iv) Input coupling capacitor C_{in} :

The input capacitor is used for coupling the ac input voltage V_i to the base of the transistor. As a capacitor blocks dc, this capacitor helps to block any dc component present in V_i and couples the ac component of the input signal.

v) Bypass capacitor C_E :

The capacitor connected in parallel with the emitter resistor R_E is called as the emitter bypass capacitor. This capacitor offers a low reactance to the amplified ac signal. Therefore, the emitter resistor R_E gets bypassed through C_E for only the ac signals. This will increase the voltage gain of the amplifier. Moreover, as C_E acts as an open circuit for dc voltages, it does not bypass R_E for dc conditions. Thus, presence of C_E does not alter the dc biasing conditions.

6.2 DC load line and DC equivalent circuit

When the transistor is given the bias and no signal is applied at its input, the load line drawn under such conditions is known as **DC load line**. Here there will be no amplification as the signal is absent.

Simply dc load line is a line on the output characteristics of a transistor which gives the value of V_{CE} and I_C corresponding to zero signal conditions.

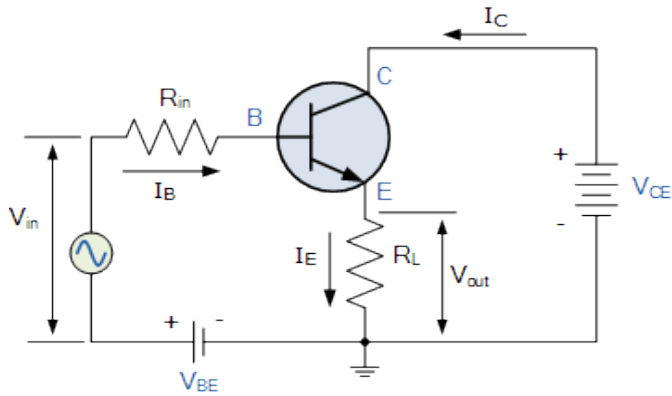

Applying kirchhoff's voltage law at the output section,we get

$$V_{CE} = V_{CC} - I_C R_C$$

Here V_{CC} , R_C are constant, therefore it represents a straight line known as load line.

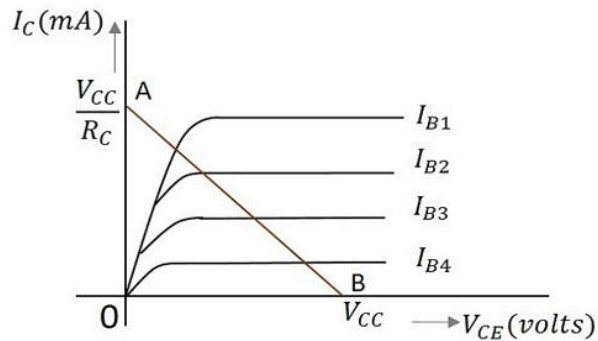

To obtain the load line, the two end points of the straight line are to be determined. Let those two points be A and B.

To obtain A

When collector emitter voltage $V_{CE} = 0$, the collector current is maximum and is equal to V_{CC}/R_C . This gives the maximum value of V_{CE} . This is shown as

$$V_{CE} = V_{CC} - I_C R_C$$

$$V_{CC} = I_C R_C$$

$$I_C = \frac{V_{CC}}{R_C}$$

This gives the point A ($OA = V_{CC}/R_C$) on collector current axis, shown in the above figure.

To obtain B

When the collector current $I_C = 0$, then collector emitter voltage is maximum and will be equal to the V_{CC} . This gives the maximum value of I_C . This is shown as

$$V_{CE} = V_{CC} - I_C R_C$$

$$V_{CE} = V_{CC}$$

This gives the point B, which means ($OB = V_{CC}$) on the collector emitter voltage axis shown in the above figure.

6.3 AC load line and AC equivalent circuit

When an input signal along with the DC voltages are applied, the load line drawn is called AC load line. Simply the AC load line is a line on the output characteristic of a transistor circuit which gives the value of V_{CE} and I_C when signal is applied.

For AC equivalent, V_{CC} is ground and all capacitor are short. So the circuit can be as follow

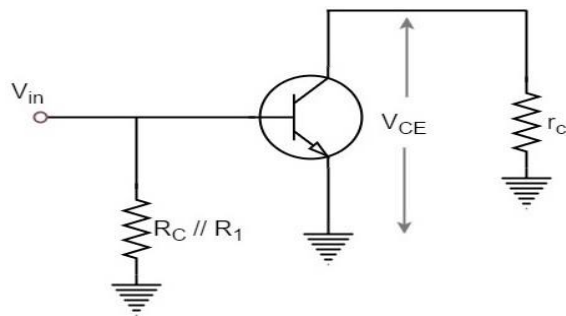

From the above figure,

$$V_{CE} = (R_C || R_L) \times I_C$$

$$r_c = R_C || R_L$$

From KVL at output side, we get $V_{ce} = -I_c r_{ac}$(1)

Here output contain both DC and AC components

$$\text{So, } V_{CE} = V_{CEQ} + V_{ce} \text{(2)}$$

$$I_C = I_{CQ} + i_c \text{(3)}$$

Put the value of equation (1) in equation 2

$$V_{CE} = V_{CEQ} - i_c r_{ac} \text{(4)}$$

Put the value of $i_c = I_C - I_{CQ}$ from eq(2) in eq(4)

$$V_{CE} = V_{CEQ} - (I_C - I_{CQ}) r_{ac} \text{(5)}$$

For maximum value of V_{CE} , I_C becomes zero

$$V_{CE} = V_{CEQ} + I_{CQ} r_{ac}$$

For maximum value of I_C , V_{CE} becomes zero

$$0 = V_{CEQ} - (I_C - I_{CQ}) r_{ac}$$

$$I_C = \frac{V_{CEQ}}{r_{ac}} + I_{CQ}$$

The following graph represents the AC load line which is drawn between saturation and cut off points.

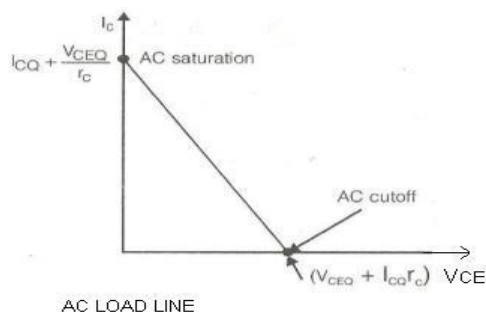

AC and DC Load Line

When AC and DC Load lines are represented in a graph, it can be understood that they are not identical. Both of these lines intersect at the **Q-point** or **quiescent point**. The endpoints of AC load line are saturation and cut off points. This is understood from the figure below.

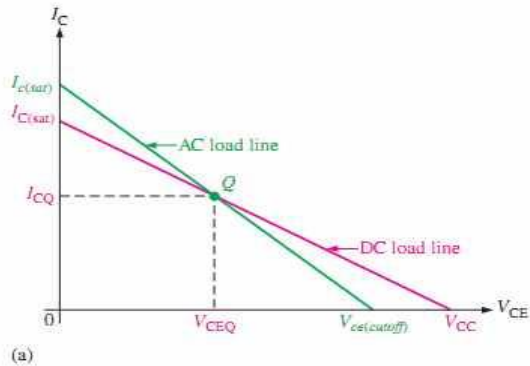

6.4 Calculation of gain

The graphical method is used to calculate the current gain and voltage gain of the amplifier. The output characteristics are shown in figure

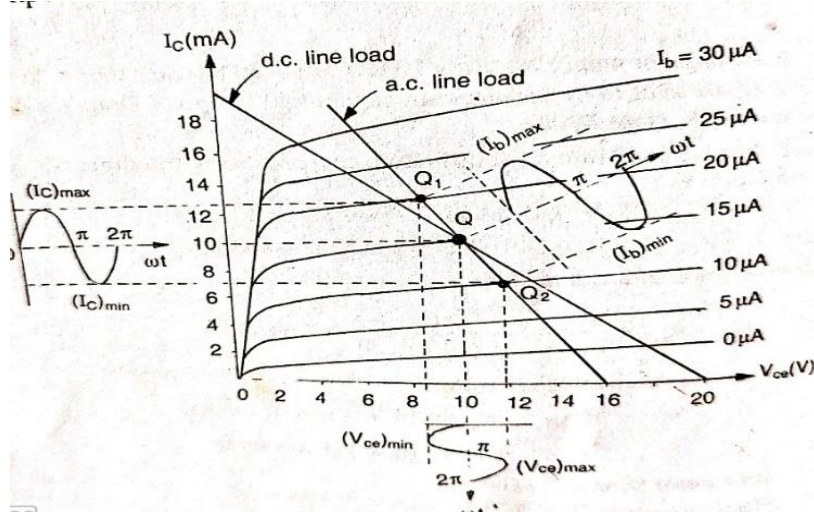

- The slope of dc load line is $\frac{1}{R_{DC}}$ while the slope of ac load line is $\frac{1}{R_{AC}}$. Here $R_{AC} = R_{DC} = R_L \parallel R_C$
- The operating point is the intersection of DC load line and the output characteristic. As Q point describes the zero signal condition and hence the ac load line also passes through point Q.
- When ac signal is applied, if there is variation in the base current. As a result, the operating point moves on ac load line between points Q_1 and Q_2 .
- The corresponding variations in collector current I_C and collector to emitter voltage V_{CE} are shown in figure.
- The collector current varies between $(I_C)_{max}$ and $(I_C)_{min}$ While the collector emitter voltage varies between $(V_{CE})_{max}$ and $(V_{CE})_{min}$
- The current gain and voltage gain of the amplifier are given as

$$\text{Current Gain} = \frac{(I_C)_{max} - (I_C)_{min}}{(I_B)_{max} - (I_B)_{min}}$$

$$\text{Voltage gain} = \frac{(V_{CE})_{max} - (V_{CE})_{min}}{(V_i)_{max} - (V_i)_{min}}$$

6.5 Phase reversal

- The phase difference of 180° between input voltage and output voltage in an amplifier is known as phase reversal.
- The common emitter transistor amplifier is the only configuration that gives an inversion, 180° , between the input and output signals.
- The reason for this can be seen from the fact that as the input voltage rises, so the current increases through the base circuit. In turn this increases the current through the collector circuit, i.e. it tends to turn the transistor on. This results in the voltage between the collector and emitter terminals falling.
- In this way an increase in voltage between the base and emitter has resulted in a fall in voltage between the collector and emitter terminals, in other words the phase of the two signals has been inverted.

6.6 H-parameters of transistors

- Every linear circuit having input and output terminals can be analyzed by four parameters. Since these parameters have mixed dimensions they are called as Hybrid Parameters.
- Characteristics of amplifier can be specified easily in terms of h-parameters and gives accurate results.
- We know that transistor is a three terminal device. If one terminal is made common to the input and output, then the transistor can be represented as a two-port network.
- For each port, there are two variables, currents and voltages. The standard directions of currents and polarities of voltages for a two-port network shown in fig below.

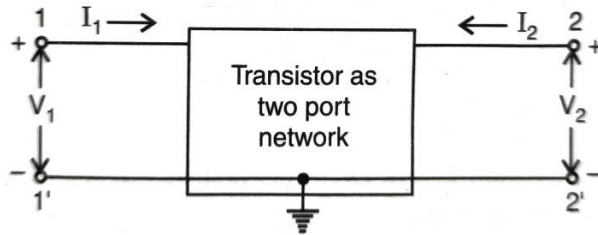

Here,

I_1 : input current, V_1 : input voltage

I_2 : output current, V_2 : output voltage

6.7 Simplified H-parameters of transistors

Transistor is a current operated device. Here input voltage and output current are dependent variable and input current and output voltage are independent variables.

$$V_1 = f_1(I_1, V_2) \dots \dots \dots (1)$$

$$I_2 = f_2(I_1, V_2) \dots \dots \dots (2)$$

The relationship between voltages and current in h parameters can be represented as:

$$V_1 = h_{11}I_1 + h_{12}V_2$$

$$I_2 = h_{21}I_1 + h_{22}V_2$$

The parameters h_{11} and h_{21} may be determined by short circuiting the output terminal of a given circuit. On the other hand, h_{12} and h_{22} may be determined by open circuiting the input terminals of the given circuit.

So

$$h_{11} = \frac{V_1}{I_1} = \text{Input Impedance with output short circuited and unit is ohm} = h_i$$

$$h_{12} = \frac{V_1}{V_2} = \text{Reverse Voltage gain with input open circuited and has no unit} = h_r$$

$h_{21} = \frac{I_2}{I_1}$ = Forward current gain with output short circuited and has no unit = h_f

$h_{22} = \frac{I_2}{V_2}$ = Output admittance with input open circuited and unit is mho = h_o

The equations of h parameter can also be written using alphabetic notations,
 $V_1 = h_i I_1 + h_r V_2$

$I_2 = h_f I_1 + h_o V_2$

From above, it is clear that all the four parameters have different unit and thus the parameters are hybrid (mixed) in nature. Therefore, they are called as hybrid or h-parameters.

6.8 Generalised approximate model

We know that,

$V_1 = h_i I_1 + h_r V_2$(1)

$I_2 = h_f I_1 + h_o V_2$(2)

Since, each term of equation (1) has the units of volts, we can use Kirchhoff's voltage law to find a circuit that fits this equation.

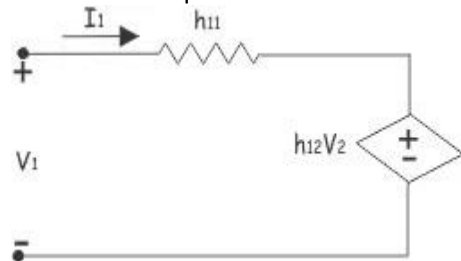

Similarly, each term of equation (2) has the units of current, we can use Kirchhoff's current law to find a circuit that fits this equation.

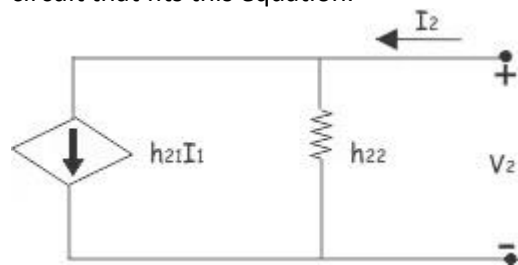

Combining these two figures, we get the general hybrid equivalent circuit as shown in the fig

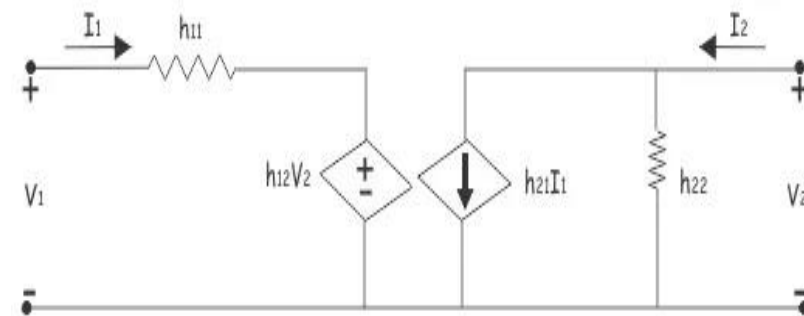

The h parameters equivalent network of a two port network

The h-parameter representation for transistor depends upon the type of configuration (CE, CB or CC). Therefore, each h-parameter is assigned a second subscript letter e, b or c depending upon the type of configuration.

The following table summarizes the h-parameters for all the three configurations

Parameter	CB	CE	CC
Input resistance	h_{ib}	h_{ie}	h_{ic}
Reverse voltage gain	h_{rb}	h_{re}	h_{rc}
Forward transfer current gain	h_{fb}	h_{fe}	h_{fc}
Output admittance	h_{ob}	h_{oe}	h_{oc}

Hybrid equivalent circuit for Common Emitter Configuration

$$V_{be} = h_{ie}I_b + h_{re}V_{ce}$$

$$I_c = h_{fe}I_b + h_{oe}V_{ce}$$

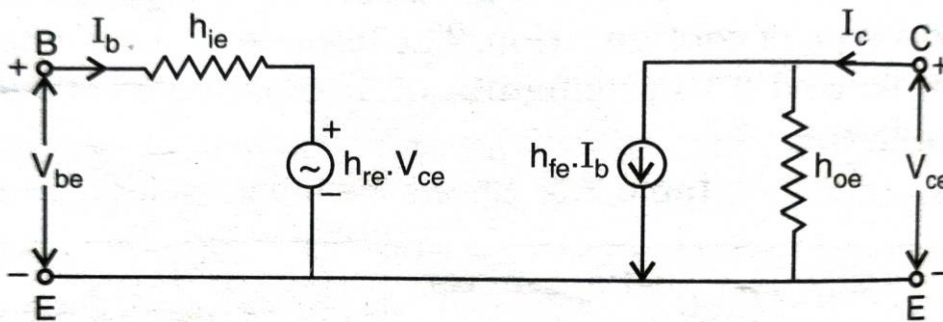

Hybrid equivalent circuit for Common Base Configuration

$$V_{eb} = h_{ib}I_e + h_{rb}V_{cb}$$

$$I_c = h_{fb}I_e + h_{ob}V_{cb}$$

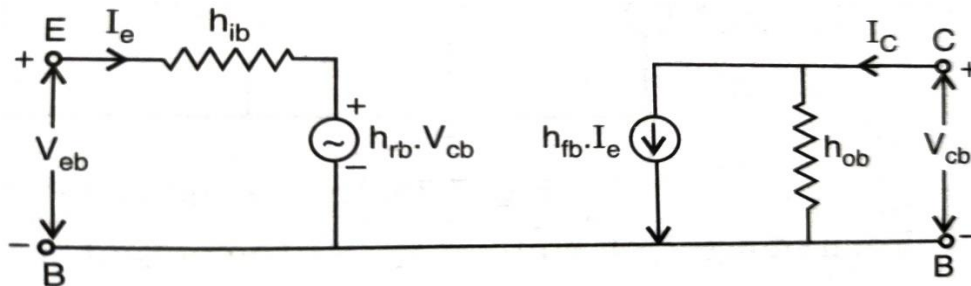

Hybrid equivalent circuit for Common Collector Configuration

$$V_{bc} = h_{ic}I_b + h_{rc}V_{ec}$$

$$I_e = h_{fc}I_b + h_{oc}V_{ec}$$

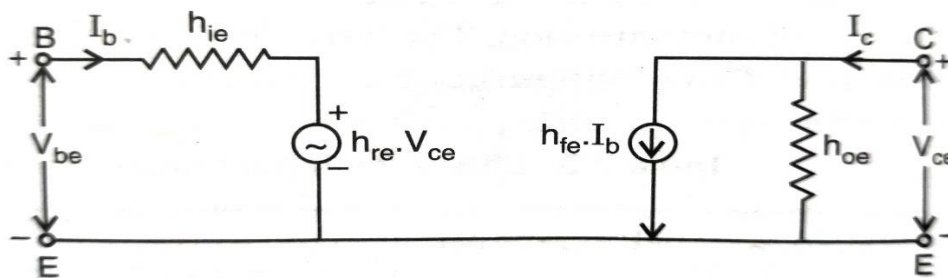

6.9 Analysis of CB, CE, CC amplifier using generalised approximate model

A transistor amplifier can be constructed by connecting an external load and signal source as indicated in figure below and biasing the transistor properly.

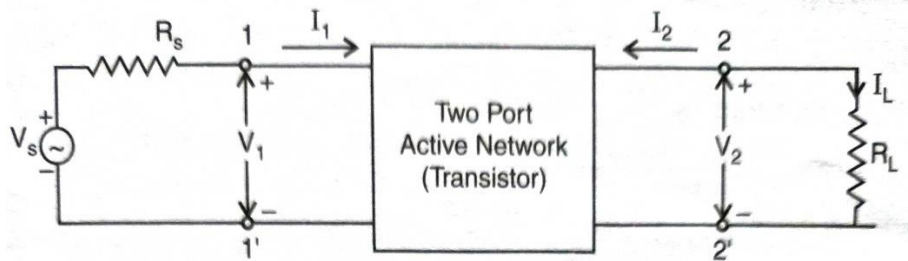

The hybrid model for above network is shown in fig below

The h-parameter equation is

$$V_1 = h_i I_1 + h_r V_2 \dots \dots \dots (1)$$

$$I_2 = h_f I_1 + h_o V_2 \dots \dots \dots (2)$$

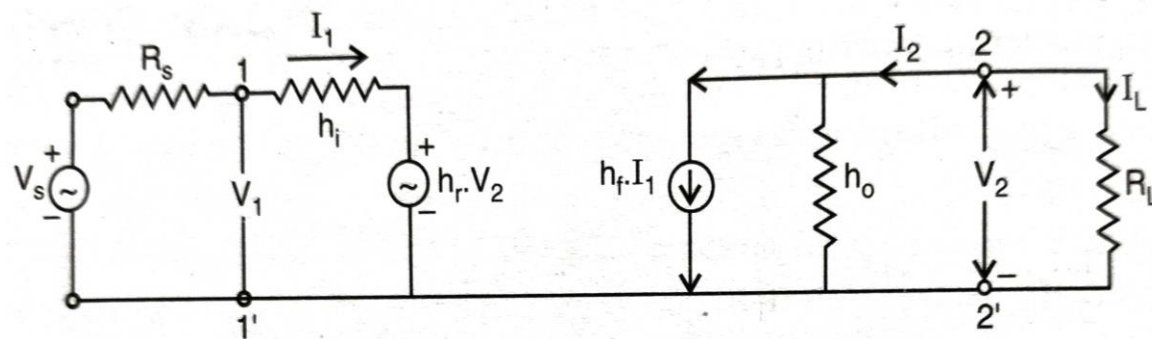

Current Gain

The current gain A_i for transistor amplifier is defined as the ratio of output to input currents.

$$A_i = \frac{I_L}{I_1} = \frac{-I_2}{I_1}$$

Voltage across the output terminal is

$$V_2 = I_L R_L = -I_2 R_L$$

Putting value V_2 of in eqn2

$$I_2 = h_f I_1 - h_o I_2 R_L$$

$$I_2 (1 + h_o R_L) = h_f I_1$$

$$\frac{I_2}{I_1} = \frac{h_f}{1 + h_o R_L}$$

$$A_i = \frac{h_f}{1 + h_o R_L}$$

Input Resistance R_i

The input resistance R_i is defined as the resistance we see looking into the amplifier input terminal.

Mathematically

$$R_i = \frac{V_1}{I_1}$$

Putting the value of $V_2 = -I_2 R_L$ in equation (1)

$$V_1 = h_i \cdot I_1 + h_r \cdot V_2 = h_i \cdot I_1 + h_r \cdot (-I_2 R_L) = h_i \cdot I_1 - h_r \cdot I_2 \cdot R_L$$

Dividing the above equation on the both sides by I_1 , we have

$$\frac{V_1}{I_1} = h_i - h_r \cdot \left(\frac{I_2}{I_1} \right) R_L$$

But
$$\frac{V_1}{I_1} = R_i$$

Therefore
$$R_i = h_i - h_r \cdot \left(\frac{I_2}{I_1} \right) \cdot R_L$$

We know that
$$A_i = \frac{-I_2}{I_1}$$

Thus,
$$R_i = h_i + h_r \cdot A_i \cdot R_L$$

Putting the value of $A_i = \frac{-h_f}{1 + h_o \cdot R_L}$ in last equation, we have

$$R_i = h_i + h_r \cdot \left(\frac{-h_f}{1 + h_o \cdot R_L} \right) \cdot R_L = h_i - \frac{h_r \cdot h_f}{h_o + \frac{1}{R_L}} = h_i - \frac{h_r \cdot h_f}{h_o + Y_L}$$

where $\frac{1}{R_L} = Y_L = \text{Load admittance}$.

Therefore, input resistance is a function of the load resistance.

Voltage Gain

The voltage gain is defined as the ratio of output voltage V_2 to input voltage V_1 .

$$A_v = \frac{V_2}{V_1} = -\frac{I_2 \cdot R_L}{V_1}$$

Since we know that
$$A_i = -\frac{I_2}{I_1} \quad \text{or} \quad I_2 = -A_i \cdot I_1$$

Therefore,
$$A_v = \frac{A_i \cdot I_1 \cdot R_L}{V_1} = A_i \cdot R_L \left(\frac{I_1}{V_1} \right)$$

But
$$\frac{V_1}{I_1} = R_i$$

$$A_v = \frac{A_i \cdot R_L}{R_i}$$

Again, since
$$A_i = \frac{-h_f}{1 + h_o \cdot R_L}$$

and
$$R_i = h_i - \frac{h_r \cdot h_f}{h_o + \frac{1}{R_L}}$$

Substitute the value of A_i & R_i in above equation

$$A_v = -\frac{h_f \cdot R_L}{h_i + (h_i \cdot h_o - h_r \cdot h_f) R_L}$$

Replacing

$$\Delta h = h_i h_o - h_r h_f$$

Hence,

$$A_v = -\frac{h_f \cdot R_L}{h_i + \Delta h \cdot R_L}$$

Output Resistance

The output resistance may be calculated by reducing the source voltage V_s to zero and load resistance R_L to infinity and driving the output terminals by a voltage generator V_2 .

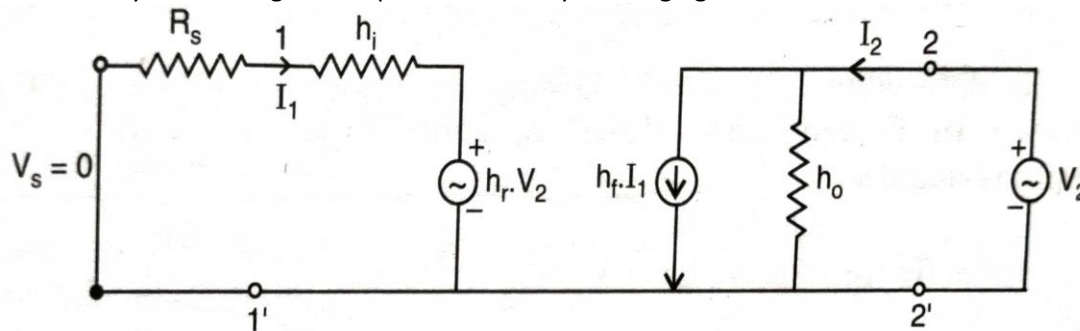

Mathematically,

$$R_0 = \frac{V_2}{I_2}$$

But

$$I_2 = h_f \cdot I_1 + h_o \cdot V_2$$

Hence

$$R_0 = \frac{V_2}{h_f \cdot I_1 + h_o \cdot V_2}$$

Applying KVL to the input side of the circuit, we have

$$R_s \cdot I_1 + h_r \cdot V_2 + h_i \cdot I_1 = 0$$

or

$$I_1 (R_s + h_i) = -h_r \cdot V_2$$

or

$$I_1 = -\frac{h_r \cdot V_2}{R_s + h_i}$$

$$R_0 = \frac{V_2}{h_f \cdot \left(\frac{-h_r \cdot V_2}{R_s + h_i} \right) + h_o \cdot V_2} = \frac{V_2}{\frac{-h_f \cdot h_r \cdot V_2}{R_s + h_i} + h_o \cdot V_2}$$

$$\text{Rearranging, we get } R_0 = \frac{R_s + h_i}{h_o \cdot (R_s + h_i) - h_f \cdot h_r} = \frac{R_s + h_i}{R_s \cdot h_o + (h_i h_o - h_f \cdot h_r)} = \frac{R_s + h_i}{R_s \cdot h_o + \Delta h}$$

where

$$\Delta h = h_i h_o - h_f h_r$$

If source resistance R_s is zero, then output resistance will be

$$R_0 = \frac{h_i}{\Delta h} \quad \dots$$

7.25. h-PARAMETER (HYBRID) EXPRESSION FOR COMMON-EMITTER AMPLIFIER

The h-parameter expressions for CE amplifier will be obtained with the help of general h-parameter formulas discussed in last article.

1. Current Gain : The general expression for current gain is

$$A_i = -\frac{h_f}{1 + h_o \cdot R_L} \quad \dots(7.37)$$

For common-emitter amplifier, we add an additional subscript 'e'.

Hence, current gain for CE Amplifier is given by

$$A_i = -\frac{h_{fe}}{1 + h_{oe} \cdot R_L} \quad \dots(7.38)$$

Here R_L is the a.c. load resistance

2. Input resistance : The resistance looking into the amplifier input terminals (base of a transistor) is

General expression
$$R_i = h_i - \frac{h_r \cdot h_f}{h_o + \frac{1}{R_L}} \quad \dots(7.39)$$

Based upon equation (7.39), expression for common emitter amplifier will be given by

$$R_i = h_{ie} - \frac{h_{re} \cdot h_{fe}}{h_{oe} + \frac{1}{R_L}} \quad \dots(7.40)$$

We know that input resistance of the amplifier stage, Z_i depends upon the type of biasing arrangement

As an example, for a fixed bias circuit, we have

$$Z_i = R_i \parallel R_B$$

If there is no biasing resistance

then

$$Z_i = R_i \quad \dots(7.41)$$

3. Voltage Gain : General Expression is expressed as

$$A_v = -\frac{h_f \cdot R_L}{h_i + \Delta h \cdot R_L} \quad \dots(7.42)$$

Hence, expression for common emitter amplifier will be given by

$$A_v = -\frac{h_{fe} \cdot R_L}{h_{ie} + \Delta h \cdot R_L} \quad \dots(7.43)$$

Here,

$$\Delta h = h_{ie} \cdot h_{oe} - h_{re} \cdot h_{fe}$$

4. Output resistance : The resistance looking into the amplifier output terminals is general expression

$$R_o = \frac{R_s + h_i}{R_s \cdot h_o + \Delta h} \quad \dots(7.44)$$

$$R_s = \text{Source Resistance}$$

$$\Delta h = h_{ie} \cdot h_{oe} - h_{re} \cdot h_{fe}$$

The output resistance of the amplifier stage will be

$$Z_o = R_o \parallel R_L \quad \dots(7.45)$$

7.26. h-PARAMETER (HYBRID) EXPRESSIONS FOR COMMON BASE AMPLIFIER

(i) Current Gain

General Expression
$$A_i = -\frac{h_f}{1 + h_o \cdot R_L} \quad \dots(7.49)$$

Hence, expression for common base amplifier will be

$$A_i = \frac{-h_{fb}}{1 + h_{ob} \cdot R_L} \quad \dots(7.50)$$

(ii) Input resistance:

The resistance looking into the input terminals is

general Expression
$$R_i = h_i - \frac{h_r \cdot h_f}{h_o + \frac{1}{R_L}} \quad \dots(7.51)$$

Hence, expression for common base amplifier will be

$$R_i = h_{ib} - \frac{h_{rb} \cdot h_{fb}}{h_{ob} + \frac{1}{R_L}} \quad \dots(7.52)$$

The input resistance of the amplifier stage depends upon the biasing arrangement. If there is no biasing resistance, then

$$Z_i = R_i \quad \dots(7.53)$$

(iii) Voltage gain

General Expression
$$A_v = -\frac{h_f \cdot R_L}{h_i + \Delta h \cdot R_L} \quad \dots(7.54)$$

Hence, expression for common base amplifier will be

$$A_v = -\frac{h_{fb} \cdot R_L}{h_{ib} + \Delta h \cdot R_L} \quad \dots(7.55)$$

(iv) Output resistance

The resistance looking into amplifier output terminals is

general expression
$$R_o = \frac{R_s + h_i}{R_s \cdot h_o + \Delta h} \quad \dots(7.56)$$

Hence, expression for common-base Amplifier will be

$$R_o = \frac{R_s + h_{ib}}{R_s \cdot h_{ob} + \Delta h} \quad \dots(7.57)$$

7.27. h-PARAMETER (HYBRID) EXPRESSION FOR COMMON COLLECTOR AMPLIFIER

(i) Current gain

General Expression $A_i = -\frac{h_f}{1 + h_o \cdot R_L} \dots(7.61)$

Therefore, expression for common collector amplifier will be

$$A_i = -\frac{h_{fc}}{1 + h_{oc} \cdot R_L} \dots(7.62)$$

(ii) Input resistance

The input resistance looking into the input terminals is

$$R_i = h_{ic} - \frac{h_{rc} \cdot h_{fc}}{h_{oc} + \frac{1}{R_L}} \dots(7.63)$$

The input resistance of the amplifier stage depends upon the biasing arrangement. If there is no biasing resistance, then

$$Z_i = R_i \dots(7.64)$$

(iii) Voltage Gain

$$A_v = \frac{A_i \cdot R_L}{R_i}$$

$$A_v = -\frac{h_{fc} \cdot R_L}{h_{ic} + \Delta h \cdot R_L}$$

(iv) Output resistance

$$R_o = \frac{R_s + h_{ic}}{R_s \cdot h_{oc} + \Delta h}$$

6.10 Multi stage transistor amplifier

In Multi-stage amplifiers, the output of first stage is coupled to the input of next stage using a coupling device. These coupling devices can usually be a capacitor or a transformer. This process of joining two amplifier stages using a coupling device can be called as **Cascading**.

The following figure shows a two-stage amplifier connected in cascade.

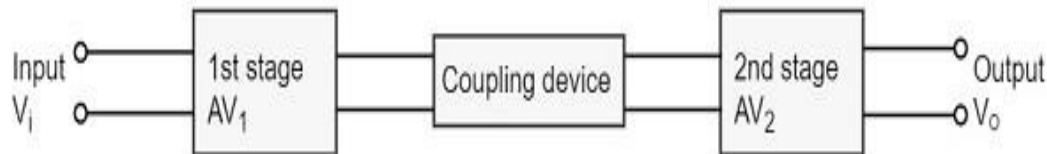

The overall gain is the product of voltage gain of individual stages.

$$A_v = A_{v1} \times A_{v2} = \frac{V_2}{V_1} \times \frac{V_0}{V_2}$$

Where A_v = Overall gain, A_{v1} = Voltage gain of 1st stage, and A_{v2} = Voltage gain of 2nd stage.

If there are n number of stages, the product of voltage gains of those n stages will be the overall gain of that multistage amplifier circuit.

Purpose of coupling device

The basic purposes of a coupling device are

- ✓ To transfer the AC from the output of one stage to the input of next stage.
- ✓ To block the DC to pass from the output of one stage to the input of next stage, which means to isolate the DC conditions.

Types of coupling used in amplifiers are

1. Resistance-Capacitance(RC) Coupling
2. Impedance Coupling
3. Transformer Coupling
4. Direct Coupling

6.10.1 R.C. coupled amplifier

- A **Resistance Capacitance (RC) Coupled Amplifier** is basically a multi-stage amplifier circuit extensively used in electronic circuits. Here the individual stages of the amplifier are connected together using a resistor-capacitor combination due to which it bears its name as RC Coupled.
- The constructional details of a two-stage RC coupled transistor amplifier consists of two transistors, connected in CE configuration and a common power supply V_{CC} is used.
- The potential divider network R_1 and R_2 and the resistor R_e form the biasing and stabilization network. The resistor R_L is used as a load impedance.
- The input capacitor C_{in} present at the initial stage of the amplifier, couples AC signal to the base of the transistor. The capacitor C_c is the coupling capacitor that connects two stages and prevents DC interference between the stages and controls the shift of operating point. The emitter by-pass capacitor C_e offers a low reactance path to the signal.

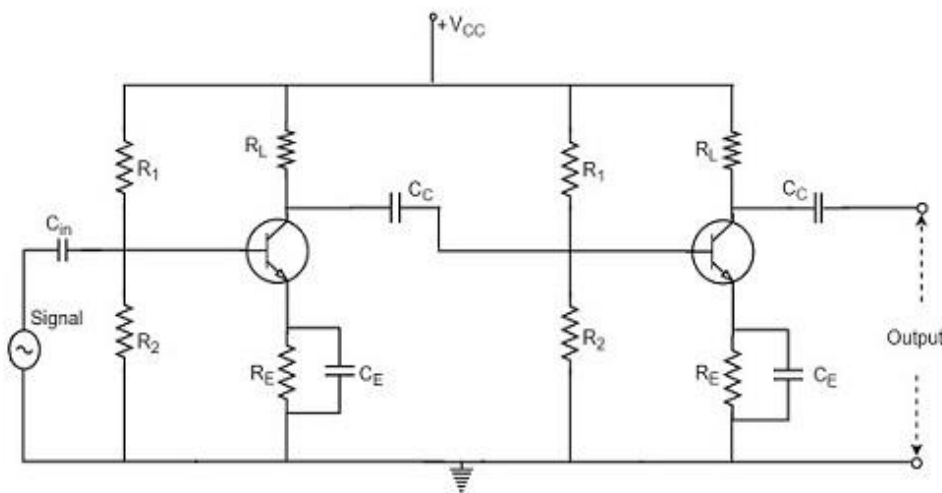

OPERATION OF RC COUPLED AMPLIFIER

- When an AC input signal is applied to the base of first transistor, it gets amplified and appears at the collector load R_L which is then passed through the coupling capacitor C_c to the next stage. This becomes the input of the next stage; whose amplified output again appears across its collector load. Thus the signal is amplified in stage by stage action.
- The important point that has to be noted here is that the total gain is less than the product of the gains of individual stages. This is because when a second stage is made to follow the first stage, the effective load resistance of the first stage is reduced due to the shunting effect of the input resistance of the second stage. Hence, in a multistage amplifier, only the gain of the last stage remains unchanged.
- As we consider a two stage amplifier here, the output phase is same as input. Because the phase reversal is done two times by the two stage CE configured amplifier circuit.

Frequency Response of RC Coupled Amplifier

Frequency response curve is a graph that indicates the relationship between voltage gain and function of frequency.

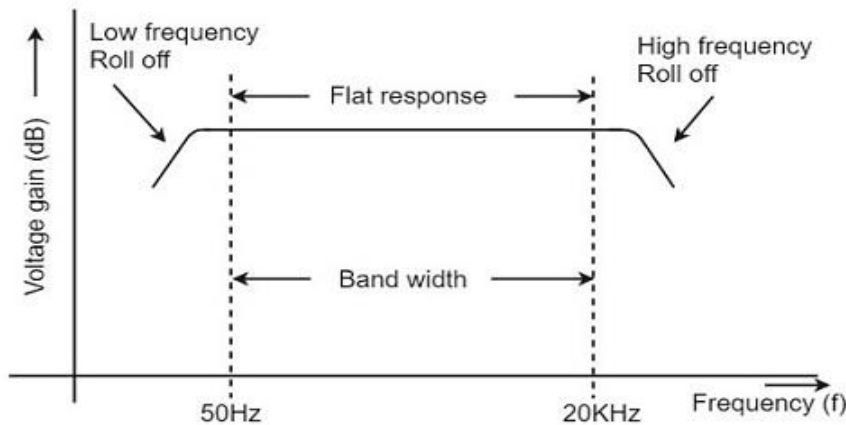

From the above graph, it is understood that the frequency rolls off or decreases for the frequencies below 50Hz and for the frequencies above 20 KHz. whereas the voltage gain for the range of frequencies between 50Hz and 20 KHz is constant.

We know that,

$$X_C = 1/2\pi fc$$

It means that the capacitive reactance is inversely proportional to the frequency.

At Low frequencies (i.e. below 50 Hz)

The capacitive reactance is inversely proportional to the frequency. At low frequencies, the reactance is quite high. The reactance of input capacitor C_{in} and the coupling capacitor C_C are so high that only small part of the input signal is allowed. The reactance of the emitter by pass capacitor C_E is also very high during low frequencies. Hence it cannot shunt the emitter resistance effectively. With all these factors, the voltage gain rolls off at low frequencies.

At High frequencies (i.e. above 20 KHz)

Again considering the same point, we know that the capacitive reactance is low at high frequencies. So, a capacitor behaves as a short circuit, at high frequencies. As a result of this, the loading effect of the next stage increases, which reduces the voltage gain. Along with this, as the capacitance of emitter diode decreases, it increases the base current of the transistor due to which the current gain (β) reduces. Hence the voltage gain rolls off at high frequencies.

At Mid-frequencies (i.e. 50 Hz to 20 KHz)

The voltage gain of the capacitors is maintained constant in this range of frequencies, as shown in figure. If the frequency increases, the reactance of the capacitor C_C decreases which tends to increase the gain. But this lower capacitance reactive increases the loading effect of the next stage by which there is a reduction in gain.

Due to these two factors, the gain is maintained constant.

ADVANTAGES OF RC COUPLED AMPLIFIER

- The frequency response of RC amplifier provides constant gain over a wide frequency range, hence most suitable for audio applications.
- The circuit is simple and has lower cost because it employs resistors and capacitors which are cheap.
- It becomes more compact with the upgrading technology.

DISADVANTAGES OF RC COUPLED AMPLIFIER

- The voltage and power gain are low because of the effective load resistance.
- They become noisy with age.
- Due to poor impedance matching, power transfer will be low.

APPLICATIONS OF RC COUPLED AMPLIFIER

- They have excellent audio fidelity over a wide range of frequency.
- Widely used as Voltage amplifiers
- Due to poor impedance matching, RC coupling is rarely used in the final stages.

6.10.2 Transformer coupled amplifier

- In multi-stage amplifier circuits, when the output of the first stage is connected to the input of the second stage in cascade through the transformer, then it is called a Transformer Coupled Amplifier. Here Transformer acts as a coupled amplifier.
- It is applicable when the load is low and mainly used for power amplification. The turn ratio of a transformer can be utilized for matching impedance with the load.

Construction of Transformer Coupled Amplifier

- The coupling transformer T1 is connected between the output of the first stage and the input of the second stage. The collector of the transistor in the first stage is connected to the primary winding of T1 while the secondary winding of T1 is between potential divider R1 and the transistor base in the second stage.
- Instead of [resistor](#) and capacitor, a transformer is used in a transformer-coupled amplifier circuit to achieve high voltage gain and efficiency. Similarly, multiple stages can be formed by the coupling of the transformer.

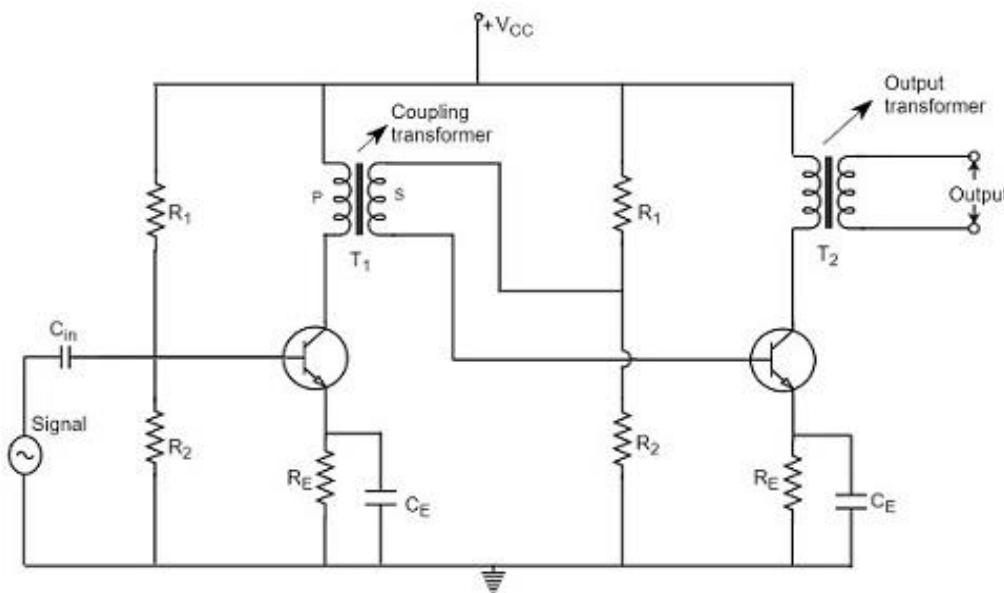

- R_1 , R_2 , and R_e are the potential dividers used for biasing and stabilization purposes.
- The low reactance path is provided by the by-pass capacitor C_e at the emitter junction of the second stage to the output signal of the first stage. Whereas the coupling capacitor C_c is used to connect these two stages by isolating DC interference from one stage to another stage and also controls the operation. The input capacitor C_{in} in the first stage allows the AC signal to the base of the transistor.

Operation of Transformer Coupled Amplifier

- The AC input signal applied in the first stage flows through the input capacitor to the base of the transistor by eliminating DC components in the signal. This input signal gets amplified by the transistor in the first stage and it is collected by the primary winding of the transformer T1. Here T1 transformer is used for coupling two stages.
- The signal, which is amplified in the first stage is fed to the input of the second stage through the secondary winding of T1.
- Due to the matching property of coupled transformer T1 like matching of impedance property, the low resistance of the load of one stage can be reflected as high load resistance to the previous stage.
- The voltage of the amplified signal at the primary winding can be converted in accordance with the turns ratio of the secondary winding of T1. This method provides better impedance matching properties, used for power amplification. The output of the coupling transformer can be referred to as the final output because of its impedance matching properties.

Frequency Response of Transformer Coupled Amplifier

- The frequency response of any electronic circuit indicates the gain i.e., how much of output we are getting for an input signal. Here, the frequency response of the transformer-coupled amplifier is shown in the following figure.

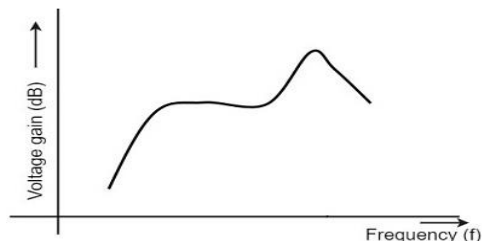

- It offers low-frequency response characteristics than the RC coupled amplifier. And also transformer-coupled amplifier offers constant gain over a small range of frequencies.
- At low frequencies, due to the reactance of the primary transformer T1, the gain is decreased. At higher frequencies, the capacitance between the turns of the transformer will act as a condenser and this reduces the output voltage and this leads to decrement in gain.

Advantages of Transformer Coupled Amplifier–

- An excellent impedance matching is provided.
- Gain achieved is higher.
- There will be no power loss in collector and base resistors.
- Efficient in operation.

Disadvantages of Transformer Coupled Amplifier

- Though the gain is high, it varies considerably with frequency. Hence a poor frequency response.
- Frequency distortion is higher.
- Transformers tend to produce hum noise.
- Transformers are bulky and costly.

Applications

- Mostly used for impedance matching purposes.
- Used for Power amplification.
- Used in applications where maximum power transfer is needed.

6.11 Feedback in amplifier

- The **feedback-amplifier** can be defined as an amplifier which has feedback lane that exists between output to input. The process by which **some part or fraction of output is combined with the input** is known as feedback.

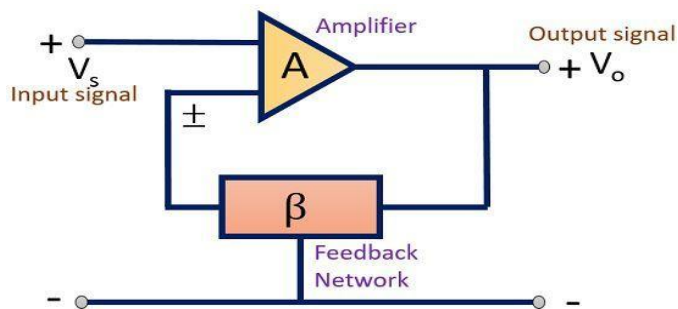

- A feedback amplifier generally consists of two parts. They are the amplifier and the feedback circuit. The feedback circuit usually consists of resistors. A feedback network is employed in an amplifier so as to control the gain and other factors of the device.
- There are two types of feedback in amplifiers. They are positive feedback, also called regenerative feedback, and negative feedback, also called degenerative feedback.
- Positive feedback occurs when the feedback signal is in phase with the input signal. Negative feedback occurs when the feedback signal is out of phase with the input signal.

6.11.1 General theory of feedback

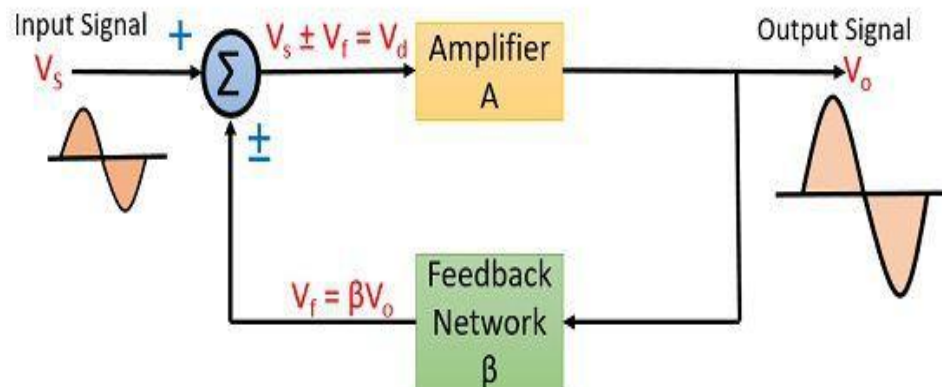

- An input signal V_s is applied to the amplifier with gain A , that produces an amplified signal, V_o .
- A portion or fraction of this V_o is then fed to a feedback network having gain β . The output of feedback network is V_f , this signal is then given to summer or a mixer that resultantly produces either **sum or difference** of the two signal depending on their phase relationship.
- The gain of an amplifier is given as the ratio of output voltage or current to the input voltage or current.

So for the above figure, the gain of the circuit without feedback is given as

$$A = \frac{V_o}{V_d} \dots\dots\dots(1)$$

The gain of feedback network is given as

$$\beta = \frac{V_f}{V_o} \dots\dots\dots(2)$$

But as we can see V_d is the mixer output voltage given by

$$V_d = V_s \pm V_f \dots\dots\dots(3)$$

From Eq 1 we can write as

$$V_o = AV_d \dots\dots\dots(4)$$

Substituting the value V_d in eq 4

$$V_o = A[V_s \pm V_f] \dots\dots\dots(5)$$

From Eq 2

$$V_f = \beta V_o \dots\dots\dots(6)$$

Substituting the value of V_f in eq 5

$$V_o = A [V_s \pm \beta V_o]$$

$$V_o = AV_s \pm A \beta V_o$$

$$V_o \mp A \beta V_o = AV_s$$

$$V_o [1 \mp A \beta] = AV_s$$

$$\frac{V_o}{V_s} = \frac{A}{1 \mp A \beta}$$

$$A_{vf} = \frac{A}{1 \mp A \beta}$$

6.11.2 Negative feedback circuit

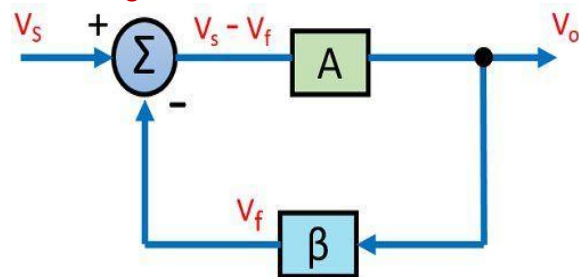

- The feedback in which the feedback energy i.e., either voltage or current is out of phase with the input and thus opposes it, is called as negative feedback.
- Here mixer circuit will resultantly **produce the difference** between the two signals.

- In negative feedback, the amplifier introduces a phase shift of 180° into the circuit while the feedback network is so designed that it produces no phase shift or zero phase shift. Thus the resultant feedback voltage V_f is 180° out of phase with the input signal V_{in} .
- So, in this case, the gain of the amplifier is given as

$$A_{vf} = \frac{A}{1 + A\beta}$$

- For a **negative feedback**, the value of denominator is always greater than 1, this will **decrease the overall gain** of the system by the factor $1 + A\beta$.

6.11.3 Advantage of negative feedback

- Stability of gain is improved
- Reduction in distortion
- Reduction in noise
- Increase in input impedance
- Decrease in output impedance
- Increase in the range of uniform application

It is because of these advantages negative feedback is frequently employed in amplifiers.

6.12 Power amplifier and its classification

- A power amplifier is an electronic amplifier designed to increase the magnitude of power of a given input signal. The power of the input signal is increased to a level high enough to drive loads of output devices like speakers, headphones, RF transmitters etc.

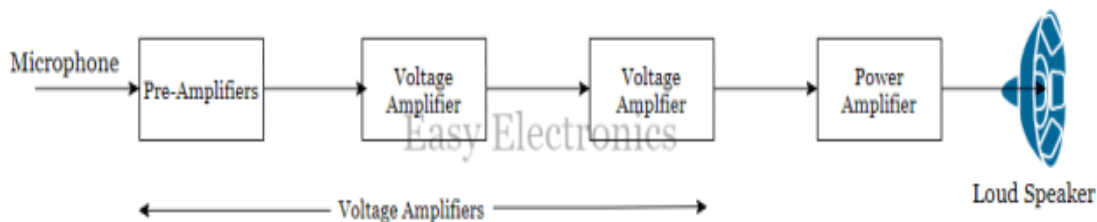

Simplified Block Diagram of Power Amplifier System

- The classification is done based on their frequencies and also based on their mode of operation.

Classification Based on Frequencies

Power amplifiers are divided into two categories, based on the frequencies they handle. They are as follows.

- **Audio Power Amplifiers** – The audio power amplifiers raise the power level of signals that have audio frequency range (20 Hz to 20 KHz). They are also known as Small signal power amplifiers.
- **Radio Power Amplifiers** – Radio Power Amplifiers or tuned power amplifiers raise the power level of signals that have radio frequency range (3 KHz to 300 GHz). They are also known as large signal power amplifiers.

Classification Based on Mode of Operation

On the basis of the mode of operation, i.e., the portion of the input cycle during which collector current flows, the power amplifiers may be classified as follows.

- **Class A Power amplifier** – When the collector current flows at all times during the full cycle of signal, the power amplifier is known as class A power amplifier.
- **Class B Power amplifier** – When the collector current flows only during the positive half cycle of the input signal, the power amplifier is known as class B power amplifier.
- **Class C Power amplifier** – When the collector current flows for less than half cycle of the input signal, the power amplifier is known as class C power amplifier.
- **Class AB Power amplifier** – It is the combination of class A and class B amplifiers so as to utilize the advantages of both.

6.12.1 Difference between voltage amplifier and power amplifier

BASIS OF COMPARISON	VOLTAGE AMPLIFIER	POWER AMPLIFIER
Use	The voltage amplifier amplifies the voltage or increases the voltage level of a signal.	The power amplifier amplifies the power of a signal.
Functionality	The voltage amplifier can work with low magnitude signal.	The power amplifier can work with high magnitude signal.
Amplitude Of AC Signal	In voltage amplifier, the amplitude of input A.C signal is small.	In power amplifier the amplitude of input A.C signal is large.
Transistor	The transistor used in the voltage amplifier has a thin base because it does not handle large current.	The transistor used in the power amplifier has a thick base because it handles the very large current.
Output Impedance	The output impedance of the voltage amplifier is very high, about 12 kilo-ohm.	The output impedance of the power amplifier is very low, up to 200 ohm, so that it can deliver a high current.
Collector Current	The collector current of the voltage amplifier is very low up to 1 mA.	The collector current of the power amplifier is high greater than 100 mA.
Transistor Heat Dissipation	The transistor used can dissipate less heat produced during its operation.	The transistor used can dissipate more heat produced as compared to voltage amplifier during its operation.
Size Of Transistor	The physical size of transistor used is usually small and is known as low or medium power transistor.	The physical size of transistor used is usually large and is known as power transistor.
Collector Load	In power amplifier, the collector load has low resistance, typically 5Ω to 20Ω.	In voltage amplifier, the collector load has high resistance, typically 4Ω to 10kΩ.
Coupling	RC coupling is used in voltage amplifier.	Transformer coupling is used in power amplifier.
Application	Voltage amplifier is used for small signal voltage.	Power amplifier is used for high voltage signals.
Current Gain	The current gain of the power amplifier is very small.	The current gain of the power amplifier is very high.

6.12.2 Transformer coupled class A power amplifier

TRANSFORMER COUPLED CLASS A POWER AMPLIFIER

- The class A power amplifier is the circuit in which the output current flows for the entire cycle of the AC input supply. It has low output power and efficiency. In order to minimize those effects, the transformer coupled class A power amplifier has been introduced.
- The construction of transformer coupled class A power amplifier can be understood with the help of below figure. This is similar to the normal amplifier circuit but connected with a transformer in the collector load.

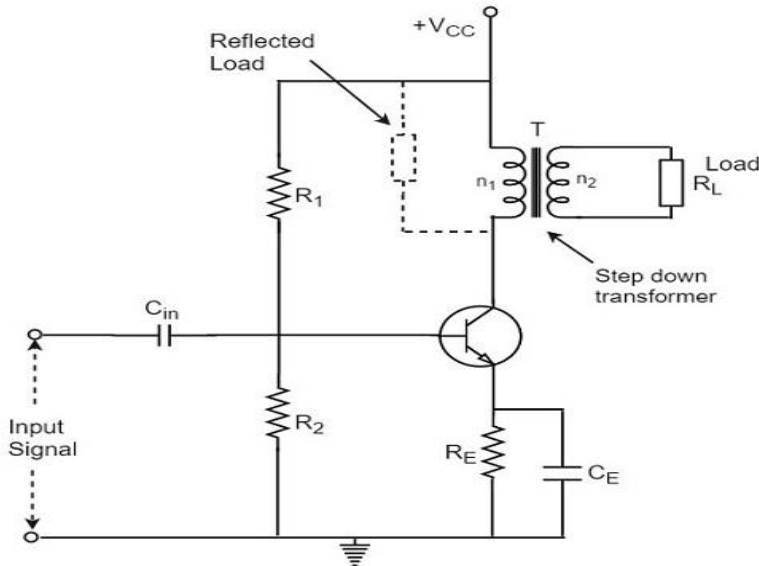

- Here R_1 and R_2 provide potential divider arrangement. The resistor R_E provides stabilization, C_E is the bypass capacitor and R_E to prevent a.c. voltage. The transformer used here is a step-down transformer.
- The high impedance primary of the transformer is connected to the high impedance collector circuit. The low impedance secondary is connected to the load (generally loud speaker).

Transformer Action

The transformer used in the collector circuit is for impedance matching. R_L is the load connected in the secondary of a transformer. R_L' is the reflected load in the primary of the transformer.

The number of turns in the primary are n_1 and the secondary are n_2 . Let V_1 and V_2 be the primary and secondary voltages and I_1 and I_2 be the primary and secondary currents respectively. The below figure shows the transformer clearly.

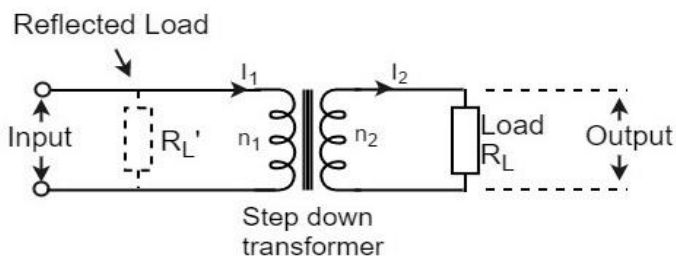

We know that $\frac{V_1}{V_2} = \frac{n_1}{n_2}$ and $\frac{I_1}{I_2} = \frac{n_2}{n_1}$

Or

$$V_1 = \frac{n_1}{n_2} \cdot V_2 \text{ and } I_1 = \frac{n_2}{n_1} \cdot I_2$$

$$\text{Hence, } \frac{V_1}{I_1} = \left(\frac{n_1}{n_2}\right)^2 \frac{V_2}{I_2}$$

But $\frac{V_1}{I_1} = R_L' = \text{effective input resistance}$

And $\frac{V_2}{I_2} = R_L = \text{effective output resistance}$

$$\text{Therefore, } R_L' = \left(\frac{n_1}{n_2}\right)^2 R_L = n^2 R_L$$

Where $n = \frac{\text{number of turns in primary}}{\text{number of turns in secondary}} = \frac{n_1}{n_2}$

A power amplifier may be matched by taking proper turn ratio in step down transformer.

Efficiency

- If the peak value of the collector current due to signal is equal to zero signal collector current, then the maximum a.c. power output is obtained.
- So, in order to achieve complete amplification, the operating point should lie at the center of the load line.
- The operating point obviously varies when the signal is applied. The collector voltage varies in opposite phase to the collector current.
- The input power under dc condition will be

$$(P_{in})_{dc} = (P_{tr})_{dc} = V_{cc} \cdot I_{CQ}$$

$$\text{Here } (P_0)_{ac} = \frac{V_{cc} \cdot I_{CQ}}{2}$$

$$\text{Therefore collector efficiency, } \frac{(P_0)_{ac}}{(P_{in})_{dc}} = \frac{V_{cc} \cdot I_{CQ}}{2 \cdot V_{cc} \cdot I_{CQ}} = \frac{1}{2} = 50\%$$

- The efficiency of a class A power amplifier is nearly 30% where as it has got improved to 50% by using the transformer coupled class A power amplifier.

Advantages

- ✓ No loss of signal power in the base or collector resistors.
- ✓ Excellent impedance matching is achieved.
- ✓ Gain is high.
- ✓ DC isolation is provided.

Disadvantages

- ✓ Low frequency signals are less amplified comparatively.
- ✓ Hum noise is introduced by transformers.
- ✓ Transformers are bulky and costly.
- ✓ Poor frequency response.

Applications

- ✓ This circuit is used where impedance matching is the main criterion.
- ✓ These are used as driver amplifiers and sometimes as output amplifiers.

6.12.3 Class A push – pull amplifier

CLASS A PUSH PULL AMPLIFIER

A push pull amplifier is an amplifier which has an output stage that can drive a current in either direction through the load. The output stage of a typical push pull amplifier consists of two identical BJTs or MOSFETs one sourcing current through the load while the other one sinking the current from the load.

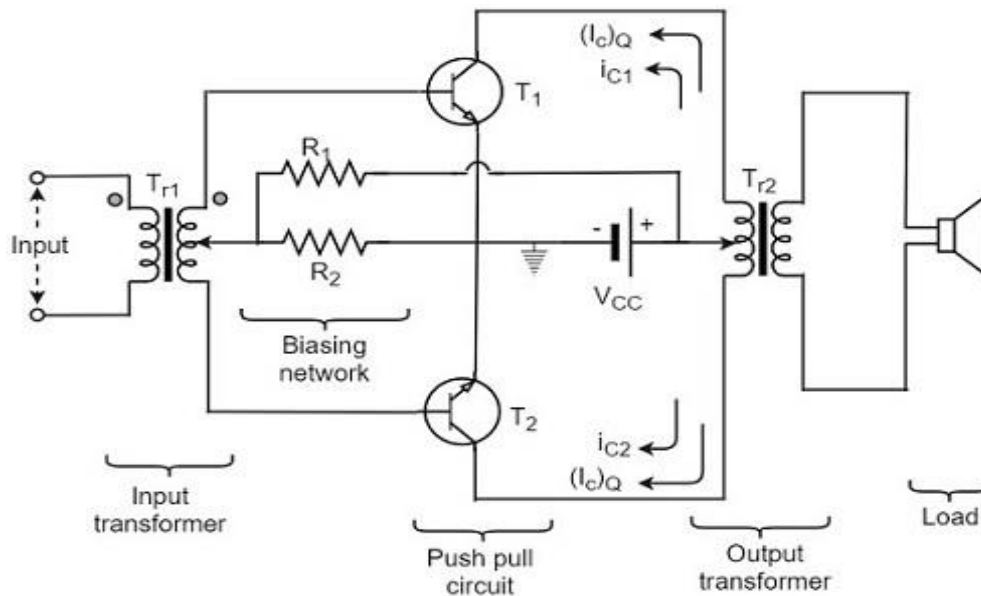

Construction

- In Push-pull arrangement, the two identical transistors T_1 and T_2 have their emitter terminals shorted.
- The input signal is applied to the transistors through the transformer T_{r1} which provides opposite polarity signals to both the transistor bases.
- The collectors of both the transistors are connected to the primary of output transformer T_{r2} .
- Both the transformers are center tapped. The V_{CC} supply is provided to the collectors of both the transistors through the primary of the output transformer.
- The resistors R_1 and R_2 provide the biasing arrangement. The load is generally a loudspeaker which is connected across the secondary of the output transformer. The turns ratio of the output transformer is chosen in such a way that the load is well matched with the output impedance of the transistor. So maximum power is delivered to the load by the amplifier.

Circuit Operation

- The output is collected from the output transformer T_{r2} . The primary of this transformer T_{r2} has practically no dc component through it.

- The transistors T_1 and T_2 have their collectors connected to the primary of transformer T_{r2} so that their currents are equal in magnitude and flow in opposite directions through the primary of transformer T_{r2} .
- When the a.c. input signal is applied, the base of transistor T_1 is more positive while the base of transistor T_2 is less positive. Hence the collector current i_{c1} of transistor T_1 increases while the collector current i_{c2} of transistor T_2 decreases.
- These currents flow in opposite directions in two halves of the primary of output transformer. Moreover, the flux produced by these currents will also be in opposite directions.
- Hence, the voltage across the load will be induced voltage whose magnitude will be proportional to the difference of collector currents
- Similarly, for the negative input signal, the collector current i_{c2} will be more than i_{c1} . In this case, the voltage developed across the load will again be due to the difference of current. The polarity of voltage induced across load will be reversed.
- The overall operation results in an a.c. voltage induced in the secondary of output transformer and hence a.c. power is delivered to that load.
- It is understood that, during any given half cycle of input signal, one transistor is being driven (or pushed) deep into conduction while the other being non-conducting (pulled out). Hence the name **Push-pull amplifier**. The harmonic distortion in Push-pull amplifier is minimized such that all the even harmonics are eliminated.

Advantages

- High a.c. output is obtained.
- The output is free from even harmonics.
- The effect of ripple voltages is balanced out. These are present in the power supply due to inadequate filtering.

Disadvantages

- The transistors are to be identical, to produce equal amplification.
- Center-tapping is required for the transformers.
- The transformers are bulky and costly.

6.12.4 Class B push – pull amplifier

CLASS B PUSH-PULL AMPLIFIER

- In class B amplifier, transistor conduct current for only one half of the input signal. A push pull amplifier is an amplifier which has an output stage that can drive a current in either direction through the load.
- The output stage of a typical push pull amplifier consists of two identical BJTs or MOSFETs one sourcing current through the load while the other one sinking the current from the load.

Construction

- The circuit of a push-pull class B power amplifier consists of two identical transistors T_1 and T_2 whose bases are connected to the secondary of the center-tapped input transformer T_{r1} . The emitters are shorted and the collectors are given the V_{CC} supply through the primary of the output transformer T_{r2} .

- The circuit arrangement of class B push-pull amplifier, is same as that of class A push-pull amplifier except that the transistors are biased at cut off, instead of using the biasing resistors. The figure below gives the detailing of the construction of a push-pull class B power amplifier.

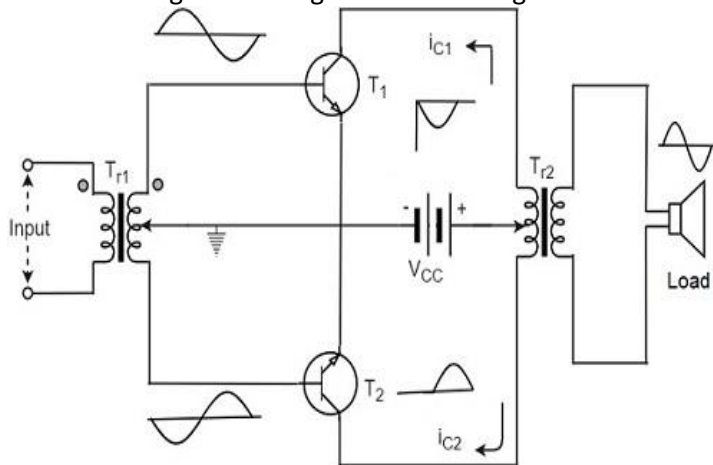

Operation

- The circuit of class B push-pull amplifier shown in the above figure clears that both the transformers are center-tapped. When no signal is applied at the input, the transistors T_1 and T_2 are in cut off condition and hence no collector currents flow. As no current is drawn from V_{CC} , no power is wasted.
- When input signal is given, it is applied to the input transformer T_{r1} which splits the signal into two signals that are 180° out of phase with each other. These two signals are given to the two identical transistors T_1 and T_2 .
- For the positive half cycle, the base of the transistor T_1 becomes positive and collector current flows. At the same time, the transistor T_2 has negative half cycle, which throws the transistor T_2 into cutoff condition and hence no collector current flows.
- For the next half cycle, the transistor T_1 gets into cut off condition and the transistor T_2 gets into conduction, to contribute the output.
- Hence for both the cycles, each transistor conducts alternately. The output transformer T_{r2} serves to join the two currents producing an almost undistorted output waveform.

Efficiency

The current in each transistor is the average value of half sine loop.

For half sine loop, I_{dc} is given by,
$$I_{dc} = \frac{(IC)_{max}}{\pi}$$

Therefore, $(P_{in})_{dc} = 2 \times \left[\frac{(IC)_{max}}{\pi} \times V_{CC} \right]$

Here factor 2 is introduced as there are two transistors in push-pull amplifier.

R.M.S. value of collector current =
$$\frac{(IC)_{max}}{\sqrt{2}}$$

R.M.S. value of output voltage =
$$\frac{V_{CC}}{\sqrt{2}}$$

Under ideal conditions of maximum power

Therefore,
$$(P_O)_{ac} = \frac{(IC)_{max}}{\sqrt{2}} \cdot \frac{V_{CC}}{\sqrt{2}} = \frac{(IC)_{max} \cdot V_{CC}}{2}$$

Now overall maximum efficiency

$$\eta = \frac{(P_O)_{ac}}{(P_{in})}$$
$$= \frac{(I_C)_{max} \cdot V_{CC}}{2} \cdot \frac{\pi}{2 \cdot (I_C)_{max} \cdot V_{CC}}$$

Overall Efficiency (η) = 0.785 = 78.5% = $\pi/4 = 0.785 = 78.5\%$

Hence the class B push-pull amplifier improves the efficiency than the class A push-pull amplifier.

Advantages

- The efficiency of a class-B push-pull amplifier is much higher than class-A amplifier.
- The use of push-pull system in the class-B amplifier eliminates even order harmonics in A.C. output signal.
- There is no D.C. component in the output signal.

Disadvantages

- Harmonic distortion is high.
- Self-bias is not used.

6.13 Oscillators

OSCILLATORS

- An oscillator is a device, which produces an output signal without any input signal of any desired frequency.
- It keeps producing an output signal, so long as the dc power is supplied.
- It simply converts unidirectional current drawn from a dc source of supply into alternating current of desired frequency. Therefore, sometimes called an inverter.

Block Diagram of an Oscillator

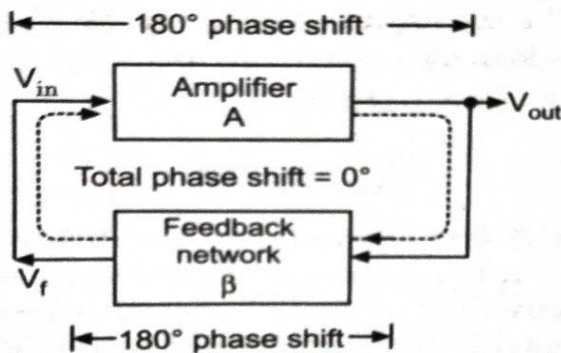

- An Oscillator consists of an amplifier and a phase shifting network. The amplifier receives the output of the phase shifting network. The amplifier then amplifies it, phase shifts through 180° and applies it to the input of the phase shifting network.
- The phase shifting network shifts the amplifier output through another 180° and attenuates it before applying it back to the amplifier input.
- Due to total phase shift of 360° , the feedback becomes a positive feedback, which give rise to the oscillations, if the Barkhausen Criterion is satisfied.

6.13.1 Types of oscillators

The electronic oscillator can be broadly classified into the following two categories:

1. Sinusoidal or Harmonic Oscillators

The oscillators which provide an output having a sine waveform known as sinusoidal or harmonic oscillators

2. Non-Sinusoidal or Relaxation Oscillators

The oscillators which provides an output having a square, rectangular or saw tooth waveform are known as non-sinusoidal or relaxation oscillator.

The sinusoidal oscillator can be further sub divided into the following types:

i) Tuned Circuit Oscillator

- These oscillators use a tuned circuit consisting of inductors (L) and capacitors (C) and are used to generate high frequency signals. Hence they are also known as radio frequency (R.F) oscillator.
- Such oscillators are Hartley, Colpitt, clap oscillator.

ii) RC Oscillators

- These oscillators use resistors and capacitors. RC oscillators are used to generate low or audio frequency signal. Thus they are also known as audio frequency (A.F) oscillators.
- Such oscillators are Phase shift and Wien bridge oscillator.

iii) Crystal Oscillator

- These oscillator use quartz crystals and are used to generate highly stabilized output signal with frequency up to 10 MHz
- The pierce oscillator is an example of crystal oscillator

iv) Negative Resistance Oscillators

- These oscillators use negative resistance characteristic of the devices such as tunnel diodes.
- A tunnel diode oscillator is an example of negative resistance oscillator.

6.13.2 Essentials of transistor oscillator

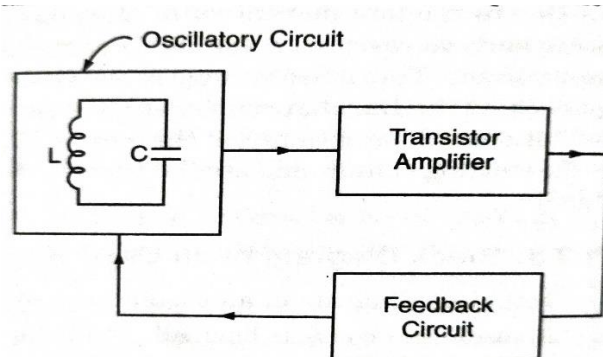

The transistor oscillator has following essential parts

i) Tank Circuit

- The tank circuit consists of an inductor L connected in parallel with capacitor C.
- It is known as frequency determining network. The frequency of oscillation in the circuit depends upon the values of inductance and capacitance.

ii) Transistor Amplifier

- The function of the amplifier is to amplify the oscillations produced by LC circuit.
- The amplifier receives dc power from battery and converts it into ac power for supplying to the tank circuit.

- The oscillation produced in tank circuit are applied to the input of the transistor. The transistor increases the output of these oscillations.

iii) Feedback Circuit

- The function of feedback circuit is to transfer a part of the output energy to LC circuit in proper phase.
- When the feedback is positive, the overall gain of the amplifier is

$$A_f = \frac{A}{1 - A\beta}$$

Where $A\beta$ is feedback factor or loop gain.

- If $A\beta=1$, $A_f = \infty$. Thus the gain becomes infinity i.e. there is output without any input. In another words, the amplifier works as oscillator.
- The condition $A\beta=1$ is known as **Barkhausen criterion** of oscillation.

6.13.3 Principle of operation of tuned collector, Hartley, colpitt, phase shift, weinbridge oscillator (no mathematical derivations)

TUNED COLLECTOR OSCILLATOR

- The tuned collector oscillator is one kind of transistor LC oscillator where the tank circuit comprises of a capacitor and a transformer, that is connected to the collector terminal of the transistor.
- R_1 and R_2 form the voltage divider bias for the transistor. R_e refers to the emitter resistor and is there to provide thermal stability.
- C_e is used to bypass the amplified ac oscillations and is the emitter bypass capacitor. C_2 is the bypass capacitor for resistor R_2 .
- The primary of the transformer, L_1 along with capacitor C_1 forms the tank circuit
- Transistor causes a phase shift of 180 degrees when it amplifies an input voltage. The transformer helps in giving a positive feedback

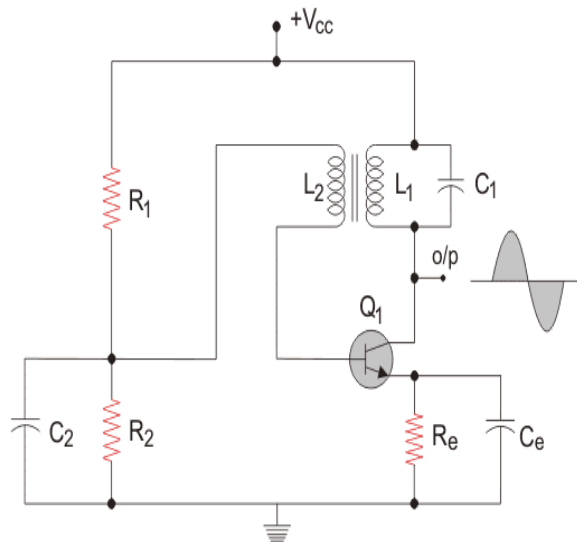

Working Principle

- When the power supply is turned ON, the transistor gets the current and starts conducting. The 'C1' capacitor starts charging. When the C1 capacitor gets fully charge, then starts discharging through the primary coil L1 of the transformer.
- The energy stored in the capacitor in the form of electrostatic energy gets converted to electromagnetic energy and gets stored in the inductor L_1 . Once the capacitor discharges

completely, the inductor starts [charging the capacitor](#) again. This charging & discharging sets up a sequence of oscillations in the tank circuit.

- These oscillations induce some voltage in the secondary winding L_2 by mutual induction which causes corresponding variations in the base current.
- The frequency of voltage induced in the secondary winding is same as that of the tank circuit and its magnitude depends upon the number of turns in secondary winding and coupling between both the windings.
- The voltage across L_2 is applied between base and emitter and appears in the amplified form in the collector circuit, thus overcoming the losses in the tank circuit. The number of turns of L_2 and coupling between L_1 and L_2 are so adjusted that oscillations across L_2 are amplified to a level just sufficient to supply losses to the tank circuit.
- The transformer introduces a phase shift of 180 degrees and the transistor also introduces a phase shift of 180 degrees too. So in total, we get a 360-degree phase shift and this is fed back to the tank circuit. It is an extremely required condition for positive feedback and continued oscillations. The frequency of oscillation depends on the value of the inductor and capacitor used in the tank circuit and is given by:

$$F = \frac{1}{2\pi\sqrt{(L_1 C_1)}}$$

Where,

F = Frequency of the oscillation.

L_1 = value of the inductance of primary of the transformer L_1 .

C_1 = value of capacitance of capacitor C_1 .

HARTLEY OSCILLATOR

- Hartley [oscillator](#) is a type of LC oscillator that generates undamped sinusoidal oscillations whose tank circuit consists of 2 inductors and a capacitor.
- Its frequency of oscillation is decided by its tank circuit which has a capacitors connected in parallel with the two serially connected inductors.
- These are used to produce the waves in the range of radio frequency and hence are also referred to as RF Oscillators.
- Here the R_C is the collector resistor while the emitter resistor R_E forms the stabilizing network. Further the resistors R_1 and R_2 form the voltage divider bias network for the transistor in common-emitter CE configuration.
- The capacitors C_i and C_o are the input and output coupling capacitors while the emitter capacitor C_E is the bypass capacitor used to bypass the amplified AC signals.

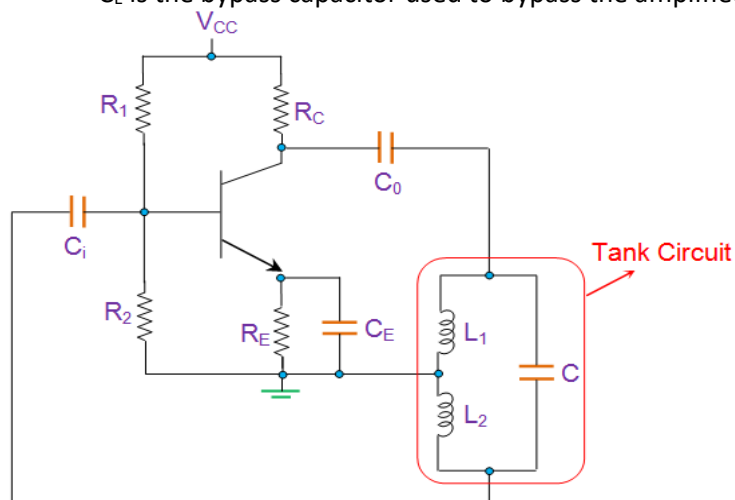

Working Principle

- On switching ON the power supply, the transistor starts to conduct, leading to an increase in the collector current, I_C which charges the capacitor C. On acquiring the maximum charge feasible, C starts to discharge via the inductors L_1 and L_2 .
- This charging and discharging cycles result in the damped oscillations in the tank circuit.
- The oscillation current in the tank circuit produces an AC voltage across the inductors L_1 and L_2 which are out of phase by 180° as their point of contact is grounded.
- The output of the amplifier is applied across the inductor L_1 while the feedback voltage drawn across L_2 is applied to the base of the transistor.
- The output of the amplifier is in-phase with the tank circuit's voltage and supplies back the energy lost by it while the energy fed back to amplifier circuit will be out-of-phase by 180° .
- The feedback voltage which is already 180° out-of-phase with the transistor is provided by an additional 180° phase-shift due to the transistor action.
- Hence the signal which appears at the transistor's output will be amplified and will have a net phase-shift of 360° .
- The frequency of such an oscillator is given as

$$F = \frac{1}{2\pi\sqrt{L_{eff}C}}$$

Where,

L_{eff} is the effective series inductance which is expressed as

$L_{eff} = L_1 + L_2$; if the coils are wound on different cores

$L_{eff} = L_1 + L_2 + 2M$; if the coils are wound on the same core

COLPITT OSCILLATOR

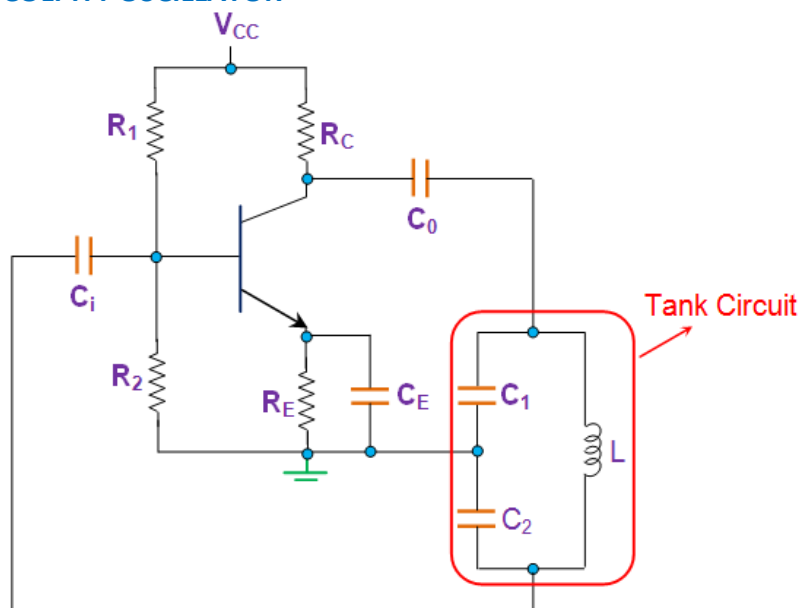

- **Colpitt Oscillator** is a type of LC oscillator. It consists of a tank circuit in which an inductor L is connected in parallel to the series combination of capacitors C_1 and C_2 .
- R_C is the collector resistor, R_E is the emitter resistor which is used to stabilize the circuit and the resistors R_1 and R_2 form the voltage divider bias network.
- The capacitors C_i and C_o are the input and output decoupling capacitors while the emitter capacitor C_E is the bypass capacitor used to bypass the amplified AC signals.

Working Principle

- As the power supply is switched ON, the transistor starts to conduct, increasing the collector current I_c due to which the capacitors C_1 and C_2 get charged.
- On acquiring the maximum charge feasible, they start to discharge via the inductor L .
- During this process, the electrostatic energy stored in the capacitor gets converted into magnetic flux which in turn is stored within the inductor in the form of electromagnetic energy.
- The inductor starts to discharge which charges the capacitors once again. Likewise, the cycle continues which gives rise to the oscillations in the tank circuit.
- The output of the amplifier appears across C_1 and thus is in-phase with the tank circuit's voltage.
- On the other hand, the voltage feedback to the transistor is the one obtained across the capacitor C_2 , which means the feedback signal is out-of-phase with the voltage at the transistor by 180° .
- This is due to the fact that the voltages developed across the capacitors C_1 and C_2 are opposite in polarity as the point where they join is grounded.
- Further, this signal is provided with an additional phase-shift of 180° by the transistor which results in a net phase-shift of 360° around the loop, satisfying the phase-shift criterion of Barkhausen principle.
- At this state, the circuit can effectively act as an oscillator producing sustained oscillations by carefully monitoring the feedback ratio given by (C_1 / C_2) . The frequency of such a **Colpitts Oscillator** depends on the components in its tank circuit and is given by

$$F = \frac{1}{2\pi\sqrt{LC_{eff}}}$$

Where, the C_{eff} is the effective capacitance of the capacitors expressed as $\frac{C_1 C_2}{C_1 + C_2}$

RC PHASE SHIFT OSCILLATOR

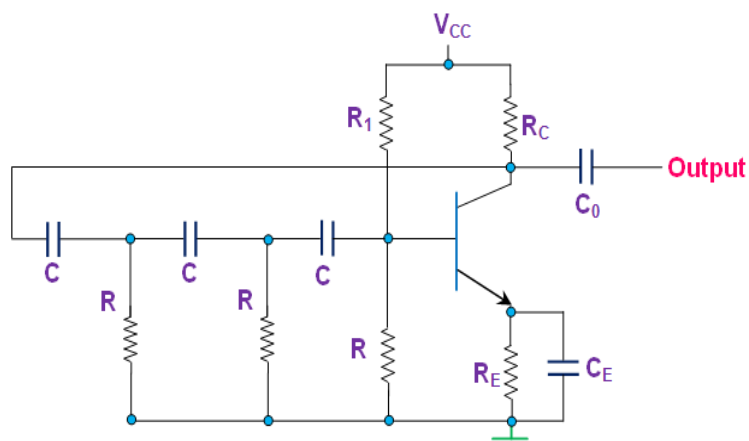

- A Phase Shift Oscillator is an electronic type of oscillator circuit that generates wave output in sine format. It uses resistor-capacitor (RC) network to provide the phase-shift required by the feedback signal.
- Ideally a simple RC network is expected to have an output which leads the input by 90° .
- However, in reality, the phase-difference will be less than this as the [capacitor](#) used in the circuit cannot be ideal. Mathematically the phase angle of the RC network is expressed as

$$\varphi = \tan^{-1} \frac{X_C}{R}$$

Where, $X_C = 1/(2\pi fC)$ is the reactance of the capacitor C and R is the [resistor](#).

- In oscillators these kind of RC phase-shift networks, each offering a definite phase-shift can be cascaded so as to satisfy the phase-shift condition led by the Barkhausen Criterion.
- **RC phase-shift oscillator** is formed by cascading three RC phase-shift networks, each offering a phase-shift of 60° .
- Here the collector resistor R_c limits the collector current of the transistor, resistors R_1 and R form the voltage divider network while the emitter resistor R_E improves the stability.
- The capacitors C_E and C_o are the emitter by-pass capacitor and the output DC decoupling capacitor, respectively.
- Further, the circuit also shows three RC networks employed in the feedback path.
- This arrangement causes the output waveform to shift by 180° during its course of travel from output terminal to the base of the transistor.
- This signal will be shifted again by 180° by the transistor in the circuit due to the fact that the phase-difference between the input and the output will be 180° in the case of common emitter configuration.
- This makes the net phase-difference to be 360° , satisfying the phase-difference condition. The generalized expression for the frequency of oscillations produced by a **RC phase-shift oscillator** is given by

$$f = \frac{1}{2\pi RC\sqrt{2N}}$$

Where, N is the number of RC stages formed by the resistors R and the capacitors C.

WEIN BRIDGE OSCILLATOR

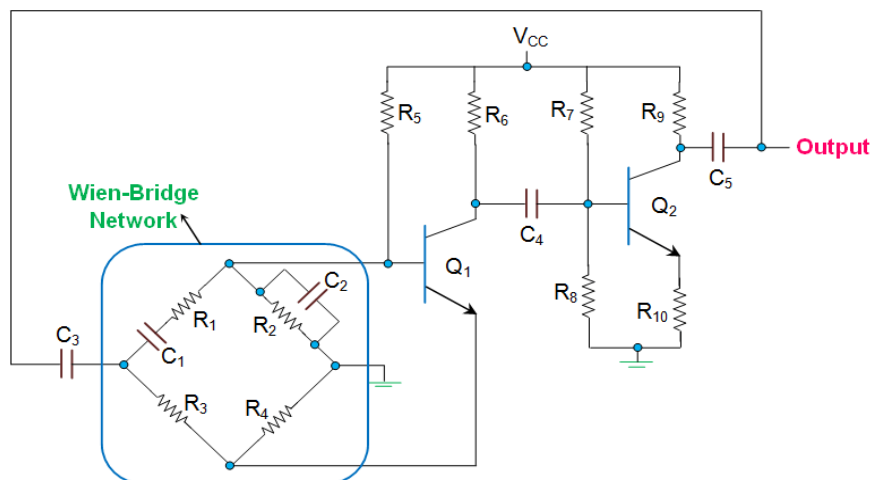

- A Wien-Bridge Oscillator is a type of phase-shift oscillator which is based upon a Wien-Bridge network comprising of four arms connected in a bridge fashion.
- Here two arms are purely resistive while the other two arms are a combination of resistors and capacitors.
- In particular, one arm has resistor and capacitor connected in series (R_1 and C_1) while the other has them in parallel (R_2 and C_2).
- This indicates that these two arms of the network behave identical to that of high pass filter or low pass filter.

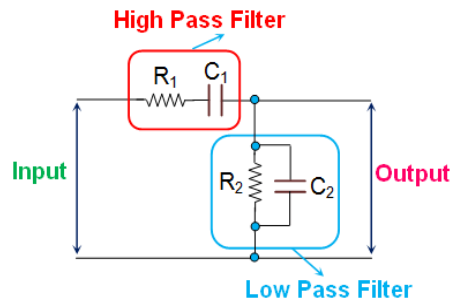

- At high frequencies, the reactance of the capacitors C_1 and C_2 will be much less due to which the voltage V_0 will become zero as R_2 will be shorted.
- At low frequencies, the reactance of the capacitors C_1 and C_2 will become very high due to which the output voltage V_0 will remain at zero only, as the capacitor C_1 would be acting as an open circuit.
- Between these two high and low frequencies, there exists a particular frequency at which the values of the resistance and the capacitive reactance will become equal to each other, producing the maximum output voltage. This frequency is referred to as resonant frequency. The resonant frequency for a Wien Bridge Oscillator is calculated using the following formula

$$f_r = \frac{1}{2\pi\sqrt{R_1 C_1 R_2 C_2}}$$

if $R_1 = R_2 = R$ and $C_1 = C_2 = C$

$$\text{then } f_r = \frac{1}{2\pi RC}$$

- Further, at this frequency, the phase-shift between the input and the output will become zero and the magnitude of the output voltage will become equal to one-third of the input value.
- In the case of **Wien-Bridge oscillator**, the Wien-Bridge network will be used in the feedback path as shown in Figure.
- In these oscillators, the amplifier section will comprise of two-stage amplifier formed by the transistors, Q_1 and Q_2 , wherein the output of Q_2 is back-fed as an input to Q_1 via Wien-Bridge network. Here, the noise inherent in the circuit will cause a change in the base current of Q_1 which will appear at its collector point after being amplified with a phase-shift of 180° .
- This is fed as an input to Q_2 via C_4 and gets further amplified and appears with an additional phase-shift of 180° . This makes the net phase-difference of the signal fed back to the Wien-Bridge network to be 360° , satisfying phase-shift criterion to obtain sustained oscillations.
- However, this condition will be satisfied only in the case of resonant frequency, due to which the Wien-Bridge oscillators will be highly selective in terms of frequency, leading to a frequency-stabilized design.

7.FIELD EFFECT TRANSISTOR

- The field effect transistor is a three terminal unipolar semiconductor device in which current is controlled by an electric field. The three terminals in this device are named drain, source, and gate.
- FETs are known as unipolar transistors because, unlike bipolar transistors, FETs only have either electrons or holes operating as charge carriers.
- FET uses the voltage applied to its input terminal (called the Gate), to control the current flowing from the source to drain, making the Field Effect Transistor a “Voltage” operated device.

Symbol:

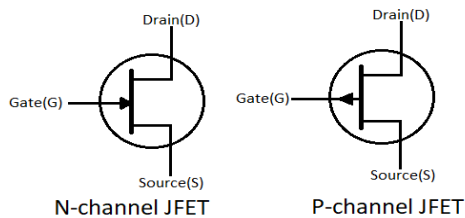

7.1 Classification of FET

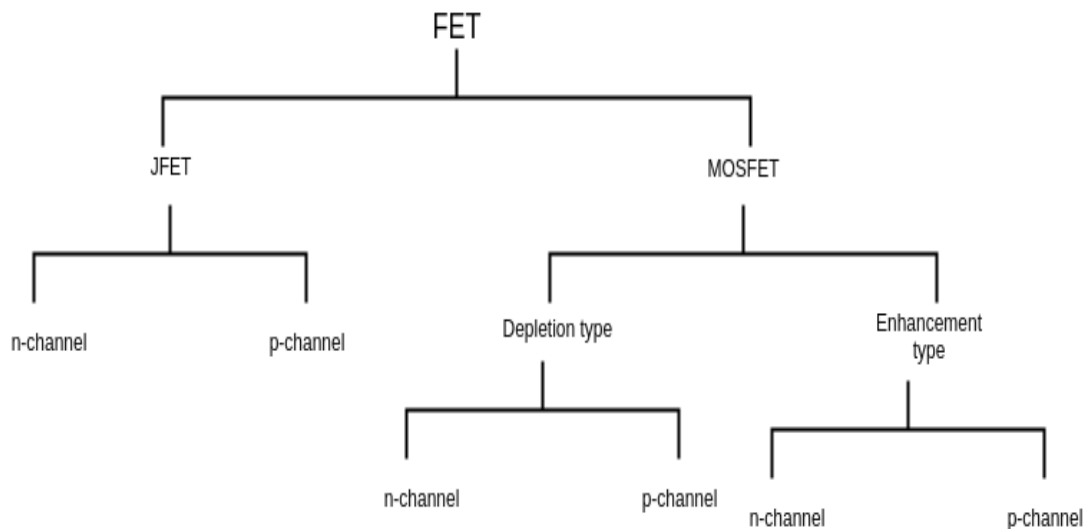

Construction

- FET can be fabricated with either N channel or P channel.

- For the fabrication of N channel JFET first a narrow bar of N type of semiconductor material is taken and then two P type junction are diffused on opposite sides of its middle part called channel.
- The two regions are internally connected to each other with a signal lead which is called Gate terminal, which is heavily doped regions that form two PN junctions.
- The terminal through which majority carriers are entered in the bar is called Source terminal.
- The terminal through which the majority carriers leaves the bar is called Drain.

7.2 Advantages of FET over BJT

- FET is a unipolar device, depending upon majority carriers.
- It has high input resistance.
- FET is less noisy than BJT
- FET is relatively less affected by radiation
- It has better thermal stability
- In integrated form, the fabrication of FET is simpler and it occupies less space.
- FET has smaller size, longer life and high efficiency.
- FET has very high power gain.

7.3 Principle of operation of FET

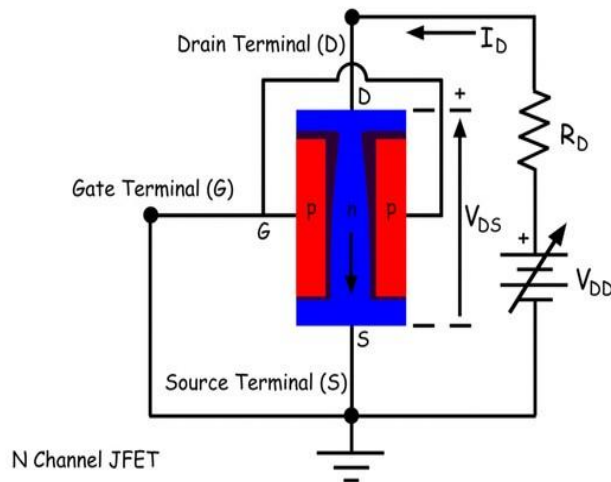

- The application of negative gate voltage or positive drain voltage with respect to source, reverse biases the gate-source junction of N-channel JFET.
- The effect of reverse bias voltage is to form the depletion regions within the channel.
- When a voltage is applied between the drain and source with a dc supply voltage (V_{DD}), the electrons tends to flow from source to drain side through the narrow channel existing between the depletion regions.

- This constitute the drain current (I_D) and its conventional direction is indicated from drain-to-source.
- The value of this drain current is maximum when no external voltage is applied between the gate and the source and is designated by I_{DSS} .
- When the gate-to-source voltage (V_{GS}) is applied by a dc supply (V_{GG}) and increased above zero, the reverse bias voltage across the gate-source junction is increased.

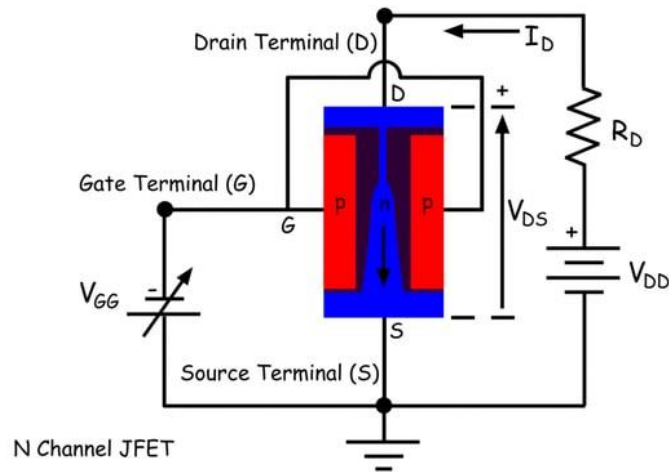

- Because of this, the depletion regions are widened. This reduces the effective width of the channel and hence controls the flow of drain current through the channel.
- When the gate-to-source voltage (V_{GS}) is further increased, a stage is reached at which two depletion regions touch each other.
- At this gate-to-source voltage, the channel is completely blocked or pinched off and drain current is reduced to zero.
- The drain-to-source voltage (V_{DS}) at which the drain current is zero (or completely cut off) is known as pinch off voltage.

Characteristic of JFET

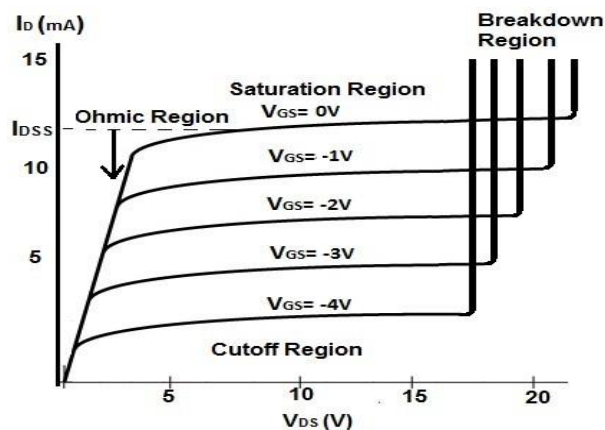

- The curve plotted between drain current I_D and drain-to-source voltage V_{DS} considering various value of gate-to-source voltage V_{GS} .

- When the positive voltage is applied to the drain to source terminal of JFET and when the gate to source voltage is zero, the Drain current starts flowing and the device is said to be in ohmic region.
- As the drain voltage is increased the channel of conductance tends to become narrower and current at the drain terminal gets smaller
- At a particular drain to source voltage called the pinch-off voltage the drain current reaches the saturation level.
- Now if a negative voltage is applied to the gate terminal then, in that case, the channel present at the gate is reverse biased and the saturation current starts decreasing further. At a particular gate voltage, the device stops conduction this is called the cut-off-voltage.
- But if the drain to source voltage is increased further then the device reaches the breakdown region in which the drain current increases indefinitely.

7.4 FET parameters (no mathematical derivation)

7.4.1 DC drain resistance

7.4.2 AC drain resistance

7.4.3 Trans-conductance

DC drain resistance

It is also known as static or ohmic resistance of the channel and is given by the ratio of drain-to-source voltage (V_{DS}) to the drain current (I_D).

Mathematically, the dc drain resistance is expressed as

$$R_{DS} = \frac{V_{DS}}{I_D}$$

AC drain resistance

It is also known as dynamic drain resistance and is the a.c resistance between the drain and the source terminal when the JFET is operating in the pinch off or saturation region.

It is given by the ratio of small change in drain-to-source voltage (ΔV_{DS}) to the corresponding change in drain current (ΔI_D) for a constant gate-to-source voltage (V_{GS}).

Mathematically, the ac drain resistance is expressed as

$$r_d = \frac{\Delta V_{DS}}{\Delta I_D}$$

Trans-conductance

It is the ratio of small change in drain current (ΔI_D) to the corresponding change in gate-to-source voltage (ΔV_{GS}) for a constant drain-to-source voltage (V_{DS}).

Mathematically, the Trans-conductance is expressed as

$$g_m = \frac{\Delta I_D}{\Delta V_{GS}}$$

The value of trans-conductance (g_m) is expressed in Siemens or mhos. The value of g_m varies depending upon the location on the curve as set by the gate-to-source voltage. It has greater value near the top of the curve than near the bottom.

7.5 Biasing of FET

- Biasing deals with setting a fixed level of current which should flow through the FET with a desired fixed voltage drop across the FET junction.
- Whatever be the biasing method, the gate-source junction of a JFET will always be reverse biased.
- The general relationships which can be applied to the dc analysis of all FET amplifier are $I_G \approx 0$ and $I_D = I_S$.
- The commonly used biasing circuits for FET are as under
 - 1.Fixed bias circuit
 - 2.Self bias circuit
 - 3.Voltage divider bias circuit

1.FIXED BIAS

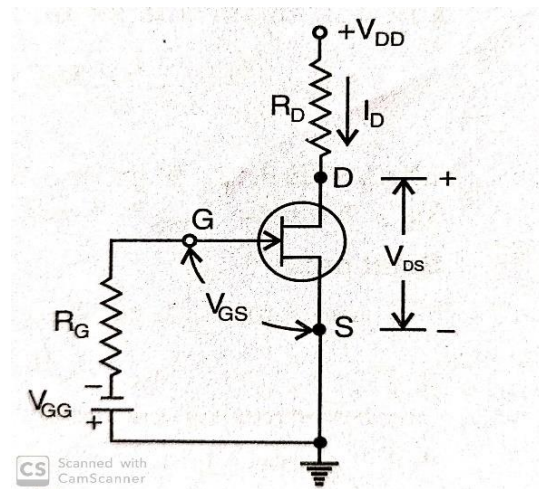

The fixed bias circuit is also known as gate bias circuit.

In the circuit, a battery V_{GG} is used such that its negative terminal is connected to the gate through R_G and positive terminal is earthed. This battery ensures that gate-source junction is reverse-biased.

Here, there is no gate current i.e. $I_G = 0$. So there is no voltage drop across R_G .

As zero voltage drop across R_G so it is short circuit in case of d.c analysis.

For d.c analysis $I_G = 0$

Applying Kirchhoff's voltage law to the input circuit, we have

$$V_{GG} + V_{GS} = 0$$

i.e, $V_{GS} = -V_{GG}$

The drain current is given by

$$I_D = I_{DSS} \left[1 - \frac{V_{GS}}{V_P} \right]^2$$

Applying Kirchoff's voltage law to output circuit,

$$V_{DS} = V_{DD} - I_D \cdot R_D$$

Since V_{GG} is fixed value of d.c supply and the magnitude of V_{GS} is also fixed, hence the circuit is named as Fixed bias circuit.

2. SELF BIAS

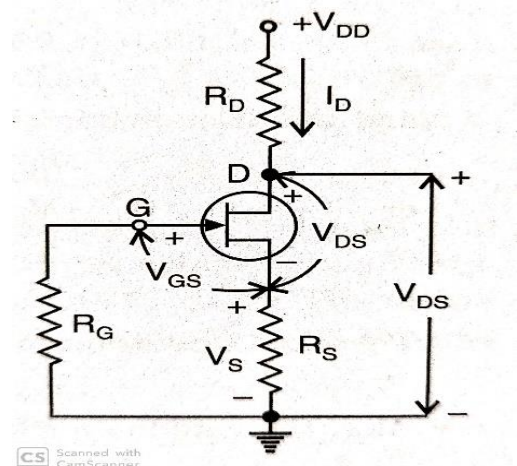

In this circuit, there is only one drain supply and no gate supply. The gate terminal is connected through a resistor (R_G) to the ground.

The source terminal is connected through (R_S) to the ground.

When the drain voltage is applied, a drain current flows even if there is no gate current.

The drain current produces a voltage drop across resistor R_S . The voltage drop produces the gate-to-source reverse voltage required for an FET operation.

The resistor R_S is known as feedback or bias resistor. Its function is to prevent any variation in the FET drain current.

Here we assume that the gate terminal is at zero voltage, the gate voltage with respect to ground, i.e $V_G = 0$

The source voltage with respect to ground is given by,

$$V_S = I_D \cdot R_S$$

And the drain voltage is given by,

$$V_D = V_{DD} - I_D \cdot R_D$$

The drain-to-source voltage (V_{DS}) is equal to the difference between the drain voltage (V_D) and the source voltage (V_S)

$$V_{DS} = V_D - V_S$$

$$V_{DS} = (V_{DD} - I_D \cdot R_D) - I_D \cdot R_S = V_{DD} - I_D(R_D + R_S)$$

The gate-to-source voltage (V_{GS}) is equal to the difference between the gate voltage (V_G) and the source voltage (V_S)

i.e
$$V_{GS} = V_G - V_S = 0 - I_D \cdot R_S = - I_D \cdot R_S$$

The gate-to-source voltage is equal to the negative of the voltage across the source resistor. Hence greater the value of drain current, more negative will be the gate-to-source voltage.

3.VOLTAGE DIVIDER BIAS

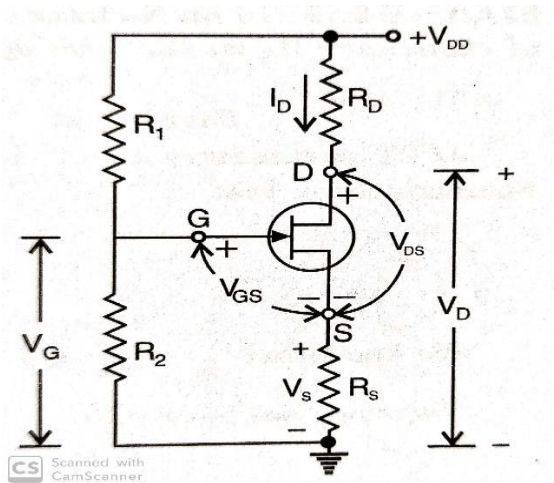

The name voltage divider is derived from the fact that the resistor R_1 and R_2 are connected on the gate side form a voltage divider across drain supply V_{DD} .

The gate voltage V_G is given by,
$$V_G = \frac{V_{DD} \cdot R_2}{R_1 + R_2}$$

The source voltage V_S is given by

$$V_S = V_G - V_{GS}$$

$$I_D \cdot R_S = V_G - V_{GS}$$

$$V_{GS} = V_G - I_D \cdot R_S$$

The circuit is so designed that $I_D \cdot R_S$ is larger than V_G so that V_{GS} is negative.

The value of drain current will be,

$$I_D = \frac{V_S}{R_S} = \frac{V_G - V_{GS}}{R_S}$$

The drain-to-source voltage is

$$V_{DS} = V_{DD} - I_D(R_D + R_S)$$

8. OPERATIONAL AMPLIFIER

- Operational amplifier is a Direct coupled high gain differential amplifier with a single output.
- Using op-amp it is possible to perform different mathematical operations (by connecting capacitors and resistors) like addition, subtraction, integration, differentiation etc.
- Op-amp consists of two inputs: 1.Inverting, 2.Non-inverting

CIRCUIT SYMBOL:

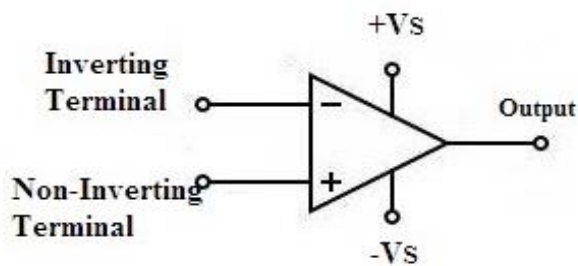

8.1 General circuit simple of OP-AMP and IC – CA – 741 OP AMP

Op-amp IC comes in the following form factors:

- 8 Pin DIP Package
- TO5-8 Metal can package
- 8 Pin SOIC

Pinout of IC 741 Op Amp and their Functions

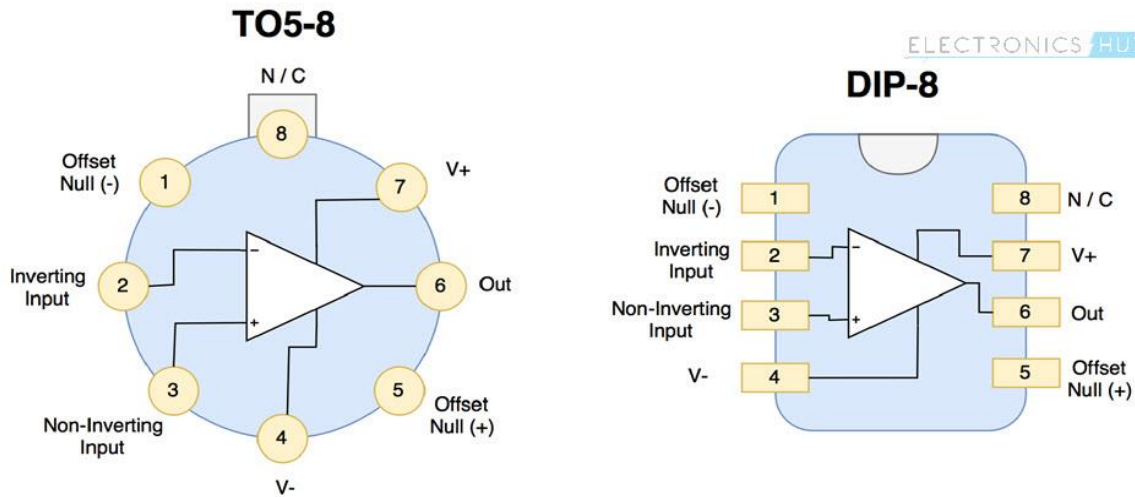

Pin4 & Pin7 (Power Supply)

Pin7 is the positive voltage supply terminal and Pin4 is the negative voltage supply terminal. The 741 IC draws in power for its operation from these pins. The voltage between these two pins can be anywhere between 5V and 18V.

Pin6 (Output)

This is the output pin of IC 741. The voltage at this pin depends on the signals at the input pins and the feedback mechanism used. If the output is said to be high, it means that voltage at the output is equal to positive supply voltage. Similarly, if the output is said to be low, it means that voltage at the output is equal to negative supply voltage.

Pin2 & Pin3 (Input)

These are input pins for the IC. Pin2 is the inverting input and Pin3 is the non-inverting input. If the voltage at Pin2 is greater than the voltage at Pin3, i.e., the voltage at inverting input is higher, the output signal stays low. Similarly, if the voltage at Pin3 is greater than the voltage at Pin2, i.e., the voltage at non-inverting input is high, the output goes high.

Pin1 & Pin5 (Offset Null)

Because of high gain provided by 741 Op-Amp, even slight differences in voltages at the inverting and non-inverting inputs, caused due to irregularities in manufacturing process or external disturbances, can influence the output. To nullify this effect, an offset voltage can be applied at pin1 and pin5, and is usually done using a potentiometer.

Pin8 (N/C)

This pin is not connected to any circuit inside 741 IC. It's just a dummy lead used to fill the void space in standard 8 pin packages.

8.2 Operational amplifier stages

OPERATIONAL AMPLIFIER STAGES

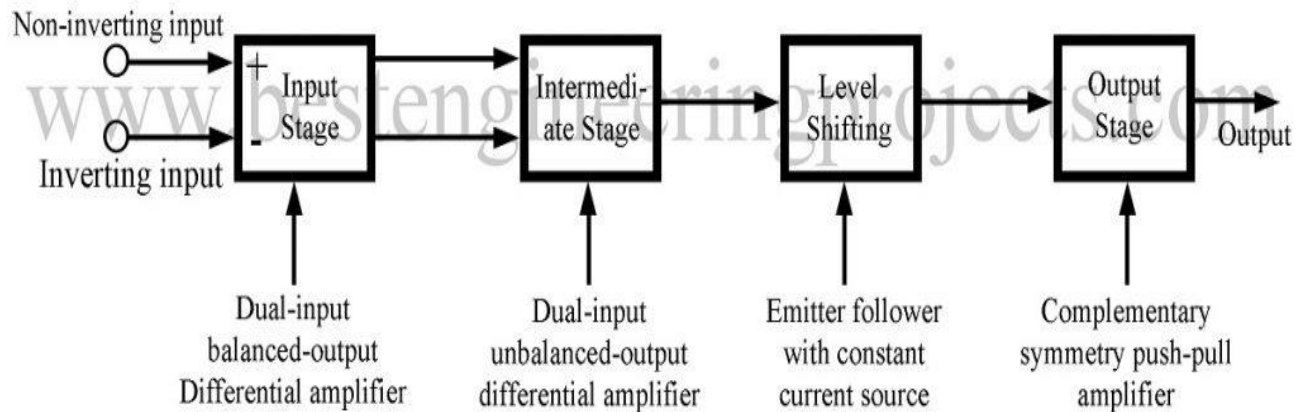

A general purpose op-amp is a multi-stage circuit. In general, it consists of four stage. It has two differential amplifier followed by level shifter and an output stage.

INPUT STAGE:

The input stage is a dual-input, balanced output differential amplifier. The function of differential amplifier is to provide most of the voltage gain to op-amp. The differential amplifier in the input stage rejects the common noise signals present at the input terminal and amplifies only the difference between the input signals.

INTERMEDIATE STAGE:

The intermediate stage is a dual input, unbalanced output differential amplifier. This is driven by the output of first stage and is used to provide some additional gain. There is direct coupling between the first two stages. So the D.C level at the output of intermediate stage is well above the ground level. This is undesirable.

LEVEL SHIFTING STAGE:

As direct coupling is used, the D.C at the output of the intermediate stage is well above the ground potential. Therefore, level shifter circuit is used after intermediate stage. Usually this is an emitter follower using constant current source. The function of level shifter is to shift the D.C level at the output of intermediate stage downwards to zero volt with respect to ground.

OUTPUT STAGE:

The output stage is generally push pull or complementary symmetry push pull amplifier. Its function is to increase large output voltage swing capability, large output swing capability of amplifier and to provide low output resistance.

8.3 Equivalent circuit of operational amplifier

EQUIVALENT CIRCUIT OF OPERATIONAL AMPLIFIER

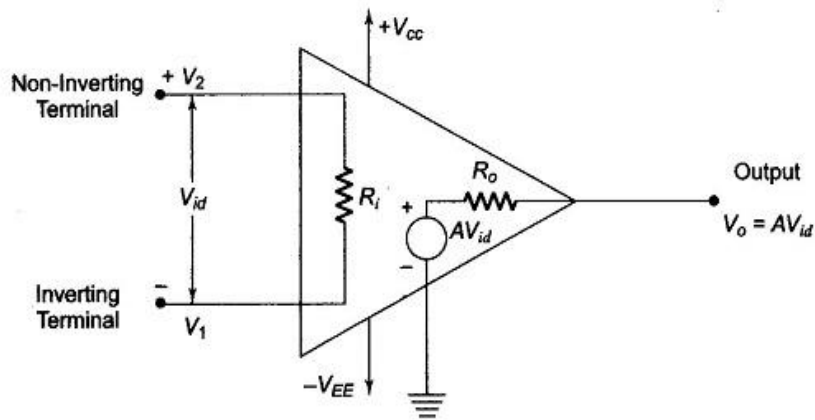

The basic operating principles of an op-amp can be analyzed with the help of the equivalent circuit. The output voltage is given by

$$V_o = A \cdot V_{id} = A (V_2 - V_1)$$

where

A = large signal voltage gain

V_{id} = differential input voltage

V_1 = voltage at Inverting terminal with respect to ground

V_2 = voltage at non-inverting terminal with respect to ground.

The output voltage is directly proportional to the algebraic difference between the inputs. The op-amp amplifies this difference voltage, not the input voltages themselves. For this reason the polarity of the output voltage depends on the polarity of the difference voltage.

An ideal op-amp is usually considered to have the following characteristics:

- Infinite open-loop gain
- Infinite input impedance
- Zero input offset voltage.
- Infinite output voltage range.
- Infinite bandwidth with zero phase shift
- Infinite slew rate.
- Zero output impedance
- Infinite CMRR.

8.4 Open loop OP-AMP configuration

In open-loop op-amp configuration, there is no connection between input and output and the op-amp works as a very high gain amplifier. The three open loop op-amp configurations are

- Differential amplifier
- Non-inverting amplifier
- Inverting amplifier

DIFFERENTIAL AMPLIFIER

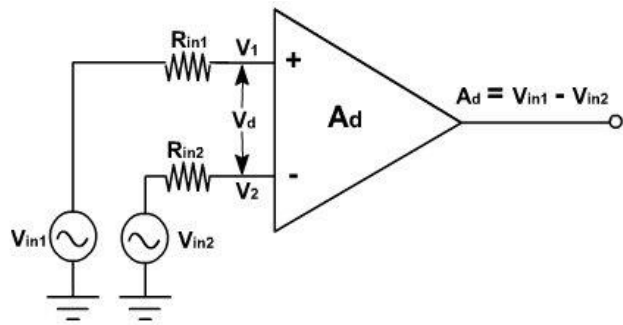

In open-loop differential amplifier, inputs are applied at both the inverting and non-inverting terminals. Since the difference between the two input signals is amplified, the configuration is called the differential amplifier.

We know that , $A = \frac{V_O}{V_{id}}$

$$V_O = A \cdot V_{id} = A (V_1 - V_2)$$

If two source resistances are neglected, then

$$V_1 = V_{i1} \text{ \& } V_2 = V_{i2}$$

Therefore, $V_O = A (V_{in1} - V_{in2})$

Where V_{in1} = voltage at the non-inverting terminal

V_{in2} = voltage at the inverting terminal

Here the output is A times of difference between two input voltages. The polarity of the output voltage depends upon the polarity of input difference voltage.

NON-INVERTING AMPLIFIER

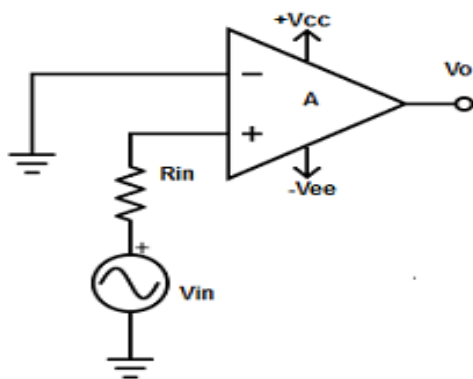

In non-inverting configuration, input is applied at the non-inverting terminal of the op-amp and inverting terminal is grounded. Also the output of non-inverting amplifier is in phase with the input.

We know that for an Open loop gain $A = \frac{V_O}{V_{id}}$

$$V_O = A \cdot V_{id} = A (V_1 - V_2)$$

Here $V_2 = 0$

So $V_O = A \cdot V_1 = A \cdot V_{in}$

The above equation shows that the output is A times larger than input and is in phase with the input.

INVERTING AMPLIFIER

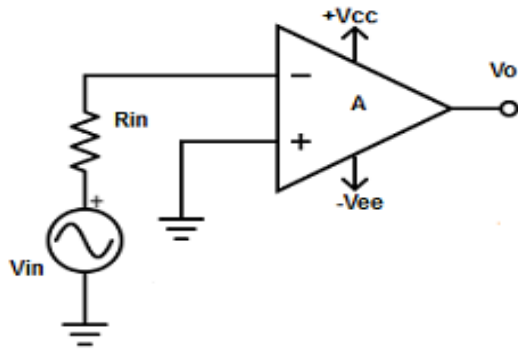

In inverting configuration, the input is applied at the inverting terminal and the non-inverting terminal is grounded. Also the output of inverting amplifier is out of phase with the input.

We know that Open loop gain $A = \frac{V_O}{V_{id}}$

$$V_O = A \cdot V_{id} = A (V_1 - V_2)$$

Here $V_1 = 0$

So $V_O = -A \cdot V_2 = A \cdot V_{in}$

The above equation shows that the output is A times larger than the input and is opposite in phase.

8.5 OPAMP with fed back

8.6 Inverting OP-AMP

8.7 Non inverting OP-AMP

CLOSED LOOP OP-AMP CONFIGURATION

- An open loop op-amp cannot be used in linear applications. However, an op-amp can be effectively used in linear applications by introducing feedback from the output to the input.
- If the signal feedback is out of phase by 180° with respect to the input, then the feedback is called negative feedback.
- On the other hand, if the signal feedback is in phase with that of the input then the feedback is called positive feedback.
- An op-amp that uses feedback is called a closed loop amplifier.

The most widely used closed loop configuration are

- Inverting amplifier
- Non-inverting amplifier

INVERTING AMPLIFIER

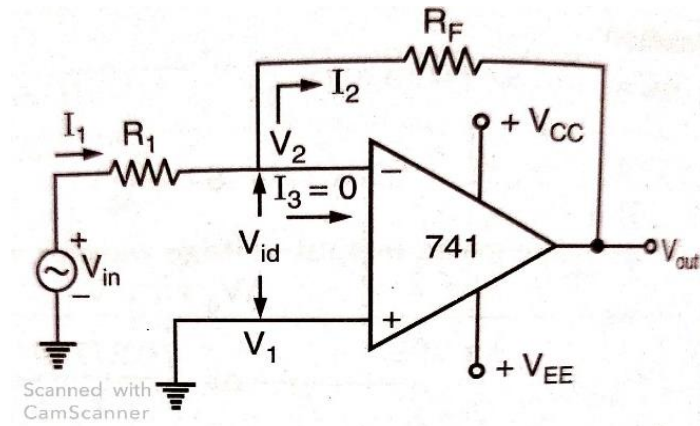

In closed loop inverting amplifier, the input is applied at the inverting terminal. The output of inverting amplifier is out of phase by 180° with respect to the input.

For an op-amp, we know that

$$A = \frac{V_O}{V_{id}}$$

$$V_1 - V_2 = \frac{V_O}{A} = \frac{V_O}{\infty} = 0$$

$$V_1 - V_2 = 0$$

$$\text{Or } V_1 = V_2$$

The potential difference between two terminals is zero. We can say that Virtual short circuit exists between the two input terminals. A virtual short circuit means that whenever is the voltage at non-inverting terminal, it will automatically appear at the inverting terminal because of the infinite voltage gain A .

Therefore, $V_1 = 0$

So $V_2 = 0$

The current I_{in} flowing through R_1 is

$$I_1 = \frac{V_{in} - V_2}{R_1}$$

But $V_2 = 0$, due to virtual short circuit.

$$\text{Therefore } I_1 = \frac{V_{in}}{R_1}$$

$$\text{Similarly, } I_2 = \frac{V_2 - V_O}{R_f}$$

As $V_2=0$ $I_2 = \frac{-V_0}{R_f}$

Now apply KCL at the node V_2 , we get

$$I_1 = I_2 + I_3$$

But here $I_3 \approx 0$ because ideal op-amp has an infinite input impedance and hence draws zero current.

Therefore $I_1 = I_2$

So $\frac{V_{in}}{R_1} = \frac{-V_0}{R_f}$

$$\frac{V_0}{V_{in}} = -\frac{R_f}{R_1}$$

The factor $\frac{V_0}{V_{in}}$ is called the closed loop gain A_f

Thus, $A_f = -\frac{R_f}{R_1}$

NON- INVERTING AMPLIFIER

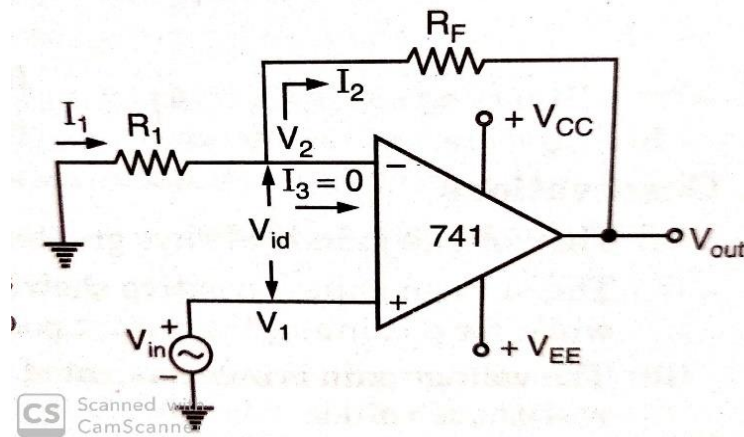

In a closed loop non-inverting amplifier, the external input signal is applied at the non-inverting terminal and the inverting terminal is grounded. The output of non-inverting amplifier is in phase with the input.

For an op-amp, we know that

$$A = \frac{V_0}{V_{id}}$$

$$(V_1 - V_2) = \frac{V_0}{A} = \frac{V_0}{\infty} = 0$$

$$V_1 - V_2 = 0$$

$$\text{Or } V_1 = V_2$$

Applying Kirchhoff's law at V_2 ,

$$I_1 = I_2$$

The value of currents I_1 and I_2 are given as

$$I_1 = \frac{-V_2}{R_1} = \frac{-V_{in}}{R_1} \quad \text{and} \quad I_2 = \frac{V_0 - V_2}{R_f} = \frac{V_0 - V_{in}}{R_f}$$

$$\text{So} \quad \frac{V_{in}}{R_1} = \frac{V_0 - V_{in}}{R_f}$$

$$\frac{V_0}{R_f} = V_{in} \left(\frac{1}{R_1} + \frac{1}{R_f} \right)$$

$$\frac{V_0}{V_{in}} = \left(1 + \frac{R_f}{R_1} \right)$$

$$A_f = \left(1 + \frac{R_f}{R_1} \right)$$

Here the output voltage is in phase with the input voltage. This circuit offers a high input impedance and low output impedance.

8.8 Voltage follower & buffer

VOLTAGE FOLLOWER/BUFFER AMPLIFIER

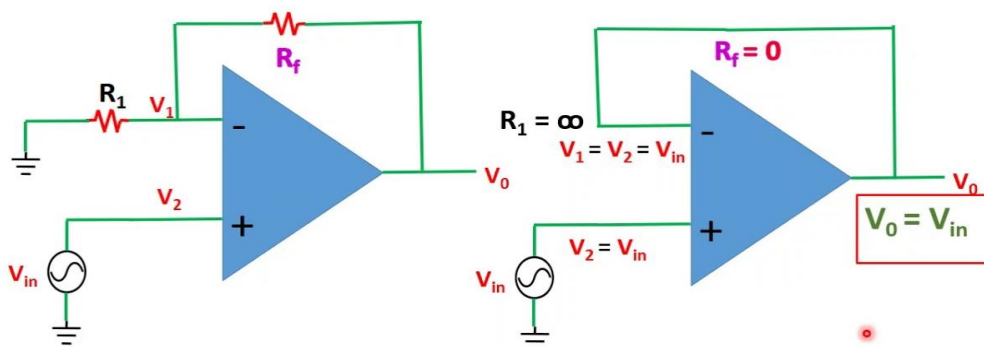

- Voltage follower is simply a circuit in which output follows the input means output voltage remains same as input voltage. It is also known as buffer amplifier or unity gain amplifier.
- If R_1 is infinite means open circuit and R_f is zero means short circuit, the circuit of non-inverting amplifier becomes voltage follower.

The gain for a closed loop non-inverting amplifier is expressed as

$$A_f = 1 + \frac{R_f}{R_1}$$

Now, if $R_f = 0$ (short)

And $R_1 = \infty$ (open)

Substitute these two conditions in the above equation

$$A_f = 1 + 0 = 1$$

$$\frac{V_o}{V_i} = 1$$

$$V_o = V_i$$

This means that the op-amp does not provide any amplification to the signal.

The voltage follower circuit is required when a signal from a high impedance source is to be amplified and no signal current is to be drawn.

8.9 Differential amplifier

8.9.1 Adder or summing amplifier

ADDER OR SUMMING AMPLIFIER

Since the input impedance of an op-amp is extremely large, more than one input signal can be applied to the inverting or non-inverting amplifier. Such a circuit gives the addition of the applied signals at the output. Hence it is called a Summer or Adder circuit.

Inverting Adder:

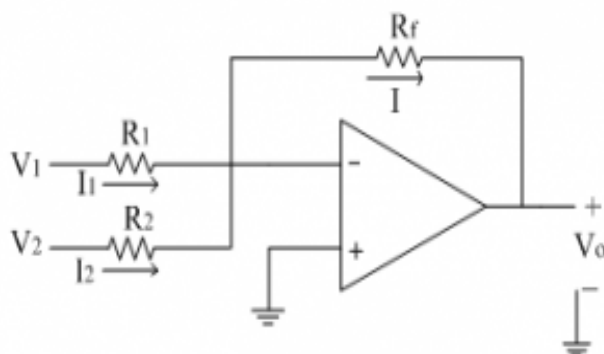

Applying KCL at the inverting terminal, we get

$$I = I_1 + I_2$$

Substituting for the currents,

$$\frac{0-V_o}{R_f} = \frac{V_1-0}{R_1} + \frac{V_2-0}{R_2}$$

$$\therefore \frac{-V_o}{R_f} = \frac{V_1}{R_1} + \frac{V_2}{R_2}$$

$$\therefore V_o = - \left[\frac{R_f V_1}{R_1} + \frac{R_f V_2}{R_2} \right]$$

If $R_1=R_2=R$

$$\therefore V_o = - \frac{R_f}{R} [V_1 + V_2]$$

Thus the addition of the two input signals obtained with gain $[-R_f/R]$

If $R_f=R$,

$$\therefore V_o = -[V_1 + V_2]$$

Thus the addition of two inputs obtained. The negative sign indicates that input and output are having 180° phase shift.

Non-inverting Adder:

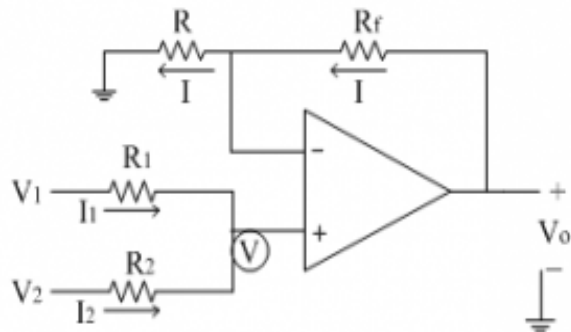

Applying KCL at non-inverting terminal, we get

$$I_1 + I_2 = 0$$

$$\frac{V_1 - V}{R_1} + \frac{V_2 - V}{R_2} = 0$$

$$\therefore \frac{V_1}{R_1} + \frac{V_2}{R_2} = V \left[\frac{1}{R_1} + \frac{1}{R_2} \right]$$

$$\therefore V \left[\frac{R_1 + R_2}{R_1 R_2} \right] = \left[\frac{V_2 R_1 + V_1 R_2}{R_1 R_2} \right]$$

$$\therefore V = \left[\frac{V_2 R_1 + V_1 R_2}{R_1 + R_2} \right]$$

The current 'I' from the feedback path is given as,

$$I = \left[\frac{V_o - V}{R_f} \right] = \left[\frac{V - 0}{R} \right]$$

Solving the above equation for V_o , we get

$$\frac{V_o}{R_f} - \frac{V}{R_f} = \frac{V}{R}$$

$$\therefore \frac{V_o}{R_f} = V \left[\frac{R_f + R}{RR_f} \right]$$

$$\therefore V_o = V \left[\frac{R_f + R}{R} \right]$$

Substituting voltage 'V' from equation (1) in above V_o equation

$$V_o = \left[\frac{V_1 R_2 + V_2 R_1}{R_1 + R_2} \right] \left[\frac{R_f + R}{R} \right]$$

$$\therefore V_o = V_1 \left[\frac{R_2 (R_f + R)}{(R_1 + R_2) R_2} \right] + V_2 \left[\frac{R_1 (R_f + R)}{(R_1 + R_2) R_2} \right]$$

If, $R_1 = R_2 = R = R_f$

$$\therefore V_o = V_1 + V_2$$

8.9.2 Subtractor

Subtractor

- A subtractor is an electronic circuit that produces an output, which is equal to the difference of the applied inputs.
- It is also called as a difference amplifier, since the output is an amplified one.

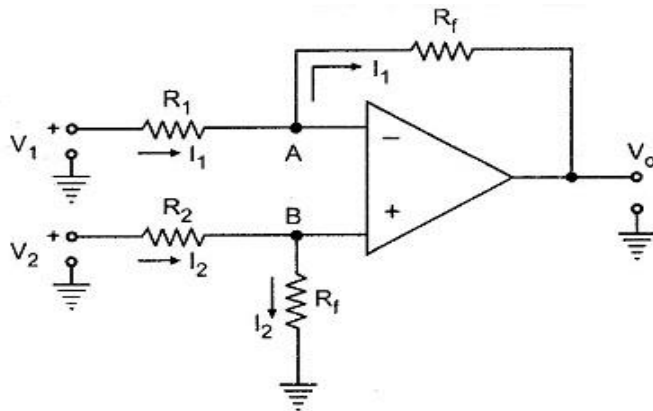

Let V_{o1} be the output, with input V_1 acting, assuming V_2 to be zero. And V_{o2} be the output, with input V_2 acting, assuming V_1 to be zero.

With V_2 zero, the circuit acts as an inverting amplifier. Hence output voltage will be

$$V_{o1} = -\frac{R_f}{R_1} V_1 \quad \dots (1)$$

While with V_1 as zero, circuit acts as a non inverting amplifier & the circuit reduces to as shown in the fig below

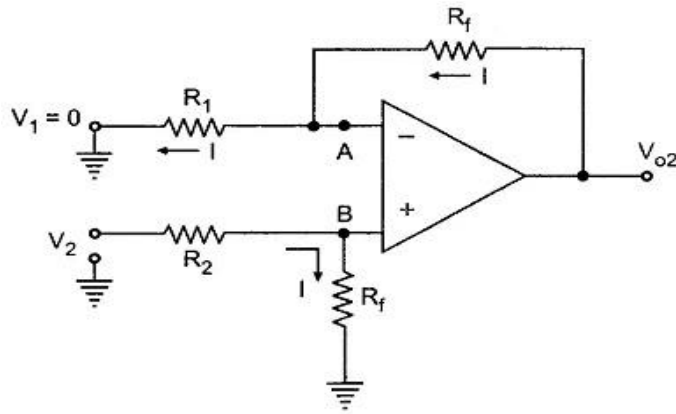

Let potential of node B be V_B . The potential of node A is same as B i.e. $V_A = V_B$. Applying voltage divider rule to the input V_2 loop,

$$V_B = \frac{R_f}{R_2 + R_f} V_2 \quad \dots (2)$$

$$I = \frac{V_A}{R_1} = \frac{V_B}{R_1} \quad \dots (3)$$

$$I = \frac{V_{o2} - V_A}{R_f} = \frac{V_{o2} - V_B}{R_f} \quad \dots (4)$$

Equating the equations (3) and (4),

$$\frac{V_B}{R_1} = \frac{V_{o2} - V_B}{R_f}$$

$$V_{o2} = \frac{R_1 + R_f}{R_1} V_B$$

$$V_{o2} = \left[1 + \frac{R_f}{R_1} \right] V_B \quad \dots (5)$$

Substituting V_B from (2) in (5) we get,

$$V_{o2} = \left[1 + \frac{R_f}{R_1} \right] \left[\frac{R_f}{R_2 + R_f} \right] V_2 \quad \dots (6)$$

Hence using Superposition principle,

$$\begin{aligned} V_o &= V_{o1} + V_{o2} \\ &= -\frac{R_f}{R_1} V_1 + \left[1 + \frac{R_f}{R_1} \right] \left[\frac{R_f}{R_2 + R_f} \right] V_2 \quad \dots (7) \end{aligned}$$

Now if the resistances are selected as $R_1 = R_2$,

$$\begin{aligned} V_o &= -\frac{R_f}{R_1} V_1 + \left[1 + \frac{R_f}{R_1}\right] \left[\frac{R_f}{R_1 + R_f}\right] V_2 \\ &= -\frac{R_f}{R_1} V_1 + \frac{R_f}{R_1} V_2 \\ V_o &= +\frac{R_f}{R_1} (V_2 - V_1) \quad \dots (8) \end{aligned}$$

Thus the output voltage is proportional to the difference between the two input voltages. Thus it acts as a Subtractor using Op Amp circuit or difference amplifier.

If $R_1 = R_2 = R_f$ is selected,

$$V_o = V_2 - V_1 \quad \dots (9)$$

But by selecting proper values of R_1 , R_2 and R_f , we can have the subtraction of two inputs.

8.9.3 Integrator

INTEGRATOR

- An Integrator is an op-amp circuit; whose output signal is proportional to the integral of input signal.
- The integrator is an inverting op-amp in which feedback resistor R_f has been replaced by a capacitor C_f .

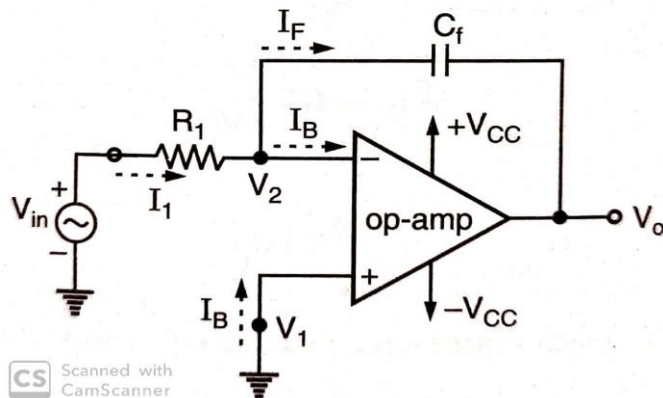

Applying Kirchhoff's current law at node V_2

$$I_1 = I_B + I_F$$

Due to high input impedance R_1 of the op-amp, I_B will be negligible as compared to I_F

Therefore $I_1 \approx I_F$

The basic relation between the current and voltage across a capacitor is

$$I_c = C_f \frac{dV_c}{dt} \quad \dots(1)$$

But
$$I_1 = \frac{V_{in} - V_2}{R_1}$$

And $V_c = V_2 - V_0$

Substitute these values in equation (1)

$$\frac{V_{in} - V_2}{R_1} = C_f \cdot \frac{d}{dt}(V_2 - V_0) \quad \dots\dots(2)$$

Using the concept of virtual ground, we can write

$$V_1 = V_2 = 0$$

Substituting this value into equation (2)

$$\frac{V_{in}}{R_1} = C_f \cdot \frac{d}{dt}(-V_0)$$

The output voltage can be obtained by integrating the above equation as under

$$V_0 = -\frac{1}{R_1 C_f} \int_0^t V_{in} dt + C$$

Where C is the integration constant and it is proportional to the output voltage V_0 at $t=0$ seconds.

8.9.4 Differentiator

DIFFERENTIATOR

- Differentiator is an op amp based circuit, whose output signal is proportional to differentiation of input signal.
- The differentiator is an inverting op-amp in which input resistance R_1 is replaced by a capacitor C_1 .

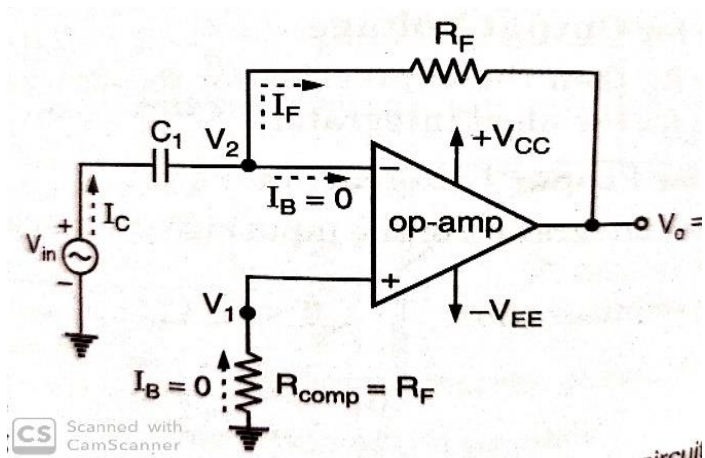

Applying Kirchhoff's current law at node V_2

$$I_C = I_B + I_F \quad \dots (1)$$

But, since $I_B \approx 0$ the equation(1) will be

$$I_C = I_F \dots (2)$$

Here
$$I_C = C_1 \frac{dV_C}{dt} \quad \dots (3)$$

The voltage across C_1 is given by

$$V_C = V_{in} - V_2$$

Substituting this in equation (3), we get

$$I_C = C_1 \frac{d}{dt}(V_{in} - V_2)$$

Now
$$I_F = \frac{V_2 - V_0}{R_f}$$

So equation (2) becomes

$$C_1 \frac{d}{dt}(V_{in} - V_2) = \frac{V_2 - V_0}{R_f} \dots (4)$$

Using the concept of virtual ground, we can write that

$$V_1 = V_2 = 0$$

So equation (4) becomes

$$C_1 \frac{d}{dt}(V_{in}) = \frac{-V_0}{R_f}$$

Therefore, $V_0 = -R_f \cdot C_1 \frac{d}{dt}(V_{in})$

Thus, the output is $-R_f \cdot C_1$ times the derivative of the input voltage.

8.9.5 Comparator

Comparator is an electronic circuit which compares two voltages and provides an output that indicates the relationship between them. Comparators are of two types: Inverting and Non-inverting.

Inverting Comparator

An inverting comparator is an op-amp based comparator for which a reference voltage is applied to its non-inverting terminal and the input voltage is applied to its inverting terminal. This comparator is called as inverting comparator because the input voltage, which has to be compared is applied to the inverting terminal of op-amp.

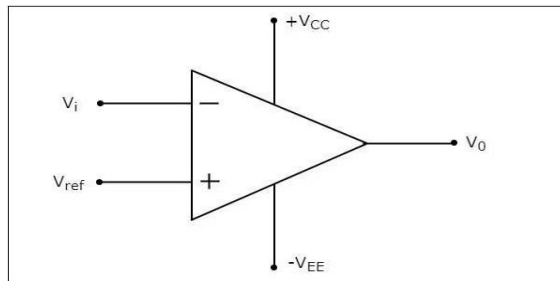

The operation of an inverting comparator is very simple. It produces one of the two values, $+V_{sat}$ and $-V_{sat}$ at the output based on the values of its input voltage V_i and the reference voltage V_{ref} .

- The output value of an inverting comparator will be $-V_{sat}$, for which the input V_i voltage is greater than the reference voltage V_{ref} .
- The output value of an inverting comparator will be $+V_{sat}$, for which the input V_i is less than the reference voltage V_{ref} .

Non-Inverting Comparator

A non-inverting comparator is an op-amp based comparator for which a reference voltage is applied to its inverting terminal and the input voltage is applied to its non-inverting terminal. This op-amp based comparator is called as **non-inverting** comparator because the input voltage, which has to be compared is applied to the non-inverting terminal of the op-amp.

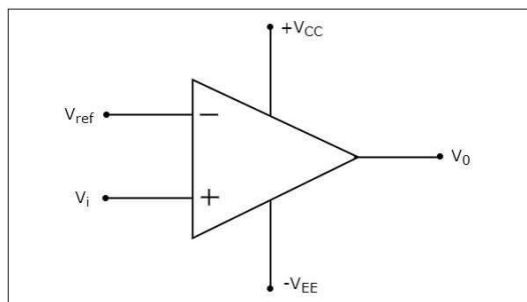

The operation of a non-inverting comparator is very simple. It produces one of the two values, $+V_{sat}$ and $-V_{sat}$ at the output based on the values of input voltage V_i and the reference voltage $+V_{ref}$.

- The output value of a non-inverting comparator will be $+V_{sat}$, for which the input voltage V_i is greater than the reference voltage $+V_{ref}$.
- The output value of a non-inverting comparator will be $-V_{sat}$, for which the input voltage V_i is less than the reference voltage $+V_{ref}$.

CMRR (Common mode rejection ratio)

The common mode rejection ratio is defined as the ratio of the differential voltage gain A_d to the common mode voltage gain A_c .

$$CMRR = \left| \frac{A_d}{A_c} \right|$$

Where

A_d = gain of op-amp when two different voltages are applied at the two inputs.

A_c = common mode voltage gains of op-amp when the two terminals of op-amp are applied with the same voltage from the same source.

SLEW RATE

The slew rate may be defined as the maximum rate of change of output voltage with time.

The slew rate is specified in $V/\mu \text{ sec}$. This means that

$$\text{Slew rate} = S = \left. \frac{dV_{out}}{dt} \right|_{max}$$