

5TH  
SEM,

# POWER ELECTRONICS & PLC

The development of high power semiconductor devices has facilitated electronic control techniques for electrical power control in a simple, economic and efficient manner. Thus a new area of power electronics has now emerged which replaced the old and bulky method of power control through the use of small electronic devices. Power electronics application has occupied an indispensable position in industrial applications like heating, welding, uninterrupted power supply, battery charging etc. Industrial drives, lighting control are most efficiently controlled by power electronics devices to achieve optimum performance. The objective of this paper is to familiar students with the principles and operations of Power electronics devices in Industrial applications with drives control.



# POWER ELECTRONICS AND PLC

## Chapter-1

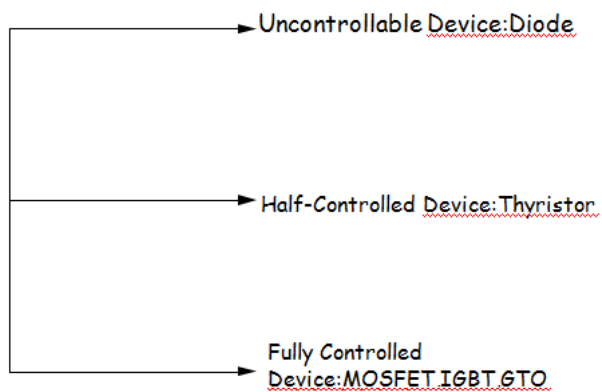
### UNDERSTAND THE CONSTRUCTION AND WORKING OF POWER ELECTRONIC DEVICE:

#### INTRODUCTION:

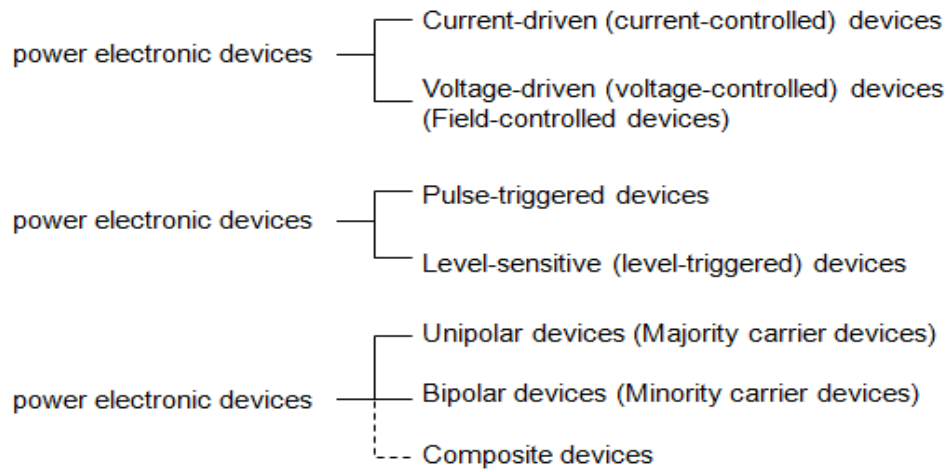
The control of electric motor drives requires control of electric power. Power electronics have eased the concept of power control. Power electronics signifies the word power electronics and control or we can say the electronic that deal with power equipment for power control.

Power electronic devices: Power electronic devices are the electronic devices that can be directly used in the power processing circuits to convert or control electric power.

#### CLASSIFICATION OF POWER ELECTRONIC DEVICES:



Other classifications:



Power Devices are :

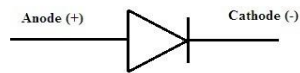
1. Power Diodes
2. Power Metal-Oxide-Semiconductor Field-Effect Transistor (MOSFET)
3. Power Bipolar -Junction Transistor (BJT)
4. Insulated-Gate Bipolar Transistor (IGBT)
5. Thyristors (SCR, GTO, MCT, IGCT)
6. Diac
7. Triac

### Types of Diodes:

P-N Junction Diode:

This is the basic diode formed with the interaction of p-type and n-type materials. It deals with the concept of biasing. This biasing make it classify into various operating modes.

This diode conducts only during forwarding bias. In reverse bias, there is no evident flow of the current. It indicates that current gets blocked during reverse bias.

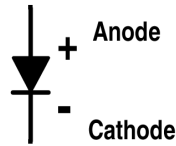


**Zener Diode:** Are specifically designed to operate under reverse breakdown conditions. These diodes have a very accurate and specific reverse breakdown voltage.

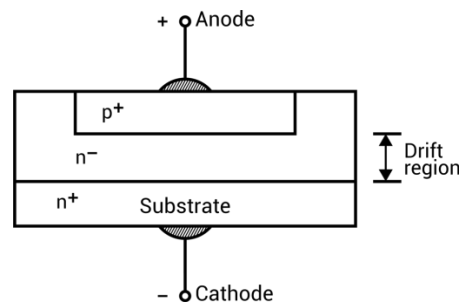
### Power Diodes

A power diode has a P-I-N structure as compared to the signal diode having a P-N structure. Here, I (in P-I-N) stands for intrinsic semiconductor layer to bear the high-level reverse voltage as compared to the signal diode (n- , drift region layer shown in Fig. 2). However, the drawback of this intrinsic layer is that it adds noticeable resistance during forward-biased condition. Thus, power diode requires a proper cooling arrangement for handling large power

dissipation. Power diodes are used in numerous applications including rectifier, voltage clamper, voltage multiplier and etc. Power diode symbol is the same as of the signal diode as shown in Fig.1.



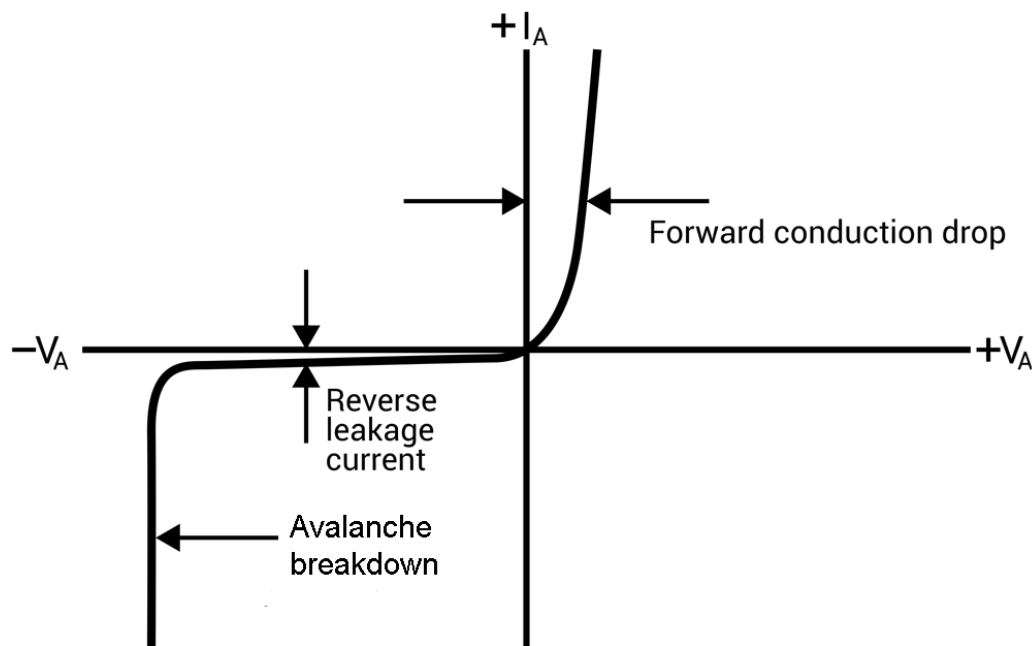
**Figure 1. Symbol for Power Diode**



**Figure 2. Structure of Power Diode**

- Near the PN junction the electrons diffuse into the vacant holes in the P material causing a depletion zone.
- This depletion zone acts like an insulator preventing other free electrons in the N-type silicon and holes in the P-type silicon from combining.
- In addition this leaves a small electrical imbalance inside the crystal. Since the N region is missing some electrons it has obtained a positive charge. And the extra electrons that filled the holes in the P region, have given it a negative charge. Unfortunately one cannot generate power from this electrical imbalance. However the stage is set to see how the PN junction functions as a diode.
- At the p-n junction, electrons from the n-type semiconductor will be attracted to the holes in the p-type semiconductor.
- As a result, the holes and the electrons at the p-n junction disappear, forming a layer called “depletion layer”.
- At the same time, the p-type semiconductor becomes more negative whereas the n-type semiconductor becomes more positive.
- This will result a potential difference across the p-n junction. This potential difference is called the junction voltage (or the barrier voltage).
- The junction voltage will prevent the charge carrier from flowing across the depletion layer.
- The polarity of applied voltage which causes charge to flow through the diode is called Forward Bias. (all current, almost no volts)
- The polarity of applied voltage which can't produce any current is called Reverse Bias.(all volts, almost no current)

**I-V Characteristics of diode:**



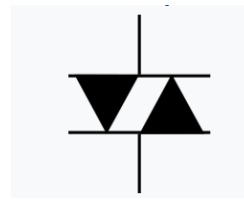
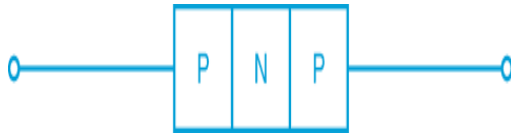
- Forward region: It is the operation region at which the potential applied to anode is more positive than that applied to the cathode.
- Reverse Region: It is the operation region at which anode potential is more negative than cathode potential.
- Saturation Region: Part of the reverse region where the diode impedance is very high, and causes very small drift current.
- Break Down Region: The part of the reverse region where the diode impedance is very low, and the current passing through the diode is very high.
- Threshold Voltage  $V_T$ : It is also called the knee region. It can be determined on the I-V curve by the point at which diode starts to conduct current easily. It is also called the diode barrier potential and is very near in amplitude to the diode build-in voltage.
- Saturation Current: it is a very small current due to drift current in the diode in the reverse bias region. This current is very low (in the nano-amperes range) due to the high impedance of the depletion region.
- Break Down Voltage: It is the maximum allowable voltage in the reverse bias region, at which diode resistance changed abruptly from very high impedance to very low impedance. If the reverse voltage applied on the diode exceeds this limit, a very high current in the reverse direction passes through the diode causing in burning it.

#### DIODE APPLICATION

- DC Power Supply
- Rectifier
- Filter
- Voltage regulator

#### DIAC:

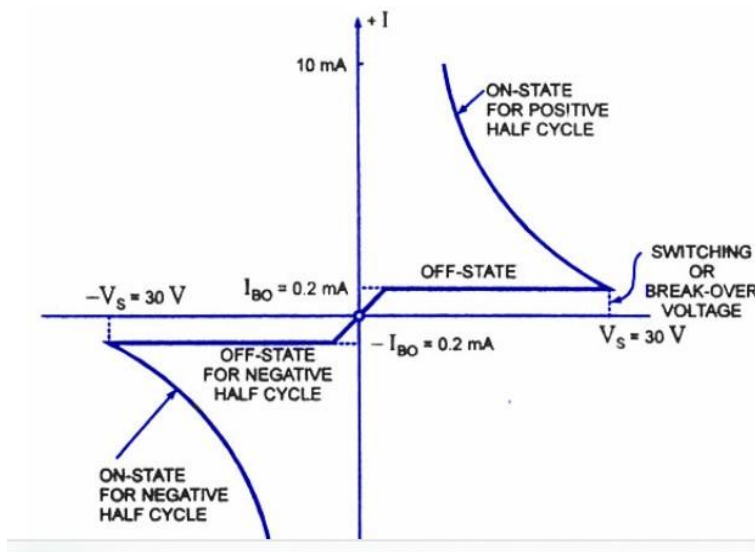
The DIAC is a diode that conducts electrical current only after its breakover voltage,  $V_{BO}$ , has been reached momentarily.



#### DIAC construction:

- Three alternately doped layers.
- The doping concentration around both junctions is equal.
- Leads are only attached to the outer layers.
- Packaged like a PN junction diode.
- A DIAC has the same effect on current regardless of the direction of flow.
- One junction is forward biased.
- The other is reverse biased.
- It is a bidirectional device that can pass the current in both forward and reverse biased conditions and hence it is an AC control device.
- Performs as if it contained two PN junction diodes connected in series back-to-back.
- Useful for controlling
  - lamps
  - heaters
  - speeds of small motors

#### V-I CHARACTERISTICS OF OF DIAC :



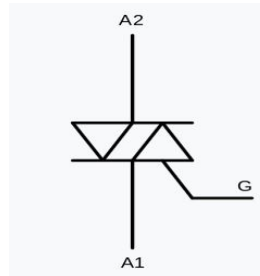
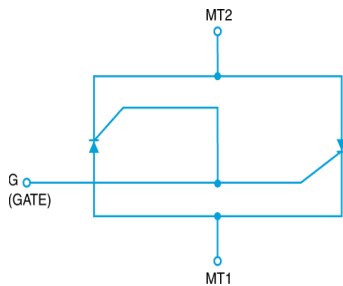
1. The diac performs like an open-circuit until its switching is exceeded.
2. At that position the diac performs until its current decreases toward zero.
3. Because of its abnormal construction, doesn't switch sharply into a low voltage condition at a low current level like the triac or SCR, once it goes into transmission, the diac preserves an almost continuous -ve resistance characteristic, that means, voltage reduces with the enlarge in current.
4. This means that, unlike the triac and the SCR, the diac cannot be estimated to maintain a low voltage drop until its current falls below the level of holding current.

## TRIAC

### Construction And Operation:

The triac is another three-terminal ac switch that is triggered into conduction when a low-energy signal is applied to its gate terminal. Unlike the SCR, the triac conducts in either direction when turned on. The triac also differs from the SCR in that either a positive or negative gate signal triggers it into conduction. Thus the triac is a three terminal, four layer bidirectional semiconductor device that controls ac power whereas an **SCR controls** dc power or forward biased half cycles of ac in a load. Because of its bidirectional conduction property, the triac is widely used in the field of power electronics for control purposes. Triacs of 16 kW rating are readily available in the market.

- TRIACs
  - An acronym for *triode AC* semiconductor.
  - Conduct both directions of AC current flow.
  - Have the same switching characteristics as SCRs.
  - Equivalent to two SCRs connected in parallel, back to back.



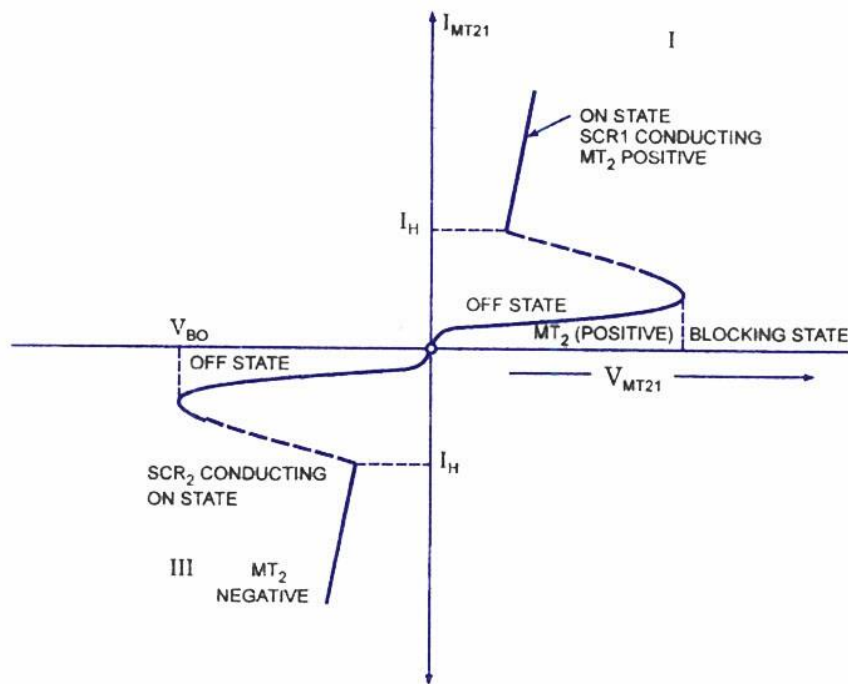
TRIACs are widely used to control application of power to various types of loads.

- TRIAC construction
  - A four-layer NPNP device in parallel with a PNP device.
  - Designed to respond to a gating current through a single gate.
  - Not equally sensitive to the gate current flowing in opposite directions.

TRIACs from 50 to 500 hertz.

TRIACs have difficulty switching power to inductive loads.

V-I CHARACTERISTICS OF OF TRIAC:



1. The V-I characteristics of triac in the first and third quadrants are basically equal to those of an SCR in the first quadrant.
2. It can be functioned with either +Ve or -Ve gate control voltage but in typical operation generally the gate voltage is +Ve in first quadrant and -Ve in third quadrant.

### Power Electronic Devices That Act As Solid-State Switches

This technical article is dedicated to the review of the following power electronic devices which act as solid-state switches in the circuits. They act as a switch without any mechanical movement.

- Power Diodes
- Metal-Oxide-Semiconductor Field-Effect Transistor (MOSFET)
- Bipolar -Junction Transistor (BJT)
- Insulated-Gate Bipolar Transistor (IGBT)
- Thyristors (SCR, GTO, MCT)

Solid-state devices are completely made from a solid material and their flow of charges is confined within this solid material. This name "solid state" is often used to show a difference with the earlier technologies of vacuum and gas-discharge tube devices; and also to exclude the conventional electro-mechanical devices (relays, switches, hard drives and other devices with moving parts).

The transistor by Bell Labs in 1947 was the first solid-state device to come into commercial use later in the 1960s. In this article, similar solid-state devices such as power diode, power transistor, MOSFET, thyristor and its two-transistor model, triac, gate turn-off thyristor (GTO), insulated-gate bipolar transistor (IGBT) and their characteristics (such as i-v characteristics and turn-off characteristics) is also presented. In power electronics circuitry, these switches act in saturation region and work in linear region in the analog circuitry such as in power amplifiers and linear regulators. This makes these switches highly efficient since there are lesser losses during the power processing.

### Power Diodes



A power diode has a P-I-N structure as compared to the signal diode having a P-N structure. Here, I (in P-I-N) stands for intrinsic semiconductor layer to bear the high-level reverse voltage as compared to the signal diode ( $n^-$ , drift region layer shown in Fig. 2). However, the drawback of this intrinsic layer is that it adds noticeable resistance during forward-biased condition. Thus, power diode requires a proper cooling arrangement for handling large power dissipation. Power diodes are used in numerous applications including rectifier, voltage clamper, voltage multiplier and etc. Power diode symbol is the same as of the signal diode as shown in Fig.1.

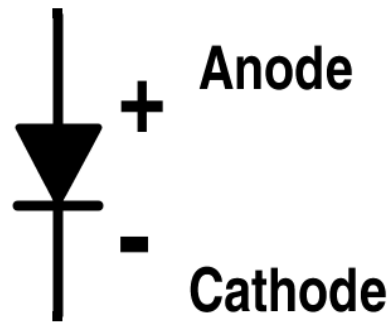


Figure 1. Symbol for Power Diode

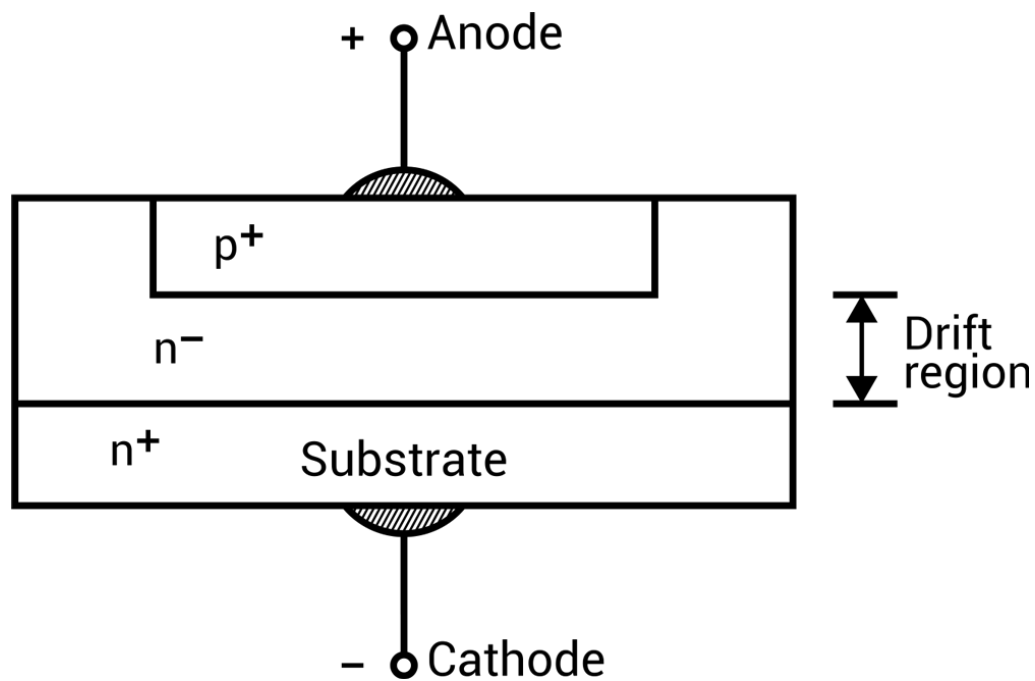


Figure 2. Structure of Power Diode

Other features that are incorporated in the power diode letting it handle larger power are:

- (a) Use of guard rings
- (b) Coating of Silicon Dioxide layer

Guard rings are of p-type that prevents their depletion layer merge with the depletion layer of the reverse-biased p-n junction. The guard rings prevent the radius of the curvature of the depletion layer boundary to become too narrow which increases the breakdown strength. Coating of  $\text{SiO}_2$  layer helps in limiting the electric field at the surface of the power diode.

If thickness of lightly doped I layer (n- layer) > depletion layer width at breakdown  $\Rightarrow$  Non-punch through power diode.

(This means depletion layer has not punched through the lightly-doped n-layer.)

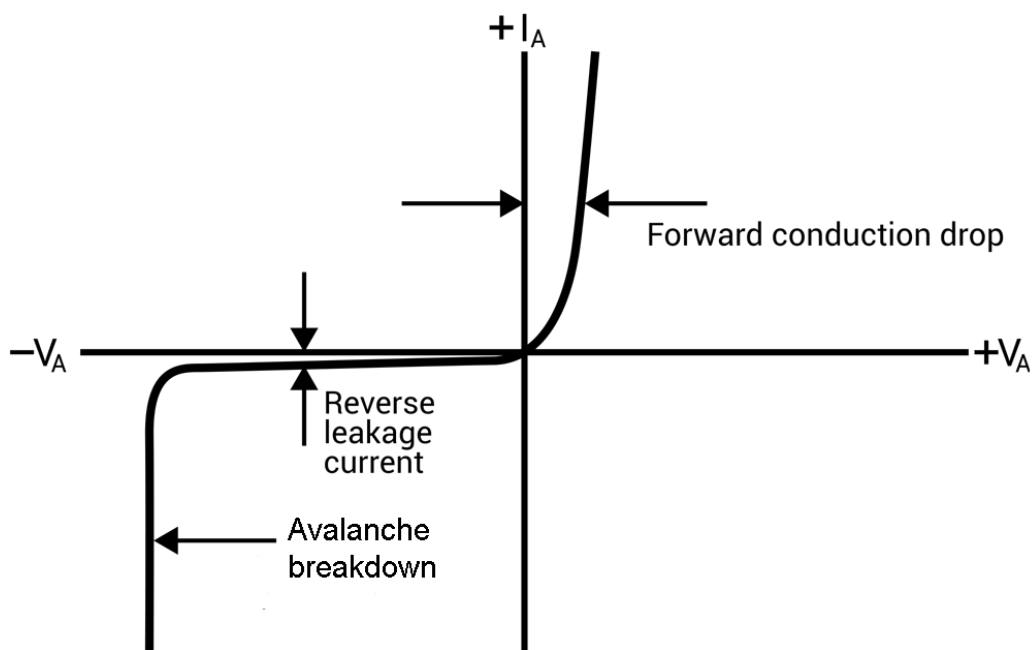
If thickness of I layer < depletion layer width at breakdown  $\Rightarrow$  Punch through power diode.

### Characteristics of Power Diode

The two types of characteristics of a power diode are shown in Fig. 3 and Fig. 4 named as follows:

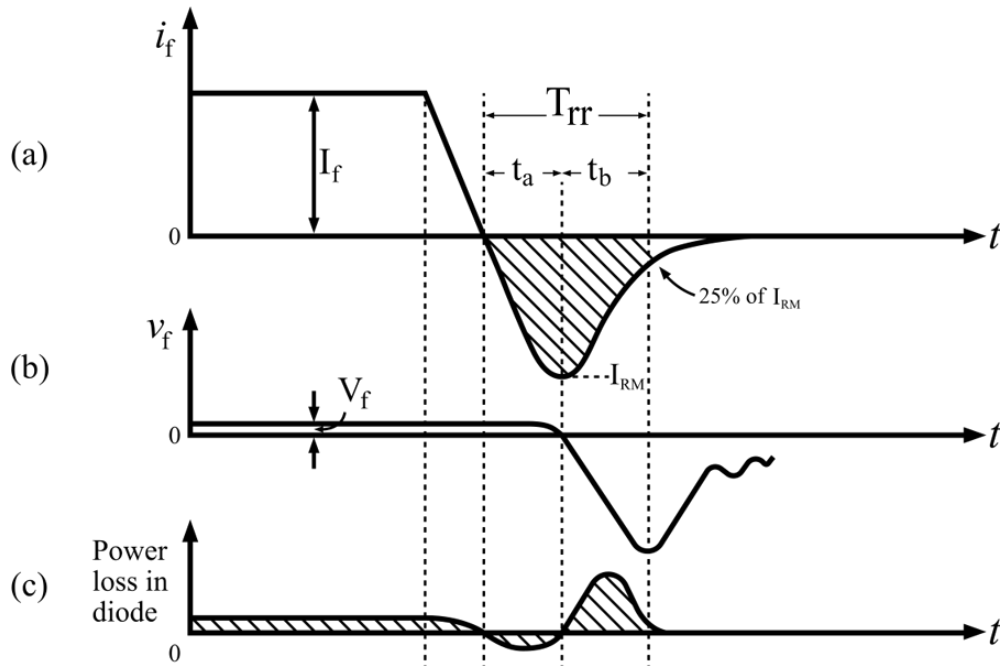
(i) Amp-volt characteristics (*i-v characteristics*)

(ii) Turn-off characteristics (*or reverse-recovery characteristics*)



**Figure 3. Amp-Volt Characteristics of Power Diode**

Cut-in voltage is the value of the minimum voltage for  $V_A$  (anode voltage) to make the diode works in forward conducting mode. Cut-in voltage of signal diode is 0.7 V while in power diode it is 1 V. So, its typical forward conduction drop is larger. Under forward-bias condition, signal diode current increases exponentially and then increases linearly. In the case of the power diode, it almost increases linearly with the applied voltage as all the layers of P-I-N remain saturated with minority carriers under forward bias. Thus, a high value of current produces results in voltage drop which mask the exponential part of the curve. In reverse-bias condition, small leakage current flows due to minority carriers until the avalanche breakdown appears as shown in Fig. 3.



**Figure 4. Turn-Off Characteristics of Power Diode: a) Variation of Forward Current  $i_f$  ; b) Variation of Forward Voltage Drop  $v_f$  ; c) Variation of Power Loss**

After the forward diode comes to null, the diode continues to conduct in the opposite direction because of the presence of stored charges in the depletion layer and the p or n-layer. The diode current flows for a reverse-recovery time  $t_{rr}$ . It is the time between the instant forward diode current becomes zero and the instant reverse-recovery current decays to 25 % of its reverse maximum value.

Time  $T_a$ : Charges stored in the depletion layer removed.

Time  $T_b$ : Charges from the semiconductor layer is removed.

Shaded area in Fig 4.a represents stored charges  $Q_R$  which must be removed during reverse-recovery time  $t_{rr}$ .

Power loss across diode =  $v_f \cdot i_f$  (shown in Fig. 4.c)

As shown, major power loss in the diode occurs during the period  $t_b$ .

Recovery can be abrupt or smooth as shown in Fig. 5. To know it quantitatively, we can use the S – factor.

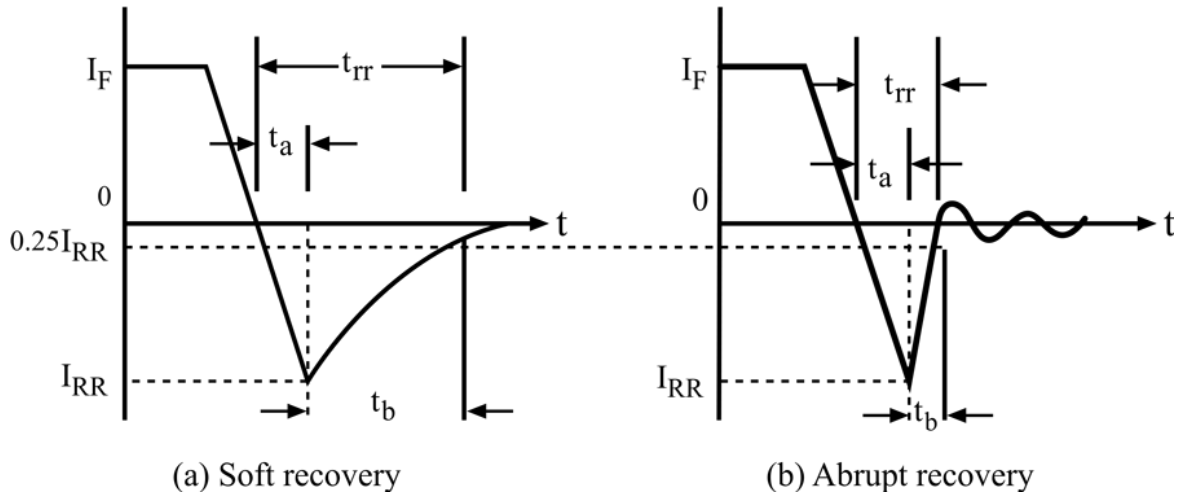
Ratio  $T_b/T_a$ : Softness factor or S-factor.

S-factor: measure of the voltage transient that occurs during the time the diode recovers.

S-factor = 1  $\Rightarrow$  low oscillatory reverse-recovery process. (Soft –recovery diode)

S-factor <1  $\Rightarrow$  large oscillatory over voltage (snappy-recovery diode or fast-recovery diode).

Power diodes now exist with forward current rating of 1A to several thousand amperes with reverse-recovery voltage ratings of 50V to 5000V or more.

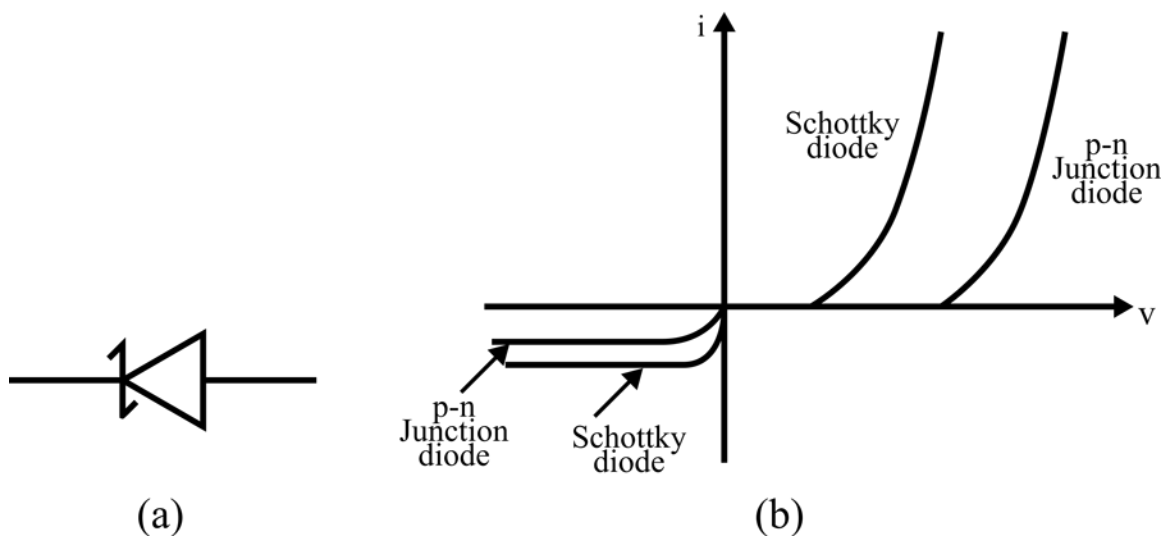


**Figure 5. Reverse-Recovery Characteristics for Power Diode**

Schottky Diode: It has an aluminum-silicon junction where the silicon is an n-type. As the metal has no holes, there is no stored charge and no reverse-recovery time. Therefore, there is only the movement of the majority carriers (electrons) and the turn-off delay caused by recombination process is avoided. It can also switch off much faster than a p-n junction diode. As compared to the p-n junction diode it has:

- (a) Lower cut-in voltage
- (b) Higher reverse leakage current
- (c) Higher operating frequency

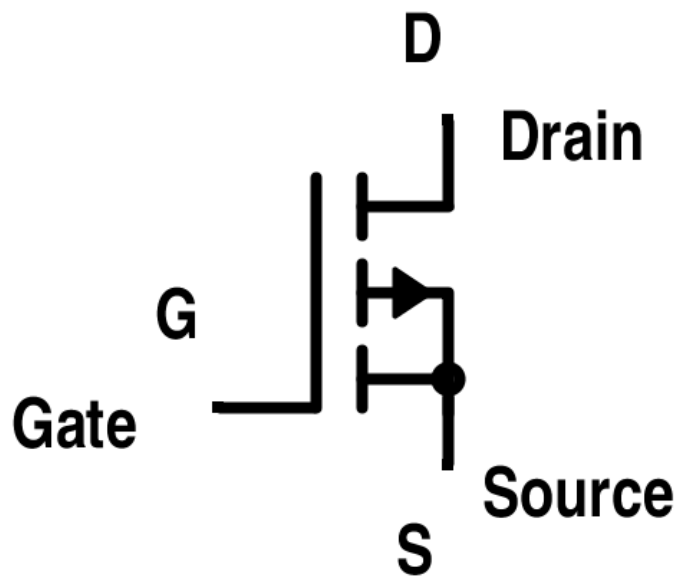
Application: high-frequency instrumentation and switching power supplies.



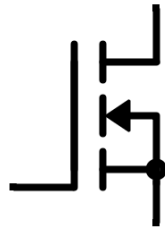
**Figure 6. Schottky Diode Symbol and Current-Voltage Characteristics Curve**

### **Metal-Oxide Semiconductor Field-Effect Transistor (MOSFET)**

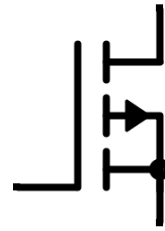
MOSFET is a voltage-controlled majority carrier (or unipolar) three-terminal device. Its symbols are shown in Fig. 7 and Fig. 8. As compared to the simple lateral channel MOSFET for low-power signals, power MOSFET has different structure. It has a vertical channel structure where the source and the drain are on the opposite side of the silicon wafer as shown in Fig. 10. This opposite placement of the source and the drain increases the capability of the power MOSFET to handle larger power.



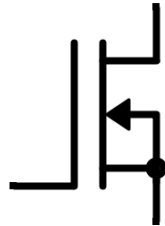
**Figure 7. MOSFET Symbol**



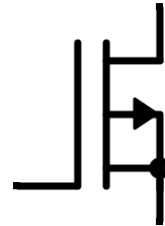
**MOSFET: N-Channel  
Enhancement Type**



**MOSFET: P-Channel  
Enhancement Type**



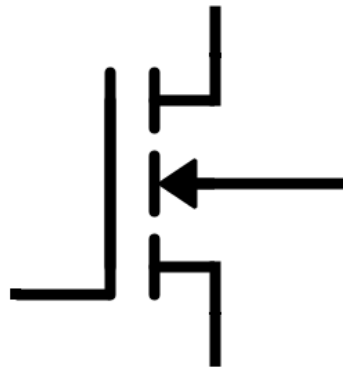
**MOSFET: N-Channel  
Depletion Type**



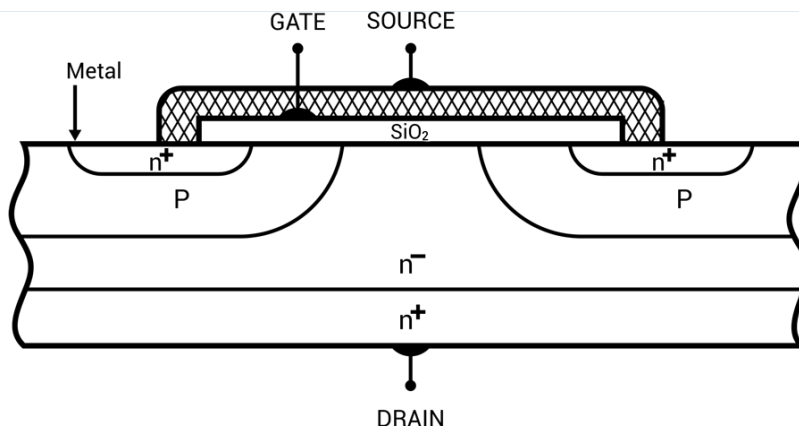
**MOSFET: P-Channel  
Depletion Type**

**Figure 8. MOSFET Symbols for Different Modes**

In all of these connections, substrates are internally connected. But in cases where it is connected externally, the symbol will change as shown in the n-channel enhancement type MOSFET in Fig. 9. N-channel enhancement type MOSFET is more common due to high mobility of electrons.

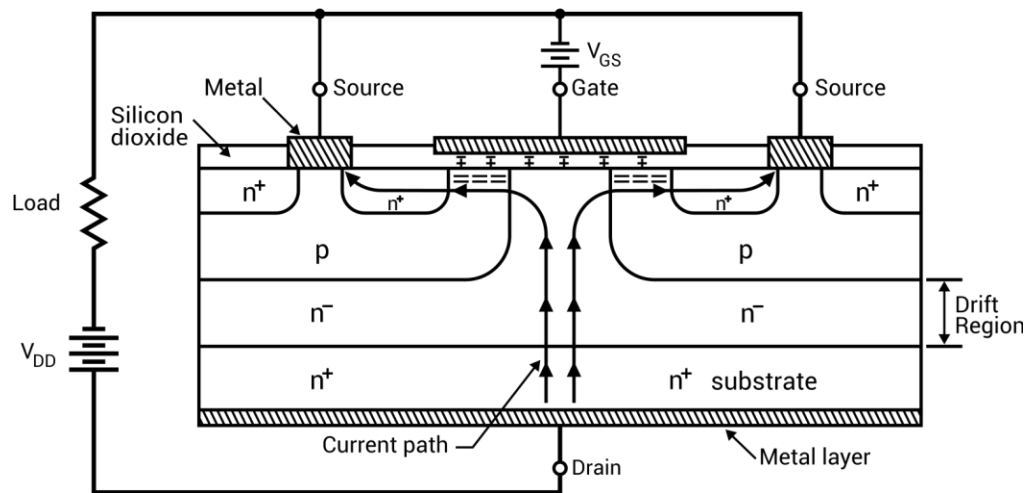


**Figure 9. N-channel Enhancement-Type MOSFET with Substrate Connected Externally**



**Figure 10. Cross-Sectional View of the Power MOSFET**

Basic circuit diagram and output characteristics of an n-channel enhancement power MOSFET with load connected are in Fig. 11 and Fig. 12 respectively.



**Figure 11. Power MOSFET Structural View with Connections**

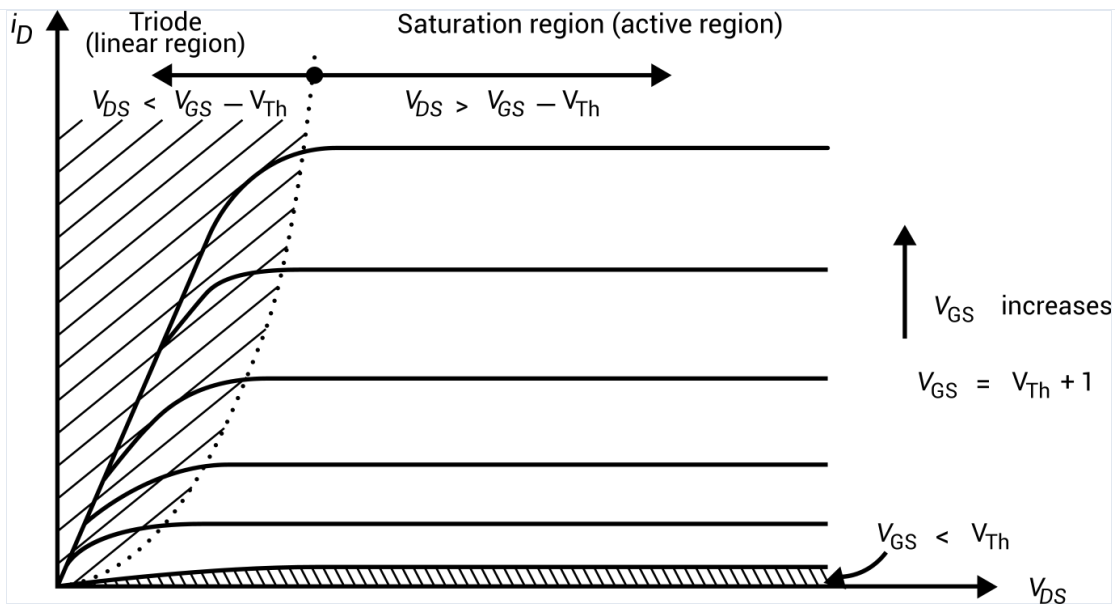
Drift region shown in Fig. 11 determines the voltage-blocking capability of the MOSFET.

When  $V_{GS} = 0$ ,

⇒  $V_{DD}$  makes it reverse biased and no current flows from drain to source.

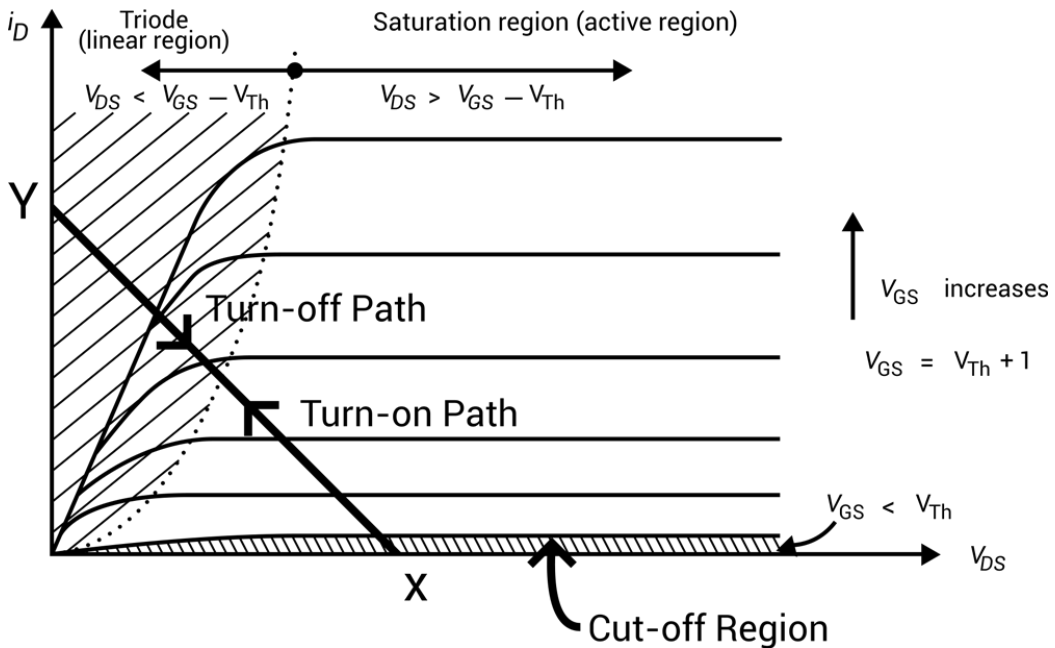
When  $V_{GS} > 0$ ,

⇒ Electrons form the current path as shown in Fig. 11. Thus, current from the drain to the source flows. Now, if we will increase the gate-to-source voltage, drain current will also increase.



**Figure 12. Drain Current ( $i_D$ ) vs Drain-to-Source Voltage ( $V_{DS}$ ) Characteristics Curves**

For lower value of  $V_{DS}$ , MOSFET works in a linear region where it has a constant resistance equal to  $V_{DS} / i_D$ . For a fixed value of  $V_{GS}$  and greater than threshold voltage  $V_{Th}$ , MOSFET enters a saturation region where the value of the drain current has a fixed value.

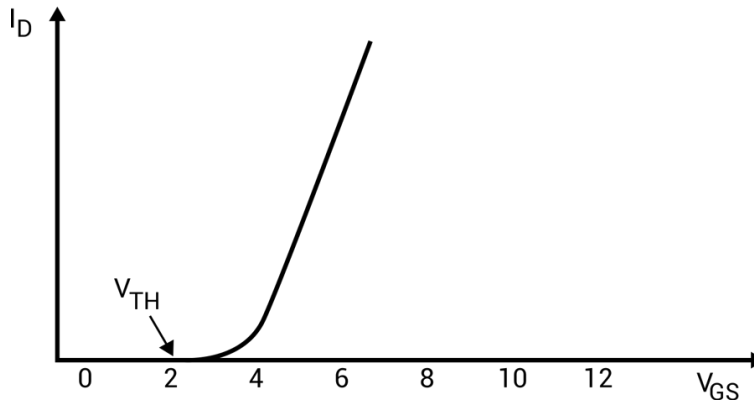


**Figure 13. Output Characteristics with Load Line**

If XY represents the load line, then the X-point represents the turn-off point and Y-point is the turn-on point where  $V_{DS} = 0$  (as voltage across the closed switch is zero). The direction of turning on and turning off process is also shown in Fig. 13.



Besides the output characteristics curves, transfer characteristics of power MOSFET is also shown in Fig. 14.

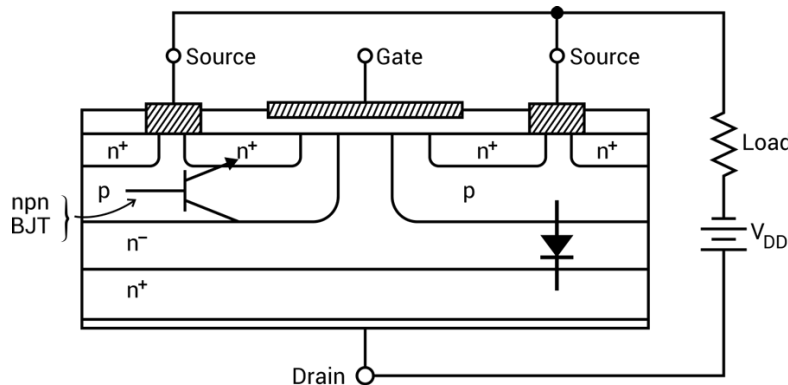


**Figure 14. Gate-to-Source Voltage vs. Drain Current Characteristics for Power MOSFET**

Here,  $V_{TH}$  is the minimum positive voltage between gate and the source above which MOSFET comes in on-state from the off-state. This is called threshold voltage. It is also shown in the output characteristics curve in Fig. 12.

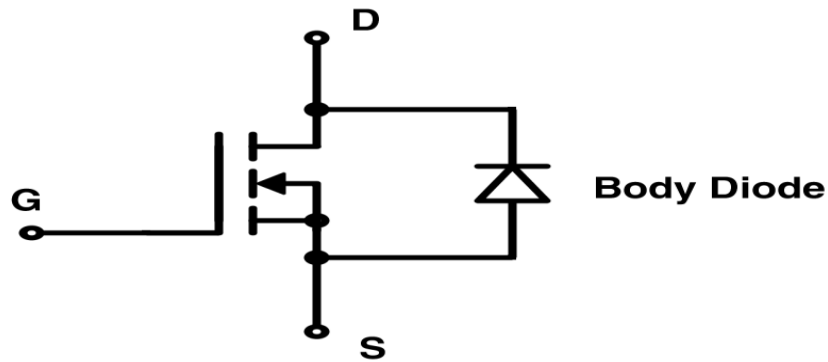
Close view of the structural diagram given in Fig. 11 reveals that there exists a fictitious BJT and a fictitious diode structure embedded in the power MOSFET as shown in Fig. 15.

As source is connected to both base and emitter of this parasitic BJT, emitter and base of the BJT are short circuited. That means this BJT acts in cut-off state.



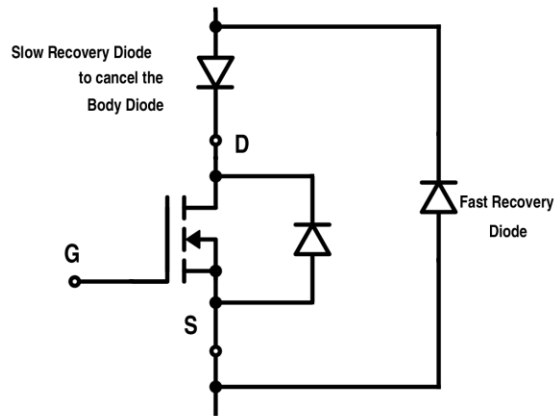
**Figure 15. Fictitious BJT and Fictitious Diode in the Power MOSFET**

Fictitious diode anode is connected to the source and its cathode is connected to the drain. So, if we apply the negative voltage  $V_{DD}$  across the drain and source, it will be forward biased. That means, the reverse-blocking capability of the MOSFET breaks. Thus, this can be used in inverter circuit for reactive loads without the need of excessive diode across a switch. Symbolically, it is represented in Fig. 16.



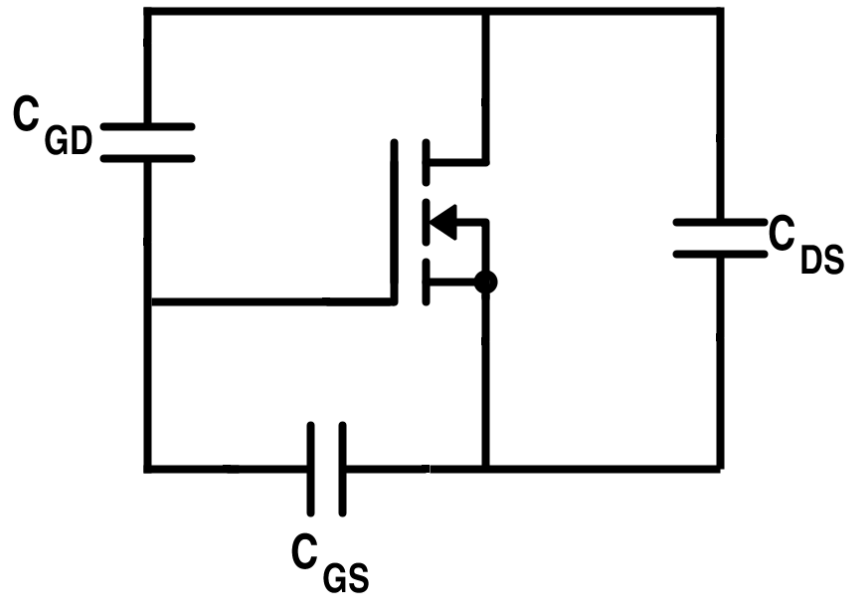
**Figure 16. MOSFET Representation with Internal Body Diode**

Although MOSFET internal body diode has sufficient current and switching speed for most of the applications, there may be some applications where the use of ultra-fast diodes is required. In such cases, an external fast-recovery diode is connected in an antiparallel manner. But a slow-recovery diode is also required to block the body diode action as given in Fig. 17.



**Figure 17. Implementation of Fast-Recovery Diode for Power MOSFET**

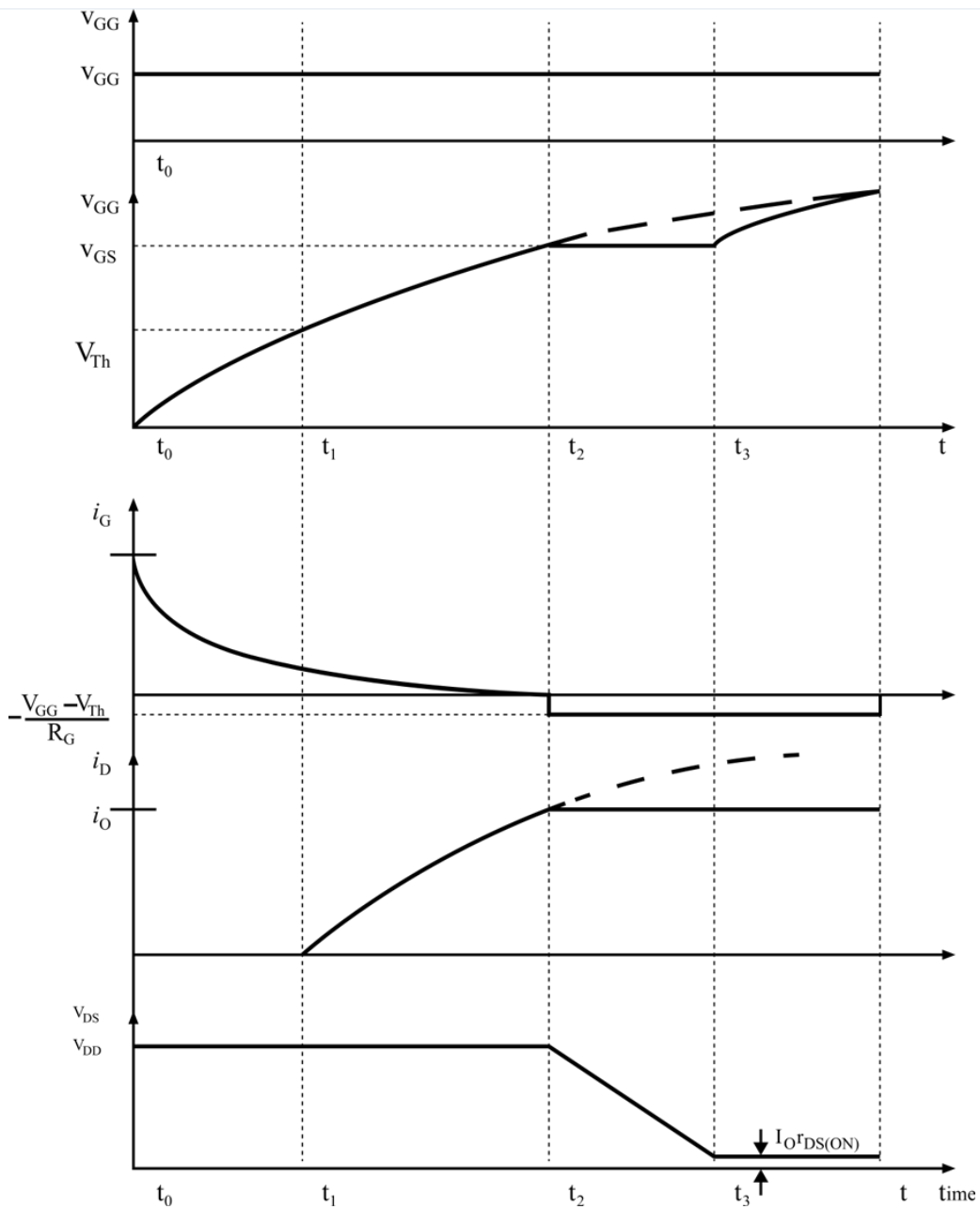
One of the important parameters that affects the switching characteristics is the body capacitances existing between its three terminals i.e. drain, source and gate. Its representation is shown in Fig. 18.



**Figure 18. MOSFET Representation Showing Junction Capacitances**

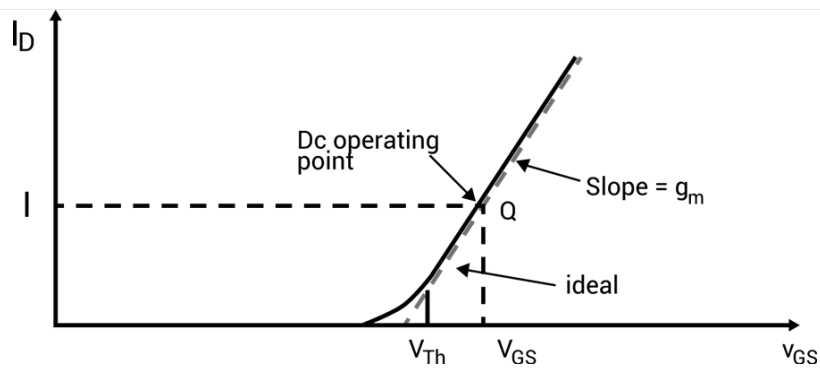
Parameters  $C_{GS}$ ,  $C_{GD}$  and  $C_{DS}$  are all non-linear in nature and given in the device's data sheet of a particular MOSFET. They also depend on the DC bias voltage and the device's structure or geometry. They must be charged through gate during turn-on process to actually turn on the MOSFET. The drive must be capable of charging and discharging these capacitances to switch on or switch off the MOSFET.

Thus, the switching characteristics of a power MOSFET depend on these internal capacitances and the internal impedance of the gate drive circuits. Also, it depends on the delay due to the carrier transport through the drift region. Switching characteristics of power MOSFET are shown in Fig. 19 and Fig. 20.



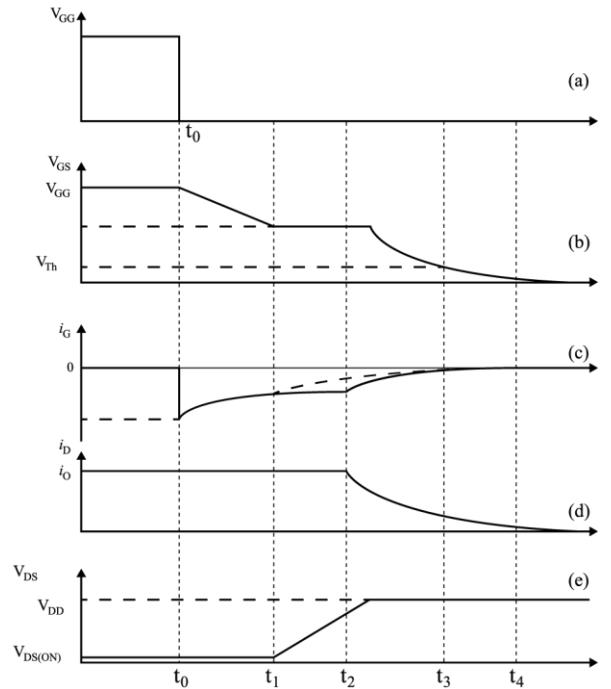
**Figure 19. Turn-on Characteristics of Power MOSFET**

There is a delay from  $t_0$  to  $t_1$  due to charging of input capacitance up to its threshold voltage  $V_{TH}$ . Drain current in this duration remains at zero value. This is called a delay time. There is a further delay from  $t_1$  to  $t_2$  during which the gate voltage rises to  $V_{GS}$ , a voltage required to drive the MOSFET into on-state. This is called the rise time. This total delay can be reduced by using a low-impedance drive circuit. The gate current during this duration decreases exponentially as shown. For the time greater than  $t_2$ , the drain current  $I_D$  has reached its maximum constant value  $I$ . As drain current has reached the constant value, the gate-to-source voltage is also constant as shown in the transfer characteristics of MOSFET in Fig. 20.



**Figure 20. Transfer Characteristics of Power MOSFET with Operating Point**

For turn-off characteristics, assume that the MOSFET is already in the switched-on situation with steady state. As  $t = t_0$ , gate voltage is reduced to zero value;  $C_{GS}$  and  $C_{GD}$  start to discharge through gate resistance  $R_G$ . This causes a turn-off delay time up to  $t_1$  from  $t_0$  as shown in Fig. 21. Assuming the drain-to-source voltage remains fixed. During this duration, both  $V_{GS}$  and  $I_G$  decreases in magnitude, drain current remains at a fixed value drawing current from  $C_{GD}$  and  $C_{GS}$ .

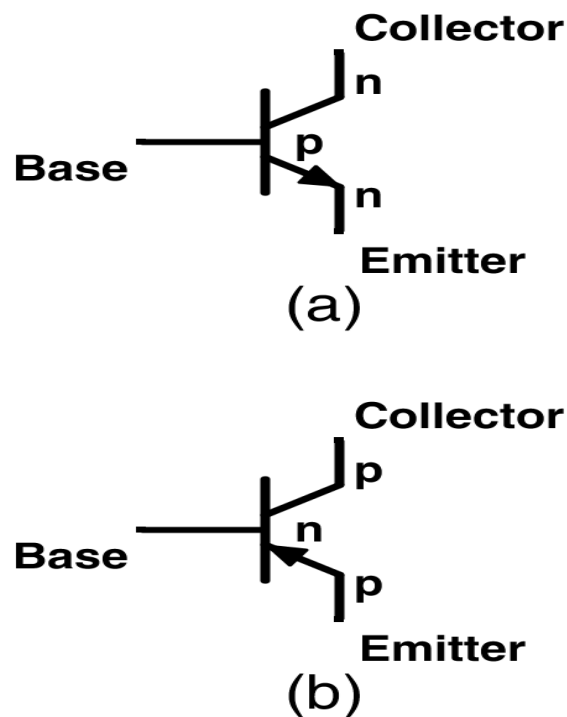


**Figure 21. Turn-Off Characteristics of Power MOSFET**

For the time where  $t_2 > t > t_1$ , gate-to-source voltage is constant. Thus, the entire current is now being drawn from  $C_{GD}$ . Up to time  $t_3$ , the drain current will almost reach zero value; which turns off the MOSFET. This time is known as the fall time, this is when the input capacitance discharges up to the threshold value. Beyond  $t_3$ , gate voltage decreases exponentially to zero until the gate current becomes zero.

### Power Bipolar Junction Transistor (BJT)

Power BJT is used traditionally for many applications. However, IGBT (Insulated-Gate Bipolar Transistor) and MOSFET (Metal-Oxide-Semiconductor Field-Effect Transistor) have replaced it for most of the applications but still they are used in some areas due to its lower saturation voltage over the operating temperature range. IGBT and MOSFET have higher input capacitance as compared to BJT. Thus, in case of IGBT and MOSFET, drive circuit must be capable to charge and discharge the internal capacitances.

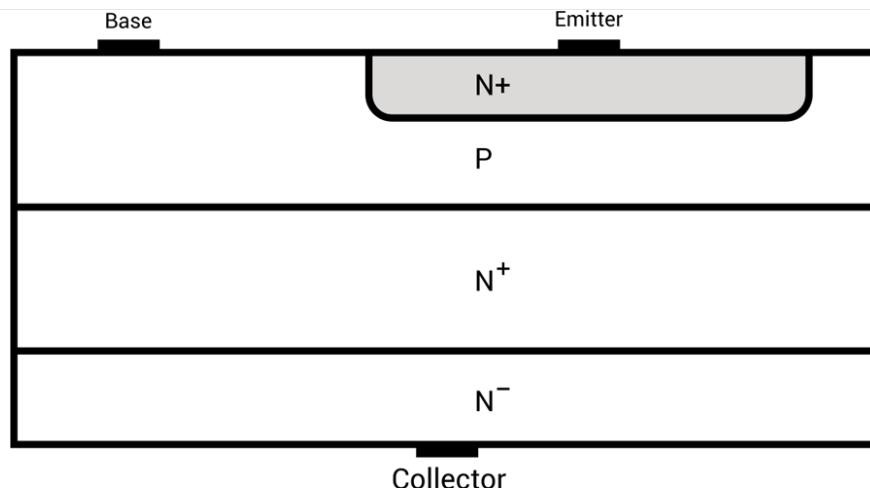


**Figure 22. (a) NPN BJT (b) PNP BJT**

The BJT is a three-layer and two-junction npn or pnp semiconductor device as given in Fig. 22. (a) and (b).

Although BJTs have lower input capacitance as compared to MOSFET or IGBT, BJTs are considerably slower in response due to low input impedance. BJTs use more silicon for the same drive performance.

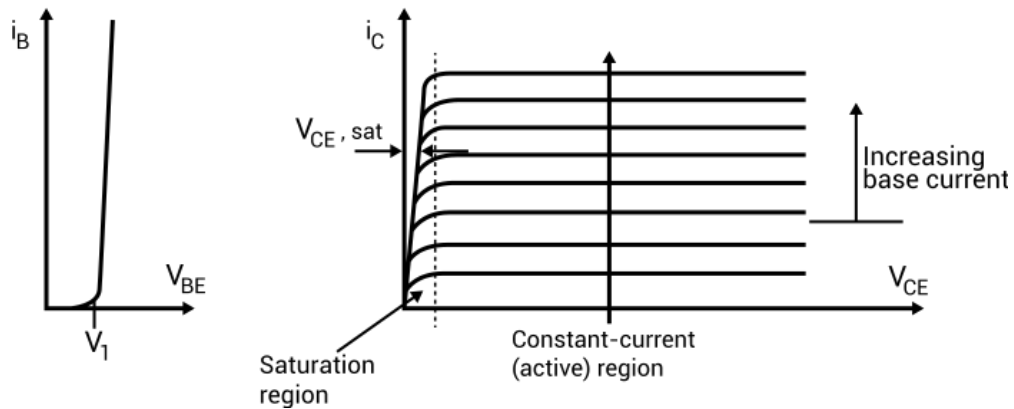
In the case of MOSFET studied earlier, power BJT is different in configuration as compared to simple planar BJT. In planar BJT, collector and emitter is on the same side of the wafer while in power BJT it is on the opposite edges as shown in Fig. 23. This is done to increase the power-handling capability of BJT.



**Figure 23. Power BJT PNP Structure**

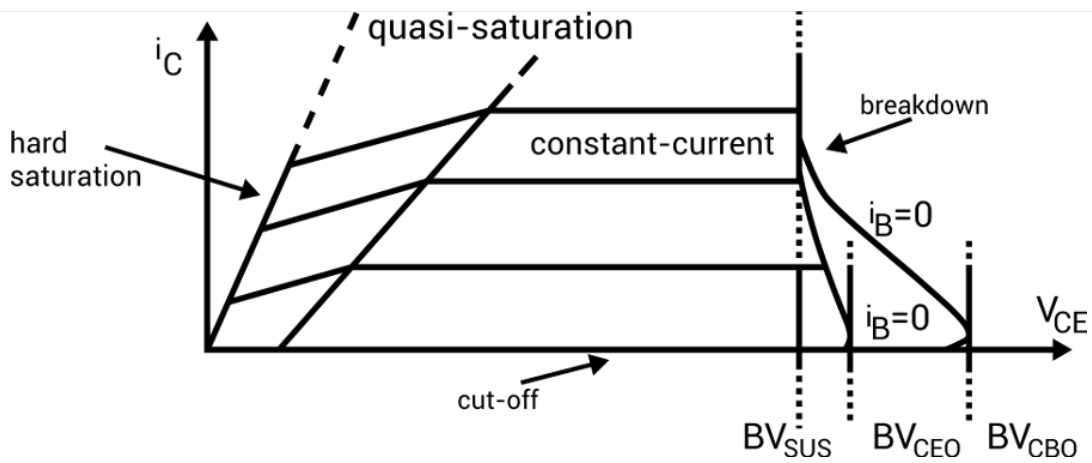
Power n-p-n transistors are widely used in high-voltage and high-current applications which will be discussed later.

Input and output characteristics of planar BJT for common-emitter configuration are shown in Fig. 24. These are current-voltage characteristics curves.



**Figure 24. Input Characteristics and Output Characteristics for the Common-Emitter Configuration of Planar BJT respectively**

Characteristic curves for power BJT is just the same except for the little difference in its saturation region. It has additional region of operation known as quasi-saturation as shown in Fig. 25.



**Figure 25. Power BJT Output Characteristics Curve**

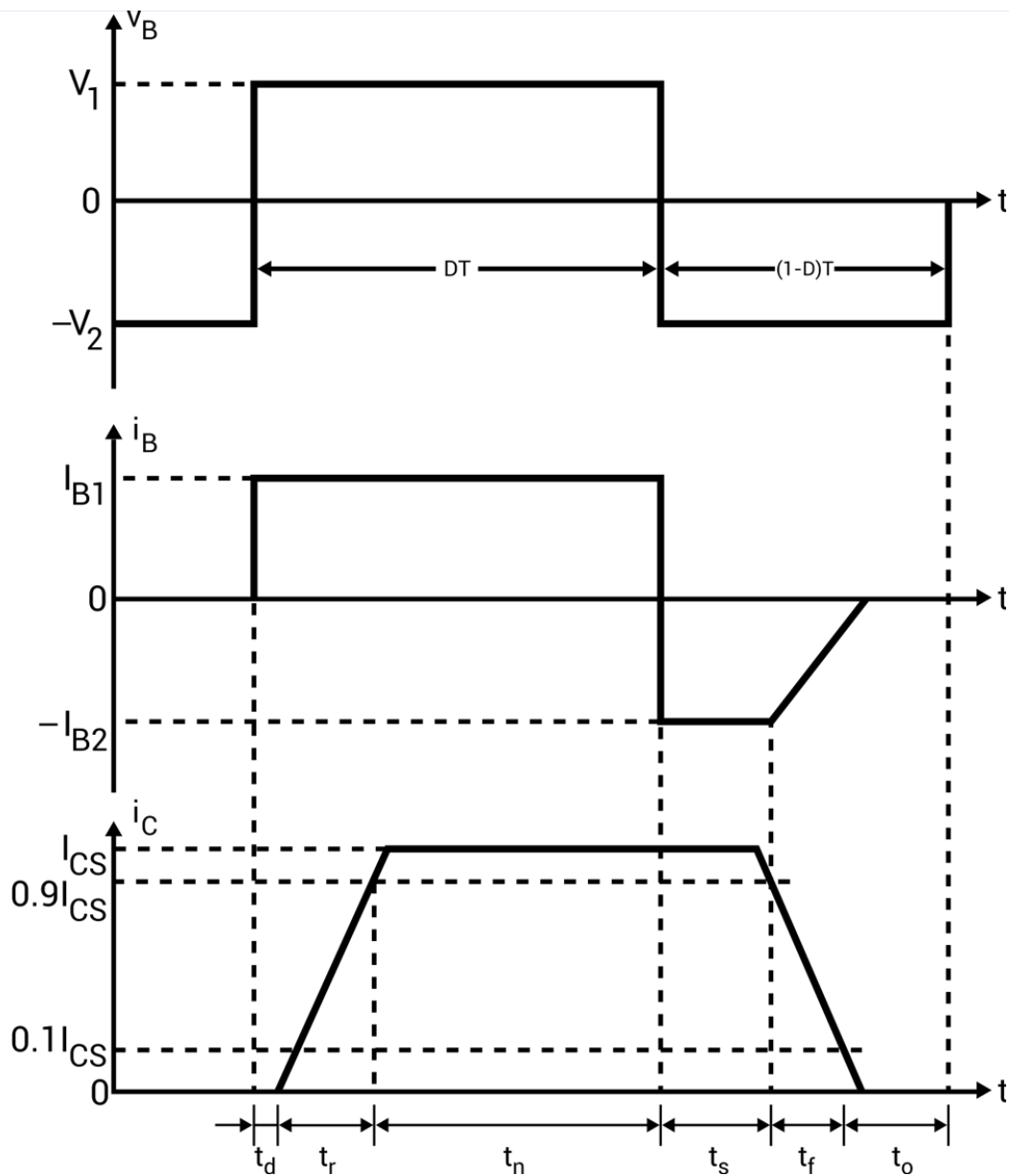
This region appears due to the insertion of lightly-doped collector drift region where the collector base junction has a low reverse bias. The resistivity of this drift region is dependent on the value of the base current. In the quasi-saturation region, the value of  $\beta$  decreases significantly. This is due to the increased value of the collector current with increased temperature. But the base current still has the control over the collector current due to the resistance offered by the drift region. If the transistor enters in hard saturation region, base current has no control over the collector current due to the absence of the drift region and mainly depends on the load and the value of  $V_{CC}$ .

A forward-biased p-n junction has two capacitances named depletion layer capacitance and diffused capacitance. While a reverse bias junction has only a depletion capacitance in action. Value of these capacitances depends on the junction voltage and construction of the transistor. These capacitances come into role during the transient operation i.e. switching operations. Due to these capacitances, transistor does not turn on or turn off instantly.

Switching characteristics of power BJT is shown in Fig.26. As the positive base voltage is applied, base current starts to flow but there is no collector current for some time. This time is known as the **delay time** ( $t_d$ ) required to charge the junction capacitance of the base to emitter to 0.7 V approx. (known as forward-bias voltage). For  $t > t_d$ , collector current starts rising and  $V_{CE}$  starts to drop with the magnitude of 9/10th of its peak value. This time is called **rise time**, required to turn on the transistor. The transistor remains on so long as the collector current is at least of this value.

For turning off the BJT, polarity of the base voltage is reversed and thus the base current polarity will also be changed as shown in Fig. 26. The base current required during the steady-state operation is more than that required to saturate the transistor. Thus, excess minority carrier charges are stored in the base region which needs to be removed during the turn-off process. The time required to nullify this charge is the **storage time**,  $t_s$ . Collector current remains at the same value for this time. After this, collector current starts decreasing and base-to-emitter junction charges to the negative polarity; base current also get reduced.

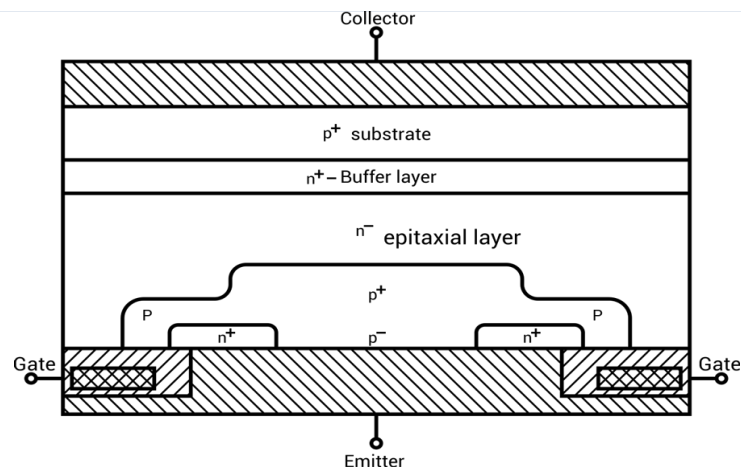




**Figure 26. Turn-On and Turn-Off Characteristics of BJT**

### **Insulated-Gate Bipolar Transistor (IGBT)**

IGBT combines the physics of both BJT and power MOSFET to gain the advantages of both worlds. It is controlled by the gate voltage. It has the high input impedance like a power MOSFET and has low on-state power loss as in case of BJT. There is no even secondary breakdown and not have long switching time as in case of BJT. It has better conduction characteristics as compared to MOSFET due to bipolar nature. It has no body diode as in case of MOSFET but this can be seen as an advantage to use external fast recovery diode for specific applications. They are replacing the MOSFET for most of the high voltage applications with less conduction losses. Its physical cross-sectional structural diagram and equivalent circuit diagram is presented in Fig. 27 to Fig. 29. It has three terminals called collector, emitter and gate.



**Figure 27. IGBT Structure View**

There is a p+ substrate which is not present in the MOSFET and responsible for the minority carrier injection into the n-region. Gain of NPN terminal is reduced due to wide epitaxial base and n+ buffer layer.

There are two structures of IGBTs based on doping of buffer layer:

a) Punch-through IGBT: Heavily doped n buffer layer → less switching time

b) Non-Punch-through IGBT: Lightly doped n buffer layer → greater carrier lifetime → increased conductivity of drift region → reduced on-state voltage drop

(Note: → means implies)

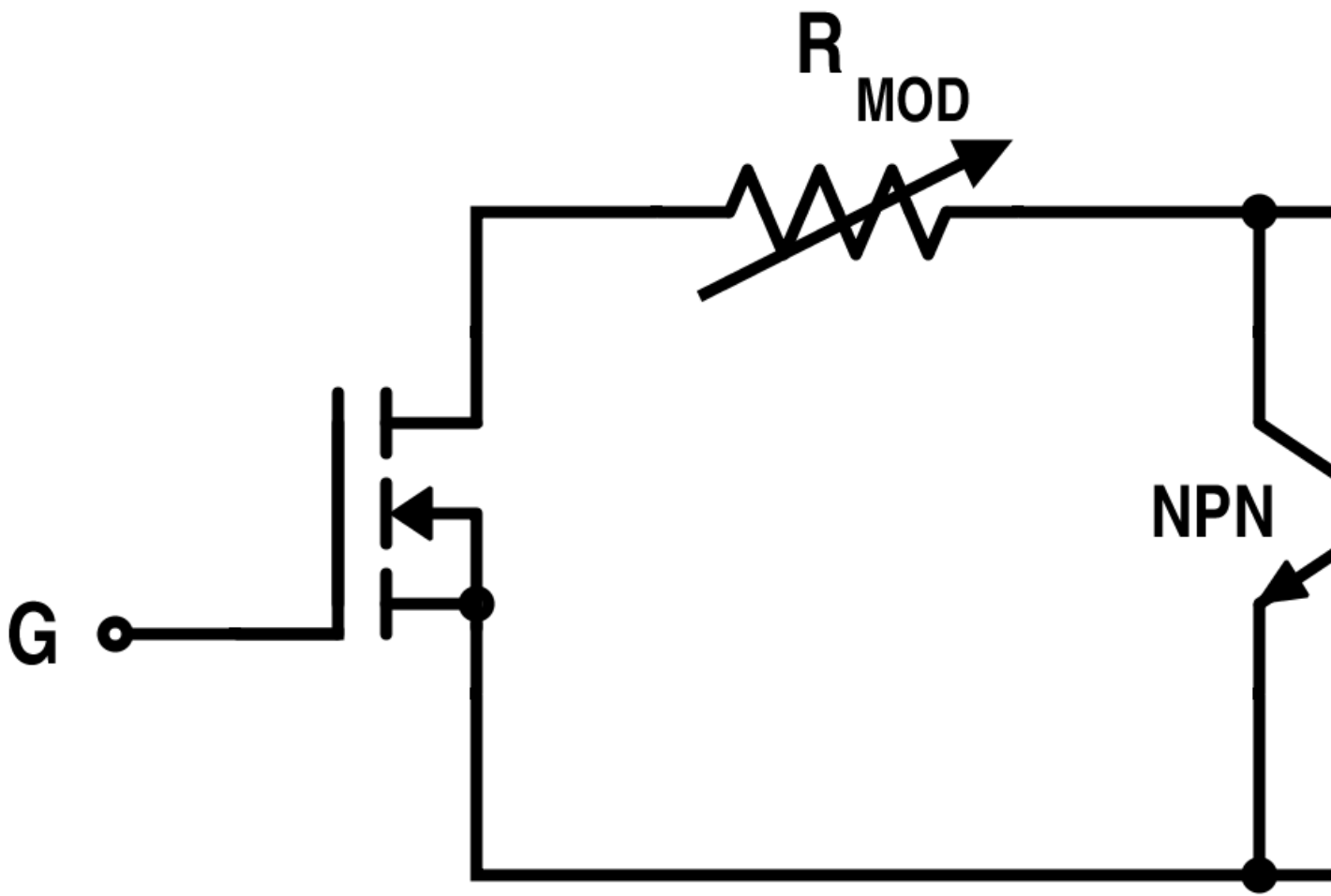


Figure 28. Equivalent Circuit for IGBT

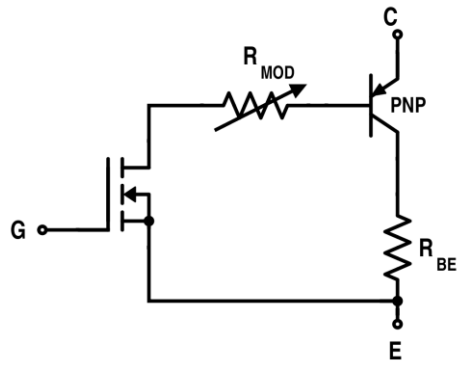


Figure 29. Simplified Equivalent Circuit for IGBT

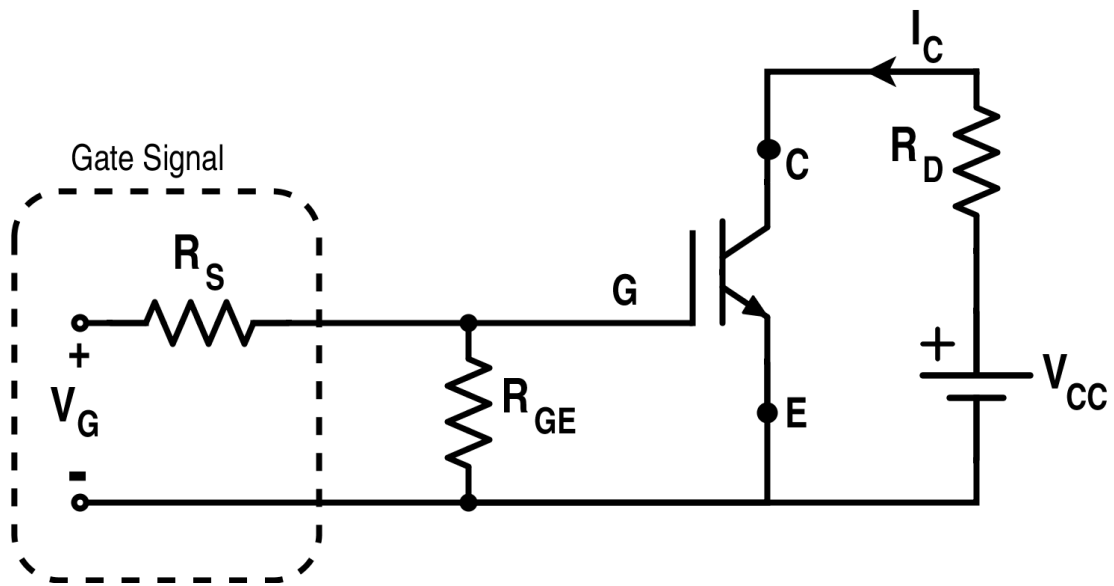
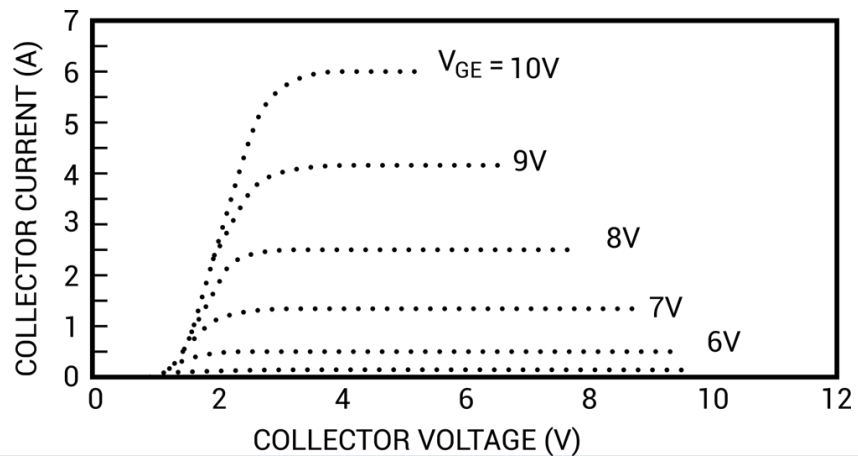
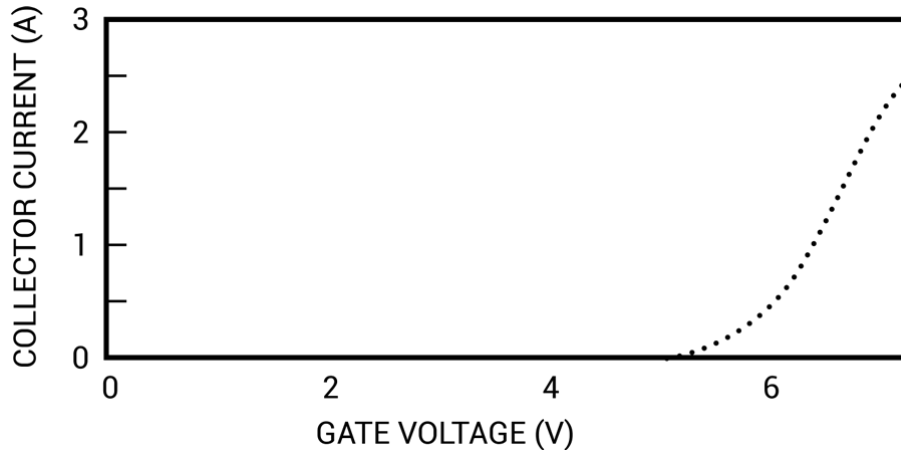


Figure 30. Circuit Diagram for IGBT

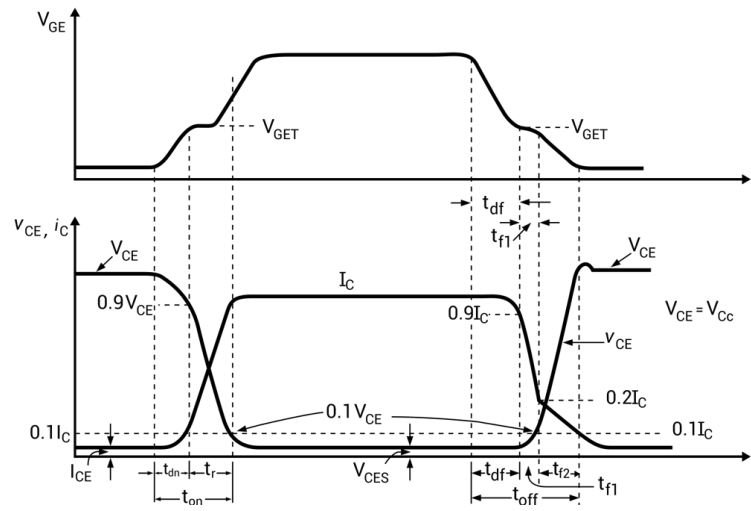
Based on this circuit diagram given in Fig.30, forward characteristics and transfer characteristics are obtained which are given in Fig.31 and Fig.32. Its switching characteristic is also shown in Fig. 33.



**Figure 31. Forward Characteristics for IGBT**



**Figure 32. Transfer Characteristics of IGBT**



**Figure 33. Turn-On and Turn-Off Characteristics of IGBT**

(Note:  $T_{dn}$ : delay time ;  $T_r$ : rise time ;  $T_{df}$ : delay time ;  $T_{f1}$ : initial fall time ;  $T_{f2}$ : final fall time)

### Thyristors (SCR, GTO, MCT)

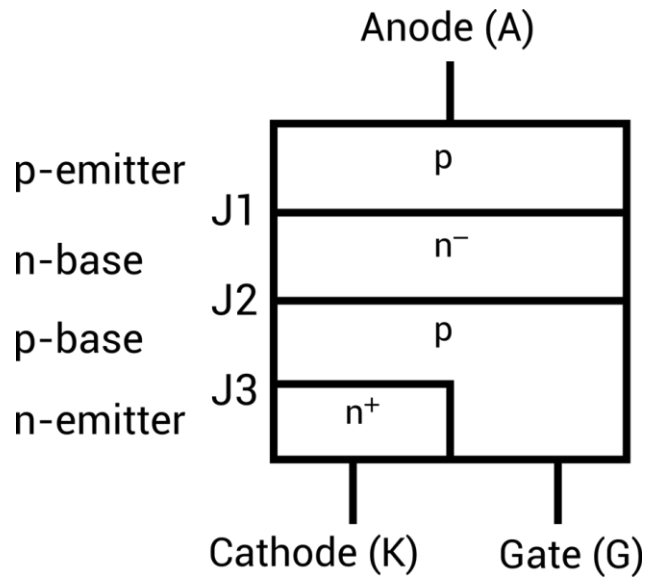
Thyristors are the family of solid-state devices extensively used in power electronics circuitry such as SCR (silicon-controlled rectifier), DIAC (diode on AC), TRIAC (triode on AC), GTO (gate turn-off thyristors), MCT (MOS-controlled thyristor), RCT, PUT, UJT, LASCR, LASCS, SIT, SITH, SIS, SBS, SUS, SBS and etc. SCR is the oldest member and the head of this family; and usually referred with the name "thyristor".

They are operated as bistable switches that are either working in non-conducting or conducting state. Traditional thyristors are designed without gate-controlled turn-off capability in which the thyristor can

come from conducting state to non-conducting state when only anode current falls below the holding current. While GTO is a type of thyristor that has a gate-controlled turn-off capability.

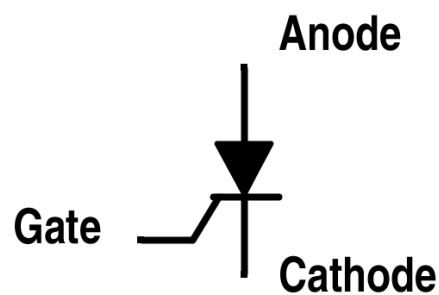
### SCR

SCR usually has three terminals and four layers of alternating p and n-type materials as shown in Fig. 34. The structure of the thyristor can be split into two sections: npn and pnp transistors for simple analysis purposes as shown in Fig. 36. It has three terminals named as cathode, anode and gate.

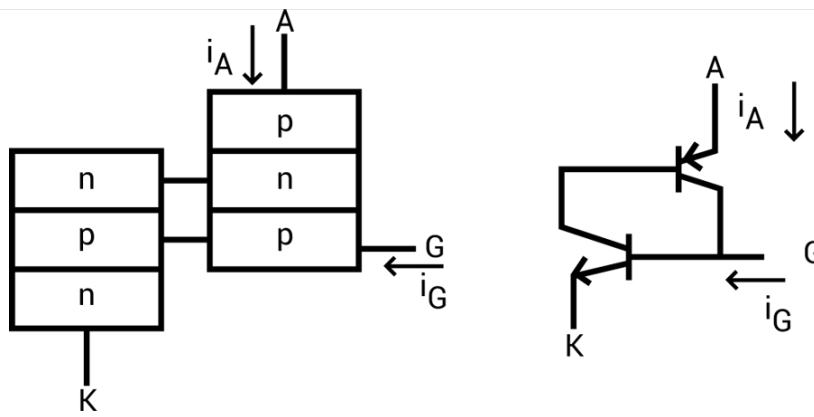


**Figure 34. Structural View of Thyristor**

N-base is a high-resistivity region and its thickness is directly dependent on the forward blocking rating of the thyristor. But more width of the n-base indicates a slow response time for switching. Symbol of thyristor is given in Fig. 35.



**Figure 35. Schematic Symbol of Thyristor**

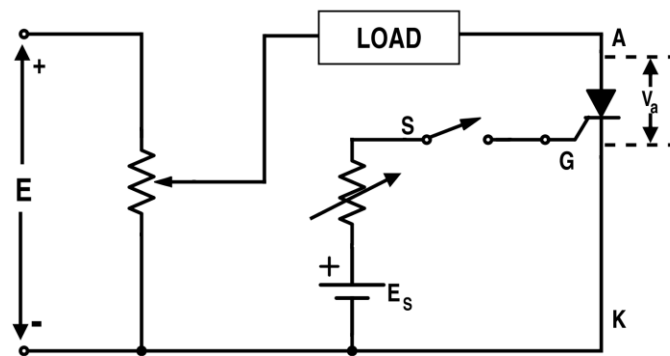


**Figure 36. Two-Transistor Model of a Thyristor (A-Anode, G-Gate and K-Cathode)**

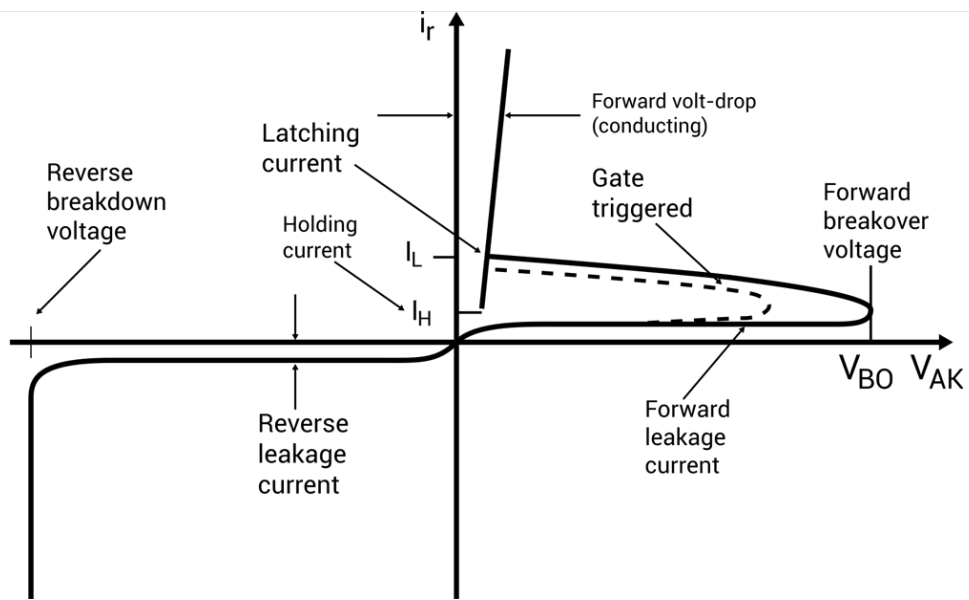
Planar construction is used for low-power SCRs. In this type of construction, all the junctions are diffused. For high power, mesa construction is used where the inner layer is diffused and the two outer layers are alloyed on it.

The static characteristic obtained from the circuit given in Fig. 37 is drawn in Fig. 38. It works under three modes: forward conducting mode, forward blocking mode and reverse blocking mode.

The minimum anode current that causes the device to stay at forward conduction mode as it switch from forward blocking mode is called the latching current. If the SCR is already conducting and the anode current is reduced from forward conducting mode to forward blocking mode, the minimum value of anode current to remain at the forward conducting mode is known as the holding current.



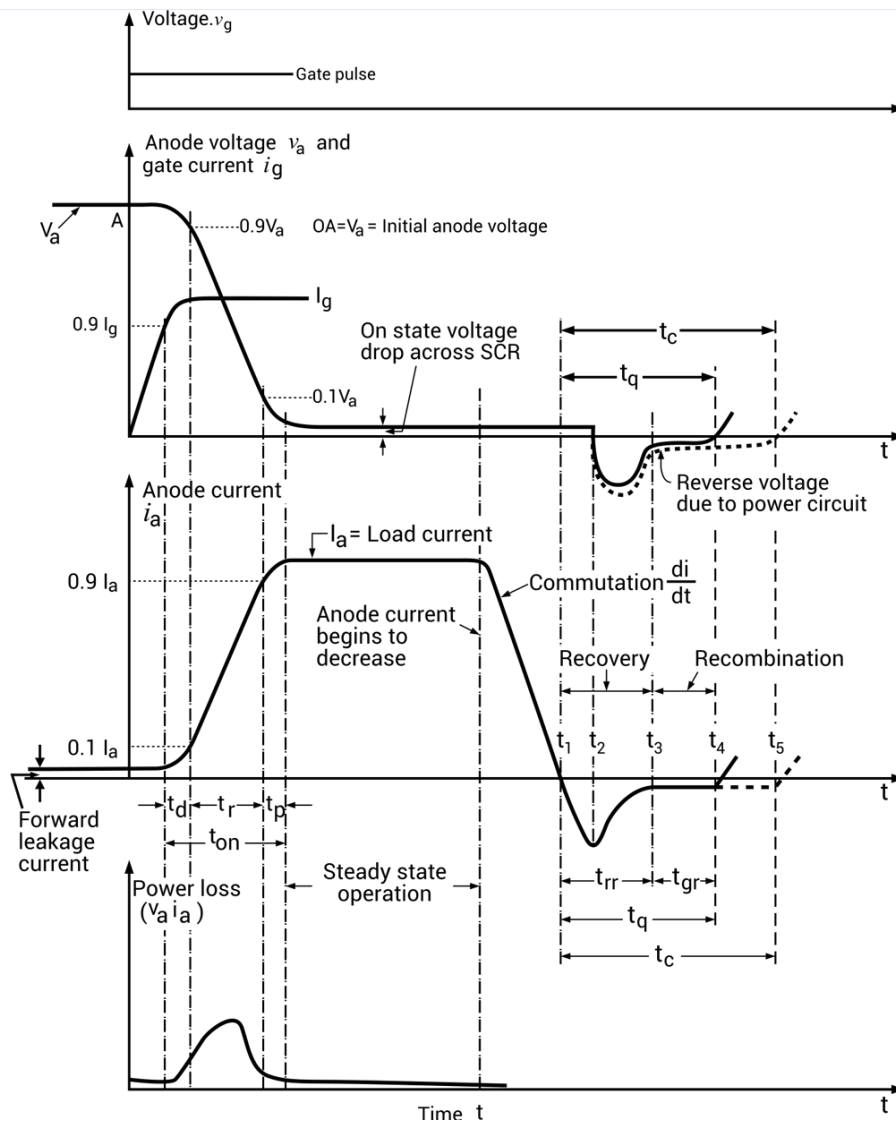
**Figure 37. Basic Circuit for Getting Voltage and Current Characteristics of Thyristor**



**Figure 38. Static Characteristics Curve of SCR**

Switching characteristics of SCR are shown in Fig. 39. Note that it can't be turned off with the gate. This is due to positive feedback or a regenerative feedback effect.





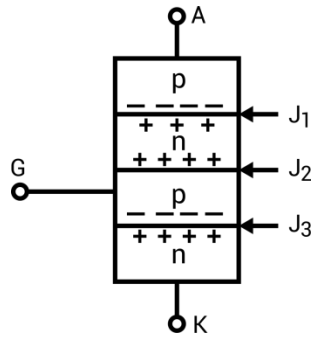
**Figure 39. Turn-On and Turn-Off Characteristics of SCR**

### GTO (Gate Turn-off Thyristor)

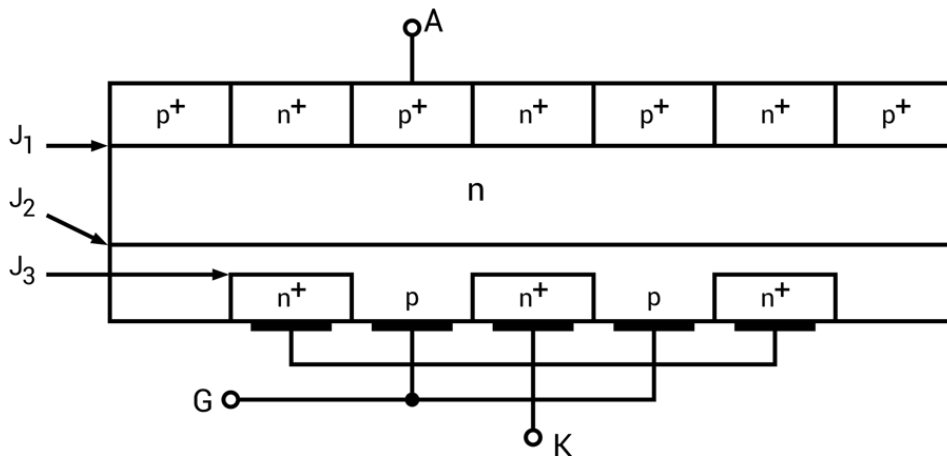
GTO can be turned on with the positive gate current pulse and turned off with the negative gate current pulse. Its capability to turn off is due to the diversion of PNP collector current by the gate and thus breaking the regenerative feedback effect.

Actually the design of GTO is made in such a way that the pnp current gain of GTO is reduced. Highly doped n spots in the anode p layer form a shorted emitter effect and ultimately decreases the current gain of GTO for lower current regeneration and also the reverse voltage blocking capability. This reduction in reverse blocking capability can be improved by diffusing gold but this reduces the carrier lifetime. Moreover, it requires a special protection as shown in Fig. 43.

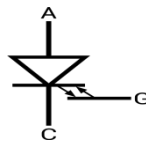
Fig. 40 shows the four Si layers and the three junctions of GTO and Fig. 41 shows its practical form. The symbol for GTO is shown in Fig.42.



**Figure 40. Four Layers and Three Junctions of GTO**



**Figure 41. Practical Form of GTO**

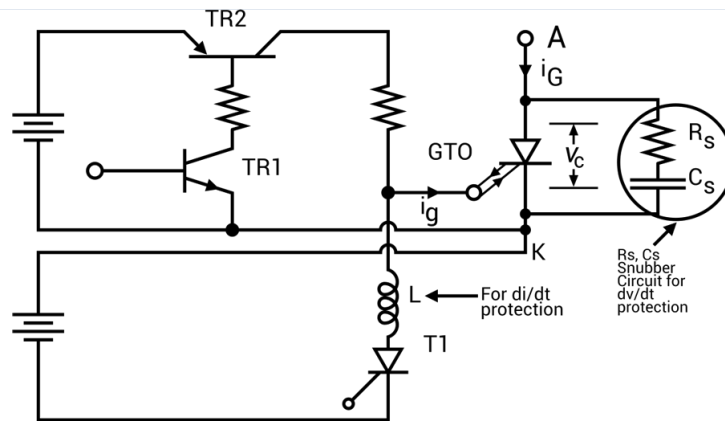


**Figure 42. Symbol of GTO**

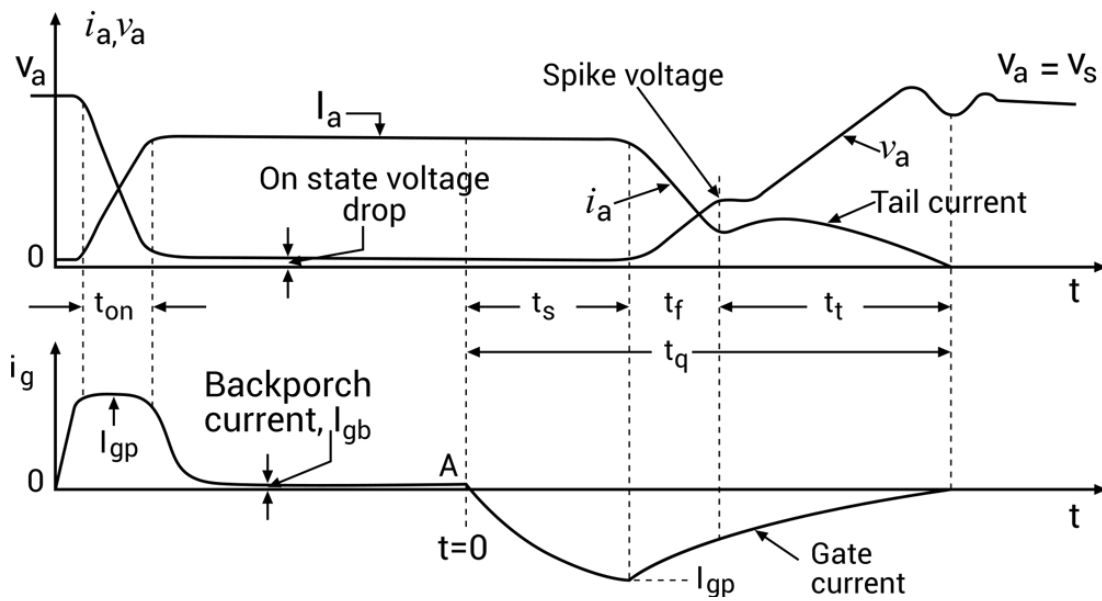
Overall switching speed of GTO is faster than thyristor (SCR) but voltage drop of GTO is larger. The power range of GTO is better than BJT, IGBT or SCR.

The static voltage current characteristics of GTO are similar to SCR except that the latching current of GTO is larger (about 2 A) as compared to SCR (around 100-500 mA).

The gate drive circuitry with switching characteristics is given in Fig. 43 and Fig. 44.



**Figure 43. Gate Drive Circuit for GTO**



**Figure 44. Turn-On and Turn-Off Characteristics of GTO**

### MCT (MOS-Controlled Thyristor)

IGBT is an improvement over a BJT using a MOSFET to switch on or switch off the anode current. Similarly, MCT is an improvement over a thyristor with a pair of MOSFETs to switch the current. There are several devices in the MCT's family but the p-channel is commonly discussed. Its schematic diagram and equivalent circuit is given in Fig. 45 and Fig. 46. Its symbol is given in Fig. 47.

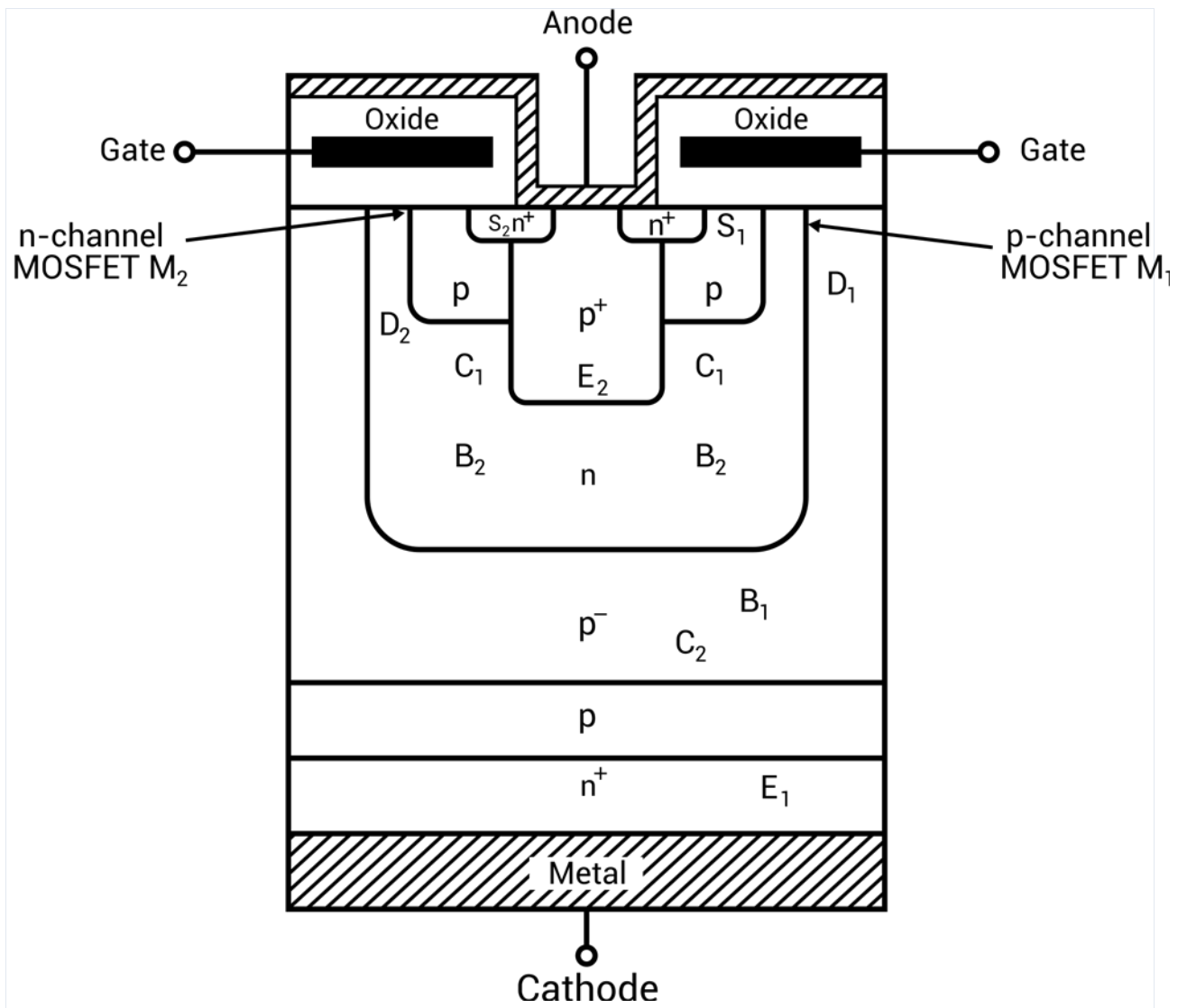
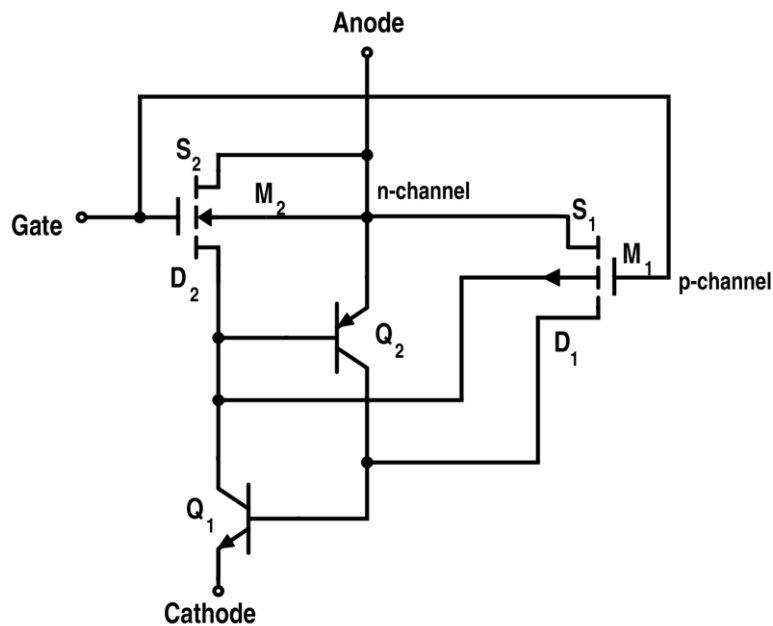
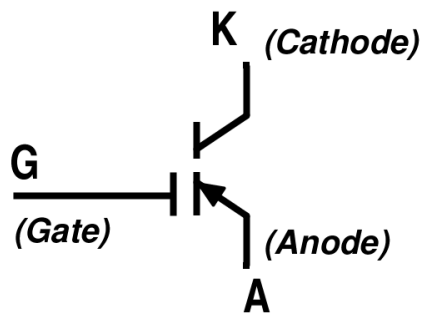


Figure 45. Schematic Diagram of P-Type MCT



**Figure 46. Equivalent Circuit for P-Type MCT**



**Figure 47. Symbol of P-Type MCT**

Due to NPNP structure instead of PNP, anode acts as a reference for gate. NPNP structure is represented by NPN transistor Q1 and a PNP transistor Q2 in the equivalent circuit.

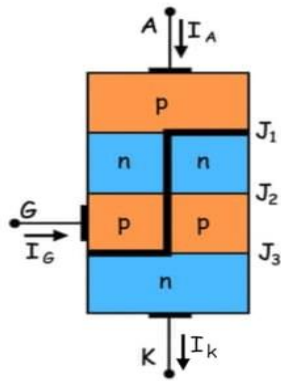
The power required to switch it on or off is small with low switching losses due to its distributed structure across the entire surface of the device. Delay time due to charge storage is also small. It also has a low on-state voltage drop.

When a p-type MCT is in the forward-blocking state, it can be switched on by applying a negative pulse to its gate (with respect to anode). While when an n-channel MCT is in the forward-blocking mode, it can be switched on with the positive gate pulse (with respect to cathode). It will remain on until the device current is reversed or a turn-off pulse is applied to the gate i.e. applying a positive gate pulse for p-type MCT with respect to anode.

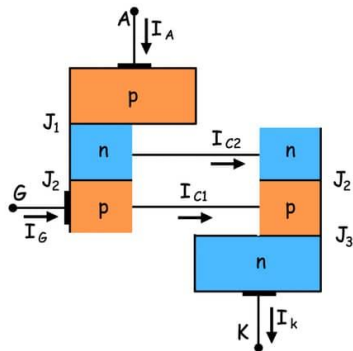
This device can bear a high current and high di/dt capability. But just like any other devices, it needs to be protected against transient voltages and current spikes with the help of suitable snubbers. It is used in capacitor discharge applications, circuit breakers, AC-AC or AC-DC conversion. It is an ideal replacement for GTO as it requires a much simpler gate drive and certainly more efficient.

## Two Transistor Model of SCR or Thyristor

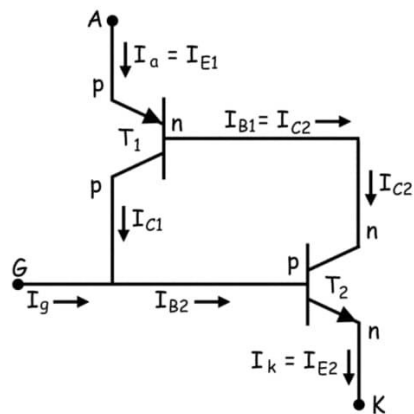
Basic operating principle of SCR, can easily be understood by the **two transistor model of SCR**, as it is a combination of p and n layers.



This is a pnpn thyristor. If we bisect it through the dotted line then we will get two transistors i.e. one pnp transistor with  $J_1$  and  $J_2$  junctions and another is with  $J_2$  and  $J_3$  junctions as shown in figure below.



The relation between the collector current and emitter current is shown below



Here,  $I_c$  is collector current,  $I_e$  is emitter current,  $I_{cB0}$  is forward leakage current,  $\alpha$  is common base forward current gain and relationship between  $I_c$  and  $I_b$  is

$$I_C = \beta I_B$$

Where,  $I_B$  is base current and  $\beta$  is common emitter forward current gain.

Let's for transistor  $T_1$  this relation holds

$$I_{C1} = \alpha_1 I_a + I_{CBO1} \dots (i)$$

And that for transistor  $T_2$

$$I_{C2} = \alpha_2 I_k + I_{CBO2} \dots (ii) \text{ again } I_{C2} = \beta_2 I_{B2}$$

Now, by the analysis of two transistors model we can get anode current,

$$I_a = I_{C1} + I_{C2} \text{ [applying KCL]}$$

From equation (i) and (ii), we get,

$$I_a = \alpha_1 I_a + I_{CBO1} + \alpha_2 I_k + I_{CBO2} \dots (iii)$$

If applied gate current is  $I_g$  then cathode current will be the summation of anode current and gate current i.e.

$$I_k = I_a + I_g$$

By substituting this value of  $I_k$  in (iii) we get,

$$I_a = \alpha_1 I_a + I_{CBO1} + \alpha_2 (I_a + I_g) + I_{CBO2}$$

$$I_a = \frac{\alpha_2 I_g + I_{CBO1} + I_{CBO2}}{1 - (\alpha_1 + \alpha_2)}$$

From this relation we can assure that with increasing the value of  $(\alpha_1 + \alpha_2)$  towards unity, corresponding anode current will increase. Now the question is how  $(\alpha_1 + \alpha_2)$  increasing? Here is the explanation using **two transistor model of SCR**.

At the first stage when we apply a gate current  $I_g$ , it acts as base current of  $T_2$  transistor i.e.  $I_{B2} = I_g$  and emitter current of the  $T_2$  transistor  $I_{E2} = I_k$ . Hence establishment of the emitter current gives rise  $\alpha_2$  as

$$\alpha_2 = \frac{I_{CBO1}}{I_g}$$

Presence of base current will generate collector current as

$$I_{C2} = \beta_2 \times I_{B2} = \beta_2 I_g$$

This  $I_{C2}$  is nothing but base current  $I_{B1}$  of transistor  $T_1$ , which will cause the flow of collector current,

$$I_{C2} = \beta_1 \times I_{B1} = \beta_1 \beta_2 I_g$$

$I_{C1}$  and  $I_{B1}$  lead to increase  $I_{C1}$  as  $I_a = I_{C1} + I_{B1}$  and hence,  $\alpha_1$  increases. Now, new base current of  $T_2$  is

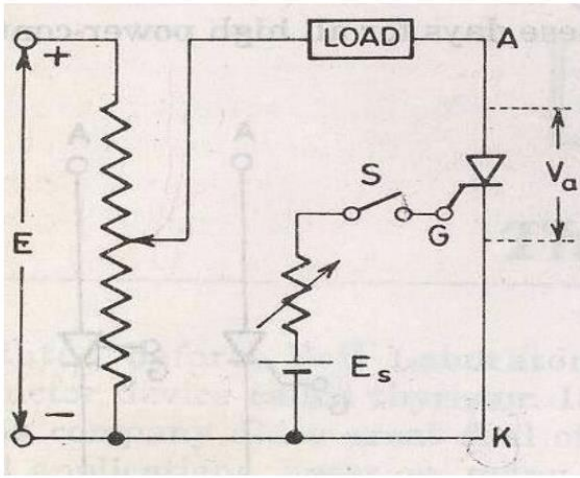
$$I_g + I_{C1} = (1 + \beta_1 \beta_2) I_g, \text{ which will lead to increase emitter current } I_k = I_a + I_{C1} \text{ and as a result } \alpha_2$$

also increases and this further increases  $I_{C2} = \beta_2 (1 + \beta_1 \beta_2) I_g$ .

As  $I_{B1} = I_{C2}$ ,  $\alpha_1$  again increases. This continuous positive feedback effect increases  $(\alpha_1 + \alpha_2)$  towards unity and anode current tends to flow at a very large value. The value of current then can only be controlled by external [resistance](#) of the circuit.

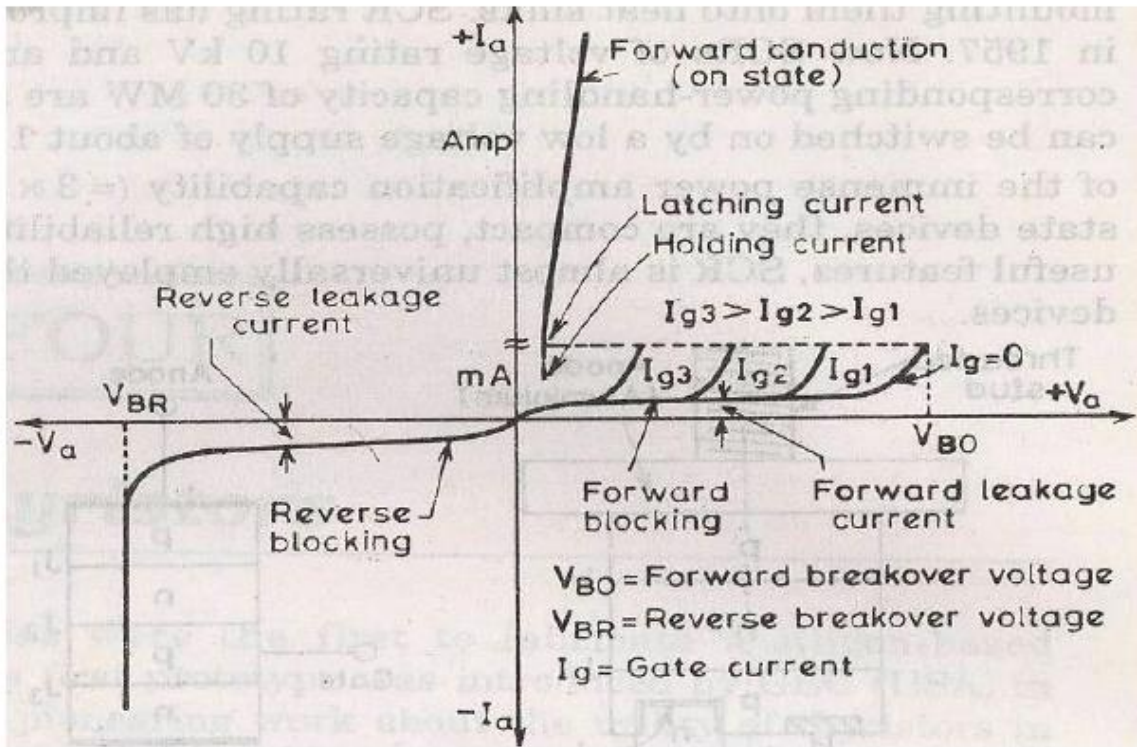
### Static V-I characteristics of a Thyristor

The circuit diagram for obtaining static V-I characteristics is as shown



Anode and cathode are connected to main source voltage through the load. The gate and cathode are fed from source  $E_s$ .

A typical SCR V-I characteristic is as shown below:



$V_{BO}$  = Forward breakover voltage

$V_{BR}$  = Reverse breakover voltage

$I_g$  = Gate current

$V_a$  = Anode voltage across the thyristor terminal A, K.

$I_a$  = Anode current

It can be inferred from the static V-I characteristic of SCR. SCR have 3 modes of operation:

1. Reverse blocking mode
2. Forward blocking mode ( off state)



### 3. Forward conduction mode (on state)

#### 1. Reverse Blocking Mode

When cathode of the thyristor is made positive with respect to anode with switch open thyristor is reverse biased. Junctions  $J1$  and  $J2$  are reverse biased where junction  $J2$  is forward biased. The device behaves as if two diodes are connected in series with reverse voltage applied across them.

A small leakage current of the order of few mA only flows. As the thyristor is reverse biased and in blocking mode. It is called as acting in reverse blocking mode of operation.

Now if the reverse voltage is increased, at a critical breakdown level called reverse breakdown voltage  $VBR$ , an avalanche occurs at  $J1$  and  $J3$  and the reverse

current increases rapidly. As a large current associated with  $V_{BR}$  and hence more losses to the SCR.

This results in Thyristor damage as junction temperature may exceed its maximum temperature rise.

## 2. Forward Blocking Mode

When anode is positive with respect to cathode, with gate circuit open, thyristor is said to be forward biased. Thus junction  $J_1$  and  $J_3$  are forward biased and  $J_2$  is reverse biased. As the forward voltage is increases junction  $J_2$  will have an avalanche breakdown at a voltage called forward breakover voltage  $V_{BO}$ . When forward voltage is less than  $V_{BO}$  thyristor offers high impedance. Thus a thyristor acts as an open switch in forward blocking mode.

## 3. Forward Conduction Mode

Here thyristor conducts current from anode to cathode with a very small voltage drop across it. So a thyristor can be brought from forward blocking mode to forward conducting mode:

1. By exceeding the forward breakover voltage.
2. By applying a gate pulse between gate and cathode.

During forward conduction mode of operation thyristor is in on state and behave like a close switch. Voltage drop is of the order of 1 to 2mV. This small voltage drop is due to ohmic drop across the four layers of the device.

## THYRISTOR OR SCR TRIGGERING

### SCR Triggering

Silicon controlled rectifier (SCR) or thyristor includes two stable states namely forward conduction and forward blocking. SCR triggering method can be defined as, when the SCR is switching in forward blocking state to forward conduction state which means OFF state to ON state, then it is termed as **SCR turn ON methods** or SCR triggering.

### SCR Triggering Methods

The SCR triggering mainly depends on different variables such as temperature, voltage supply, gate current, etc. When the voltage is applied to the silicon controlled [rectifier](#), if the anode terminal can be made +ve relating to the cathode, then the SCR turn into forwarding biased. Therefore this thyristor enters into the forward blocking state. This can be made to activate into conduction mode and it performs by using any type of the SCR Turn ON methods. There are different methods for activating the SCR which include the following.

- Forward Voltage Triggering
- Temperature Triggering
- $dv/dt$  Triggering
- Light Triggering
- Gate Triggering

### Forward Voltage Triggering

This kind of triggering method is mainly used to increase the voltage among the anode and cathode. So that the width of the depletion layer can be increased and makes to increase the accelerating voltage of minority charge carriers at  $J_2$  junction. Further, this can be lead to an [avalanche breakdown](#) of  $J_2$ - junction at a forward break over-voltage.

In this stage, silicon controlled rectifier can change into conduction mode & therefore a huge flow of current with a less drop of voltage will be there. Throughout the triggering state in the SCR, the range of forwarding voltage drop is 1 to 1.5 volts across the SCR. This may be amplified using the load current. In practical, this method cannot be used as it requires an extremely large anode voltage to the cathode. Once the voltage is high than the break over-voltage, then it offers extremely huge currents. This may cause harm to the thyristor. So, in most of the situations, this kind of SCR triggering method cannot be used.

## Temperature Triggering

This type of triggering mainly occurs because of some circumstances. It can increase sudden responses & then its results must be noted down while the element of any design method.

Temperature triggering of thyristors mainly occurs when the voltage across the J2 junction as well as leakage current can increase the junction's temperature. When the temperature increases then it will increase the leakage current.

This increasing method can be adequate to activate the thyristor, even though it tends to simply happen as the temperature of the device is high.

## dv/dt Triggering

In this type of triggering, whenever the SCR is in forwarding bias, then two junctions like J1 & J3 are in forwarding bias and J2 junction will be in reverse bias. Here, J2 junction performs like a capacitor because of the existing charge across the junction. If the 'V' is the voltage across the SCR, then the charge (Q) and capacitance can be written as

$$i_c = dQ/dt$$

$$Q = CV$$

$$i_c = d(CV) / dt = C \cdot dV/dt + V \cdot dC/dt$$

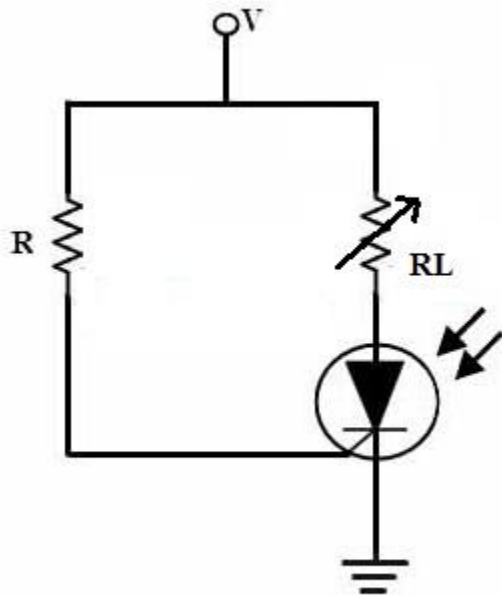
$$\text{When } dC/dt = 0$$

$$i_c = C \cdot dV/dt$$

Thus, as the change of voltage rate across the SCR turns into high or low, then the SCR may trigger.

## Light Triggering

When the SCR is triggered with the radiation of light is named as LASCR or Light Activated SCR. This kind of triggering is used for converters which are controlled by phase within HVDC systems. In this technique, intensity and light emissions with suitable wavelength are permitted to hit the J2 junction.



©Elprocus.com

These kinds of thyristors include a position within the P-layer. Thus, as the light strike on this position, the pairs of electron-hole can be produced at the J2 junction to give extra charge carriers at the leads of the junction to trigger the thyristor.

### Gate Triggering

Gate triggering is an efficient and most commonly used method to trigger the thyristor or SCR. As the thyristor is in forward biased, then an ample voltage on the gate terminal adds some electrons to the J2 junction. This affects to amplify reverse outflow current & therefore the J2 junction breakdown still at the voltage will be less than the VBO.

Based on the thyristor size, the gate current will change from a few mA to 200 mA. If the current which is applied to the gate terminal is high, then additional electrons will be inserted into the J2 junction & consequences to approach into the conduction position at less applied voltage.

In this technique, a positive voltage can be applied among the two terminals like the gate & the cathode. So, we can employ 3- kinds of gate signals for SCR triggering namely pulse signal, DC signal, and AC signal.

While designing the gate SCR triggering circuit, the following important points must be kept in your mind.

- When the SCR is triggered, then the gate signal must be detached instantly, otherwise, the power loss will be there within the gate junction.
- As an SCR is in reverse biased, then gate signal shouldn't be applied to this.
- The gate signal's pulse width must longer than the required time used for the anode current for increasing to the value of holding current.

## Switching Characteristics of SCR:

Switching characteristics of [SCR](#) is the time variation of voltage across its anode and cathode terminals and the current through it during its turn on and turn off process. This means, there will be two types of characteristics: One during turn on process and other during turn off process of SCR.

### *SCR or Thyristor Turn on Time*

Thyristor turn on time may be defined as the time required by the SCR to change its state from forward blocking mode to forward conduction mode when a gate pulse is applied. The total turn on time of SCR comprises of three different time intervals: Delay Time, Rise Time and Spread Time.

#### **Delay Time:**

The delay time is measured from the instant at which gate current reaches to  $0.9I_g$  to the instant at which anode current reaches  $0.1I_a$ . Here  $I_g$  and  $I_a$  are the final values of gate and anode current respectively.

There are various other ways to define delay time. It is also defined as the time during which anode voltage falls from  $V_a$  to  $0.9V_a$ . Here  $V_a$  is the initial value of anode to cathode voltage when SCR was in forward blocking mode.

Another way to define it is the time in which anode current reaches to  $0.1I_a$  from [forward leakage current](#).

The initiation of turn on process basically starts at gate to cathode junction. As soon as we apply gate current, charges are injected into the gate to cathode junction. This charge initially flows in a narrow path due to non-uniform charge distribution. Therefore the current density near the gate is more and decreases as the distance from gate junction increases. This means, during delay time the anode current flows in a narrow region near gate where gate current density is higher.

#### **Rise Time:**

Rise time is defined as the time taken by the anode current to rise from  $0.1I_a$  to  $0.9I_a$ . During this time, the anode to cathode voltage drops from  $0.9V_a$  to  $0.1V_a$ . Rise time is inversely proportional to the magnitude of gate current and its rate of rise. The more the value of gate current, the lesser will be the rise time.

During rise time, the current starts to spread from a narrow conducting region in the gate to cathode junction. But as the rise time is small, the anodes current do not get a change to spread over the entire cross section of cathode. Thus we can say that, like in delay time, the current during rise time also flows in a narrow region. However the area of this narrow region is more than that in case of delay time.

Since the current and voltage are more during rise time, the turn on losses in SCR is more during rise time.

#### **Spread Time:**

Spread time of SCR or thyristor is time taken by anode current to reach from  $0.9I_a$  to  $I_a$ . During this time period, the anode current spreads over the entire cross section of cathode. After the spread time, the anode current attains a steady state value and the voltage drop across the SCR terminals becomes equal to on stage voltage drop of the order of 1 to 1.5 V.

From the above discussion, we observe that an SCR is a charge controlled device during turn. This is also evident from the fact that, a certain amount of charge is injected by the gate current in the gate to cathode junction to bring the SCR in forward conduction mode from its forward blocking state. This means, the higher the value of gate current, the lesser will be the turn on time. In general, the magnitude of gate current to turn on SCR is about 3 to 5 times the minimum gate current required to trigger SCR. When the gate current is several times higher than the minimum gate current required, an SCR is said to be **hard fired or overdriven SCR**.

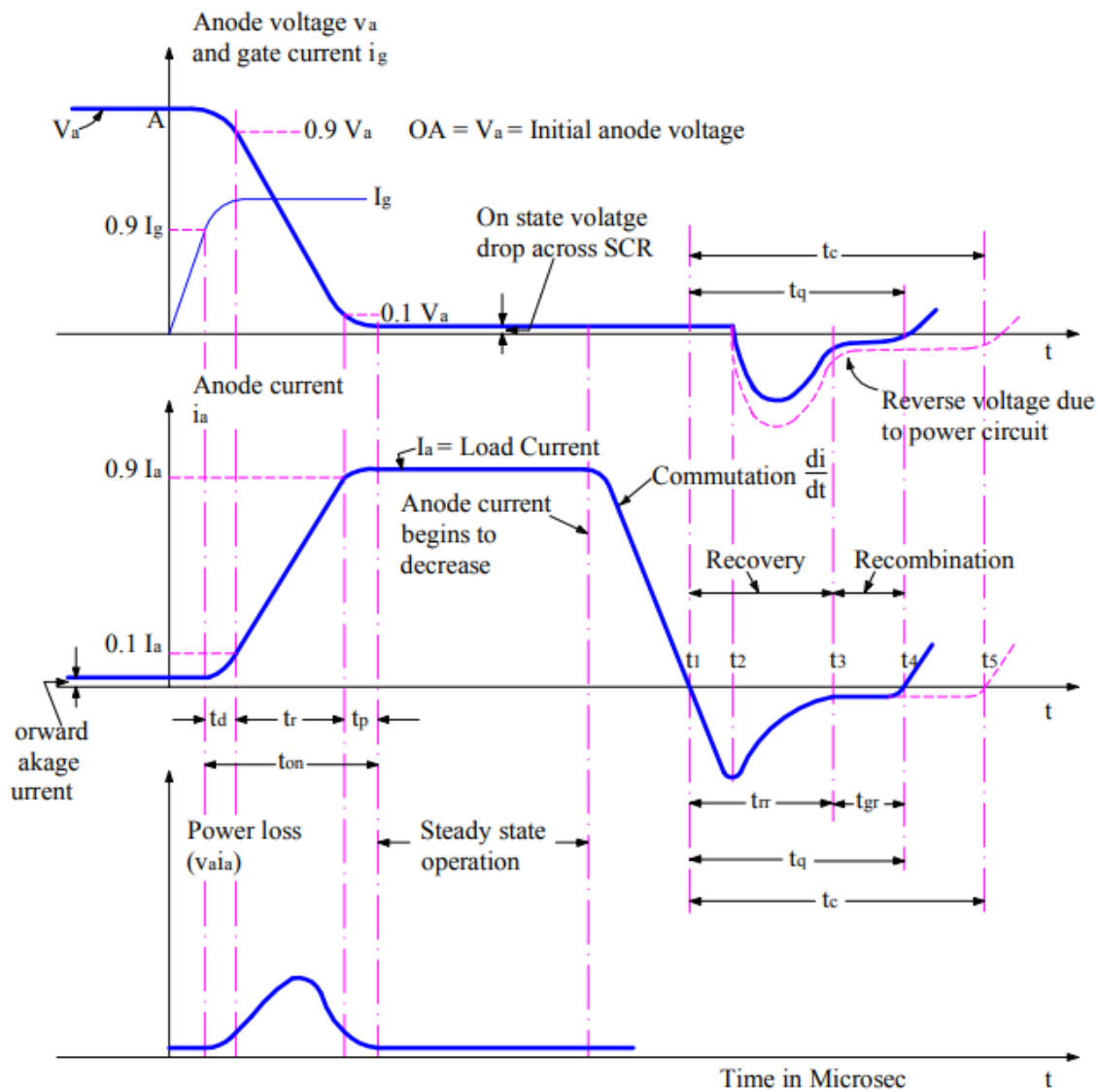
### Switching Characteristics of SCR during Turn Off

Switching Characteristics of SCR during Turn Off is the transition of SCR from [forward conduction state to forward blocking state](#). This transition process involves bringing the anode current below holding current, sweeping out of

charges from outer p and n junction and recombination of holes and electrons at the interior junction. Thus it is a dynamic process. This dynamic process of bringing SCR to off state is called **commutation process** or turn off process.

As we know that, once SCR is turned on, gate has no control over it. This means, the SCR will continue to be in conduction state even if gate current is removed. Ok, but now we want to turn off SCR. So what we need to do? We need to bring the anode current below holding current. But merely bringing anode current below holding current won't turn off SCR. This is because the charge carriers i.e. electrons and holes are still in favorable condition and if we apply forward voltage across anode and cathode terminals, SCR will begin to conduct. This means, we need to apply a reverse voltage for some finite time to give charge carriers time to be swept away from outer p and n junction due to reverse voltage. Once the charge has been swept away and recombined in inner junction where sweeping is not possible, the SCR will sustain forward voltage. At time stage, we will say that SCR is turned off. This whole process takes some time, which is known as turn off time of SCR.

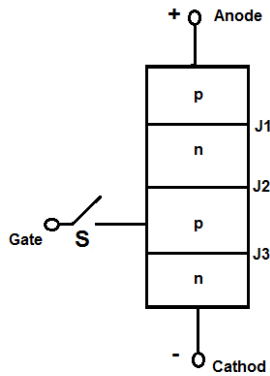
Turn off time ( $t_q$ ) is defined as the time in between the instant when anode current becomes zero to the instant when SCR regains forward blocking capability. During this time, all the excess carriers from outer p and n layers are removed as discussed above. This removal of excess carriers consists of sweeping out of holes from outer p-layer and electrons from outer n-layers. The carriers in the inner junction can only be swept away by recombination. Thus there are two different methods for sweeping out excess carriers. This lead to two different times. The time in which excess carriers are removed from two outer p and n layer is called **Reverse Recovery Time**  $t_{rr}$ . While the time in which carriers in inner layer is removed due to recombination is called the **Gate Recovery Time**,  $t_{gr}$



Following points can be noted with reference to above switching characteristics of SCR during turn off process:

- At instant  $t_1$ , the anode current becomes zero. But carriers are still under favorable condition, the anode current will start flowing in reverse direction with the same slope i.e.  $di/dt$ . This is actually good. This reverse current will help to sweep out excess holes from outer p-layer and excess holes from outer n-layer. This reverse current first increases but with the sweeping out of excess carriers, this current starts to decrease. At time  $t_2$ , when around 60 percent of carriers have been swept away from outer layers, the reverse anode current starts to decrease. The rate of decay of reverse current fast in the beginning but becomes gradual thereafter. This fast decay of reverse current cause a reverse voltage across the SCR or thyristor terminals and may therefore damage it. An RC element across SCR terminal helps to protect from such type of happening.
- At time  $t_3$ , when reverse current becomes almost zero, the excess carriers have been completely removed and now the SCR can withstand the reverse voltage.

- The reverse recovery time is, therefore,  $(t_3 - t_1)$ .



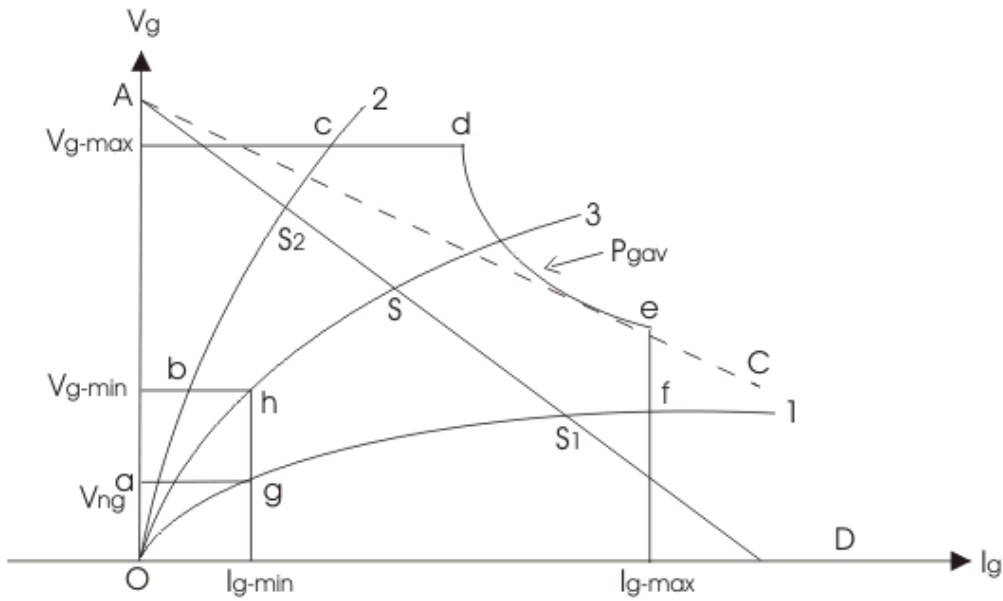
- After reverse recovery time  $t_{rr}$ , the excess carriers are still trapped in the inner junction J2. Therefore, the SCR is not able to block the forward voltage. Since the excess charge around junction J2 is not able to flow in the external circuit, therefore these trapped charges must decay due to recombination. This recombination is only possible if a reverse voltage is maintained across SCR for some finite time, though the magnitude of this reverse voltage is not important. This is because; the rate of recombination only depends on junction temperature. It is independent of external circuit parameter. The time for recombination of charge is called **Gate Recovery Time**,  $t_{gr}$ . Here the gate recovery time is  $(t_4 - t_3)$ .
- At instant  $t_4$ , as there is no excess charge, the SCR can withstand forward voltage. Hence we say that SCR has turned off. SCR or thyristor turn off time is in the range of 3-100  $\mu$ s.
- The SCR turn off time depends on the magnitude of anode current prior to starting of commutation process,  $di/dt$  and junction temperature. An increase in magnitude of these factors, increases the thyristor turn off time. However, turn off time decreases with increase in magnitude of reverse voltage. This is because; high reverse voltage quickly sweeps out holes from outer p-layer and electrons from outer n-layers. Thus turn off time of SCR is not a constant parameter of thyristor, rather it is depends on the external circuit parameter.
- SCR forms a part of external circuit. The turn off time provided to the SCR or thyristor by the practical circuit is called **Circuit Turn off Time**,  $t_c$ . It is defined as the time between the instant anode current becomes zero to the instant reverse voltage across SCR terminals becomes zero. Circuit turn off time  $t_c$  must be greater than thyristor turn off time  $t_q$  for reliable commutation.

Thyristors with slow turn off time (50-100  $\mu$ s) is called converter grade SCR and those with fast turn off time (3-50  $\mu$ s) is called inverter grade SCR. Converter grade SCRs are cheaper and used for Phase Controlled Rectifiers, AC Voltage Controllers etc. Inverter grade SCRs are costlier and used for Chopper, Inverter and forced commutated converters.

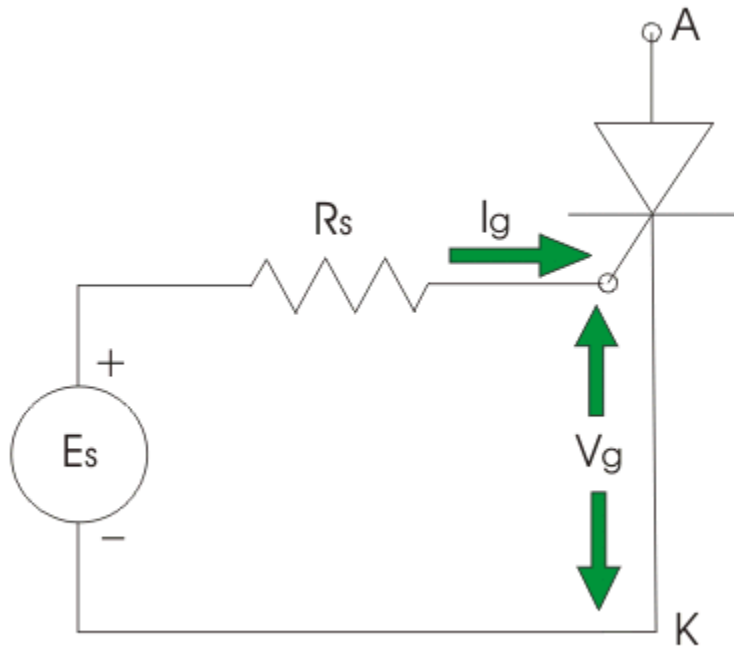
### Gate Characteristics of SCR

**Gate characteristic of thyristor or SCR** gives us a brief idea to operate it within a safe region of applied gate [voltage](#) and [current](#). So this is a very important characteristic regarding [thyristor](#). At the time of manufacturing each SCR or thyristor is specified with the maximum gate voltage limit ( $V_{g-max}$ ), gate current limit ( $I_{g-max}$ ) and maximum average gate power dissipation limit ( $P_{gav}$ ). These limits should not be exceeded to protect the SCR from damage and there is also a specified minimum voltage ( $V_{g-min}$ ) and minimum current ( $I_{g-min}$ ) for proper operation of a thyristor.





A gate non triggering voltage ( $V_{ng}$ ) is also mentioned at the time of manufacturing of the device. All noises and unwanted signals should lie under this voltage to avoid unwanted turn on of the thyristor.



Curve 1 represents the lowest voltage values that must be applied to turn on the SCR and curve 2 represents the highest values of the [voltage](#) that can safely applied. So from the figure we can see the safety operated area of SCR is bcdefghb.

Now, from the triggering circuit, we get,

$$E_s = V_g + I_g R_s$$

Where,

$E_s$  = gate source voltage

$V_g$  = gate cathode voltage

$I_g$  = gate current

$R_s$  = gate source resistance

A load line of gate source voltage is drawn as AD where  $OA = E_s$  and  $OD = E_s/R_s$  which is trigger circuit short circuit current. Now, let a VI characteristic of gate circuit is given by curve 3. The intersection point of load line (AD) and curve 3 is called as operating point S. It is evident that S must lie between  $S_1$  and  $S_2$  on the load line. For decreasing the turn ON time and to avoid unwanted turn ON of the device, operating point should be as close to  $P_{gav}$  as possible. Slope of AD = source resistance  $R_s$ . Minimum amount of  $R_s$  can be determined by drawing a tangent to the  $P_{gav}$  curve from the point A.

## COMMUTATION PROCESS

### SCR Turn OFF Methods:

The turn OFF process of an SCR is called **commutation**. The term commutation means the transfer of currents from one path to another. So the commutation circuit does this job by reducing the forward current to zero so as to turn OFF the SCR or Thyristor.

To turn OFF the conducting SCR the below conditions must be satisfied.

- The anode or forward current of SCR must be reduced to zero or below the level of holding current and then,
- A sufficient reverse voltage must be applied across the SCR to regain its forward blocking state.

It is of two types;

They are

- 1) Forced commutation
- 2) Natural commutation (Line commutation)

Forced commutation:

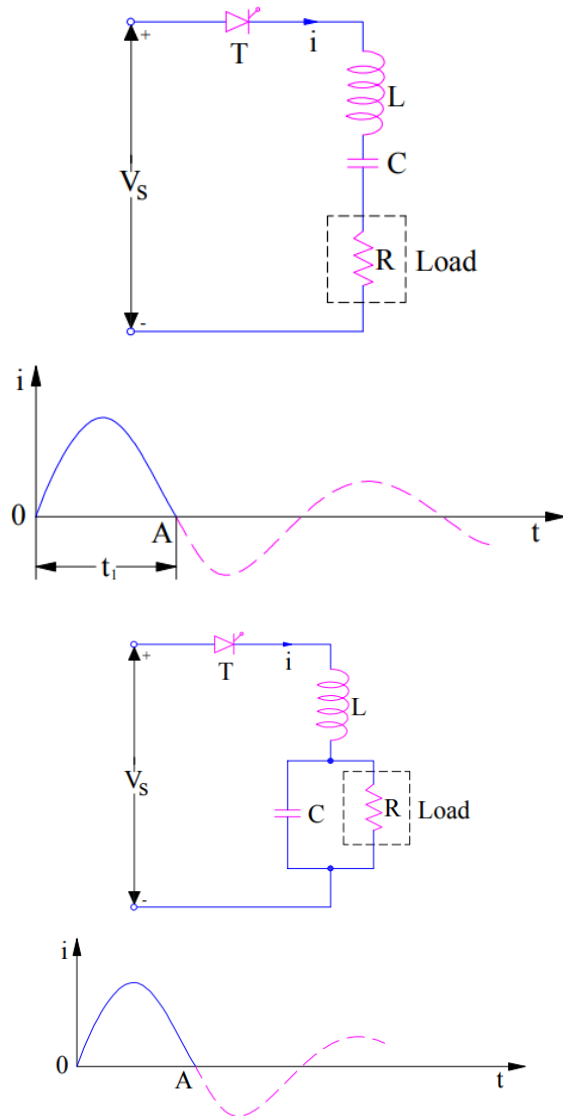
The commutation circuit is classified into different types;

- Class-A Commutation (Self or Load Commutation)
- Class-B Commutation (Resonant-Pulse Commutation)
- Class-C Commutation (Complementary Commutation)
- Class-D Commutation (Impulse Commutation)
- Class-E Commutation (External Pulse Commutation)

### Load Commutation of SCR – Class A Commutation :

Load commutation of SCR is a forced commutation technique in which SCR is forced to turn off. Turning off an SCR essentially requires its anode current to fall below holding current and a reversed biased voltage must be present across SCR for sufficient time so that SCR may regain its blocking state. Load Commutation of SCR is also known as Class-A commutation.

In Load Commutation, Capacitor C & Inductor L are used as commutating element. Commutating element L and C are connected in series with the load resistance if the value of load resistance is low. Circuit diagram for load commutation for low value of load resistance R is shown in figure below.



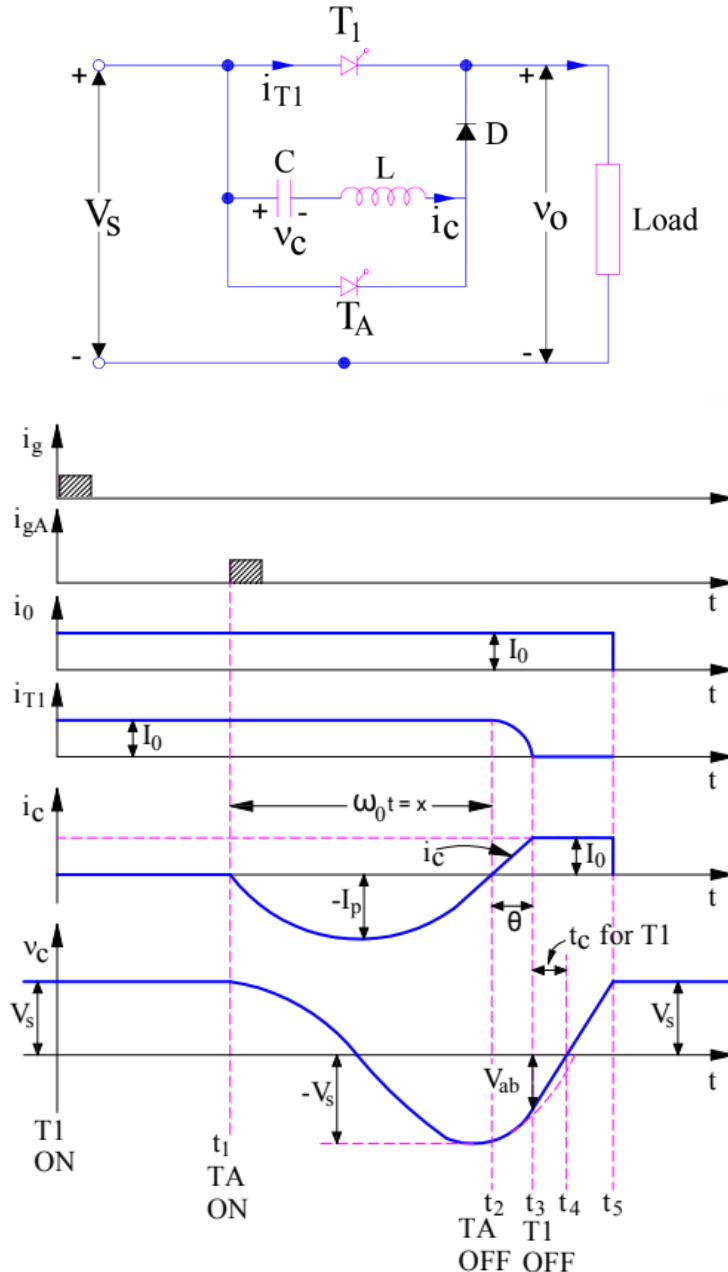
When the above circuit is energized from DC source, current waveform as shown in figure is obtained. As can be seen, the circuit current is under-damped in nature. The current is rising initially up to maximum and then begins to fall. When the current decays to zero (Capacitor is fully charges at instant A and hence will not allow further current flow) and tends to reverse. During the time when SCR conducts, voltage across SCR ( $V_T$ ) is zero. But as soon as current reaches zero and tend to reverse, a reverse voltage (since capacitor C is fully charged up to source voltage  $V_s$ , this capacitor voltage is applied across SCR) equal to the source voltage is applied across the terminals of SCR. Thus after time A, anode current of SCR is zero and it is reversed biased. The two conditions of SCR turn-off are met and hence SCR / thyristor is turned off on its own at instant A.

it is quite clear that the main idea behind load commutation technique is to make an under-damped circuit.

Class-A or Load commutation is prevalent in SCR circuit energized from a DC source like Series Inverter. The nature of the DC circuit should be such that when energized, the current should have a natural tendency to decay down to zero. Thus load commutation is only possible in DC circuit not in AC circuit.

Class-B or Resonant Pulse Commutation of SCR :

Class-B or Resonant Pulse Commutation is a **forced commutation** technique to turn off an **SCR**. In this technique, thyristor or SCR is turned off by gradual build-up of resonant current in the reverse direction i.e. from cathode to anode of SCR. This technique is also known as current commutation and occurs in DC circuit not in AC circuit.



Class B commutation is also called as Resonant-Pulse Commutation. There is only a small change between Class B and Class A circuit. In class B LC resonant circuit is connected in parallel while in Class A it's in series.

Now, as we apply the input voltage, the capacitor starts charging upto the input voltage ( $V_S$ ) and Thyristor remains reversed biased until the gate pulse is applied. When we apply the gate pulse, the Thyristor turns ON and now the current start flowing from both the ways. But, then the constant load current flows through the resistance and inductance connected in series, due to its large reactance.

Then a sinusoidal current flow through the LC resonant circuit to charge the capacitor with the reverse polarity. Hence, a reverse voltage appears across the Thyristor, which causes the current  $I_c$  (commutating current) to oppose the flow of the anode current  $I_A$ . Therefore, due to this opposing commutating current, when the anode current is getting lesser than the holding current, Thyristor turns OFF.

#### Line Commutation:

When an SCR circuit is energized from an AC source, current has to pass through its natural zero at the end of every half cycle. The AC source then applies a negative voltage across cathode and anode terminals of SCR.

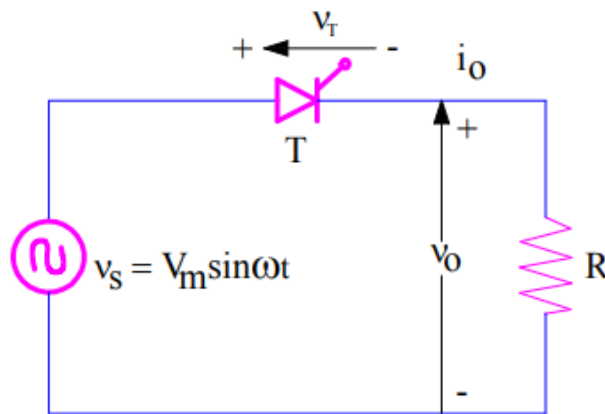
As we know that, the required conditions for SCR to turn off are

- Current through SCR must reach below its holding current, and
- SCR must be reversed biased for a time more than its turn off time ( $t_q$ ) so that it may recover the stored charges.

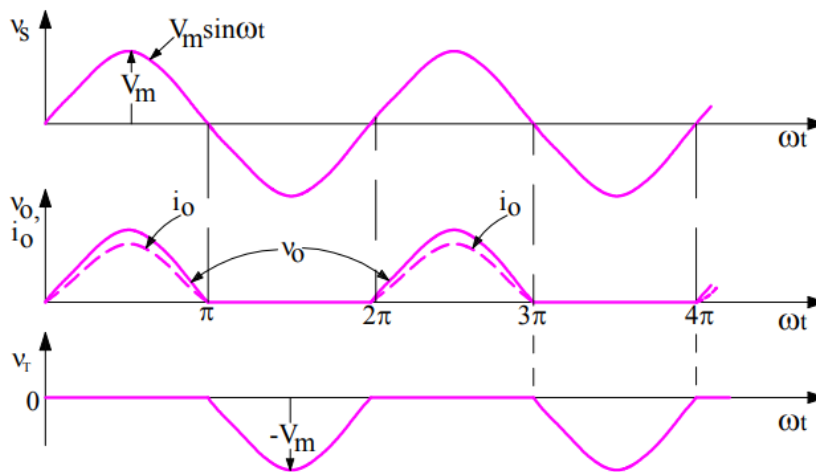
Since, current reaches zero at the end of every half cycle and voltage across the SCR is negative, hence SCR will turn off provided the half time period must be greater than SCR turn off time  $t_q$ .

#### Circuit Diagram of Natural or Line Commutation:

Let us consider a simple circuit as shown in figure below. The circuit is energized by an AC source.



Let us also assume that, thyristor T is fired or gated at firing angle equal to zero i.e.  $\omega t = 2n\pi$  where  $n$  is  $0, 1, 2, 3, \dots$ . Since load is resistive, with zero degree firing angle, the SCR behaves like a diode. During positive half cycle, the SCR will conduct as it is forward biased. The output voltage  $V_o = (V_s/R)$  will have same wave shape as that of source  $V_s$ . Load current  $i_o$  will be in phase with the load voltage  $v_o$ , hence  $i_o$  will have wave shape similar to load voltage  $v_o$  &  $v_s$ .



At  $\omega t = \pi$ , source voltage  $v_s = 0$ , load voltage  $v_o = 0$  and load current  $i_o = 0$ . Therefore, the current through the SCR becomes zero at this instant and it is reversed biased from  $\omega t = \pi$  to  $2\pi$ . Refer the voltage profile curve  $V_T$  across

thyristor in the above figure. This means, SCR is reversed biased for a time of  $t = (\pi/\omega)$ . If this time  $t$  is more than SCR turn off time  $t_q$ , the SCR will turn off or commutated. **Time  $t$  for which SCR is reversed biased is called circuit turn off time  $t_c$ .**

**Hence circuit turn off time for Natural or Line or Class-F commutation is  $t_c = (\pi/\omega)$ .**

Why it called Natural Commutation?

The commutation of SCR does not involve any external circuit. SCR is commutated just because of the natural reversal of AC load current and source voltage, this is the reason it is called Natural Commutation.

### SCR Protection

Protection of a device is an important aspect for its reliable and efficient operation. Silicon Controlled Rectifier (SCR) are a very delicate semiconductor device. So we have to use it in its specified ratings to get desired output. SCR may face different types of threats during its operation due to over voltages, over currents etc. There are different types of **thyristor protection** schemes available for satisfactory operation of the device like

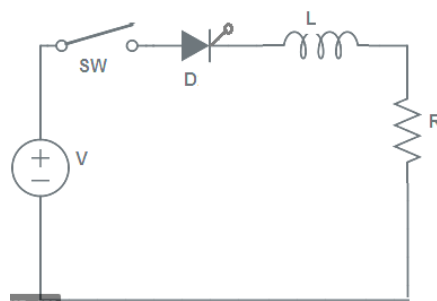
1. High  $dv/dt$  protection.
2. High  $di/dt$  protection.
3. Over voltage protection.
4. Over current protection.
5. Gate protection

### $di/dt$ Protection of SCR

The anode current starts flowing through the SCR when it is turned ON by the application of gate signal. This anode current takes some finite time to spread across the junctions of an SCR. For a good working of SCR, this current must spread uniformly over the surface of the junction.

If the rate of rise of anode current ( $di/dt$ ) is high results a non-uniform spreading of current over the junction. Due to the high current density, this further leads to form local hot spots near the gate-cathode junction. This effect may damage the SCR due to overheating. Hence, during turn ON process of SCR, the  $di/dt$  must be kept below the specified limits.

To prevent the high rate of change of current, an inductor is connected in series with thyristor. Typical SCR  $di/dt$  ratings are in range between 20- 500 ampere per microseconds.



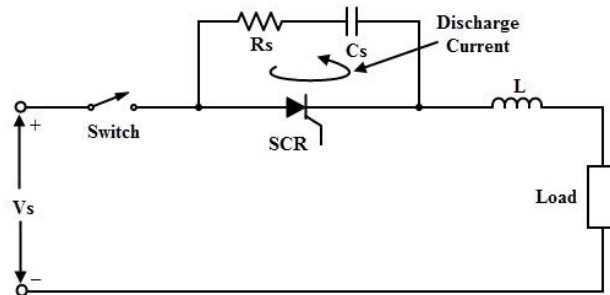
### $dv/dt$ Protection of SCR

When the SCR is forward biased, junctions  $J1$  and  $J3$  forward biased and junction  $J2$  is reverse biased. This reverse biased junction  $J2$  exhibits the characteristics of a capacitor. Therefore, if the rate of forward voltage applied is very high across the SCR, charging current flows through the junction  $J2$  is high enough to turn ON the SCR even without any gate signal.

This is called as  $dv/dt$  triggering of the SCR which is generally not employed as it is false triggering process. Hence, the rate of rise of anode to cathode voltage,  $dv/dt$  must be in specified limit to protect the SCR against false triggering. This can be achieved by using RC snubber network across the SCR.

### Working of Snubber Circuit

As we discussed above, the protection against high voltage reverse recovery transients and  $dv/dt$  is achieved by using an RC snubber circuit. This snubber circuit consists of a series combination of capacitor and resistor which is connected across the SCR. This also consist an inductance in series with the SCR to prevent the high  $di/dt$ . The resistance value is of few hundred ohms. The snubber network used for the protection of SCR is shown below.



When the switch closed, a sudden voltage appears across the SCR which is bypassed to the RC network. This is because the capacitor acts as a short circuit which reduces the voltage across the SCR to zero. As the time increases, voltage across the capacitor builds up at slow rate such that  $dv/dt$  across the capacitor is too small to turn ON the SCR. Therefore, the  $dv/dt$  across the SCR and the capacitor is less than the maximum  $dv/dt$  rating of the SCR.

Normally, the capacitor is charged to a voltage equal the maximum supply voltage which is the forward blocking voltage of the SCR. If the SCR is turned ON, the capacitor starts discharging which causes a high current to flow through the SCR.

This produces a high  $di/dt$  that leads to damage the SCR. And hence, to limit the high  $di/dt$  and peak discharge current, a small resistance is placed in series with the capacitor as shown in above. These snubber circuits can also be connected to any switching circuit to limit the high surge or transient voltages.

### Over Current Protection

Overcurrent mainly occurs due to different types of faults in the circuit. Due to overcurrent  $i^2R$  loss will increase and high generation of heat may take place that can exceed the permissible limit and burn the device.

Protective Measure: SCR can be protected from overcurrent by using Circuit Breaker (CB) and fast acting current limiting fuses (FACL). CBs are used for protection of thyristor against continuous overloads or against surge currents of long duration as a CB has long tripping time. But fast-acting fuses is used for protecting SCR against high surge current of very short duration.

### Overvoltage

Over voltages are the greatest causes of failure of SCRs. These transient over voltages often lead to unscheduled turn ON of the SCR. Also, may lead to the permanent destruction of the SCR if the reverse transient voltage is more than the VBR across the SCR.

There are several causes of appearing these over voltages like commutation , chopping , lightning , etc. Depends on these sources , over voltages are divided into two types internal and external over voltages.

### **Internal Overvoltages**

Internal over voltages arise while the SCR is in operation. During the turn OFF of an SCR, a reverse current continues to flow through the SCR after the anode current decreased to zero to sweep away the earlier stored charge. This reverse current decay at a faster rate at the end of reverse recover interval.

Due to the inductance of the circuit, this high  $di/dt$  produces a high voltage. This voltage value may be much higher than the rated value of the SCR and hence the SCR may be damaged.

### **External Overvoltages**

These voltages are arises from the supply source or load. Some of these are

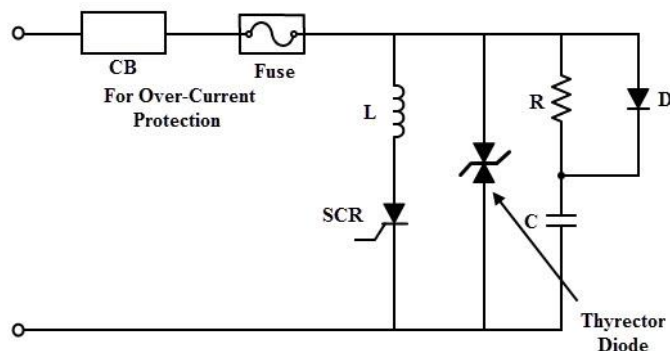
- If SCRs are in blocking mode in a converter circuit which is supplied with transformer, a small magnetizing current flow through the primary of the transformer. If the primary side switch is suddenly removed, a high voltage transient is produced in the secondary of the transformer and hence it is applied across the SCR. This voltage is several times that of the break over voltage of the SCR.
- Lightning surges on the HVDC systems to which SCR converters are connected causes a very high magnitude of over voltages.
- If the SCR converter circuit is connected to a high inductive load, the sudden interruption of current generates a high voltage across the SCRs.
- If the switches are provided on DC side, a sudden operation of these switches produces arc voltages. This also gives rise the over voltage across the SCR.

### **Protection Against Over voltages**

To protect the SCR against the transient over voltages, a parallel R-C snubber network is provided for each SCR in a converter circuit. This snubber network protects the SCR against internal over voltages that are caused during the reverse recovery process. After the SCR is turned OFF or commutated, the reverse recover current is diverted to the snubber circuit which consists of energy storing elements.

The lightning and switching surges at the input side may damage the converter or the transformer. And the effect of these voltages is minimised by using voltage clamping devices across the SCR. Therefore, voltage clamping devices like metal oxide varistors, selenium thyrector diodes and avalanche diode suppressors are most commonly employed.

These devices have falling resistance characteristics with an increase in voltage. Therefore, these devices provide a low resistance path across the SCR when a surge voltage appears across the device. The figure below shows the protection of SCR against over voltages using thyrector diode and snubber network.

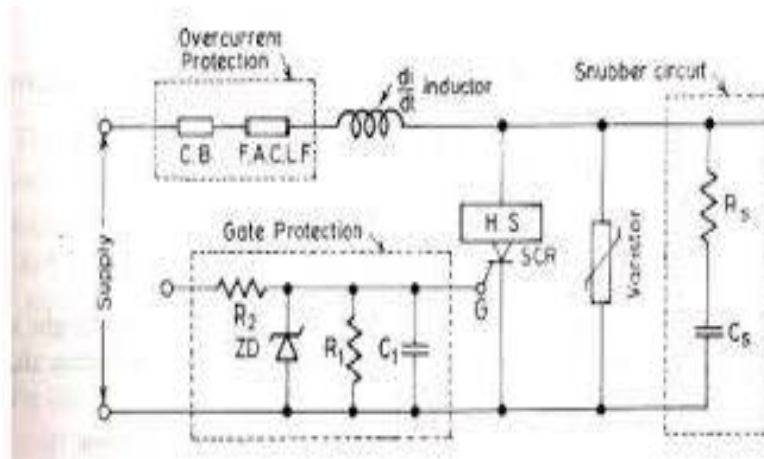




### Gate Protection:

Like a thyristor, Gate circuit should also be protected from overvoltages and overcurrents. Overvoltages in the gate circuit can cause false triggering and overcurrent can cause high junction temperature.

Protective Measure: Overvoltages **thyristor protection** is achieved by using a zener diode and a resistor can be used to protect the gate circuit from overcurrent. Noise in gate circuit can also cause false triggering which can be avoided by using a resistor and a capacitor in parallel. A diode (D) may be connected in series or in parallel with the gate to protect it from high reverse voltage.



### FIRING CIRCUIT OF SCR

#### Gate Triggering Methods

Types The different methods of gate triggering are the following

- R-triggering.
- RC triggering.
- UJT triggering.

**Resistance Triggering** A simple resistance triggering circuit is as shown. The resistor  $R_1$  limits the current through the gate of the SCR.  $R_2$  is the variable resistance added to the circuit to achieve control over the triggering angle of SCR. Resistor ' $R$ ' is a stabilizing resistor. The diode  $D$  is required to ensure that no negative voltage reaches the gate of the SCR.

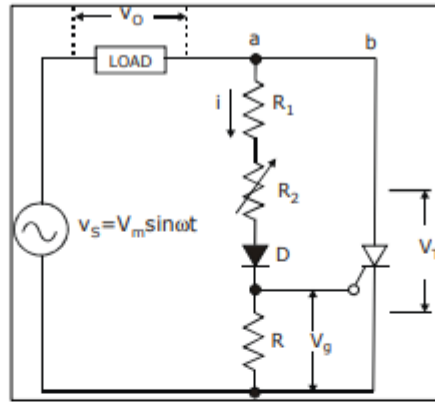
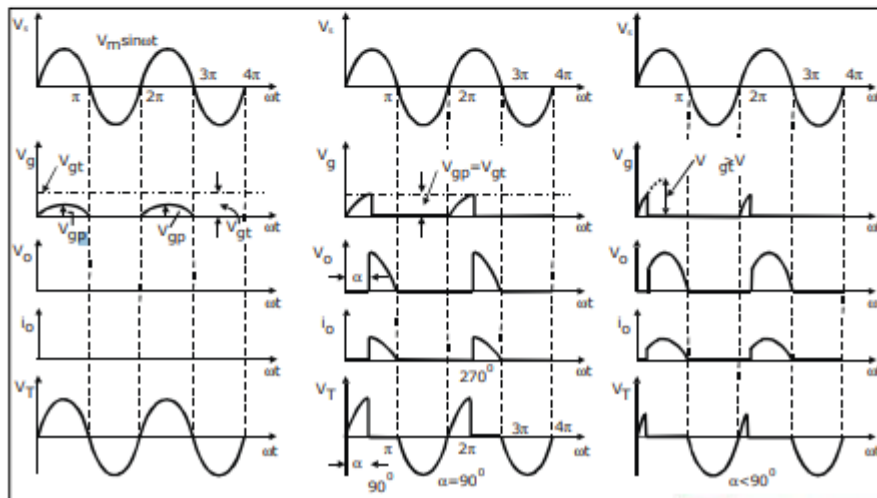


Fig.3.4: Resistance firing circuit



Resistance firing of an SCR in half wave circuit with dc load

(a) No triggering of SCR (b)  $\alpha = 90^\circ$  (c)  $\alpha < 90^\circ$

Design

With  $R_2 = 0$ , we need to ensure that  $V/R < I_{gm}$ , where  $I_{gm}$  is the maximum or peak gate current of the SCR. Therefore  $V/R \geq I_{gm}$ . Also with  $R_2 = 0$ , we need to ensure that the voltage drop across resistor 'R' does not exceed  $V_{gm}$ , the maximum gate voltage

$$V_{gm} \geq \frac{V_m R}{R_1 + R}$$

$$\therefore V_{gm} R_1 + V_{gm} R \geq V_m R$$

$$\therefore V_{gm} R_1 \geq R(V_m - V_{gm})$$

$$R \leq \frac{V_{gm} R_1}{V_m - V_{gm}}$$

Operation Case 1:  $V_{gp} < V_{gt}$ ,

the peak gate voltage is less than  $V_{gt}$  since  $R_2$  is very large. Therefore, current 'I' flowing through the gate is very small. SCR will not turn on and therefore the load voltage is zero and  $v_s$  is equal to  $V_s$ . This is because we are using only a resistive network. Therefore, output will be in phase with input.

Case 2:  $V_{gp} = V_{gt}$ ,  $R_2 \rightarrow$  optimum value.

When  $R_2$  is set to an optimum value such that  $V_{gp} = V_{gt}$ , we see that the SCR is triggered at  $90^\circ$  (since  $V_{gp}$  reaches its peak at  $90^\circ$  only). The waveforms show that the load voltage is zero till  $90^\circ$  and the voltage across the SCR is the same as input voltage till it is triggered at  $90^\circ$ .

Case 3:  $V_{gp} > V_{gt}$ ,  $R_2 \rightarrow$  small value.

The triggering value  $V_{gt}$  is reached much earlier than  $90^\circ$ . Hence the SCR turns on earlier than  $V_s$  reaches its peak value. The waveforms as shown with respect to  $V_s = V_m \sin \omega t$ .

$$\omega t = \alpha, V_s = V_{gt}, V_m = V_{gp} \left( \because V_{gt} = V_{gp} \sin \alpha \right)$$

Therefore 
$$\alpha = \sin^{-1} \left( \frac{V_{gt}}{V_{gp}} \right)$$

But 
$$V_{gp} = \frac{V_m R}{R_1 + R_2 + R}$$

Therefore 
$$\alpha = \sin^{-1} \left[ \frac{V_{gt} (R_1 + R_2 + R)}{V_m R} \right]$$

Since  $V_{gt}, R_1, R$  are constants

#### Resistance Capacitance Triggering

- A. RC Half Wave: Capacitor 'C' in the circuit is connected to shift the phase of the gate voltage. D1 is used to prevent negative voltage from reaching the gate cathode of SCR. In the negative half cycle, the capacitor charges to the peak negative voltage of the supply ( $-V_m$ ) through the diode D2. The capacitor maintains this voltage across it, till the supply voltage crosses zero. As the supply becomes positive, the capacitor charges through resistor 'R' from initial voltage of  $-V_m$ , to a positive value. When the capacitor voltage is equal to the gate trigger voltage of the SCR, the SCR is fired and the capacitor voltage is clamped to a small positive value.

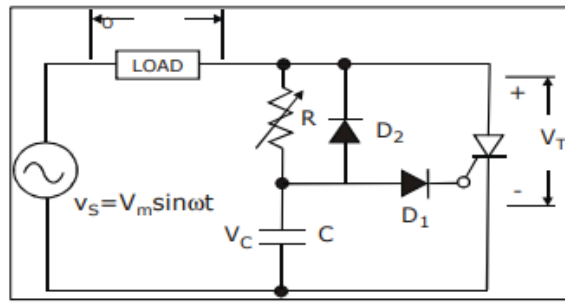
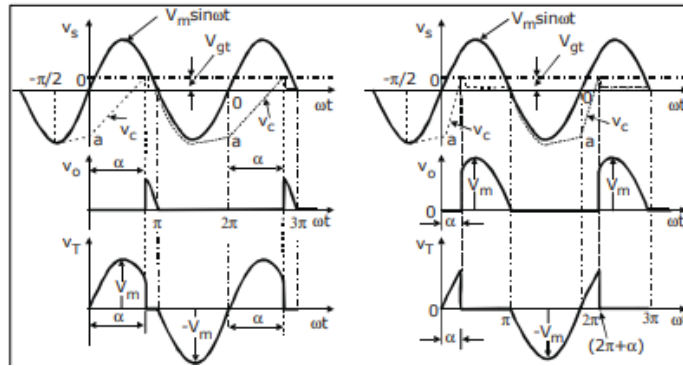


Fig.: RC half-wave trigger circuit



Waveforms for RC half-wave trigger circuit

(a) High value of R (b) Low value of R

Case 1:  $R \rightarrow$  Large. When the resistor 'R' is large, the time taken for the capacitance to charge from  $-V_m$  to  $V_{gt}$  is large, resulting in larger firing angle and lower load voltage.

Case 2:  $R \rightarrow$  Small When 'R' is set to a smaller value, the capacitor charges at a faster rate towards  $V_{gt}$  resulting in early triggering of SCR and hence  $V_L$  is more. When the SCR triggers, the voltage drop across it falls to  $1 - 1.5V$ . This in turn lowers, the voltage across R & C. Low voltage across the SCR during conduction period keeps the capacitor discharge during the positive half cycle.

Design Equation From the circuit  $V_C = V_{gt} + V_{d1}$ . Considering the source voltage and the gate circuit, we can write  $V_s = I_{gt} R + V_c$ . SCR fires when  $V_s \geq I_{gt} R + V_c$  that is  $V \geq I_{gt} R + V_{gt} + V_{d1}$ . Therefore  $R \leq \frac{V_s - V_{gt} - V_{d1}}{I_{gt}}$ . The RC time constant for zero output voltage that is maximum firing angle for power frequencies is empirically gives as  $RC \geq 1.3(T/2)$

RC Full Wave A simple circuit giving full wave output is shown in figure below. In this circuit the initial voltage from which the capacitor 'C' charges is essentially zero. The capacitor 'C' is reset to this voltage by the clamping action of the thyristor gate. For this reason the charging time constant RC must be chosen longer than for half wave RC circuit in order to delay the triggering. The RC value is empirically chosen as  $RC \geq 50T/2$  also  $R \leq \frac{V_s - V_{gt}}{I_{gt}}$ .

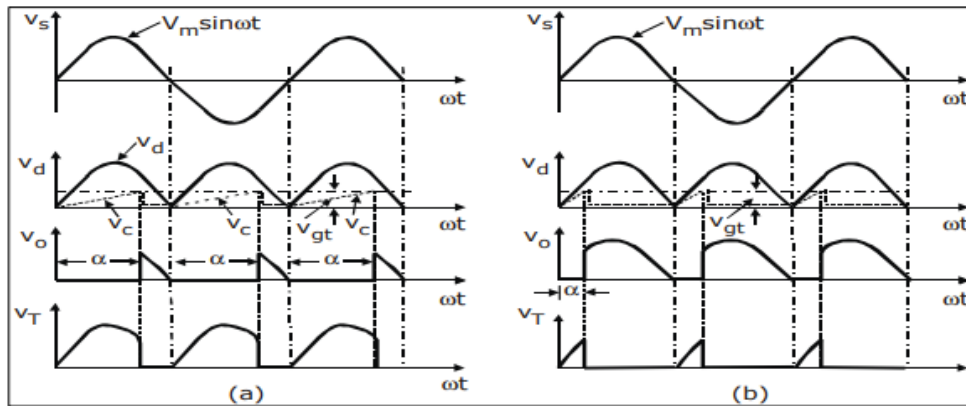
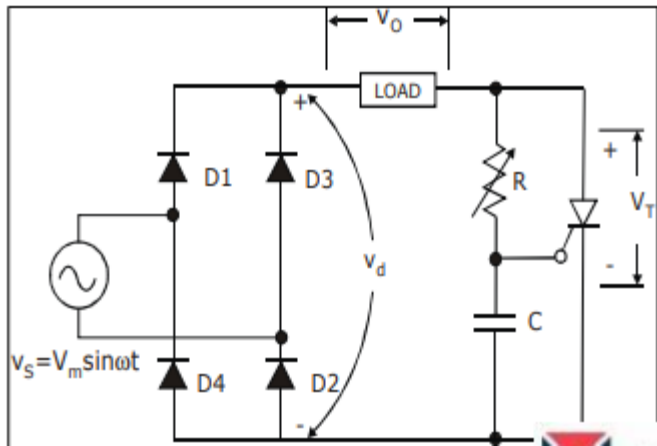
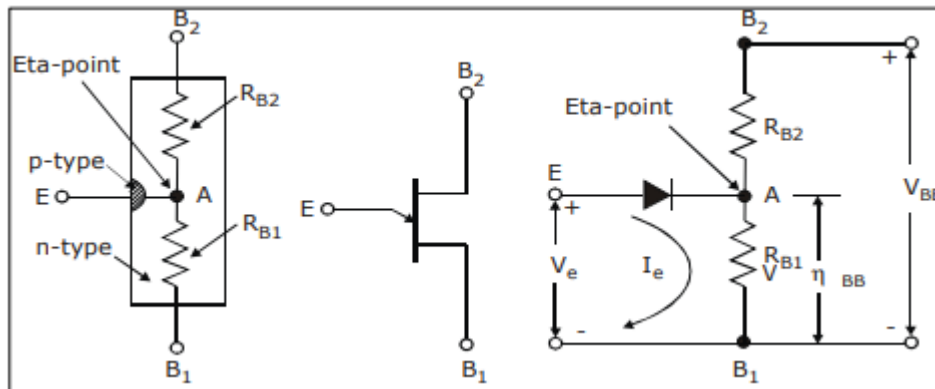


Fig 3.10: RC full-wave trigger circuit Fig: Wave-forms for RC full-wave trigger circuit

(a) High value of R

(b) Low value of R

UNI-JUNCTION TRANSISTOR (UJT):



UJT is an n-type silicon bar in which p-type emitter is embedded. It has three terminals base1, base2 and emitter 'E'. Between B1 and B2 UJT behaves like ordinary resistor and the internal resistances are given as  $R_{B1}$  and  $R_{B2}$  with emitter open  $R_{BB} = R_{B1} + R_{B2}$ . Usually the p-region is heavily doped and n-region is lightly doped. The equivalent circuit of UJT is as shown. When  $V_{BB}$  is applied across B1 and B2, we find that potential at A is

$$V_{AB1} = \frac{V_{BB} R_{B1}}{R_{B1} + R_{B2}} = \eta V_{BB} \left[ \eta = \frac{R_{B1}}{R_{B1} + R_{B2}} \right]$$

is intrinsic stand off ratio of UJT and ranges between 0.51 and 0.82. Resistor RB2 is between 5 to 10KΩ. Operation When voltage VBB is applied between emitter 'E' with base 1 B1 as reference and the emitter voltage VE is less than ((VD +η V BB) the UJT does not conduct. (VD +η V BB ) is designated as VP which is the value of voltage required to turn on the UJT. Once VE is equal to VP ≅VD+η VBE, then UJT is forward biased and it conducts. The peak point is the point at which peak current PI flows and the peak voltage VP is across the UJT. After peak point the current increases but voltage across device drops, this is due to the fact that emitter starts to inject holes into the lower doped n-region. Since p-region is heavily doped compared to n-region. Also holes have a longer life time, therefore number of carriers in the base region increases rapidly. Thus potential at 'A' falls but current EI increases rapidly. RB1 acts as a decreasing resistance.

negative resistance region of UJT is between peak point and valley point. After valley point, the device acts as a normal diode since the base region is saturated and RB1 does not decrease again.

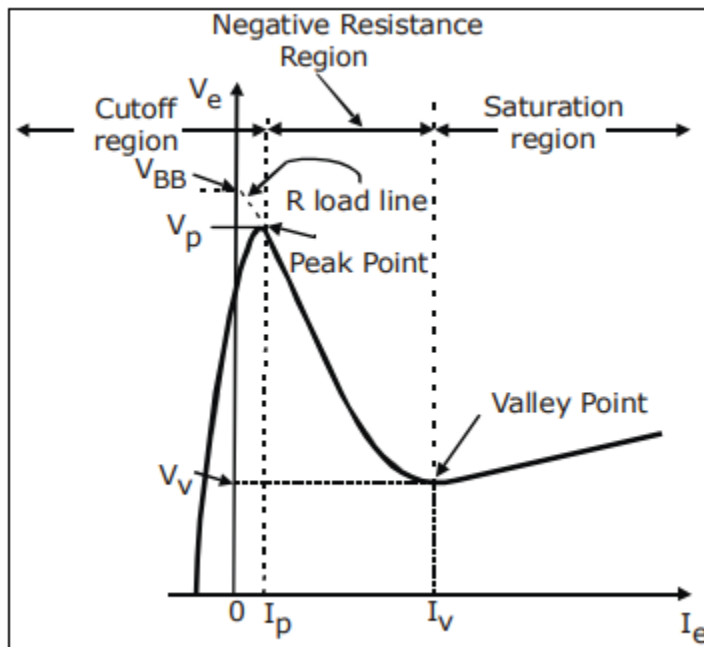


Fig.3.12: V-I Characteristics of UJT

## Chapter:2

# UNDERSTAND THE WORKING OF CONVERTERS AC REGULATORS AND CHOPPER

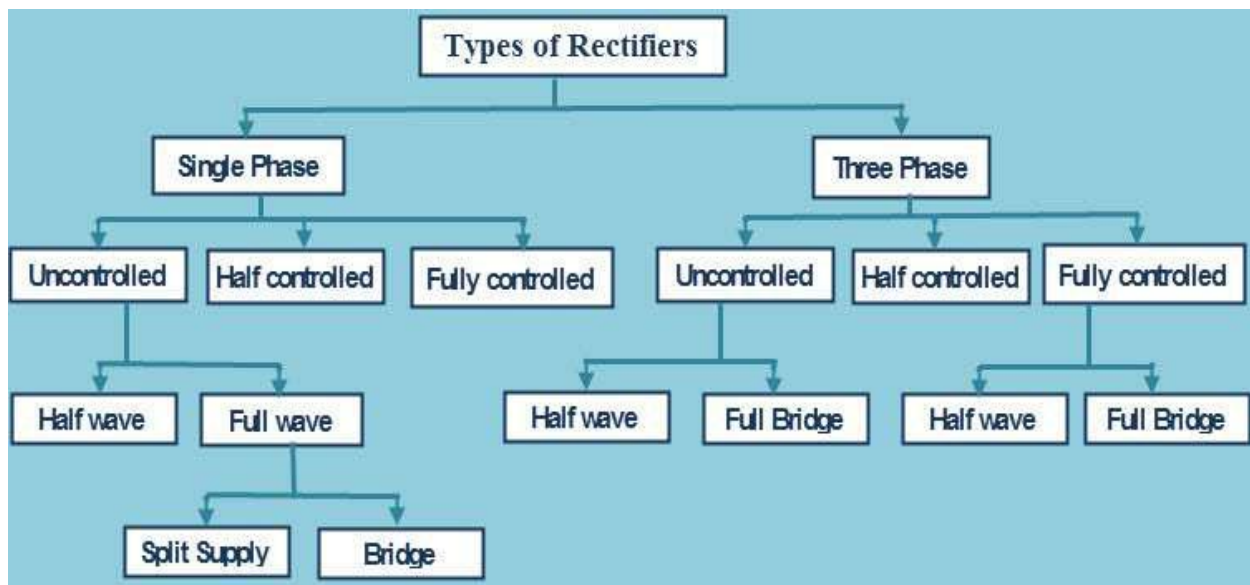
### INTRODUCTION :

Unlike diode rectifiers, phase controlled rectifiers has an advantage of controlling the output voltage. The diode rectifiers are called uncontrolled rectifiers. When these diodes are replaced with thyristors, then it becomes phase controlled rectifiers. The output voltage can be controlled by varying the firing angle of the thyristors. These phase controlled rectifiers have their main application in speed control of DC motors.

### APPLICATIONS

- Steel rolling mills, paper mills, textile mills where speed control of DC motors are necessary.
- Electric traction.
- High voltage DC transmission
- Electromagnet power supplies

The phase controlled rectifier is classified into two types based on the type of input power supply.



In this unit, the following categories of phase controlled rectifiers will be studied in detail.

1. Single Phase Half Wave Controlled Rectifier with R Load.
2. Single Phase Half Wave Controlled Rectifier with RL Load.
3. Single Phase Half Wave Controlled Rectifier with RL Load and Freewheeling Diode.
4. Single Phase Full Wave Controlled Rectifier with R Load.
5. Single Phase Full Wave Controlled Rectifier with RL Load.
6. Three Phase Half Wave Controlled Rectifier with R Load.
7. Three Phase Full Wave Controlled Rectifier with R Load.

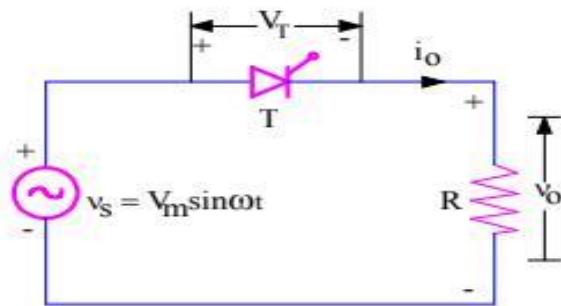
### Single Phase Half Wave Controlled Rectifier with pure resistive ( R ) Load

Figure Shows the circuit diagram of Single Phase Half Wave Controlled Rectifier with Resistive Load. In this Circuit, an SCR ( T ) is used to rectify the incoming Sine Wave from the Input, and this rectified output will be supplied to an Resistive load.

$V_0$  = Load output voltage

$i_0$  = Load current

$V_T$  = Voltage across the Thyristor

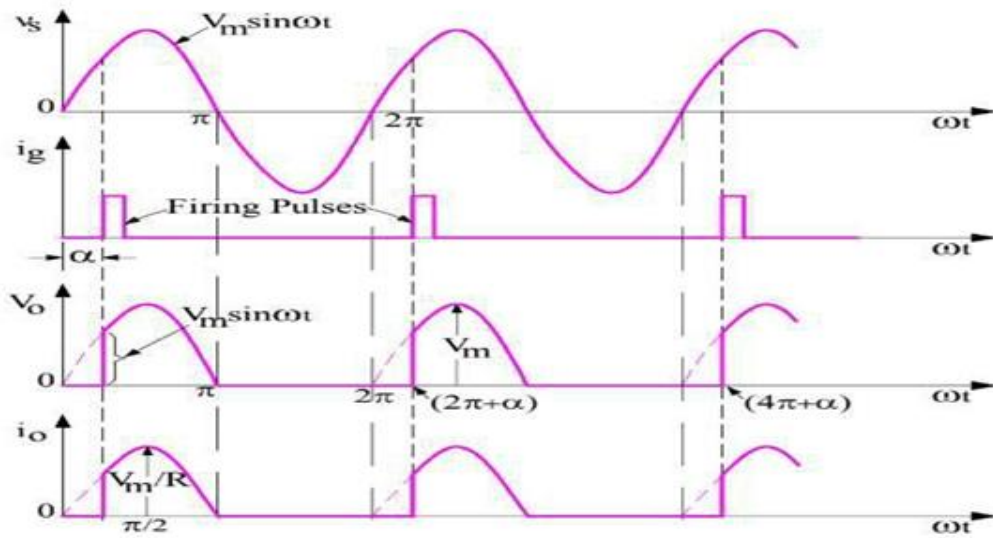


During the Positive Half Cycle of the Input Supply, the SCR ( T ) is forward biased. The load output voltage is zero till SCR triggered. During this cycle, the SCR is Triggered at a firing angle  $\omega t = \alpha$  and SCR ( T ) will Start conducting. But as soon as the supply voltage becomes zero at  $\omega t = \pi$ , the load current will become zero

After  $\omega t = \pi$  ( During Negative Half Cycle ), SCR ( T ) is reversed biased and will Turned OFF at  $\omega t = \pi$  and will remain in OFF condition till it is fired again at  $\omega t = (2\pi + \alpha)$ .

The wave shapes for voltage and current in case of Resistive load are shown below:





Therefore, the load output voltage and current for one complete cycle of input supply voltage may be written as

$$v_o = V_m \sin \omega t \quad \text{for} \quad \alpha \leq \omega t \leq \pi$$

$$i_o = V_m \sin \omega t / R \quad \text{for} \quad \alpha \leq \omega t \leq \pi$$

$$\begin{aligned} \therefore V_o(\text{Avg}) &= \frac{I}{2\pi} \int_0^{2\pi} V_m \sin(\omega t) d\omega t \\ &= \frac{V_m}{2\pi} [-\cos \omega t]_{\alpha}^{\pi} \\ &= \frac{V_m}{2\pi} (1 + \cos \alpha) \end{aligned}$$

**For Single Phase Half Wave Controlled Rectifier:**

***Average Value of Load output Voltage***

$$= \left( \frac{V_m}{2\pi} \right) [1 + \cos \alpha]$$

**RMS Value of Load output Voltage**

$$= \left( \frac{V_m}{2\sqrt{\pi}} \right) \sqrt{(\pi - \alpha) + (1/2)\sin 2\alpha}$$

$$I_{O(avg)} = \frac{I_m(1 + \cos \alpha)}{2\pi}$$

$$= \frac{V_m(1 + \cos \alpha)}{2\pi R}$$

The RMS value of the load current is given by

$$I_{RMS} = \left( \frac{I_m}{2} \right) \left[ 1 - \frac{\alpha}{\pi} + \frac{\sin 2\alpha}{2\pi} \right]^{\frac{1}{2}}$$

**Single Phase Half-Wave Controlled Rectifier with Inductive-Load**

Figure Shows 1 (a) the circuit diagram of Single Phase Half Wave Controlled Rectifier with Inductive Load. In this Circuit, an SCR ( T ) is used to rectify the incoming Sine Wave from the transformer secondary, and this rectified output will be supplied to an inductive load, such as a motor winding or relay coil.

The wave shapes for voltage and current in case of an inductive load are given in Fig.1.b. The load is assumed to be highly inductive.

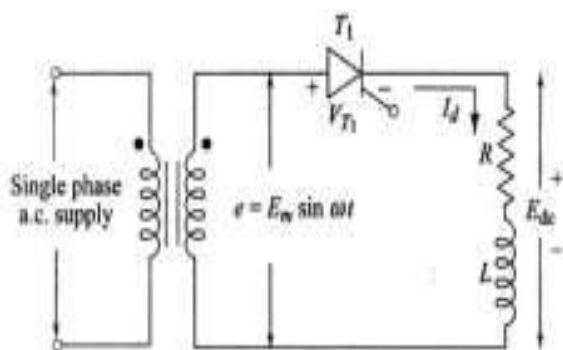
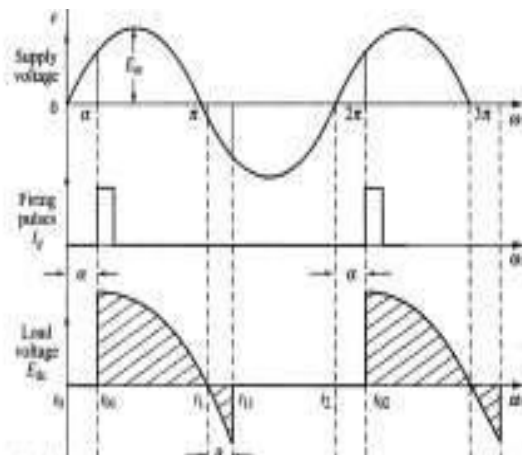


Fig.1(a) Half-wave controlled rectifier with R-L load



During the Positive Half Cycle of the Input Supply, the SCR ( T ) is forward biased. The load output voltage is zero till SCR triggered. During this cycle, the SCR is Triggered at a firing angle  $\omega t = \alpha$  and SCR ( T ) will Start conducting. The SCR will continue conducted in positive half cycle.

During Negative Half Cycle, when the supply voltage reverse, the SCR ( T ) is kept conducting continuously due to the fact that current through the inductance cannot be reduced to Zero. During negative voltage half-cycle, current will continuous flow till the energy stored in the inductance is dissipated in the load resistor and a part of the energy is fed back to the source.

The effect of inductive load is increased in the conduction period of SCR. Due to this reason, effective Load Voltage and Load Current will reduced. **This problem can be resolved by connecting a Free Wheeling Diode in anti- parallel with the inductive Load.**

$$\begin{aligned} \text{Avg. Voltage, } V_o &= \frac{1}{2\pi} \int_{\alpha}^{\beta} V_m \sin(\omega t) d(\omega t) \\ &= \frac{V_m}{2\pi} (\cos \alpha - \cos \beta) \end{aligned}$$

$$\text{Avg. Current, } I_o = \frac{V_m}{2\pi R} (\cos \alpha - \cos \beta)$$

$$\begin{aligned} \text{RMS Voltage, } V_o &= \sqrt{\frac{1}{2\pi} \int_{\alpha}^{\beta} (V_m \sin \omega t)^2 d(\omega t)} \\ &= \frac{V_m}{2\sqrt{\pi}} \sqrt{[(\beta - \alpha) - 1/2\{\sin 2\beta - \sin 2\alpha\}]} \end{aligned}$$

## Freewheeling Diode

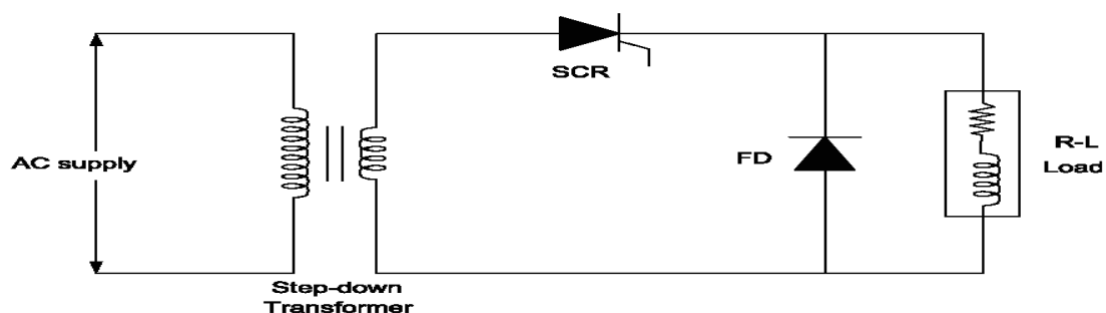
**Freewheeling Diode:-** A freewheeling diode is basically a diode connected across the inductive load terminals to prevent the development of high voltage across the switch. When the inductive circuit is switched off, this diode gives a short circuit path for the flow of inductor decay current and hence dissipation of stored energy in the inductor. This diode is also called Flywheel or Fly-back diode.

### Purpose of using Freewheeling Diode:

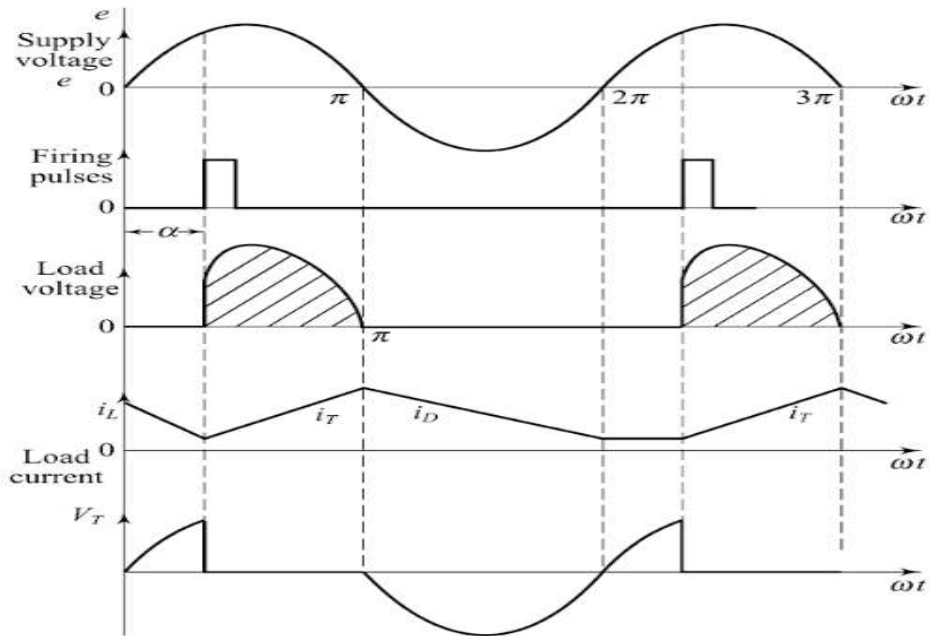
1. The Freewheeling Diode improves the waveform of the load current of Rectifier circuits, inverter circuits, and chopper circuits by making it continuous.
2. The Freewheeling protect the SCRs from damage in the circuits with Inductive Load from the excessive reverse voltage creating by the Inductive Load.
3. The Freewheeling Diode improves the Input Power Factor of Phase controlled Rectifiers.
4. The Freewheeling diode sustains the average output voltage of the circuit with Inductive Load.
5. It also helps to reduce Ripple components in the output signal of the circuit with Inductive Load.

### Single Phase Half-Wave Controlled Rectifier with Inductive-Load and Free Wheeling Diode

Figure Shows the circuit diagram of Single Phase Half Wave Controlled Rectifier with Inductive Load and Free Wheeling Diode. In this Circuit, an SCR is used to rectify the incoming sine wave from the transformer secondary, and this rectified output will be supplied to an inductive load, such as a motor winding or relay coil. The Free Wheeling Diode is connected across the Inductive Load in reverse biasing.



The wave shapes for voltage and current in case of an inductive load with Freewheeling Diode is shown below:



**Fig.3** Waveforms for half-wave controlled-rectifier with inductive load and freewheeling diode

During the Positive Half Cycle of the Input Supply, the SCR is forward biased. The load output voltage is zero till SCR triggered. During this cycle, the SCR is Triggered at a firing angle  $\omega t = \alpha$  and SCR will Start conducting. The SCR will continue conducted in positive half cycle and allowing the current through Inductive ( R-L ) Load. The freewheeling diode (FD) is reverse biased During this half-cycle.

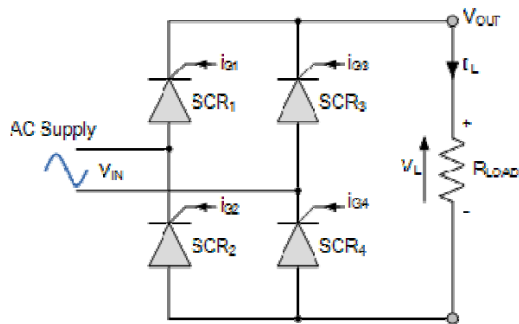
During the Negative Half-Cycle , the Freewheeling Diode becomes forward biased and the SCR will Turned OFF, the current that was previously flowing through the SCR and the load inductance, also starts to switch OFF, which causes the inductor to develop a large reverse voltage (positive on the bottom of the inductor, negative on the top) to try and maintain the previous current flow. This large reverse voltage spike would ordinarily be applied across the SCR (positive on the anode, negative on the cathode), potentially forcing it to continue to conduct when the gate is no longer enabled, and potentially damaging the SCR.

For this reason, a freewheeling diode (FD) is connected in parallel with the inductive load. With FD present, the large reverse voltage that would normally develop across the load inductance, causes FD to become forward biased, which acts like a short-circuit to clamp the reverse voltage spike that would otherwise occur to a safe level, corresponding to the forward voltage drop across FD and output voltage across the load will Zero during this Negative Half Cycle and current will flow continuously as shown in voltage & Current Wave shapes.

### **Single Phase Full Wave Fully-controlled Bridge Rectifier with Resistive Load:**

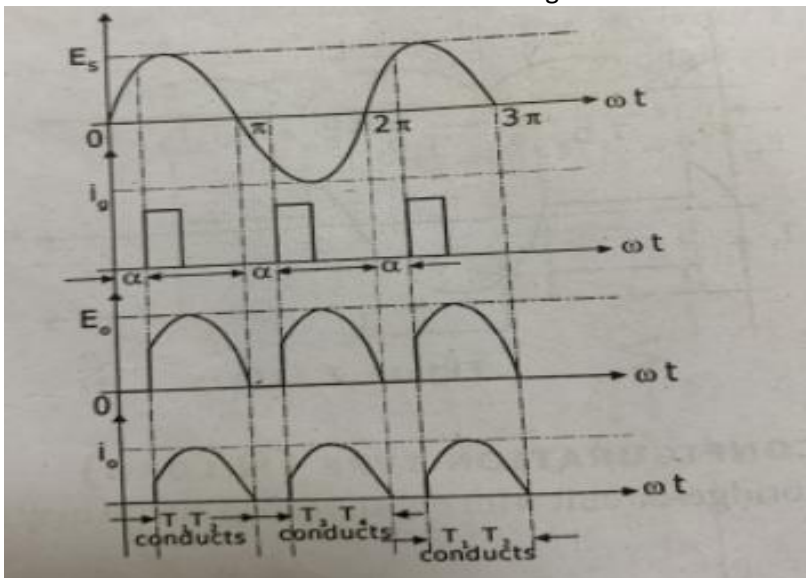
A Full Wave Full controlled rectifier is a device which converts AC supply into Controlled DC supply & This Fully controlled DC power supply fed to the load. This process of converting alternating current (AC) into direct current (DC) is also called as controlled rectification.

The Circuit Diagram Full Wave Full controlled rectifier is as shown below:



- In the Full Wave fully-controlled rectifier configuration, the average DC load voltage is controlled using two thyristors / SCRs per half-cycle.
- Thyristors SCR1 and SCR4 are fired together as a pair during the positive half-cycle, While thyristors SCR3 and SCR2 are also fired together as a pair during the negative half-cycle ( i.e. 180o after SCR1 and SCR4 ).
- During the Positive Half Cycle of the Input  $V_{IN}$  Signal , The Current flowing through the path of: Upper Terminal of the Supply ( + ) , SCR1 , Load (  $R_L$  ) , SCR4, and back to Lower Terminal ( - ) of the Supply .
- Similarly, During the Negative Half Cycle of Input  $V_{IN}$ , The Current flowing through the path of : Lower Terminal ( + ) , SCR3 , Load (  $R_L$  ) , SCR2 and back to Upper Terminal ( - ) of the Supply.
- As with the half-controlled rectifier, the output voltage can be fully controlled by varying the SCRs firing / delay angle ( $\alpha$ ).

Thus the expression for the average DC voltage from a single Full Wave phase fullycontrolled rectifier in its continuous conduction mode is given as:



The average value of the output DC voltage is given by:

$$V_{o(avg)} = \frac{1}{2\pi} 2 \int_{\alpha}^{\pi} \sqrt{2}V \sin(\omega t) d\omega t = \frac{1}{2\pi} 2 \int_{\alpha}^{\pi} V_m \sin(\omega t) d\omega t$$

$$V_{o(avg)} = \frac{V_m}{\pi} (1 + \cos \alpha)$$

$$I_{o(avg)} = \frac{V_{o(avg)}}{R} = \frac{V_m}{\pi R} (1 + \cos \alpha)$$

The rms values for the output voltage and current are given by:

$$V_{o(rms)} = \sqrt{\frac{1}{2\pi} 2 \int_{\alpha}^{\pi} (\sqrt{2}V \sin(\omega t))^2 d\omega t} = \sqrt{\frac{1}{2\pi} 2 \int_{\alpha}^{\pi} (V_m \sin(\omega t))^2 d\omega t}$$

$$V_{o(rms)} = \frac{V_m}{\sqrt{2}} \sqrt{\left(1 - \frac{\alpha}{\pi} + \frac{\sin 2\alpha}{2\pi}\right)}$$

$$I_{o(rms)} = \frac{I_m}{\sqrt{2}} \sqrt{\left(1 - \frac{\alpha}{\pi} + \frac{\sin 2\alpha}{2\pi}\right)}$$

The average and the rms values for SCR are given by:

$$I_{thav} = \frac{1}{2\pi} \int_{\alpha}^{\pi} \frac{\sqrt{2}V}{R} \sin(\omega t) d\omega t = \frac{1}{2\pi} \int_{\alpha}^{\pi} \frac{V_m}{R} \sin(\omega t) d\omega t = \frac{I_{o(avg)}}{2}$$

$$I_{th(rms)} = \sqrt{\frac{1}{2\pi} 2 \int_{\alpha}^{\pi} \left(\frac{\sqrt{2}V}{R} \sin(\omega t)\right)^2 d\omega t} = \sqrt{\frac{1}{2\pi} \int_{\alpha}^{\pi} \left(\frac{V_m}{R} \sin(\omega t)\right)^2 d\omega t} = \frac{I_{o(rms)}}{\sqrt{2}}$$

The output power is given by:

$$P_o = I_{o(rms)}^2 R = \frac{V_{o(rms)}^2}{R}$$

The input (supply) power factor is given by:

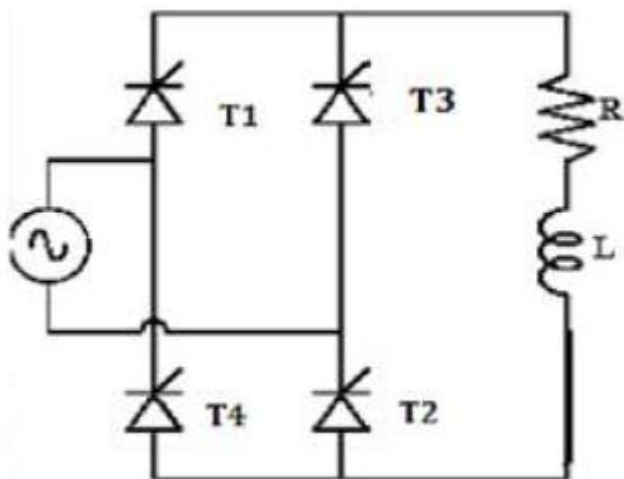
$$PF = \frac{I_{o(rms)}^2 R}{V_s I_{o(rms)}} = \frac{I_{o(rms)} R}{V_s}$$



## Full Wave Fully-controlled Bridge Rectifier With R-L Load :

In the Full Wave Fully-Controlled Rectifier Configuration, the average DC load voltage is controlled using two thyristors / SCRs per half-cycle. Thyristors T1 and T2 are fired together as a pair during the positive half-cycle, While thyristors T3 and T4 are also fired together as a pair during the negative half-cycle ( i.e. 180o after T1 and T2 ).

When the load is Inductive, the Output Voltage can be Negative for part of the cycle. This is because an inductor stores energy in its magnetic field which is later released. The Circuit Diagram Full Wave Full controlled rectifier with R-L Load is as shown below



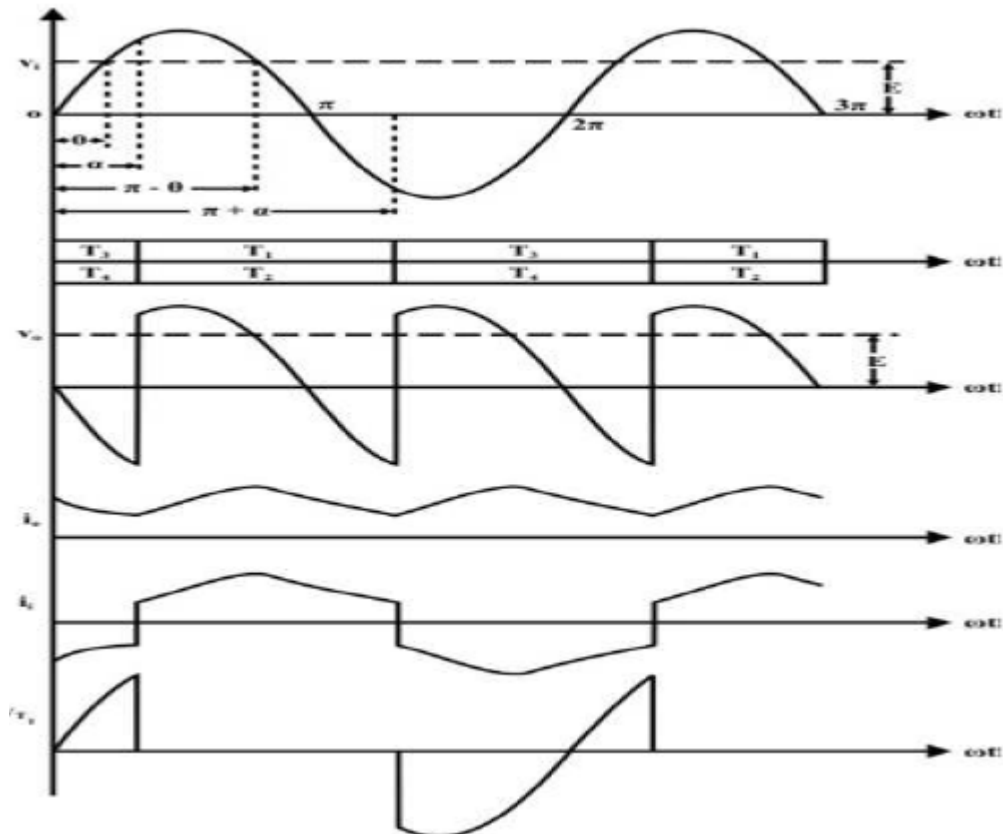
**Operation of this mode can be divided between four modes**

### **Mode 1 ( $\alpha$ to $\pi$ )**

In positive half cycle of applied ac signal, SCR's T1 & T2 are forward biased & can be turned on at an angle  $\alpha$ . Load voltage is equal to positive instantaneous AC supply voltage. The load current is positive, ripple free, constant and equal to  $I_o$ . Due to positive polarity of load voltage & load current, load inductance will store energy.

### **Mode 2 ( $\pi$ to $\pi + \alpha$ )**

At  $\omega t = \pi$ , input supply is equal to zero & after  $\pi$  it becomes negative. But inductance opposes any change through it. In order to maintain a constant load current & also in same direction. A self induced emf appears across 'L' as shown. Due to this induced voltage, SCR's T1 & T2 are forward biased in spite the negative supply voltage. The load voltage is negative & equal to instantaneous ac supply voltage whereas load current is positive. Thus, load acts as source & stored energy in inductance is returned back to the ac supply.



### Mode 3 ( $\pi + \alpha$ to $2\pi$ )

At  $\omega t = \pi + \alpha$ , SCR's T3 & T4 are turned on & T1, T2 are reversed bias. Thus, process of conduction is transferred from T1, T2 to T3, T4. Load voltage again becomes positive & energy is stored in inductor. T3, T4 conduct in negative half cycle from  $(\pi + \alpha)$  to  $2\pi$ . With positive load voltage & load current energy gets stored.

### Mode 4 ( $2\pi$ to $2\pi + \alpha$ )

At  $\omega t = 2\pi$ , input voltage passes through zero. Inductive load will try to oppose any change in current if in order to maintain load current constant & in the same direction. Induced e. m. f. is Positive & maintains conducting SCR's T3 & T4 with reverse polarity also. Thus VL is negative & equal to instantaneous AC supply voltage. Whereas load current continues to be positive. Thus load acts as source & stored energy in inductance is returned back to ac supply. At  $\omega t = \alpha$  or  $2\pi + \alpha$ , T3 & T4 are commutated and T1, T2 are turned ON.

The average value of this output voltage varies with  $\alpha$ :

$$V_o = \frac{1}{\pi} \int_{\alpha}^{\pi+\alpha} V_m \sin(\omega t) d(\omega t) = \frac{2V_m}{\pi} \cos \alpha$$

The average value of output current is given by:

$$I_{o(av)} = \frac{V_{o(av)}}{R} = \frac{2V_m \cos(\alpha)}{\pi R}$$

The average and rms values of the thyristor current are given by:

$$I_{th(av)} = \int_{\alpha}^{\pi+\alpha} I_{o(av)} d\omega t = \frac{I_{o(av)}}{2}$$

$$I_{th(rms)} = \sqrt{\int_{\alpha}^{\pi+\alpha} (I_{o(av)})^2 d\omega t} = \frac{I_{o(av)}}{\sqrt{2}}$$

The rms value of the supply current is given by:

$$I_{s(rms)} = \sqrt{\frac{1}{2\pi} \int_{\alpha}^{\pi+\alpha} I_{o(av)}^2 d\omega t} = I_{o(av)}$$

The average value of the supply current equal zero because its positive part area equal to its negative part. But the average for half cycle is equal to the average of load current.

The output power is given by:

$$P_o = I_{o(av)} V_{o(av)} = I_{o(rms)}^2 R$$

If the load circuit has an EMF the output average Power is given by:

$$P_o = I_{o(av)} V_{o(av)} = I_{o(rms)}^2 R + EI_{0(av)}$$

The input power factor is given by:

$$PF = \frac{P_o}{S_{in}} = \frac{I_{o(av)} V_{o(av)}}{V_s I_{s(rms)}}$$

## THREE PHASE CONTROLLED RECTIFIERS

### INTRODUCTION TO 3-PHASE CONTROLLED RECTIFIERS:

Single phase half controlled bridge converters & fully controlled bridge converters are used extensively in industrial applications up to about 15kW of output power. The single phase controlled rectifiers provide a maximum dc output of

The output ripple frequency is equal to the twice the ac supply frequency. The single phase full wave controlled rectifiers provide two output pulses during every input supply cycle and hence are referred to as two pulse converters.

Three phase converters are 3-phase controlled rectifiers which are used to convert ac input power supply into dc output power across the load.

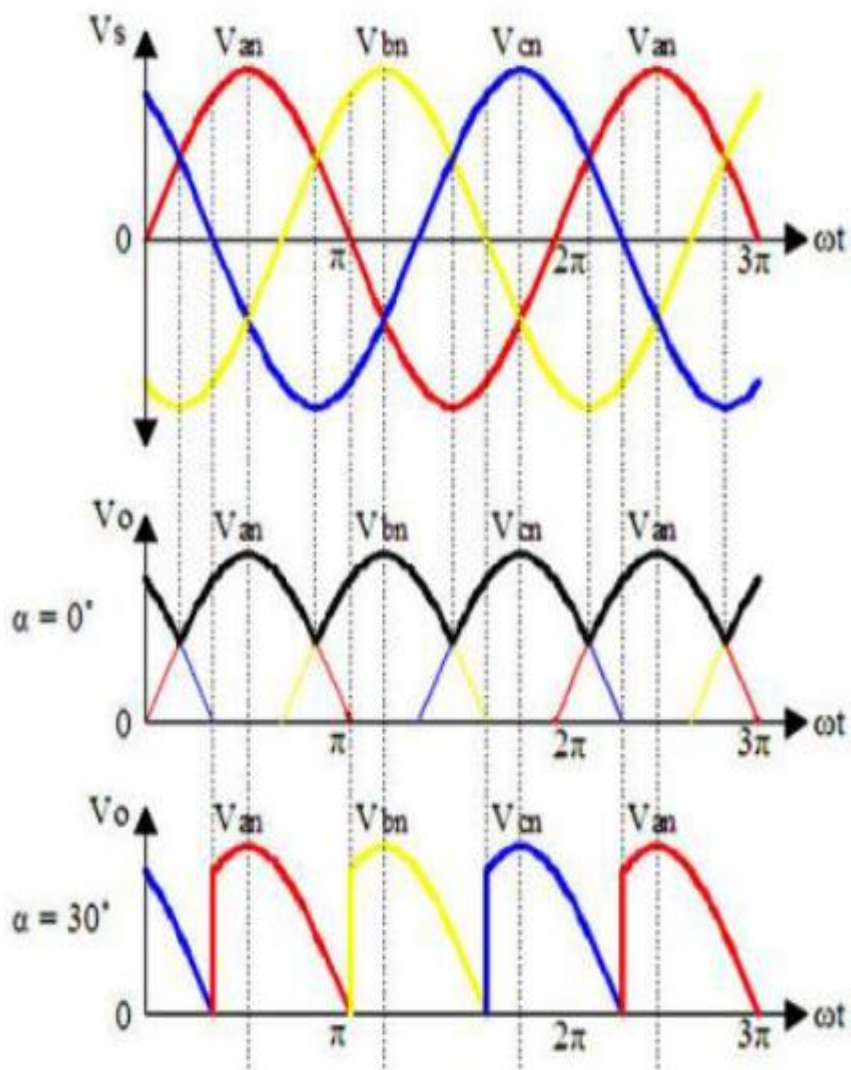
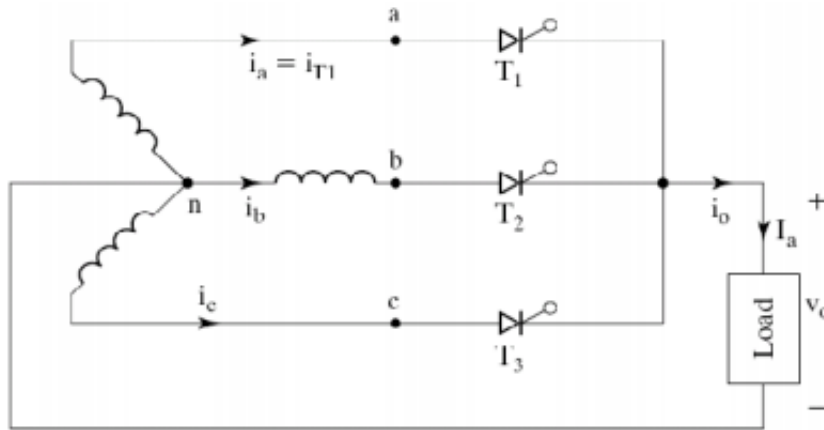
#### Features of 3-phase controlled rectifiers are

- Operate from 3 phase ac supply voltage.
- They provide higher dc output voltage and higher dc output power.
- Higher output voltage ripple frequency.
- Filtering requirements are simplified for smoothing out load voltage and load current

Three phase controlled rectifiers are extensively used in high power variable speed industrial dc drives.

### 3-PHASE HALF WAVE CONVERTER

Three single phase half-wave converters are connected together to form a three phase half-wave converter as shown in the figure.



### THEE PHASE SUPPLY VOLTAGE EQUATIONS

We define three line neutral voltages (3 phase voltages) as follows:

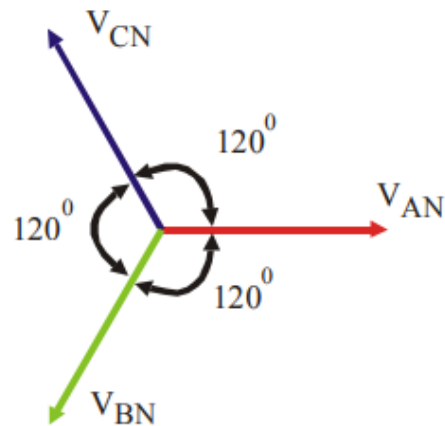
$$v_{RN} = v_{an} = V_m \sin \omega t; \quad V_m = \text{Max. Phase Voltage}$$

$$v_{YN} = v_{bn} = V_m \sin \left( \omega t - \frac{2\pi}{3} \right)$$

$$v_{YN} = v_{bn} = V_m \sin \left( \omega t - 120^\circ \right)$$

$$v_{BN} = v_{cn} = V_m \sin \left( \omega t + \frac{2\pi}{3} \right)$$

$$v_{BN} = v_{cn} = V_m \sin \left( \omega t + 120^\circ \right)$$



**Vector diagram of 3-phase supply voltages**

$$v_{BN} = v_{cn} = V_m \sin \left( \omega t - 240^\circ \right)$$

$$T_1 \text{ is triggered at } \omega t = \left( \frac{\pi}{6} + \alpha \right) = (30^\circ + \alpha)$$

$$T_2 \text{ is triggered at } \omega t = \left( \frac{5\pi}{6} + \alpha \right) = (150^\circ + \alpha)$$

$$T_3 \text{ is triggered at } \omega t = \left( \frac{7\pi}{6} + \alpha \right) = (270^\circ + \alpha)$$

Each thyristor conducts for  $120^\circ$  or  $\frac{2\pi}{3}$  radians

The 3-phase half wave converter combines three single phase half wave controlled rectifiers in one single circuit feeding a common load. The thyristor T1 in series with one of the supply phase acts as one half wave controlled rectifier. The second thyristor T2—windings ' ' a n in series with acts as the second half wave controlled rectifier. The third—the supply phase winding ' ' b n thyristor T3 acts as the third half wave controlled—in series with the supply phase winding ' ' c n rectifier. The 3-phase input supply is applied through the star connected supply transformer as shown in the figure. The common neutral point of the supply is connected to one end of the load while the other end of the load connected to the common cathode point. When the thyristor T1 is triggered at  $30+\alpha$  to  $150+\alpha$  , the phase voltage  $V_{an}$  appears across the load when T1 conducts. The load current flows through the supply phase and through thyristor T1—winding ' ' a n as long as T1 conducts. When thyristor T2 is triggered at  $150+\alpha$  to  $270 + \alpha$  , T1 becomes reverse biased and turns-off. The load current flows through the thyristor T2 and through the supply phase . When T2—winding ' ' b n conducts the

phase voltage  $v_{bn}$  appears across the load until the thyristor T3 is triggered. When the thyristor T3 is triggered at  $270^\circ + \alpha$  to  $390^\circ + \alpha$ , T2 is reverse biased and hence T2 turns-off. The phase voltage  $v_{cn}$  appears across the load when T3 conducts. When T1 is triggered again at the beginning of the next input cycle the thyristor T3 turns off as it is reverse biased naturally as soon as T1 is triggered. The figure shows the 3-phase input supply voltages, the output voltage which appears across the load.

**Load current is always continuous. The dc component of the output voltage is the average value, and load current is the resistor voltage divided by resistance.**

$$V_{dc} = \frac{3}{2\pi} \int_{\frac{\pi}{6} + \alpha}^{\frac{5\pi}{6} + \alpha} V_m \sin \omega t \, d\omega t = \frac{3\sqrt{3}V_m \cos \alpha}{2\pi}$$

$$I_{dc} = \frac{V_{dc}}{R} = \frac{3\sqrt{3}V_m \cos \alpha}{2\pi R}$$

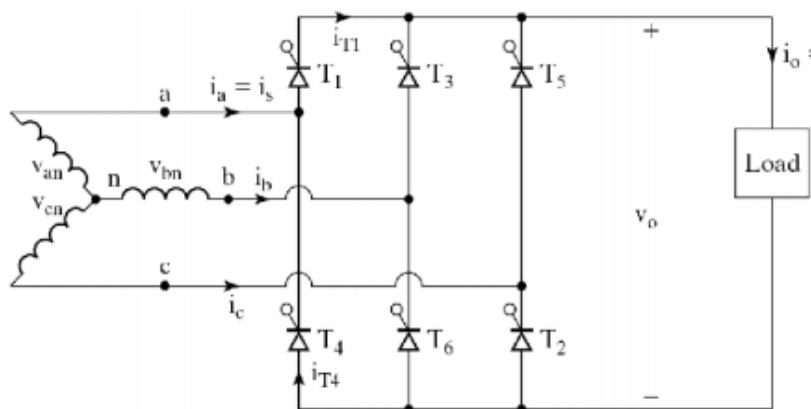
**The *rms* component of the output voltage and current waveforms are determined from**

$$V_{rms} = \sqrt{\frac{3}{2\pi} \int_{\frac{\pi}{6} + \alpha}^{\frac{5\pi}{6} + \alpha} (V_m \sin \omega t)^2 \, d\omega t} = \sqrt{3}V_m \sqrt{\frac{1}{6} + \frac{\sqrt{3}}{8\pi} \cos 2\alpha}$$

$$I_{rms} = \frac{V_{rms}}{\sqrt{R^2 + (\omega L)^2}} = \frac{\sqrt{3}V_m}{\sqrt{R^2 + (\omega L)^2}} \sqrt{\frac{1}{6} + \frac{\sqrt{3}}{8\pi} \cos 2\alpha}$$

### THREE PHASE FULL CONVERTER

Three phase full converter is a fully controlled bridge controlled rectifier using six thyristors connected in the form of a full wave bridge configuration. All the six thyristors are controlled switches which are turned on at a appropriate times by applying suitable gate trigger signals. The three phase full converter is extensively used in industrial power applications upto about 120kW output power level, where two quadrant operation is required. The figure shows a three phase full converter with highly inductive load. This circuit is also known as three phase full wave bridge or as six pulse converter. The thyristors are triggered at an interval of  $\pi/3$  radians (i.e. at an interval of  $60^\circ$ ). The frequency of output ripple voltage is  $6 f_s$  and the filtering requirement is less than that of three phase semi and half wave converters.



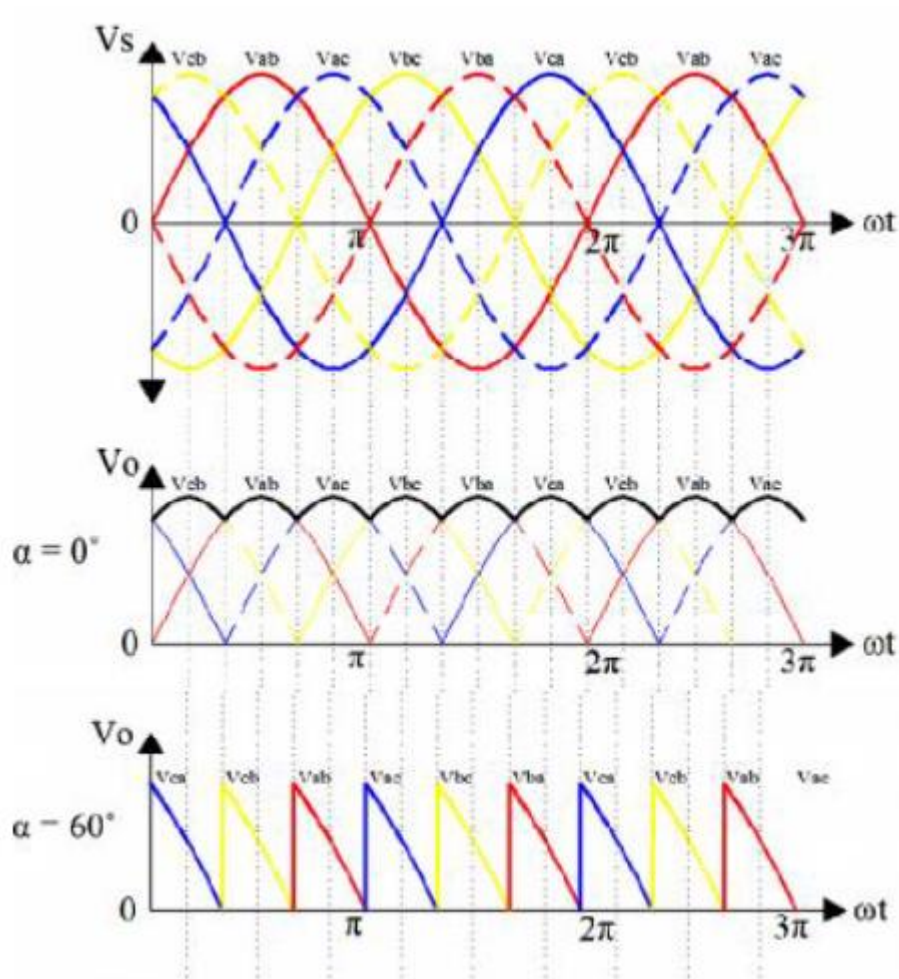
- The three thyristors (T1,T3 andT5) will not work together at the same time or two of them also will not work together at the same time.
- The three thyristors (T2,T4 andT6) will not work together at the same time or two of them also will not work together at the same time.
- (T1 and T4), (T3 and T6) or (T5 and T2) will not work together at the same time.
- Each thyristor is triggered at an interval of  $2\pi/3$ .
- Each thyristors pair ((T6&T1), (T1&T2), (T2&T3), (T3&T4), (T4&T5), (T5&T6)) is triggered at an interval of  $\pi/3$ .
- If T1 is triggered at  $(30 + \alpha)$ , T3 will be triggered at  $(30 + \alpha+120)$  and T5 will be triggered at  $(30 + \alpha+240)$ . T4 will be triggered at  $(30 + \alpha+180)$ , T6 will be triggered at  $(30 + \alpha+120+180)$  and T2 will be triggered at  $(30 + \alpha+240+180)$ .

Firing Angle	T <sub>1</sub>	T <sub>2</sub>	T <sub>3</sub>	T <sub>4</sub>	T <sub>5</sub>	T <sub>6</sub>
0°	30°	90	150°	210	270°	330
30°	60°	120°	180°	240°	300°	360°
60°	90°	150°	210°	270°	330°	390°
90°	120°	180°	240°	300°	360°	420°

- Thyristor T1 and T2 conduct together and the line to line supply voltage ac v appears across the load. The thyristors are numbered in the circuit diagram corresponding to the order in which they are triggered. The trigger sequence (firing sequence) of the thyristors is 12, 23, 34, 45, 56, 61, 12, 23, and so on. The figure shows the waveforms of three phase input supply voltages, output voltage, the thyristor current through T1 and T4 , the supply current through the line 'a'.
- T1 is triggered at  $\omega t = (30 + \alpha)$ , T6 is already conducting when T1 is turned ON.
- During the interval  $(30 + \alpha)$  to  $(90 + \alpha)$ , T1 and T6 conduct together & the output load voltage is equal to  $v_o = v_{ab} = (v_{an} - v_{bn})$ .
- T2 is triggered at  $\omega t = (90 + \alpha)$ , T6 turns off naturally as it is reverse biased as soon as T2 is triggered. During the interval  $(90 + \alpha)$  to  $(150 + \alpha)$ , T1 and T2 conduct together & the output load voltage  $v_o = v_{ac} = (v_{an} - v_{cn})$ .
- T3 is triggered at  $\omega t = (150 + \alpha)$ , T1 turns off naturally as it is reverse biased as soon as T3 is triggered. During the interval  $(150 + \alpha)$  to  $(210 + \alpha)$ , T2 and T3 conduct together & the output load voltage  $v_o = v_{bc} = (v_{bn} - v_{cn})$ .
- T4 is triggered at  $\omega t = (210 + \alpha)$ , T2 turns off naturally as it is reverse biased as soon as T4 is triggered. During the interval  $(210 + \alpha)$  to  $(270 + \alpha)$ , T3 and T4 conduct together & the output load voltage  $v_o = v_{ba} = (v_{bn} - v_{an})$ .
- T5 is triggered at  $\omega t = (270 + \alpha)$ , T3 turns off naturally as it is reverse biased as soon as T5 is triggered. During the interval  $(270 + \alpha)$  to  $(230 + \alpha)$ , T4 and T5 conduct together & the output load voltage  $v_o = v_{ca} = (v_{cn} - v_{an})$ .



- T6 is triggered at  $\omega t = (330 + \alpha)$ , T4 turns off naturally as it is reverse biased as soon as T6 is triggered. During the interval  $(330 + \alpha)$  to  $(390 + \alpha)$ , T5 and T6 conduct together & the output load voltage  $v_o = v_{cb} = (v_{cn} - v_{bn})$ .



The output load voltage consists of 6 voltage pulses over a period of  $2\pi$  radians, hence the average output voltage is calculated as

$$V_{O(dc)} = V_{dc} = \frac{6}{2\pi} \int_{\frac{\pi}{6} + \alpha}^{\frac{\pi}{2} + \alpha} v_o \cdot d\omega t \quad ;$$

$$v_o = v_{ab} = \sqrt{3}V_m \sin\left(\omega t + \frac{\pi}{6}\right)$$

$$V_{dc} = \frac{3}{\pi} \int_{\frac{\pi}{6} + \alpha}^{\frac{\pi}{2} + \alpha} \sqrt{3}V_m \sin\left(\omega t + \frac{\pi}{6}\right) \cdot d\omega t$$

$$V_{dc} = \frac{3\sqrt{3}V_m}{\pi} \cos \alpha = \frac{3V_{ml}}{\pi} \cos \alpha$$

Where  $V_{ml} = \sqrt{3}V_m = \text{Max. line-to-line supply voltage}$



The maximum average dc output voltage is obtained for a delay angle  $\alpha = 0$ ,

$$V_{dc(\max)} = V_{dm} = \frac{3\sqrt{3}V_m}{\pi} = \frac{3V_{mL}}{\pi}$$

The normalized average dc output voltage is

$$V_{dcn} = V_n = \frac{V_{dc}}{V_{dm}} = \cos \alpha$$

The rms value of the output voltage is found from

$$V_{O(rms)} = \left[ \frac{6}{2\pi} \int_{\frac{\pi}{6} + \alpha}^{\frac{\pi}{2} + \alpha} v_o^2 \cdot d(\omega t) \right]^{\frac{1}{2}}$$

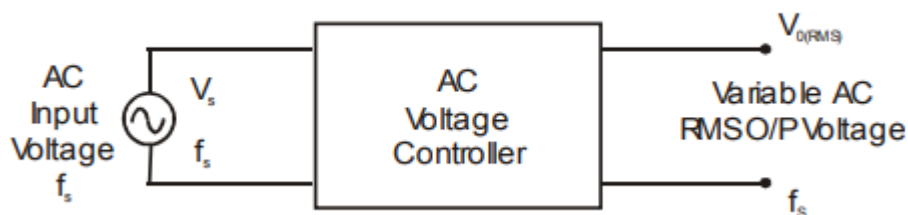
$$V_{O(rms)} = \left[ \frac{6}{2\pi} \int_{\frac{\pi}{6} + \alpha}^{\frac{\pi}{2} + \alpha} v_{ab}^2 \cdot d(\omega t) \right]^{\frac{1}{2}}$$

$$V_{O(rms)} = \left[ \frac{3}{2\pi} \int_{\frac{\pi}{6} + \alpha}^{\frac{\pi}{2} + \alpha} 3V_m^2 \sin^2 \left( \omega t + \frac{\pi}{6} \right) \cdot d(\omega t) \right]^{\frac{1}{2}}$$

$$V_{O(rms)} = \sqrt{3}V_m \left( \frac{1}{2} + \frac{3\sqrt{3}}{4\pi} \cos 2\alpha \right)^{\frac{1}{2}}$$

## AC VOLTAGE CONTROLLER CIRCUITS

AC voltage controllers (ac line voltage controllers) are employed to vary the RMS value of the alternating voltage applied to a load circuit by introducing Thyristors between the load and a constant voltage ac source. The RMS value of alternating voltage applied to a load circuit is controlled by controlling the triggering angle of the Thyristors in the ac voltage controller circuits. In brief, an ac voltage controller is a type of thyristor power converter which is used to convert a fixed voltage, fixed frequency ac input supply to obtain a variable voltage ac output. The RMS value of the ac output voltage and the ac power flow to the load is controlled by varying (adjusting) the trigger angle ' $\alpha$ '.

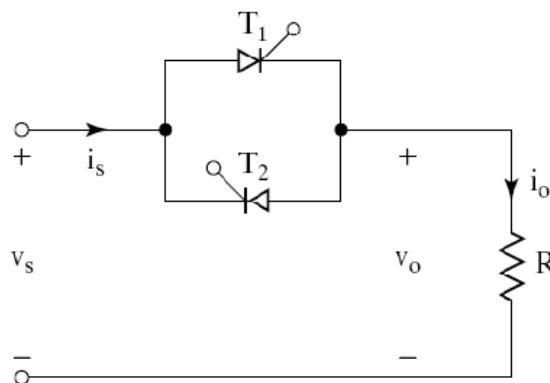


## SINGLE PHASE FULL WAVE AC VOLTAGE CONTROLLER (AC REGULATOR) OR RMS VOLTAGE CONTROLLER WITH RESISTIVE LOAD :

Single phase full wave ac voltage controller circuit using two SCRs or a single triac is generally used in most of the ac control applications. The ac power flow to the load can be controlled in both the half cycles by varying the trigger angle. " $\alpha$ "

The RMS value of load voltage can be varied by varying the trigger angle . The input supply current is alternating in the case of a full wave ac voltage controller and due to the symmetrical nature of the input supply current waveform there is no dc component of input supply current i.e., the average value of the input supply current is zero. " $\alpha$ "

A single phase full wave ac voltage controller with a resistive load is shown in the figure below. It is possible to control the ac power flow to the load in both the half cycles by adjusting the trigger angle. Hence the full wave ac voltage controller is also referred to as to a bi-directional controller. " $\alpha$ "

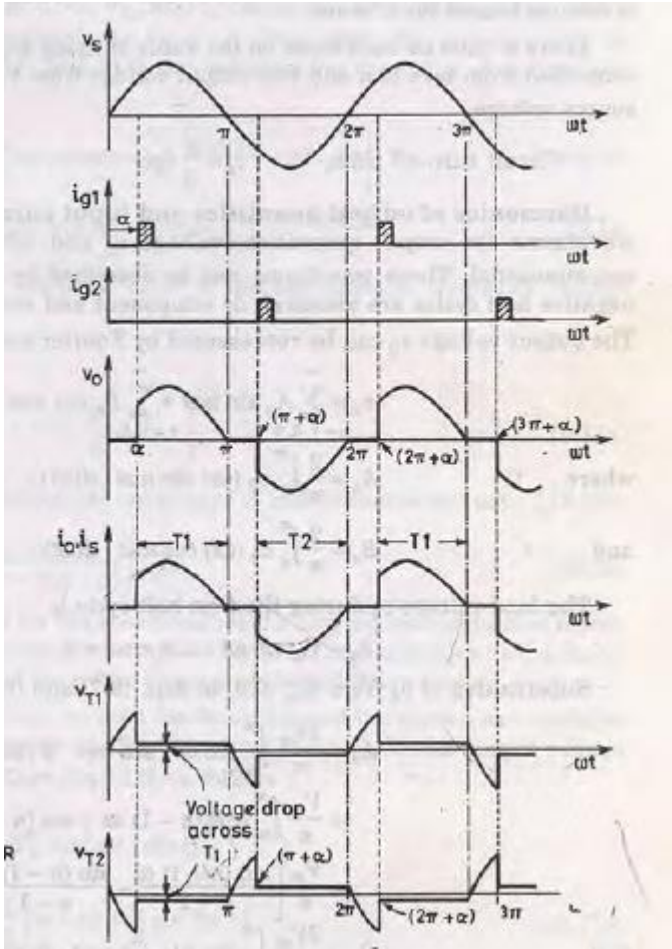


**Fig.: Single phase full wave ac voltage controller (Bi-directional Controller) using SCRs**

The thyristor T1 is forward biased during the positive half cycle of the input supply voltage. The thyristor T1 is triggered at a delay angle of " $\alpha$ " ( $0 \leq \alpha \leq \pi$ ). Considering the ON thyristor T1 as an ideal closed switch the input supply voltage appears across the load resistor  $R_L$  and the output  $V_o = V_s$  voltage during  $\omega t = \alpha$  to  $\pi$  radians. The load current flows through the ON thyristor T1 and through the load resistor  $R_L$  in the downward direction during the conduction time of T1 from  $\omega t = \alpha$  to  $\pi$  radians.

At  $\omega t = \pi$ , when the input voltage falls to zero the thyristor current (which is flowing through the load resistor  $R_L$ ) falls to zero and hence T1 naturally turns off . No current flows in the circuit during to  $\omega t = \pi$  to  $(\pi + \alpha)$ .

The thyristor T2 is forward biased during the negative cycle of input supply and when thyristor T2 is triggered at a delay angle  $(\pi + \alpha)$  , the output voltage follows the negative half cycle of input from  $\omega t = (\pi + \alpha)$  to  $2\pi$  . When T2 is ON, the load current flows in the reverse direction (upward direction) through during  $\omega t = (\pi + \alpha)$  to  $2\pi$  radians. The time interval (spacing) between the gate trigger pulses of T1 and T2 is kept at  $\pi$  radians or  $180^\circ$ . At  $\omega t = 2\pi$  the input supply voltage falls to zero and hence the load current also falls to zero and thyristor T2 turn off naturally.



RMS OUTPUT VOLTAGE:

$$\begin{aligned}
 E_{ORMS} &= \left[ \frac{2}{2\pi} \int_{\alpha}^{\pi} E_m^2 \sin^2 \omega t \, d\omega t \right]^{1/2} \\
 &= \left[ \frac{E_m^2}{\pi} \int_{\alpha}^{\pi} \left( \frac{1 - \cos 2\omega t}{2} \right) \right]^{1/2} \\
 &= \frac{E_m}{\sqrt{\pi}} \left[ \frac{1}{2} (\pi - \alpha) - \frac{1}{2 \times 2} (\sin 2\omega t)_{\alpha}^{\pi} \right]^{1/2} \\
 &= \frac{E_m}{\sqrt{2\pi}} \left[ \pi - \alpha + \frac{1}{2} \sin 2\alpha \right]^{1/2} \\
 &= \frac{E_s}{\sqrt{\pi}} \left[ \pi - \alpha + \frac{1}{2} \sin 2\alpha \right]^{1/2} \left( \because E_s = \frac{E_m}{\sqrt{2}} \right)
 \end{aligned}$$

$$E_{ORMS} = \frac{E_s}{\sqrt{\pi}} \left[ \pi - \alpha + \frac{\sin 2\alpha}{2} \right]^{1/2}$$

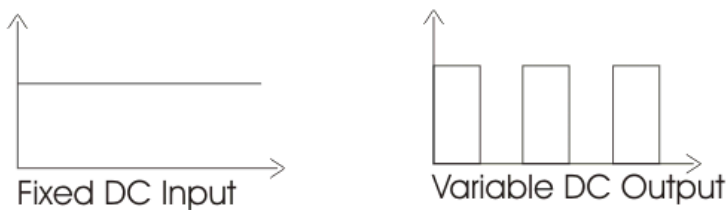
RMS load current may be given as

$$I_{ORMS} = \frac{E_{ORMS}}{R}$$

$$\text{Power delivered to the load} = \frac{E_{ORMS}^2}{R}$$

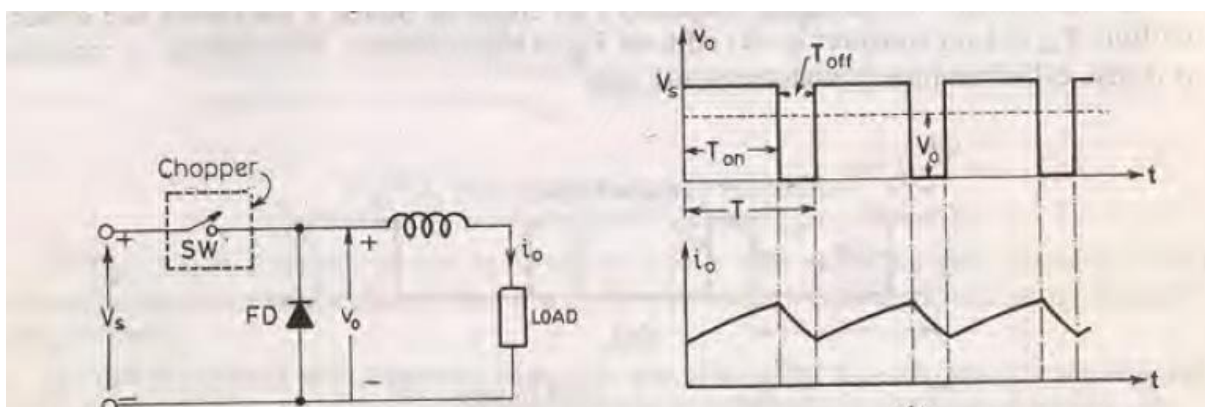
# CHOPPER

**DC to DC converter** is very much needed nowadays as many industrial applications are dependent upon DC voltage source. The performance of these applications will be improved if we use a variable DC supply. It will help to improve controllability of the equipments also. Examples of such applications are subway cars, trolley buses, battery operated vehicles etc. We can control and vary a constant DC voltage with the help of a **chopper**. Chopper is a basically static power electronics device which converts fixed DC voltage/power to variable DC voltage or power. It is nothing but a high speed switch which connects and disconnects the load from source at a high rate to get variable or chopped voltage at the output.



## STEP DOWN CHOPPER:

Step down chopper as Buck converted is used to reduce the i/p voltage level at the output side. Circuit diagram of a step down chopper is shown in the adjacent figure.



When CH is turned ON,  $V_s$  directly appears across the load as shown in figure. So  $V_o = V_s$ .

When CH is turned off,  $V_s$  is disconnected from the load. So output voltage  $V_o = 0$ .

$T_{ON}$  → It is the interval in which chopper is in ON state.  
 $T_{OFF}$  → It is the interval in which chopper is in OFF state.  
 $V_s$  → Source or input voltage.  
 $V_o$  → Output or load voltage.  
 $T$  → Chopping period =  $T_{ON} + T_{OFF}$

### Operation Of Step Down Chopper with Inductive Load

When CH is ON,  $V_o = V_s$   
 When CH is OFF,  $V_o = 0$

#### During ON time of Chopper

$$V_s = V_L + V_o \Rightarrow V_L = V_s - V_o \Rightarrow L \frac{di}{dt} = V_s - V_o \Rightarrow L \frac{\Delta I}{T_{ON}} = V_s - V_o$$

Therefore, peak to peak load current,

Therefore, peak to peak load current,

$$\Delta I = \frac{V_s - V_o}{L} T_{ON} \dots \dots \dots (i)$$

#### During OFF Time of Chopper

If inductance value of L is very large, so load current will be continuous in nature. When CH is OFF inductor reverses its polarity and discharges. This current freewheels through diode FD.

Therefore,  $L \frac{di}{dt} = V_o$

$$L \frac{\Delta I}{T_{OFF}} = V_o \Rightarrow \Delta I = V_o \frac{T_{OFF}}{L} \dots \dots \dots (ii)$$

By equating (i) and (ii)

$$\frac{V_s - V_o}{L} T_{ON} = \frac{V_o}{L} T_{OFF}$$

$$\frac{V_s - V_o}{V_o} = \frac{T_{OFF}}{T_{ON}}$$

$$\frac{V_s}{V_o} = \frac{T_{ON} - T_{OFF}}{T_{ON}}$$

Therefore,  $V_o = \frac{T_{ON}}{T} V_s = DV_s$

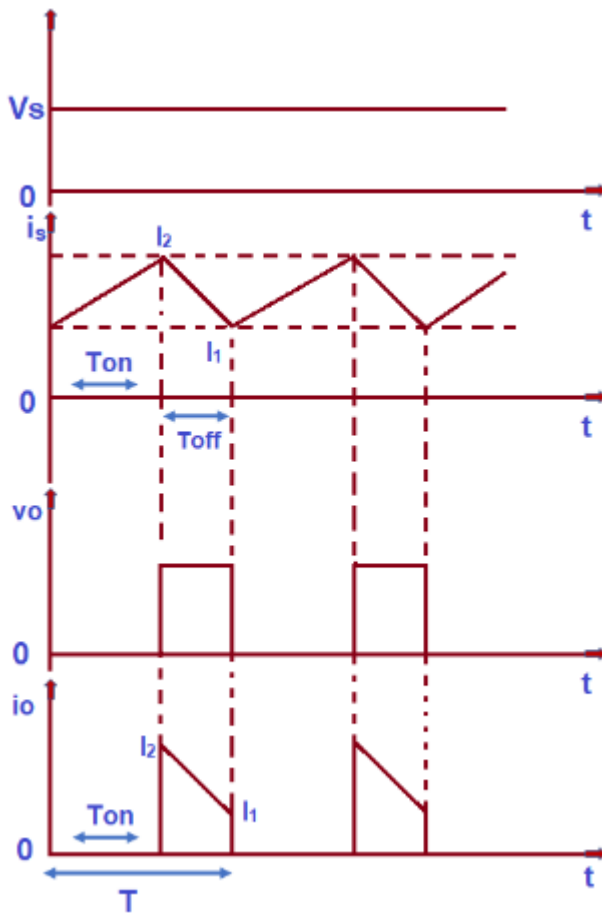
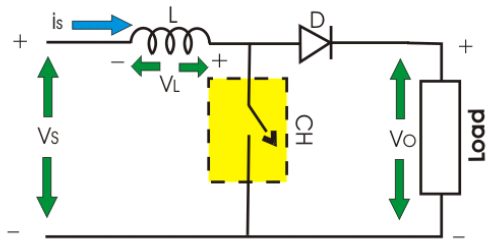
Where, D is duty cycle =  $T_{ON}/T$ .

Duty cycle is the ratio of Ton time to Total time period. It is also denoted as “α”.

So, we can conclude that output voltage is always less than the input voltage and hence the name step down chopper is justified.

#### Step up Chopper or Boost Converter :

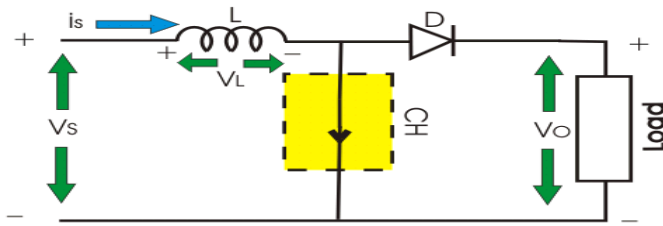
Step up chopper or boost converter is used to increase the input voltage level of its output side. Its circuit diagram and waveforms are shown below



### Operation of Step up Chopper

When CH is ON it short circuits the load. Hence output voltage during  $T_{ON}$  is zero. During this period inductor gets charged. So,  $V_s = V_L$

$$L \frac{di}{dt} = V_s \Rightarrow \frac{\Delta I}{T_{ON}} = \frac{V_s}{L} \Rightarrow \Delta I = \frac{V_s}{L} T_{ON} \dots (iii)$$

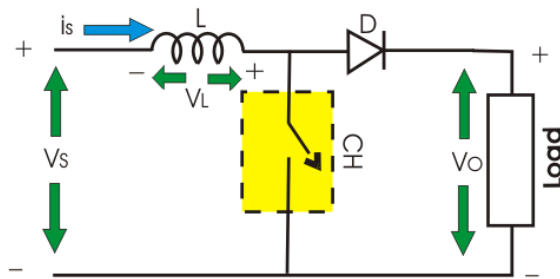


Where,  $\Delta I$  is the peak to peak inductor current.

When CH is OFF inductor L discharges through the load. So, we will get summation of both source voltage  $V_s$  and inductor Voltage  $V_L$  as output voltage, i.e.

$$V_o = V_s + V_L \Rightarrow V_L = V_o - V_s \Rightarrow L \frac{di}{dt} = V_o - V_s$$

$$\Rightarrow L \frac{\Delta I}{T_{OFF}} = V_o - V_s \Rightarrow \Delta I = \frac{V_o - V_s}{L} T_{OFF} \dots (iv)$$



Now, by equating (iii) and (iv),

$$\frac{V_s T_{ON}}{L} = \frac{V_o - V_s}{L} T_{OFF} \Rightarrow V_s (T_{ON} + T_{OFF}) = V_o T_{OFF}$$

$$\Rightarrow V_o = \frac{T V_s}{T_{OFF}} = \frac{V_s}{(T - T_{ON})/T}$$

$$\text{Therefore, average output voltage, } V_o = \frac{V_s}{1 - D}$$

As we can vary TON from 0 to T, so  $0 \leq D \leq 1$ . Hence  $V_o$  can be varied from  $V_s$  to  $\infty$ . It is clear that output voltage is always greater than the input voltage and hence it boost up or increase the voltage level.

## Control Strategy of Chopper:

In DC-DC converters, the average output voltage is controlled by varying the alpha ( $\alpha$ ) value. This is achieved by varying the Duty Cycle of the switching pulses. Duty cycle can be varied usually in 2 ways:



1. Time Ratio Control
2. Current Limit Control

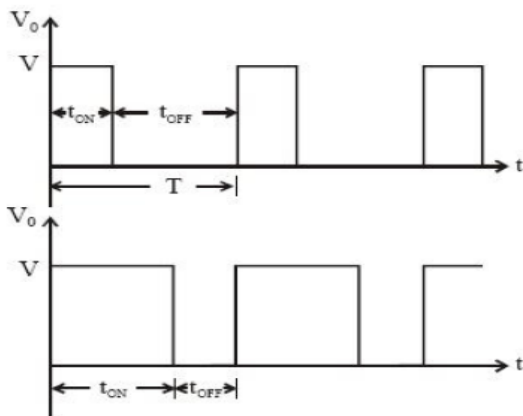
#### Time Ratio Control:

As the name suggest, here the time ratio (i.e. the duty cycle ratio  $T_{on}/T$ ) is varied. This kind of control can be achieved using 2 ways:

- Constant frequency control (Pulse Width Modulation (PWM))
- Variable Frequency Control (Frequency Modulation Control (FMC))

#### Constant frequency control /Pulse Width Modulation (PWM):

In this technique, the time period is kept constant, but the 'On Time' or the 'OFF Time' is varied. Using this, the duty cycle ratio can be varied. Since the ON time or the 'pulse width' is getting changed in this method, so it is popularly known as Pulse width modulation.

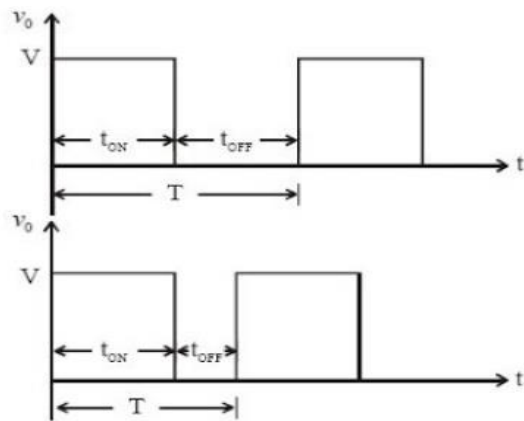


Pulse Width Modulation

#### Variable Frequency Control /Frequency Modulation Control (FMC):

In this control method, the 'Time Period' is varied while keeping either of 'On Time' or 'OFF time' as constant. In this method, since the time period gets changed, so the frequency also changes

accordingly, so this method is known as frequency modulation control.



Frequency Modulation Control

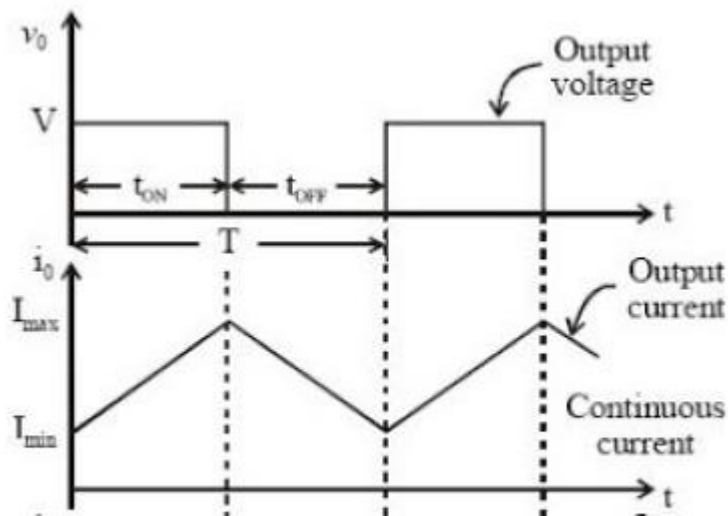
**The disadvantages of Control Strategy include the following:**

- The frequency has to be changed over an extensive range of the o/p voltage control in FM (frequency modulation). The design of the filter for wide frequency change is quite difficult.
- For the duty cycle ration control. Frequency change would be varied. As such, there is a possibility of intrusion with systems by positive frequencies like telephone lines and signaling in frequency modulation (FM) technique.
- The huge OFF time in FM (frequency modulation) technique may make the load current irregular, which is unwanted.
- Therefore, the constant frequency system with pulse width modulation is preferred for choppers or DC-DC converters.

**Current Limit Control:**

- As is obvious from its name, in this control strategy, a specific limit is applied on the current variation.
- In this method, current is allowed to fluctuate or change only between 2 values i.e. maximum current ( $I_{max}$ ) and minimum current ( $I_{min}$ ). When the current is at minimum value, the chopper is switched ON. After this instance, the current starts increasing, and when it reaches up to maximum value, the chopper is switched off allowing the current to fall back to minimum value.

- This cycle continues again and again.



Current Limit Control

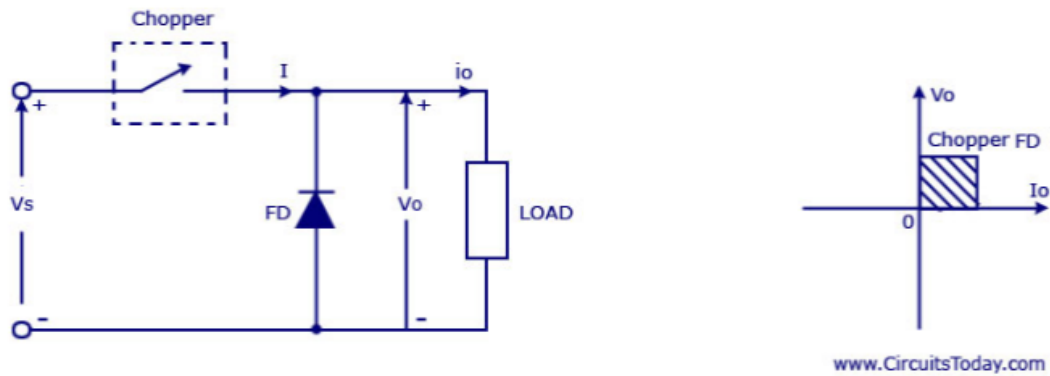
## Types of Chopper Circuits

In power electronics [chopper circuits](#), unidirectional power semiconductor devices are used. If these semiconductor devices are arranged appropriately, a chopper can work in any of the four quadrants. we can classify chopper circuits according to their working in any of these four quadrants as type A, type B, type C, type D and type E. Let us now take a look of these classifications and the characteristics of various classifications.

### *Type A Chopper or First-Quadrant Chopper*

This type of chopper is shown in the figure. It is known as first-quadrant chopper or type A chopper. When the chopper is on,  $v_o = V_s$  as a result and the current flows in the direction of the load. But when the chopper is off  $v_o$  is zero but  $i_o$  continues to flow in the same direction through the freewheeling diode FD, thus average value of voltage and current say  $V_o$  and  $I_o$  will be always positive as shown in the graph.

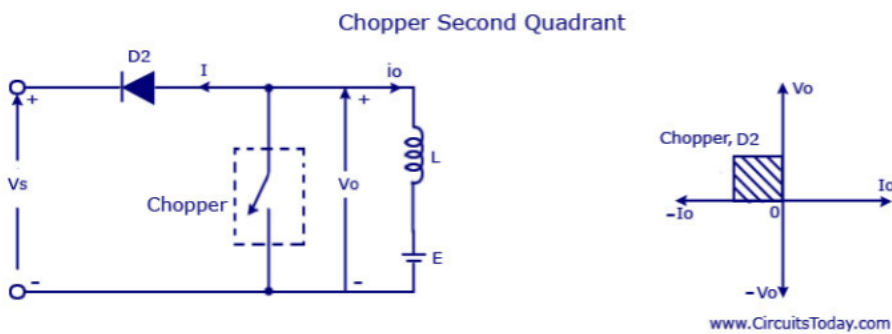
### Chopper First Quadrant



Chopper First Quadrant

In type A chopper the power flow will be always from source to the load. As the average voltage  $V_o$  is less than the dc input voltage  $V_s$ -

### Type B Chopper or Second-Quadrant Chopper



Chopper Second Quadrant

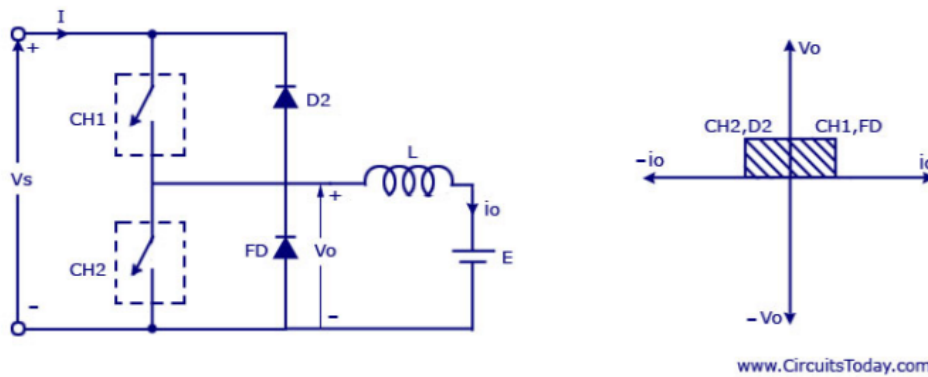
In type B or second quadrant chopper the load must always contain a dc source  $E$ . When the chopper is on,  $v_o$  is zero but the load voltage  $E$  drives the current through the inductor  $L$  and the chopper,  $L$  stores the energy during the time  $T_{on}$  of the chopper. When the chopper is off,  $v_o = (E + L \cdot di/dt)$  will be more than the source voltage  $V_s$ . Because of this the diode  $D_2$  will be forward biased and begins conducting and hence the power starts flowing to the source. No matter the chopper is on or off the current  $I_o$  will be flowing out of the load and is treated negative. Since  $V_o$  is positive and the current  $I_o$  is negative, the direction of power flow will be from load to source. The load voltage  $V_o = (E + L \cdot di/dt)$  will be more than the voltage  $V_s$  so the type B chopper is also known as a step up chopper.

### Type -C chopper or Two-quadrant type-A Chopper

Type C chopper is obtained by connecting type -A and type -B choppers in parallel. We will always get a positive output voltage  $V_o$  as the freewheeling diode FD is present across the load. When the chopper is on the freewheeling diode starts conducting and the output voltage  $v_o$  will be equal to

$V_s$ . The direction of the load current  $i_o$  will be reversed. The current  $i_o$  will be flowing towards the source and it will be positive regardless the chopper is on or the FD conducts. The load current will be negative if the chopper is or the diode D2 conducts. We can say the chopper and FD operate together as type-A chopper in first quadrant. In the second quadrant, the chopper and D2 will operate together as type -B chopper.

Chopper Two Quadrant

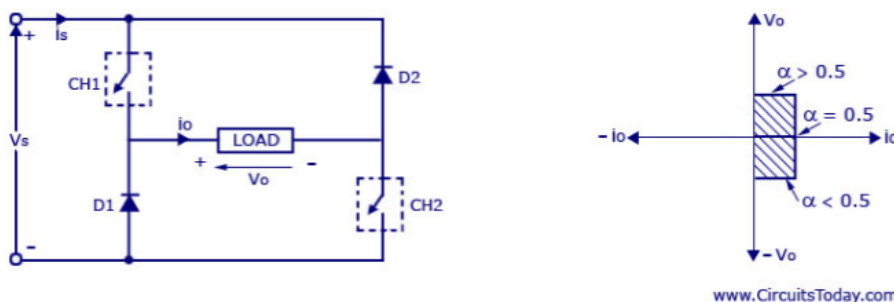


Chopper Two Quadrant

The average voltage will be always positive but the average load current might be positive or negative. The power flow may be like the first quadrant operation i.e. from source to load or from load to source like the second quadrant operation. The two choppers should not be turned on simultaneously as the combined action may cause a short circuit in supply lines. For regenerative braking and motoring these type of chopper configuration is used.

Type D Chopper or Two-Quadrant Type -B Chopper

Two Quadrant Type B-chopper or D-chopper Circuit



Two Quadrant Type B chopper or D Chopper Circuit

The circuit diagram of the type D chopper is shown in the above figure. When the two choppers are on the output voltage  $v_o$  will be equal to  $V_s$ . When  $v_o = -V_s$  the two choppers will be off but both the diodes D1 and D2 will start conducting.  $V_o$  the average output voltage will be positive when the choppers turn-on the time  $T_{on}$  will be more than the turn off time  $T_{off}$  its shown in the wave form

below. As the diodes and choppers conduct current only in one direction the direction of load current will be always positive.

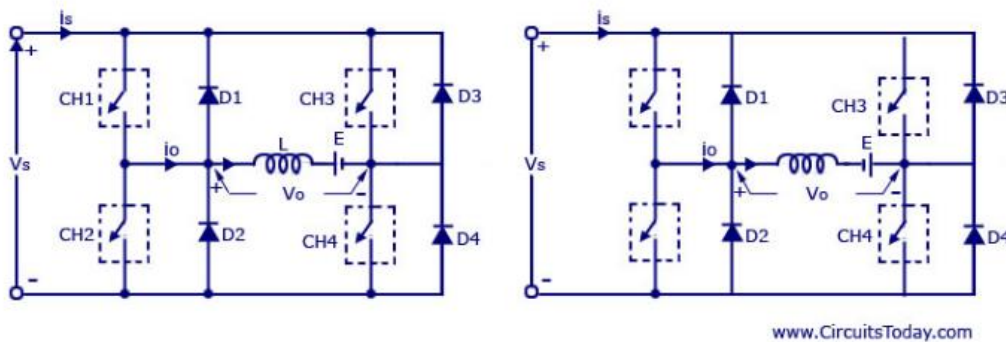
The power flows from source to load as the average values of both  $v_o$  and  $i_o$  is positive. From the wave form it is seen that the average value of  $V_o$  is positive thus the fourth quadrant operation of type D chopper is obtained.

From the wave forms the Average value of output voltage is given by  $V_o = (V_s T_{on} - V_s T_{off}) / T = V_s \cdot (T_{on} - T_{off}) / T$

### Type –E chopper or the Fourth-Quadrant Chopper

Type E or the fourth quadrant chopper consists of four semiconductor switches and four diodes arranged in antiparallel. The 4 choppers are numbered according to which quadrant they belong. Their operation will be in each quadrant and the corresponding chopper only be active in its quadrant.

E-type Chopper Circuit Diagram With Load emf E and E Reversed



E-type Chopper Circuit diagram with load emf E and E Reversed

- **First Quadrant**

During the first quadrant operation the chopper CH4 will be on . Chopper CH3 will be off and CH1 will be operated. AS the CH1 and CH4 is on the load voltage  $v_o$  will be equal to the source voltage  $V_s$  and the load current  $i_o$  will begin to flow .  $v_o$  and  $i_o$  will be positive as the first quadrant operation is taking place. As soon as the chopper CH1 is turned off, the positive current freewheels through CH4 and the diode D2 . The type E chopper acts as a step- down chopper in the first quadrant.

- **Second Quadrant**

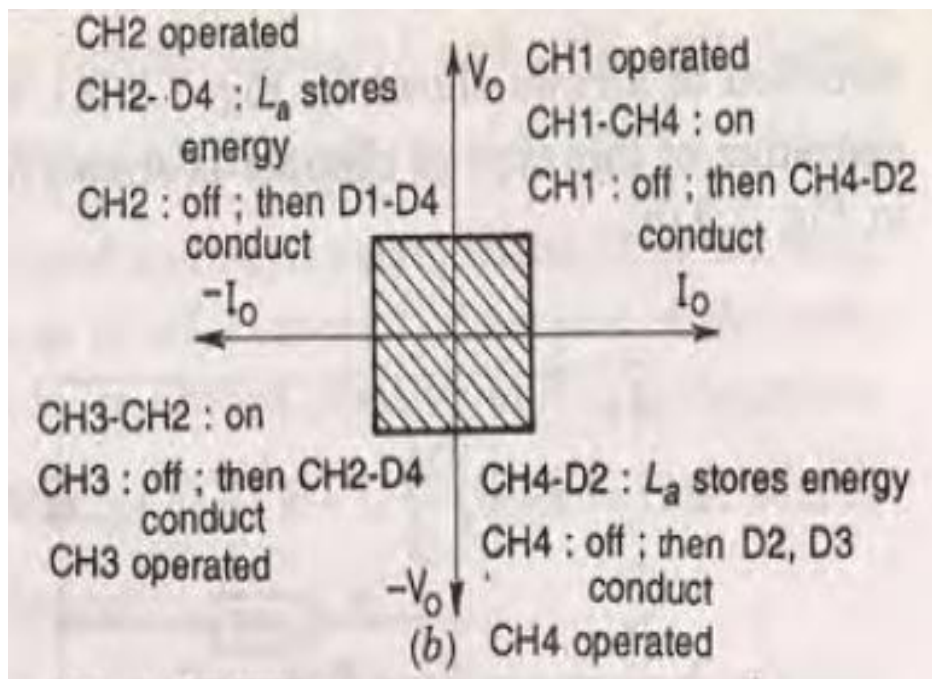
In this case the chopper CH2 will be operational and the other three are kept off. As CH2 is on negative current will starts flowing through the inductor L . CH2 ,E and D4. Energy is stored in the inductor L as the chopper CH2 is on. When CH2 is off the current will be fed back to the source through the diodes D1 and D4. Here  $(E + L \cdot di/dt)$  will be more than the source voltage  $V_s$  . In second quadrant the chopper will act as a step-up chopper as the power is fed back from load to source.

- **Third Quadrant**

In third quadrant operation CH1 will be kept off, CH2 will be on and CH3 is operated. For this quadrant working the polarity of the load should be reversed. As the chopper CH3 is on, the load gets connected to the source  $V_s$  and  $v_o$  and  $i_o$  will be negative and the third quadrant operation will take place. This chopper acts as a step-down chopper.

- **Fourth Quadrant**

CH4 will be operated and CH1, CH2 and CH3 will be off. When the chopper CH4 is turned on positive current starts to flow through CH4, D2, E and the inductor L will store energy. As the CH4 is turned off the current is feedback to the source through the diodes D2 and D3, the operation will be in fourth quadrant as the load voltage is negative but the load current is positive. The chopper acts as a step up chopper as the power is fed back from load to source.



## Chapter-3

### **UNDERSTAND THE INVERTERS AND CYCLO-CONVERTER:**

#### **INTRODUCTION:**

**Alternating Current (AC)** power supply is used for almost all the residential, commercial and industrial needs. But the biggest issue with AC is that it cannot be stored for future use. So AC is converted into DC and then DC is stored in batteries and ultra-capacitors. And now whenever AC is needed, DC is again converted into AC to run the AC based appliances. So the **device which converts DC into AC is called Inverter**. The inverter is used to convert DC to variable AC. This variation can be in the magnitude of voltage, number of phases, frequency or phase difference.

#### Classification of Inverter

Inverter can be classified into many types based on output, source, type of load etc. Below is the complete classification of the inverter circuits:

##### **(I) According to the Output Characteristic**

1. Square Wave Inverter
2. Sine Wave Inverter
3. Modified Sine Wave Inverter

##### **(II) According to the Source of Inverter**

1. Current Source Inverter
2. Voltage Source Inverter

##### **(III) According to the Type of Load**

1. SinglePhaseInverter
  - a) Half Bridge Inverter
  - b) Full Bridge Inverter
2. ThreePhaseInverter
  - a) 180-degree mode
  - b) 120-degree mode

##### **(IV) According to different PWM Technique**

1. Simple Pulse Width Modulation (SPWM)
2. Multiple Pulse Width Modulation (MPWM)
3. Sinusoidal Pulse Width Modulation (SPWM)
4. Modified sinusoidal Pulse Width Modulation (MSPWM)

##### **(V) According to Number of Output Level**

1. Regular Two-Level Inverter
2. Multi-Level Inverter

(VI) According to connection of commutating element with main circuit:



1. Series inverter
2. parallel inverter
3. Bridge inverter

### Series Inverter ( Load Commutated Inverter or Self Commutated Inverter )

- The commutating components L and C are connected in series with the load therefore this inverter is called as **SERIES INVERTER**.
- The value of commutating components is selected such that the circuit becomes under damped.
- The anode current itself becomes zero in this inverter resulting the SCR turns off automatically therefore this inverter is also called as **SELF COMMUTATED OR LOAD COMMUTATED INVERTER**.

### Power Circuit Diagram

- The power circuit diagram of the series inverter is shown in the figure A. The SCR T1 and SCR T2 are turned on at regular interval in order to achieve desirable output voltage and output frequency.
- The SCR T2 is kept off at starting condition and polarity of voltage across capacitor is shown in the figure A.
- The operation of the series inverter is explained as follows.

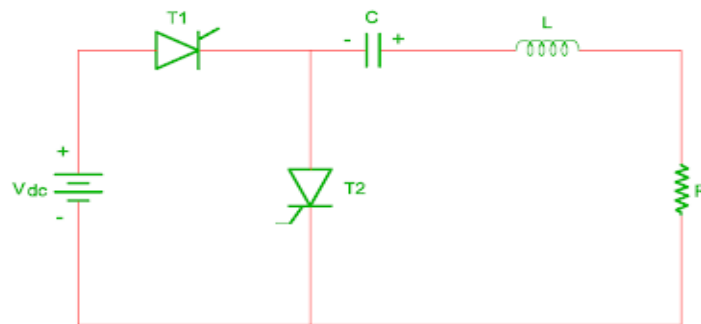


FIGURE A : BASIC SERIES INVERTER

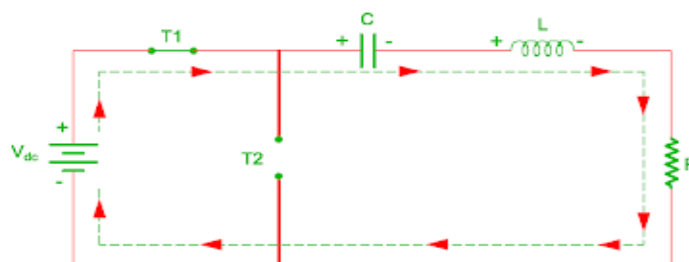


FIGURE B : EQUIVALENT CIRCUIT WHEN SCR T1 'ON'

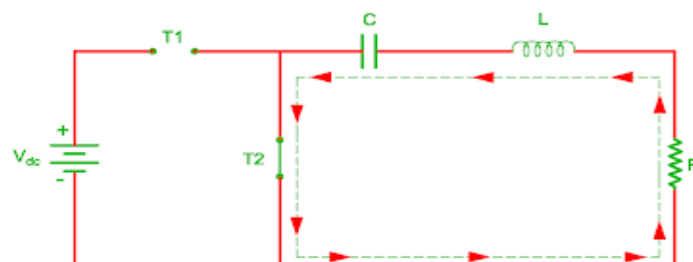


FIGURE C : EQUIVALENT CIRCUIT WHEN SCR T2 'ON'

## Operation

### Mode 1

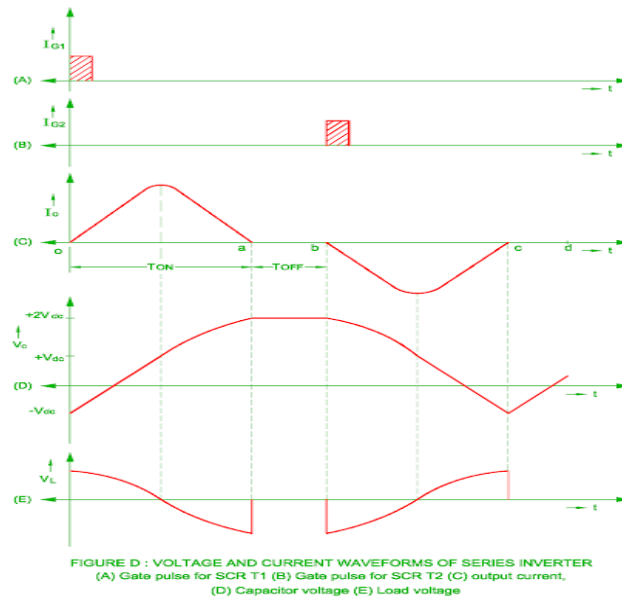
- The voltage  $V_{dc}$  directly applies to RLC series circuit as soon as the SCR T1 is turned on.
- The polarity of capacitor charging is shown in the figure B.
- The nature of the load current is alternating as there is under damped circuit of the commutating components.
- The voltage across capacitor becomes  $+V_{dc}$  when the load current becomes maximum.
- The voltage across capacitor becomes  $+2V_{dc}$  when the load current becomes zero at point a
- The SCR T1 automatically turns off at point a because the load current becomes zero.

### Mode 2

- The load current becomes zero from point a to b as the SCR T1 turns off in this time period.
- The SCR T1 and SCR T2 are turned off in this time duration and voltage across capacitor becomes equal to  $+2V_{dc}$ .

### Mode 3

- The SCR T2 is turned on at point b due to it receives positive capacitor voltage.
- The discharging of capacitor is done through SCR T2 and R – L circuit as shown in the figure.
- The load current becomes zero after it becomes maximum in the negative direction.
- The capacitor discharges from  $+2V_{dc}$  to  $-V_{dc}$  during this time and SCR T2 turns off automatically at point C due to load current becomes zero.
- The SCR T2 turns off during point C to D and SCR T1 again turns on. This way cycle repeat after it complete one turns.
- The positive AC output voltage half cycle generates due to DC voltage source whereas negative half cycle generates due to capacitor.
- There is always some time delay kept between one SCR turned on time and other SCR turned on time.
- The DC output gets short circuited due to continuous conduction of both SCRs if there is no time delay between SCRs.
- The time duration ab and cd must be greater than the SCR specific turn off time and it is called as **dead zone**.



### Limitations of Series Inverter

- The limitation of series inverter is as given below.
- The load current flows only during positive half cycle from supply source.
- The DC supply source gets short circuited if SCR T1 and SCR T2 simultaneously turned on.
- The rating of commutating components should high because the load current flows through it.
- The load voltage waveform gets distorted if the dead zone time or SCR turns on time high.
- The maximum output frequency of the inverter should be less than the ringing frequency.
- The DC supply source is short circuited if the output frequency of the inverter is higher than the ringing frequency.
- The maximum current during each high cycle and its time duration depends upon parameter of load this will result in poor regulation of the inverter output.

### Applications:

- This type of inverter generates sinusoidal waveform whose output frequency is in the range of 200 Hz to 100 kHz therefore it is applicable for
  - Induction heating
  - Sonar transmitter
  - Fluorescent lighting and
  - Ultrasonic generator

### Parallel Inverter:

- The power circuit diagram of the single phase parallel inverter is shown in the figure A.
- The commutating capacitor C is connected across supply source therefore it is called as **PARALLEL INVERTER**.
- The turns ratio of half primary winding and secondary winding is kept unity.
- The SCR T1 and SCR T2 are main SCRs from which load current passes through it.

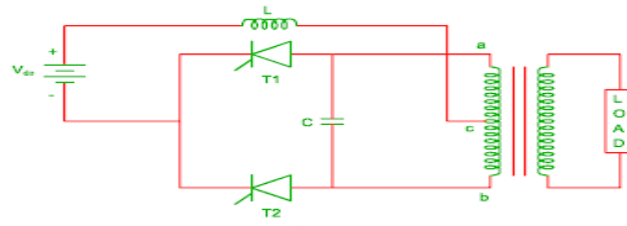


FIGURE A : PARALLEL INVERTER

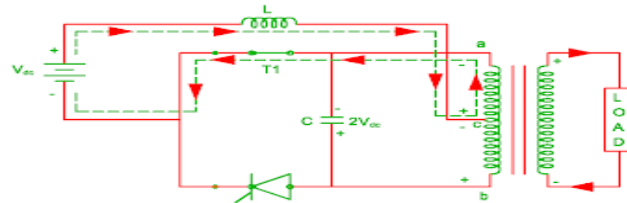


FIGURE B : EQUIVALENT CIRCUIT WHEN SCR T1 'ON'

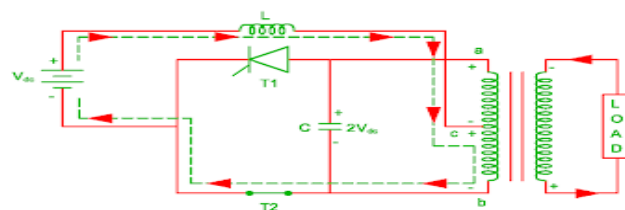


FIGURE C : EQUIVALENT CIRCUIT WHEN SCR T2 'ON'

### Mode 1

- The load current flows through path  $+V_{dc} - L - c - a - \text{SCR T1} - V_{dc}$  when the SCR T1 is turned on.
- This will generate flux and resulting emf in the transformer primary winding ac and bc.
- The charging of capacitor is done up to  $2V_{dc}$  voltage due to these induced emf.
- The polarity of capacitor C is done in the figure B.
- The maximum voltage withstand capability of the SCR T2 is  $2V_{dc}$ .
- The induced emf in the transformer secondary is  $2V_{dc}$  as there is unity turns ratio between half primary and secondary winding.
- This will result flow of current through load.

### Mode 2

- When the SCR T2 is turned on, the SCR T1 is turned off due to capacitor reverse voltage  $2V_{dc}$  applied across it.
- As the SCR T2 is turned on, the load current flows through path  $+V_{dc} - L - c - b - \text{SCR T2} - V_{dc}$  and discharging of capacitor is done through SCR T2.
- The charging of capacitor again done with  $-2V_{dc}$  voltage.
- The current flows during this interval are in reverse direction as that of when SCR T1 is turned on.
- The SCR T1 again turned on when it receives gate pulse and SCR T2 is in off condition during this interval.
- The waveform of the output voltage become rectangular due to alternately switching of SCR T1 and SCR T2.

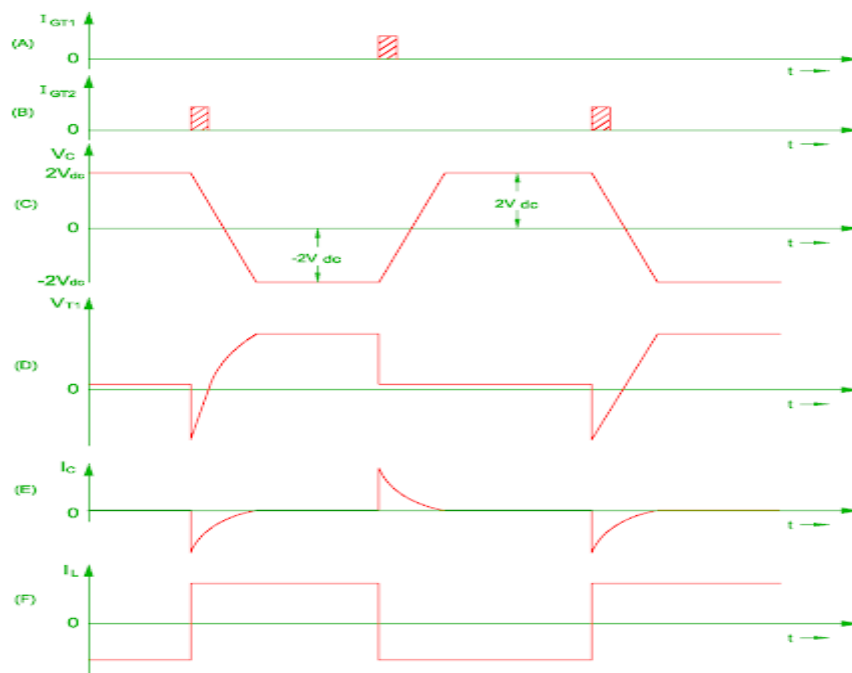


FIGURE D : VOLTAGE AND CURRENT WAVEFORMS FOR PARALLEL INVERTER  
 (A) GATE PULSE FOR SCR T1 (B) GATE PULSE FOR SCR T2 (C) VOLTAGE ACROSS CAPACITOR  
 (D) VOLTAGE ACROSS SCR T1 (E) CAPACITOR CURRENT (F) LOAD CURRENT

### Advantages

- Simple forced commutation circuit.
- Sinusoidal waveform at output is possible by using suitable filter circuit.

### Disadvantages

- The parallel inverter is useful only when load is fixed. (The output waveform changes due to change in load )
- The inverter does not useful for higher power for fixed value of inductor L and capacitor C.
- The design of inverter is done for fixed voltage.

### **Single Phase Half Bridge wave Inverter:**

- The power circuit diagram for the single phase half bridge inverter is shown in the figure A.
- The SCR triggering circuit and commutation circuit is not shown for simplicity.

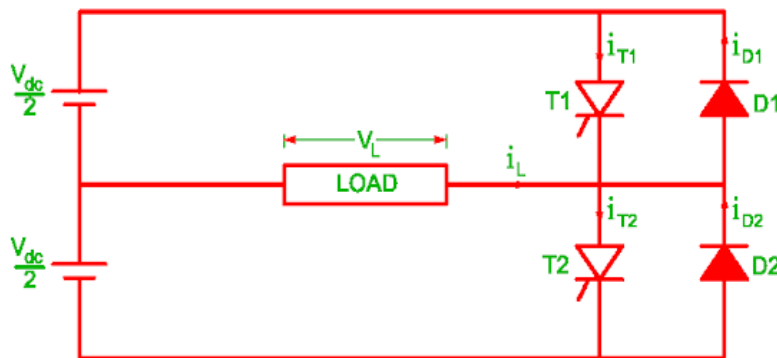


Figure A : SINGLE PHASE HALF BRIDGE INVERTER

- The SCR T1 is turned on for time  $0 \leq t \leq T/2$  times. This is shown in the figure C.
- The load receives  $V_{dc} / 2$  voltage from upper DC voltage source. The SCR T1 is turned off and SCR T2 is turned on at time  $t = T/2$ .
- The load receives  $-V_{dc} / 2$  voltage from lower half supply source during time  $T/2 \leq t \leq T$  time.
- Each SCR gate receives gate pulse at frequency  $f = 1/T$ .
- There is  $180^\circ$  phase displacement between two SCR gate signals.
- The frequency of the output voltage is equal to  $1/T$  and it is controlled by time period  $T$ .

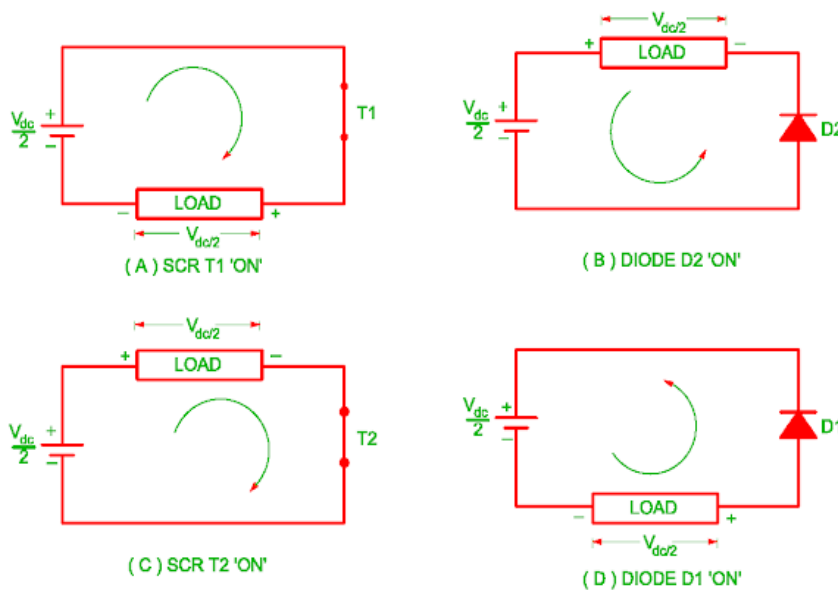


Figure B : OPERATION OF SINGLE PHASE HALF BRIDGE INVERTER

### Effect of type of Load on output waveform

- **Resistive load**
- The load voltage and load current waveform do not have any phase displacement when the resistive load is connected at the output.

## R – L load

- The working of the single phase half bridge inverter is explain as follows
- **Mode 1 (  $t_1 < t < t_2$  )**
- The load receives  $V_{dc} / 2$  voltage when the SCR T1 is turned on and load current increases slowly and exponentially.
- The load voltage and load current polarity becomes equal when SCR T1 is turned off. The energy stored in the load during this interval.

### Mode 2 ( $t_2 < t < t_3$ )

- The flow of inductive load current continues to flow when SCR T1 is turned off.
- The direction of load voltage reverses.
- The load current flows through conduction of lower half diode D2. The stored energy of load feedback to lower half.

### Mode 3 ( $t_3 < t < t_4$ )

- The load current becomes zero and SCR T2 is turned on during this interval.
- The voltage across load becomes  $-V_{dc} / 2$ .
- The load current becomes maximum negative at the end of this period (  $t_4$  time ).

### Mode 4 ( $t_4 < t < t_5$ )

- The SCR T2 is turned off at time  $t_4$  but the load current continues to flow due to inductive load.
- The voltage across load becomes equal to  $+V_{dc} / 2$ .
- The load current flows through upper half portion due to conduction of diode D1.
- The energy stored of load feedback to upper part of the supply source.
- The power flows from supply to load and vice versa.
- The main disadvantage of the single phase half bridge inverter is that it requires three wire DC supplies.

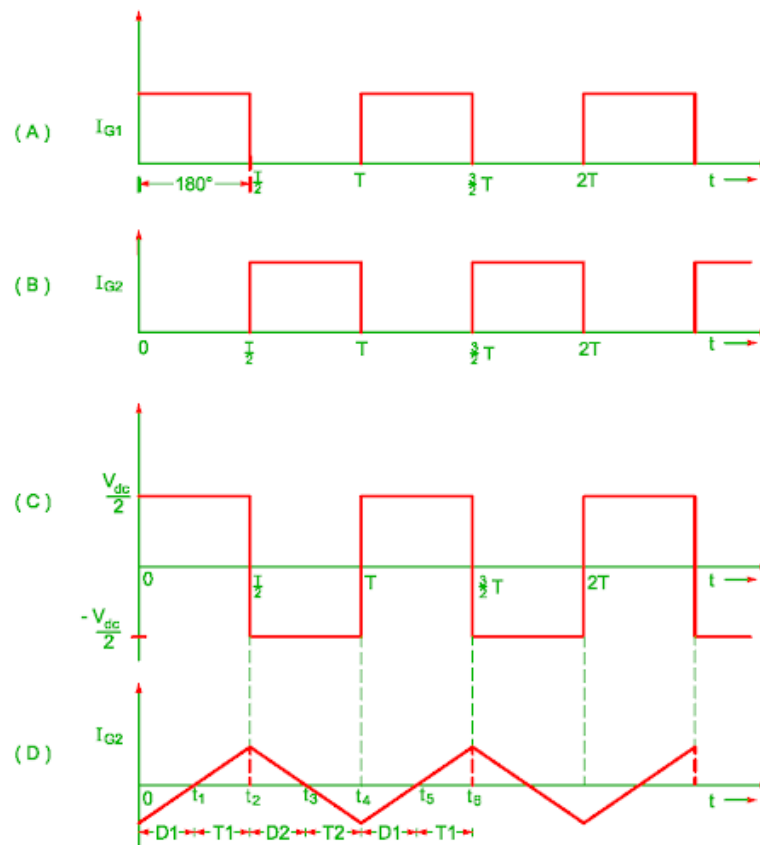


Figure C : GATE SIGNAL AND OUTPUT VOLTAGE WAVEFORMS  
 ( A ) GATE SIGNAL FOR SCR T1  
 ( B ) GATE SIGNAL FOR SCR T2  
 ( C ) OUTPUT VOLTAGE  
 ( D ) OUTPUT CURRENT FOR R-L LOAD

### Single Phase Full Bridge Inverter

- The power circuit diagram for the single phase full bridge inverter is shown in the figure A.
- The SCR triggering circuit and commutation circuit is not shown for simplicity.
- There are two wire DC supply source, four freewheeling diodes and four SCRs used in this inverter.
- The SCR T1 and SCR T2 are turned on at same time whose frequency is  $f = 1/T$ . Similarly the SCR T3 and SCR T4 are turned on simultaneously.
- There is  $180^\circ$  phase difference between positive group of SCRs ( SCR T1 and SCR T2 ) and negative group of SCRs ( SCR T3 and SCRT4 ).



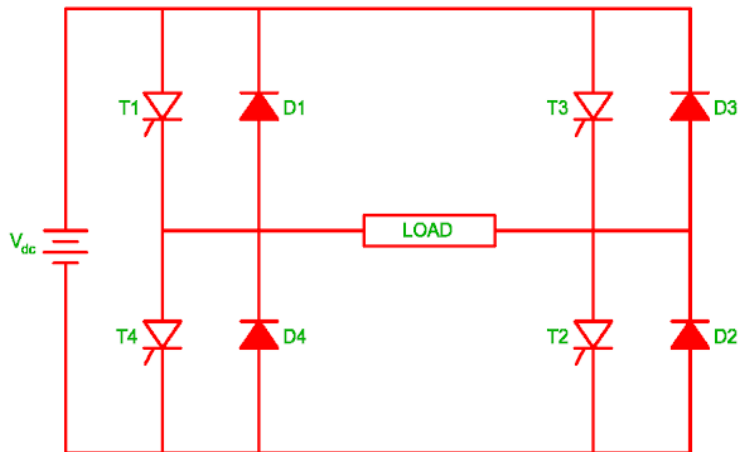


FIGURE A : SINGLE PHASE FULL BRIDGE INVERTER

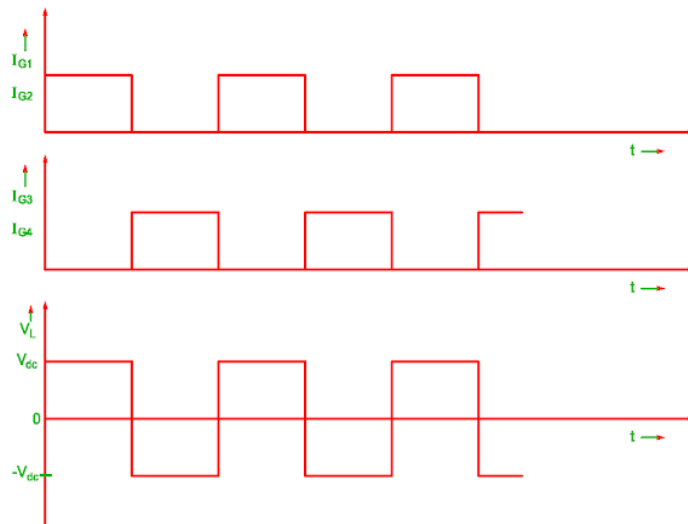


FIGURE B : GATE SIGNALS AND OUTPUT VOLTAGE WAVEFORMS

The working of single phase full bridge inverter is explain as follows

#### Mode 1

- The load voltage becomes to  $+V_{dc}$  when SCR T1 and SCR T2 are turned on at same time.
- Therefore the load current flows through path  $(+)V_{dc} - \text{SCR T1} - \text{load} - \text{SCR T2} - V_{dc}(-)$ .
- The load current and load voltage becomes positive during this period therefore the power flows from supply to load.

#### Mode 2

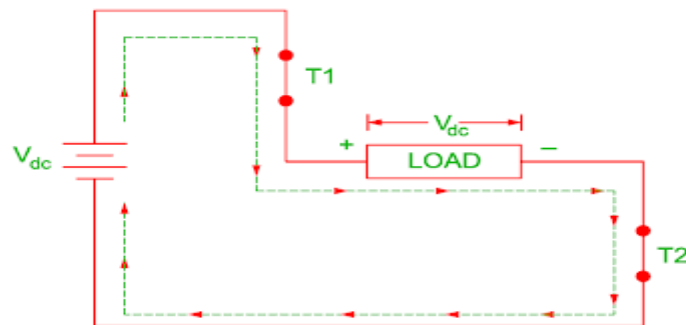
- The polarity of voltage across load changes due to inductive load and as soon as the SCR T1 and SCR T2 are turned off in this mode.
- As the diode D3 and D4 conduct, the load current flows through path diode D3 –  $(+)V_{dc} - V_{dc}(-) - \text{diode D4}$ .
- The power flows from load to supply during this mode.

### Mode 3

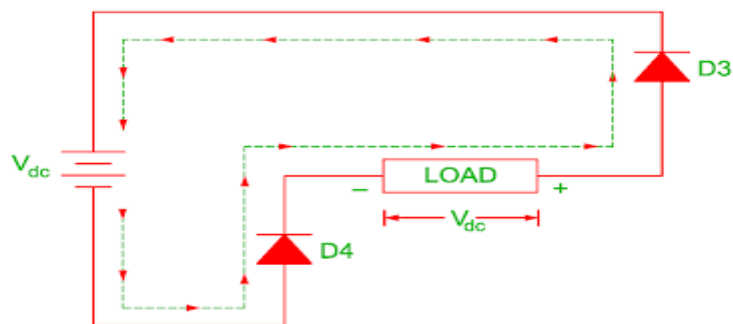
- The SCR T1 and SCR T2 are turned off whereas SCR T3 and SCR T4 are turned on during this mode.
- The voltage across load becomes  $-V_{dc}$  and current flows through path  $(+)V_{dc} - \text{SCR T3} - \text{load} - \text{SCR T4} - V_{dc}(-)$ .
- The power flows through supply to load as the load voltage and load current both are negative during this period.

### Mode 4

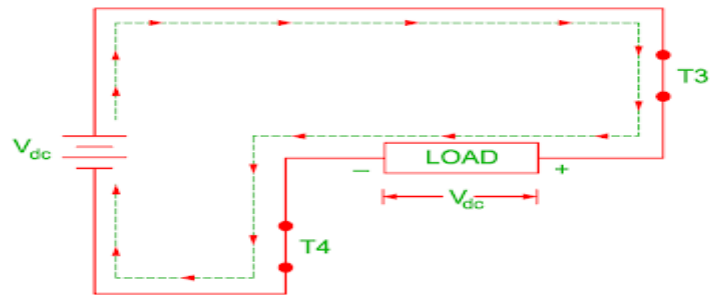
- The polarity of voltage across load changes as the SCR T3 and SCR T4 are turned off in this mode.
- The load current flows through path diode D1  $(+)V_{dc} - V_{dc}(-) - \text{diode D2} - \text{load}$  due to conduction of freewheeling diode D1 and D2.
- The power flows from load to supply as the direction of load current reverses during this mode.
- The output voltage of the single phase full bridge inverter is double to that of single phase half bridge inverter.



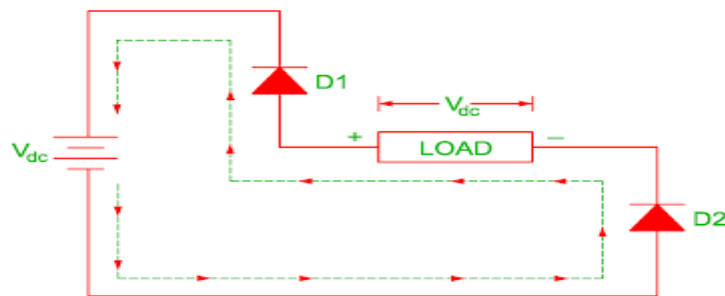
( A ) SCR T1 AND T2 'ON'



( B ) SCR T1 AND SCR T2 'OFF'  
DIODE D3 AND D4 'ON'



( C ) SCR T3 AND T4 'ON'



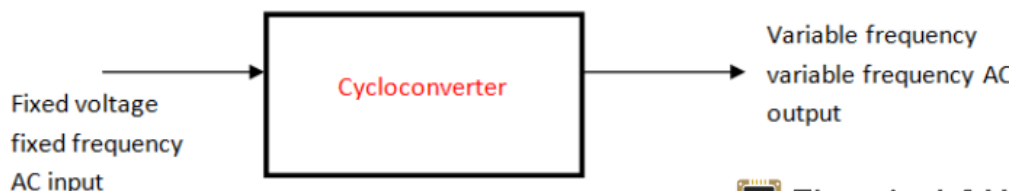
( D ) SCR T3 AND SCR T4 'OFF'  
DIODE D1 AND D2 'ON'

FIGURE C : OPERATION OF SINGLE PHASE FULL BRIDGE INVERTER

## Cycloconverter:

A **cycloconverter** (also known as a cycloinverter or CCV) converts a constant voltage, constant frequency AC waveform to another AC waveform of a different frequency. A cycloconverter achieves this through synthesizing the output waveform from segments of the AC supply (without an intermediate DC link).

The main forms of electrical energy commonly available are constant DC (Direct Current) and constant AC (Alternating Current). Often though, we need to swap between AC and DC, change the frequency, or swap from constant to variable power. For these conversion purposes, several converters like inverters, rectifiers, DC choppers and **cycloconverters** are employed. The cycloconverters can in fact transfer AC power of a fixed frequency to the AC power of a different frequency (see figure).



### Principle of operation

- The cyclo converter is made of two converters in which one converter works as a positive converter and second converter works as negative converter.
- The firing angle of both converters are set such that

$$\alpha_p + \alpha_N = \pi$$

Where

$\alpha_p$  = Firing angle of positive converter and

$\alpha_N$  = Firing angle of negative converter

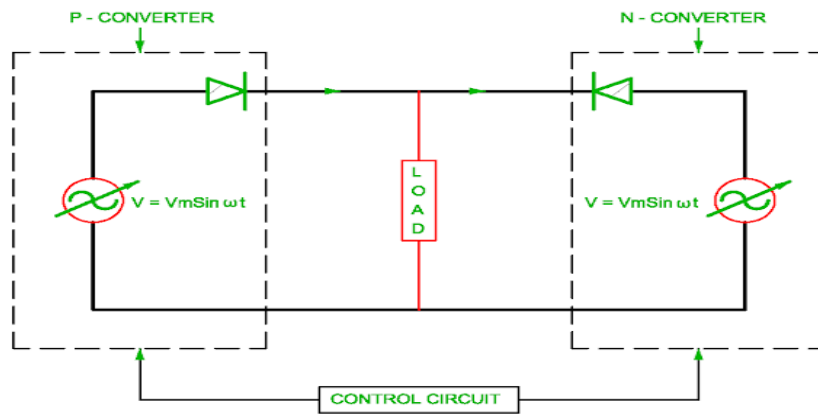


FIG A : EQUIVALENT CIRCUIT OF THE CYCLECONVERTER

- The firing angle of both converters is set such that it will change the output frequency.
- The P – converter and N – converter is made by series connection of variable alternating supply and diode.
- The output voltage of the both converter becomes equal in the P – type converter and N – type converter of the ideal cyclo converter.
- The output voltage at the terminal of the cyclo converter is either of the alternating voltage of the converter because each converter has equal alternating voltage amplitude, phase as well as frequency.
- The power flows from either load to converter to converter to load by controlling the firing angle of the each converter.
- The unidirectional property of the P – converter and N – converter results in P – converter works in positive half cycle of alternating supply and N – converter works in negative half cycle of alternating supply.
- It does not depend upon phase between load voltage and load current.

### Types of Cyclo Converter

There are following types of cyclo converter

#### According to Output frequency

##### Step up Cyclo converter

- It is a cyclo converter in which output frequency is greater than the input frequency of the input supply.

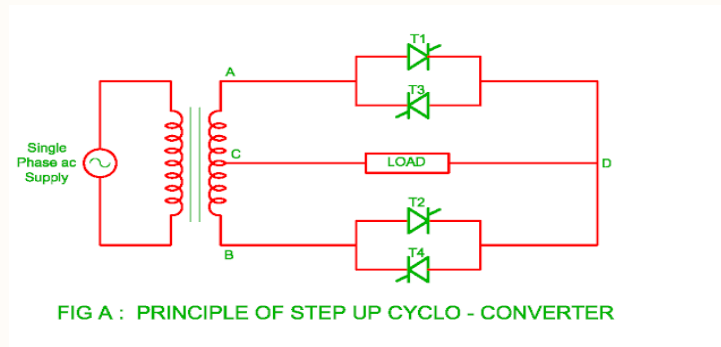
##### Step down Cyclo converter

- It is a cyclo converter in which output frequency is less than the input frequency of the input supply.

##### Step up Cycloconverter

- It is only cyclo converter in which commutation of SCRs is done by forced commutation.
- The power circuit of the step up cyclo converter is shown in the figure A. There are two group of SCRs in which one group ( SCR T1 and SCR T2 ) generates positive half cycle and other group ( SCR T3 and SCR T4 ) generates negative half cycle.

- The output frequency of the cyclo converter is greater than the input frequency therefore it is called as step up cycloconverter.



### Operation

- The operation of the cyclo converter is explained as below.

#### **Positive half cycle**

- The SCR T1 is turned on during positive half cycle of the alternating supply during time 0 to  $t_1$  therefore the load current flows through path A – SCR T1 – D – LOAD – C.
- The output voltage becomes positive. The SCR T1 is turned off by forced commutation at time  $t_1$  and SCR T4 is turned on.
- The load current flows through path C – LOAD – D – SCR T4 – B.
- The output voltage becomes negative during this time.

#### **Negative half cycle**

- The SCR T2 is turned on during negative half cycle ( at  $\pi$  time ) of alternating cycle therefore the load current flows through path B – SCR T2 – D – LOAD – C .
- The output voltage becomes positive. The SCR T4 is turned off at time  $t_4$  by forced commutation and SCR T2 is turned on.
- The output voltage becomes negative during this time interval.
- The SCR T3 is turned off at time  $t_5$  by forced commutation and SCR T2 is again turned on.
- This will result in output voltage becomes positive. The cycle completes in this way. The output frequency ( from figure B )

$$f_0 = 1 / ( t_2 - t_1 ) \text{ Hz}$$

The output frequency of the cyclo converter  $f_0$  is always greater than the supply or input frequency.

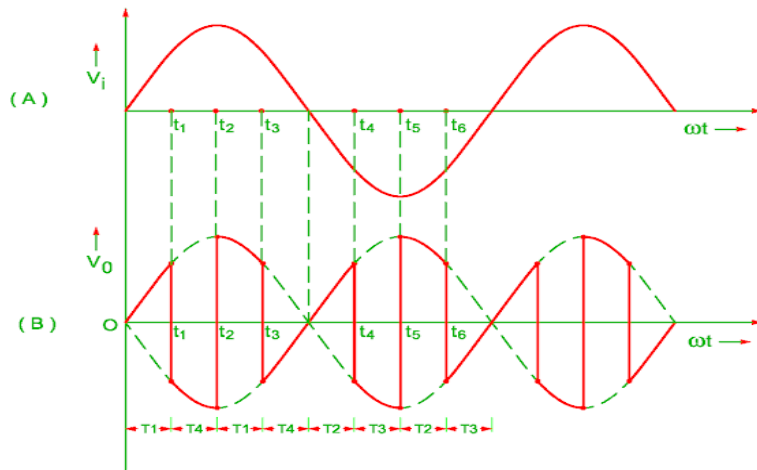


FIG B : WAVEFORMS OF STEP - UP CYCLO - CONVERTER  
 ( A ) INPUT VOLTAGE  
 ( B ) OUTPUT VOLTAGE

## Advantages, Disadvantages and Application of the Cycloconverter

### Advantages

- The cyclo converter is a single stage converter therefore its efficiency is very high.
- The cyclo converter operates on line commutation ( except step up cyclo converter ) therefore extra force commutation components are not required.
- The power transfer in the cyclo converter is possible from supply to load and vice versa at any power factor.
- If one of the **SCR** fails, the cyclo converter operates with distorted output.
- The cyclo converter generates high quality sinusoidal waveform for low output frequency whereas the static inverter generates square waveform for low output frequency ( < 10 Hz ).

### Disadvantages

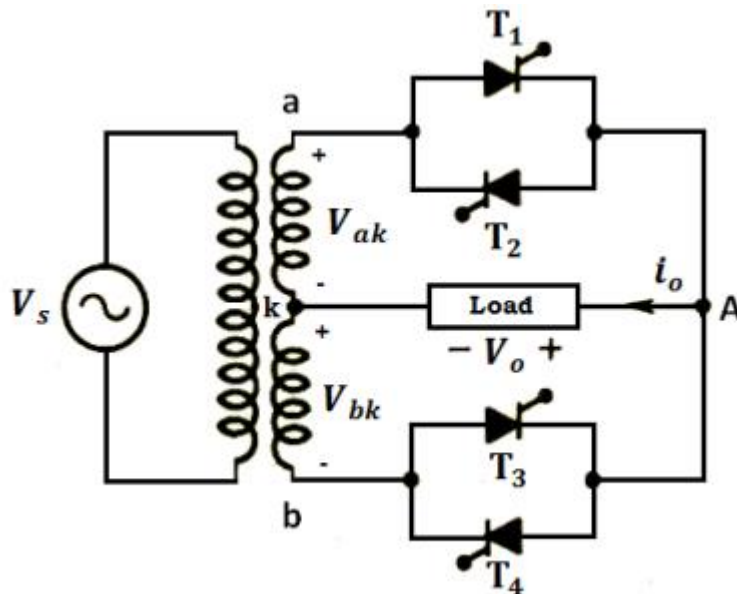
- The control circuit becomes complex because there are large numbers of **SCRs** in the cyclo converter.
- The power factor of the cyclo converter becomes low for low output voltage.
- The supply gets short circuited due to failure of commutation circuit.
- The output frequency of the cyclo converter is 1/3th or 1/2 for reasonable power output and efficiency.

### Application

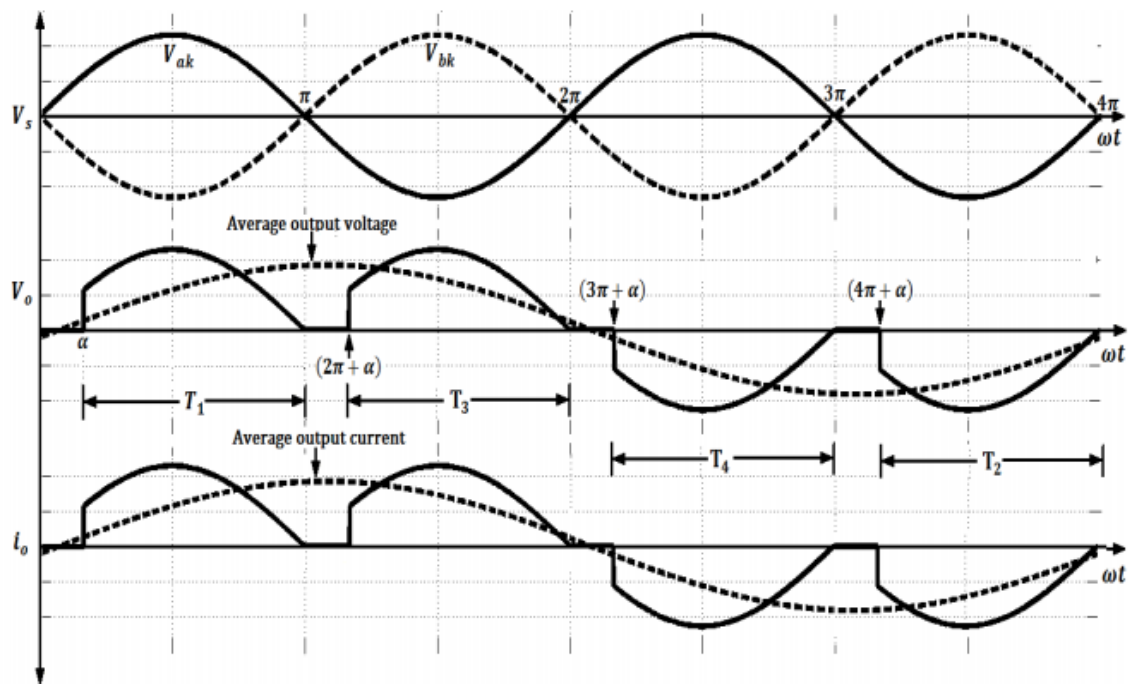
- Variable frequency supply for air craft or shipyard
- Speed control of AC drive
- Induction heating

## Step-Down Cycloconverter:

Step-down cycloconverter is a device which steps down the fixed frequency power supply input into some lower frequency. It is a frequency changer. If  $f_s$  &  $f_o$  are the supply and output frequency, then  $f_o < f_s$  for this cycloconverter.



- When "a" is positive with respect to "k" in figure 5 during positive half cycle of supply voltage forward biased thyristor  $T_1$  is triggered at  $\omega t = \alpha$ .
- With this, load current  $i_o$  starts flowing in the positive direction from "A" to "k". Load current  $i_o$  is shown in figure 6.
- Thyristor  $T_1$  remains on till  $\omega t = \pi$ . At  $\omega t = \pi$  the load current is zero as supply voltage falls to zero and hence  $T_1$  is commutated at  $\pi$ .
- After  $\pi$ , negative cycle of supply starts hence "b" is positive with respect to "k" thereby forward biasing thyristor  $T_2$ .  $T_2$  is triggered at  $\omega t = \pi + \alpha$ . Load voltage now follows  $V_{bk}$  as shown in figure 6. At  $\omega t = 2\pi$  thyristor  $T_2$  is commutated.
- After such two positive half cycles of load voltage and load current, thyristor  $T_4$  is gated at  $(3\pi + \alpha)$  when "k" is positive with respect to "b". As  $T_4$  is forward biased, it starts conducting but load direction is reversed, i.e. it is now from "k" to "A".
- At  $\omega t = 4\pi$ , thyristor  $T_4$  is naturally commutated and load current goes to zero as shown in figure 6.
- In a sequence at  $\omega t = 4\pi + \alpha$ ,  $T_2$  is triggered as "k" is positive with respect to "a"  $T_2$  starts conducting and load voltage and current will be negative as shown in figure 6.
- In this manner, two negative half cycles of load voltage and current, equal to the two positive half cycle, are generated as shown in figure 6.
- It is seen from the figure 6 that frequency of output voltage and current is  $f_o = \frac{1}{2}f_s$



(Wave form of step-down cycloconverter with R-load)

## Applications:

Cycloconverters have a large set of industrial application, the following are the few

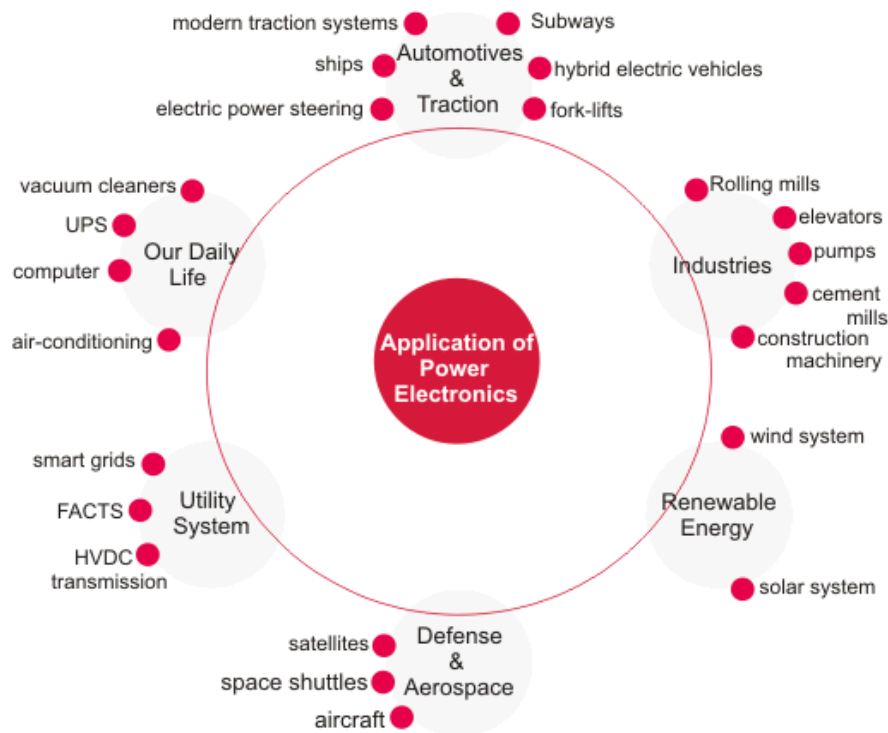
- Grinding Mills
- Heavy Washing Machines
- Mine Winders
- HVDC Power lines
- Aircraft Power supply
- SVG (Static VAR Generators)
- Ship Propulsion system

## CHAPTER-4

### UNDERSTAND APPLICATIONS OF POWER ELECTRONIC CIRCUITS

List applications of power electronic circuits:





- Our Daily Life: If we look around ourselves, we can find a whole lot of power electronics applications such as a fan regulator, light dimmer, air-conditioning, induction cooking, emergency lights, personal computers, vacuum cleaners, UPS (uninterrupted power system), battery charges, etc.
- Automotives and Traction: Subways, hybrid electric vehicles, trolley, fork-lifts, and many more. A modern car itself has so many components where power electronic is used such as ignition switch, windshield wiper control, adaptive front lighting, interior lighting, **electric power** steering and so on. Besides power electronics are extensively used in modern traction systems and ships.
- Industries: Almost all the motors employed in the industries are controlled by power electronic drives, for eg. Rolling mills, textile mills, cement mills, compressors, pumps, fans, blowers, elevators, rotary kilns etc. Other applications include welding, **arc furnace**, cranes, heating applications, emergency power systems, construction machinery, excavators etc.
- Defense and Aerospace: Power supplies in aircraft, satellites, space shuttles, advance control in missiles, unmanned vehicles and other defense equipments.
- Renewable Energy: Generation systems such as solar, wind etc. needs power conditioning systems, storage systems and conversion systems in order to become usable. For example **solar cells** generate DC power and for general application we need AC power and hence power electronic converter is used.
- Utility System: **HVDC transmission**, VAR compensation (SVC), static circuit breakers, generator excitation systems, **FACTS**, smart grids, etc.

## Factors Affecting The Speed Of Dc Motor

The operation of a DC motor is typically designed such that when a current carrying conductor is placed within a magnetic field, there is bound to be the mechanical force that goes through the

**conductors.** A permanent magnetic DC motor, however, does not have field circuit. It has just the armature circuit. This differentiates it from other DC motors.

**The factors affecting DC control are therefore:**

- The applied voltage
- The flux
- The voltage across an armature

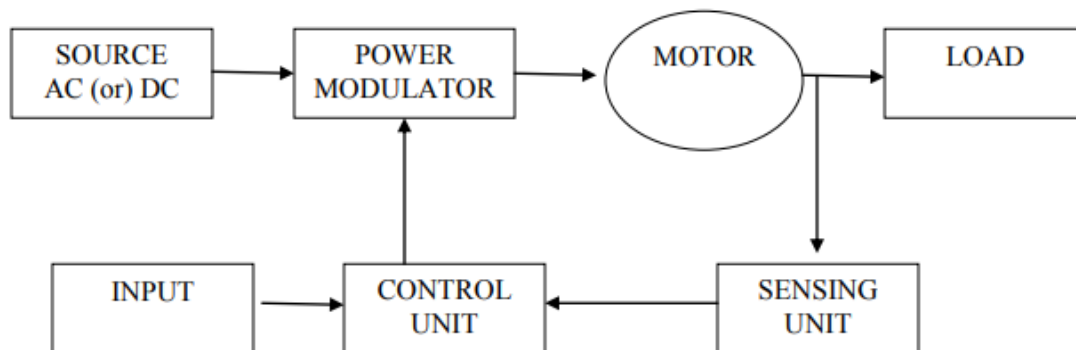
**Considering these factors, speed control can then be achieved through the following techniques:**

- Flux control method: This is done by varying the current via the field winding, thus altering the flux.
- Rheostatic control: changing the armature route resistance which also changes the applied voltage across the armature.
- Voltage method: changing the applied voltage

### Electric drive:

An Electric Drive can be defined as an electromechanical device for converting electrical energy to mechanical energy to impart motion to different machines and mechanisms for various kinds of process control.

**BLOCK DIAGRAM OF AN ELECTRICAL DRIVES** The basic block diagram for electrical drives used for the motion control is shown in the following figure1.1



**Fig 1.1 Block Diagram for Electrical Drives**

The aggregate of the electric motor, the energy transmitting shaft and the control equipment by which the motor characteristics are adjusted and their operating conditions with respect to mechanical load varied to suit practical requirements is called as electric drive.

Drive system=Drive + load

### Separately Excited and Shunt DC Motors

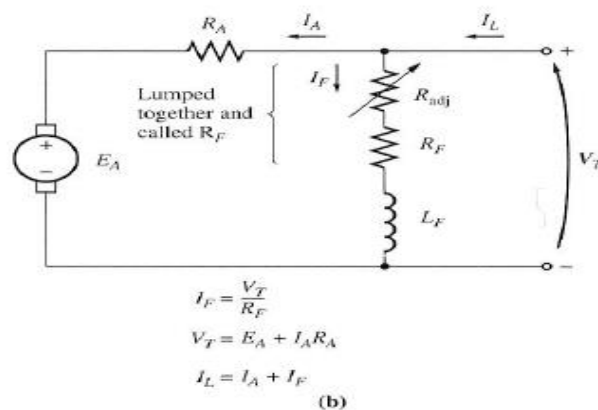
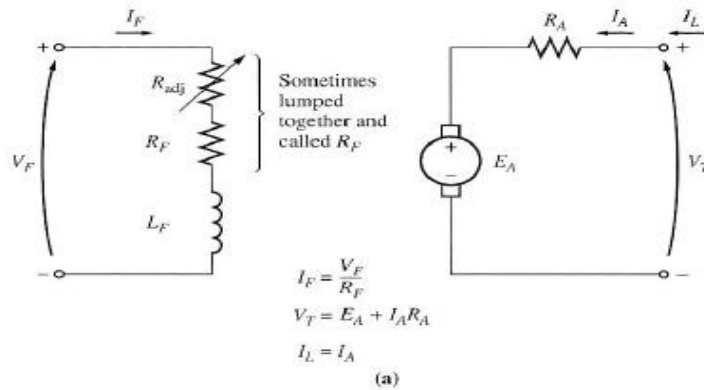
A separately excited dc motor is a motor whose field circuit is supplied from a separate constant-voltage power supply, while a shunt dc motor is a motor whose field circuit gets its power directly across the armature terminals of the motor.

When the supply voltage to a motor is assumed constant, there is no practical difference in behaviour between these two machines. Unless otherwise specified, whenever the behaviour of a shunt motor is described, the separately excited motor is included too.

The equivalent circuits of these two DC motors are shown in Fig.8.6

The KVL equation for the armature circuit is:

$$V_T = E_A + I_A R_A$$



The internal generated voltage (back emf) is given by:

$$E_A = K_e \phi n$$

Where  $n$  = speed of the motor in revolution per minute (rpm),

$\Phi$  = flux per pole in Weber (Wb),

$$K_e = \text{Machine constant} = \frac{p \cdot Z}{60a}$$

$p$  = number of poles,  $Z$  = total number of conductors,  $a$  = number of parallel paths ( $a = p$  for lap winding,  $a = 2$  for wave winding).

and the developed motor torque is

$$T_d = K_T I_A \phi$$

$K_T$  = Torque constant =  $9.55 K_e$ ,  $I_A$  = armature current (A).

### The speed equation and the terminal characteristics of a DC Motor

A terminal characteristic of a dc machine is a plot of its output torque versus speed.

The output characteristic of a separately excited and shunt dc motors are approximately the same and can be derived from the induced voltage and torque equations of the motor plus the KVL as follows:

$$\text{KVL } V_T = E_A + I_A R_A$$

The induced voltage  $E_A = K_e \phi n$

$$V_T = K_e \phi n + I_A R_A$$

Since  $T_d = K_T I_A \phi$

current  $I_A$  can be expressed as:  $I_A = \frac{T_d}{\phi K_T}$

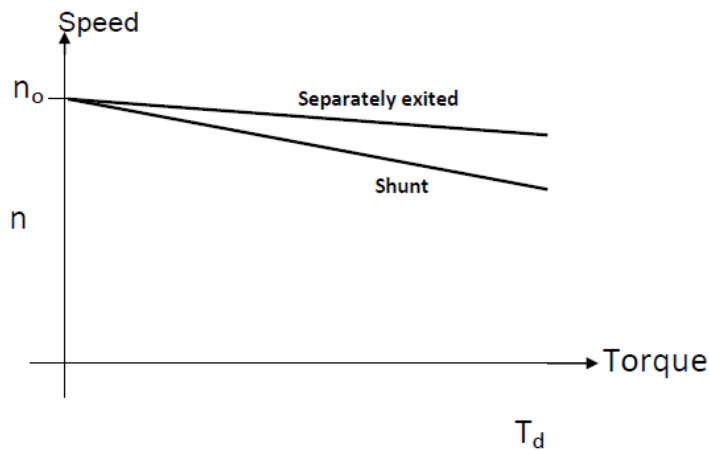
Combining the  $V_T$  and  $I_A$  equations:

$$V_T = K_e \phi n + \frac{T_d}{K_T \phi} R_A$$

$$n = \frac{V_T}{K_e \phi} - \frac{R_A}{K_T K_e \phi^2} T_d$$

Where  $n$  = speed in rpm.

This equation is called the dc motor speed equation and is just a straight line with a negative slope. The resulting torque-speed characteristic of a shunt dc motor is shown in fig.



Speed-torque characteristics of dc shunt motor

Where :  $n_0$  = no load speed (i.e. when  $T_d = 0$ ) or

$$n_0 = \frac{V_T}{K_e \phi}$$

### Speed Control of Shunt and separately excited DC Motors

Two common methods

- i - Adjusting the field resistance  $R_F$  (and thus the field flux  $\phi$ )
- ii Adjusting the terminal voltage applied to the armature.

Less common method:

- iii-Inserting a resistor in series with the armature circuit.

### Solid state Speed Control of DC Motor:

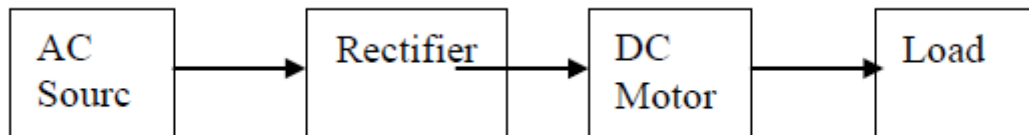
The DC Motor speed can be controlled through power semiconductor switches. The power semiconductor switches are SCR, MOSFET, IGBT etc., this type of speed control is called static ward leonard Drive.

types of DC Drives:

- Phase controlled rectifier fed DC drives
- Single phase rectifier fed DC drives
- Three phase rectifier fed DC drives

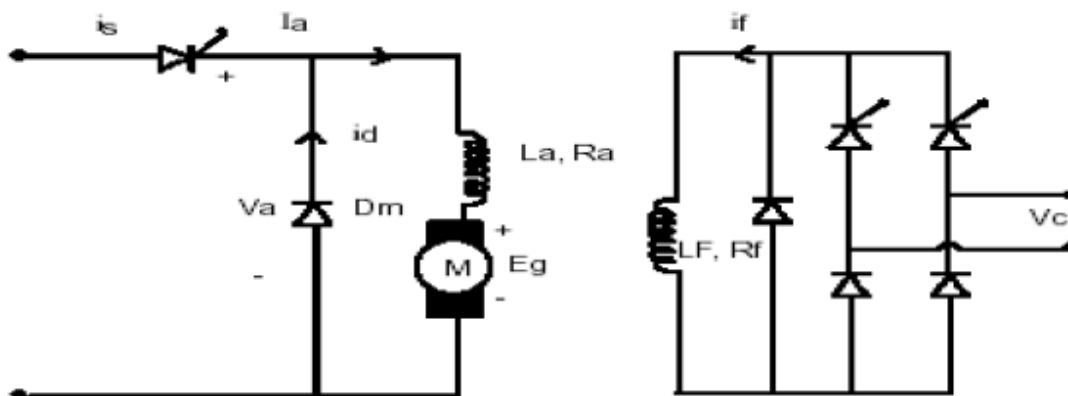
- One quadrant converter
- Two quadrant converter
- Four quadrant converter
- Chopper fed DC drives
- One quadrant Chopper drives
- Two quadrant Chopper drives
- Four quadrant Chopper drives

#### Single phase Controlled rectifier fed DC drives:



#### Half wave controlled rectifiers

- In the single phase half controlled rectifier, the load resistor,  $R_L$  is connected in series with anode A.
- A variable resistance  $r$  is inserted in the gate circuit for controlling gate current. During the negative half cycles of the input ac voltage .
- The SCR does not conduct regardless of the gate voltage, because anode is negative with respect to cathode K.
- The SCR will conduct during the positive half cycles provided appropriate gate current is made to flow .the gate current can be varied with the help of variable resistance  $r$  inserted in the gate circuit for this purpose .the greater the gate current, the lesser will be the supply voltage at which SCR will start conducting.



- Assume that the gate current is such that SCR starts conducting at a positive voltage  $V$ , being less than peak value of input ac voltage  $V_{max}$ , it is clear that the SCR starts conducting, as soon as input ac voltage becomes equal to  $V$  volts in the positive half cycle, and will continue conducting till ac voltage becomes zero when it will turn-off, again in next positive half cycle, SCR will start conducting when input ac voltage becomes equal to  $V$  volts.
- The angle by which the SCR starts conducting is called as firing angle or delay angle  $\omega t$  the conduction will take place for radians.
- The thyristor circuit uses phase commutation.
- The average output voltage ( $V_L$ ) from a half-wave controlled rectifier for the given input ac voltage  $V = V_{max} \sin \omega t$

$$V_L = \frac{V_{\max}}{\pi} \cos^2 \frac{\alpha}{2}$$

$$I_L = \frac{V_L}{R_L} = \frac{V_{\max}}{\pi R_L} \cos^2 \frac{\alpha}{2}$$

Thus the desired value of load current  $I_L$  can be obtained by varying firing angle  $\alpha$

$$I_L = \frac{V_{\max}}{\pi R_L} \text{ when } \alpha = 0$$

$$I_L = \frac{V_{\max}}{2\pi R_L} \text{ when } \alpha = \frac{\pi}{2}$$

Hence, load current decreases with the increase in value of firing angle. So the terminal voltage decreases the motor run slowly and vice versa.

#### With Freewheeling diode

- Let RL load is connected with the single-phase half controlled rectifier .Due to the inductive nature of the load, the load current lags by an angle with respect to the voltage.
- During voltage reversal, the voltage reaches zero but due to the inductive nature of the load, the current still flow through the thyristor.
- it takes some time for the current to reach zero. so during that instant ,a negative voltage will be appearing across the inductive load and the freewheeling diode connected in parallel with the load is turned on, as the diode is turned on, the load voltage becomes the diode forward drop.
- It is otherwise called commutating diode. This diode is connected anti parallel with load .this diode comes into picture only when the load is inductive.
- In case of inductive load even though the input voltage reaches zero and becomes negative, the current is still flowing through the thyristor, so it remains on when the voltage across the load becomes negative.
- The freewheeling diode is turned on when the load voltage is negative.
- So, the voltage across the load becomes zero and it provides a path for the load current. During this interval, the energy stored in the inductor is dissipated through this diode
- This freewheeling diode prevents the negative the negative reversal of voltage across the load.
- It improves the input power factor.
- It improves the load current wave from thereby it improves the performance parameters.

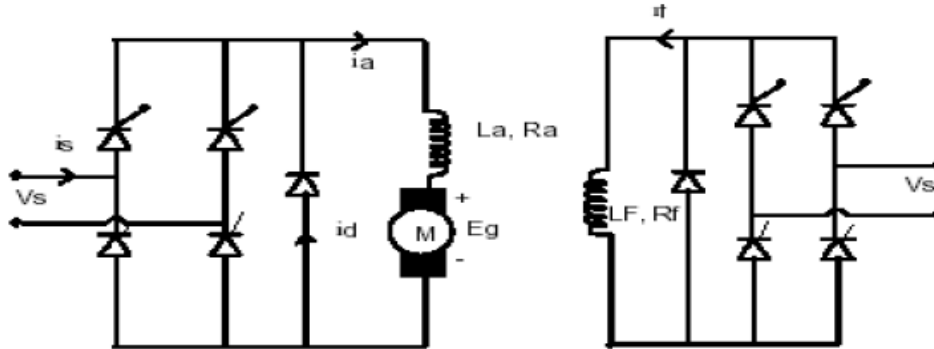
#### 4.6.1.2 Full controlled rectifier

- The full wave half controlled rectifier circuit consists of two thyristors and two diodes.
- The gates of both thyristors are supplied from two gate control supply circuits.
- One thyristors (or SCR) conducts during the positive half cycles and the other during the negative half cycles and thus unidirectional current flows through the load circuit.
- Now, if the supply voltage  $v = V_{\max} \sin \omega t$  and firing angle is  $\alpha$ , then average output voltage is given by

$$V_L = \frac{1}{\Pi} \int_{\alpha}^{\Pi} V_{\max} \sin \omega t d(\omega t)$$

$$V_L = \frac{V_{\max}}{\Pi} (1 + \cos \alpha)$$

$$= \frac{2V_{\max}}{\Pi} \cos^2 \frac{\alpha}{2}$$



Average output current,

$$I_L = \frac{V_L}{R_L} = \frac{2V_{\max}}{\Pi R_L} \cos^2 \frac{\alpha}{2}$$

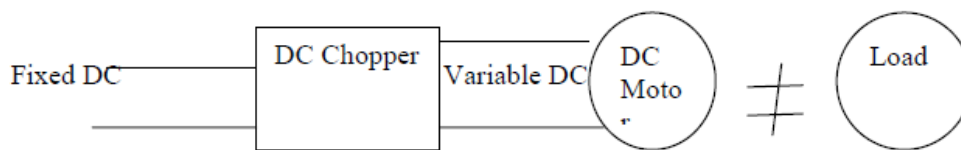
#### Advantages:

- Basic operation is simple and reliable
- Time response is faster
- Small size
- Less weight

#### Disadvantages:

- Introduce current and voltage harmonics into supply systems
- The overload capacity is lower
- Due to switching of SCR distortion of the AC supply voltage and telephone interference may be produced.

#### Chopper Fed DC Drives:



✓ Fixed DC voltage is fed to the DC chopper circuit.

DC chopper converts fixed DC into variable DC voltage.

- This variable DC Voltage is fed to the motor.
- By varying the DC voltage, the motor speed can be controlled.
- Self commutated devices such as MOSFET's, Power transistors, IGBT's and IGCT's are used for building choppers because they can be commutated by a low power control signal and do not need commutation circuit and can be operated at a higher frequency for the same rating.

#### Advantages:

- High efficiency
- Light weight
- Flexibility in controls
- Small size



- Quick response

**Applications:**

- Battery operated vehicles
- Traction motors
- Hoists
- Electric braking
- Trolley cars

**Chopper drives:**

When variable dc voltage is to be obtained from fixed dc voltage, dc chopper is the ideal choice. Use of chopper in traction systems is now accepted all over the world. A chopper is inserted in between a fixed voltage dc source and the dc motor armature for its speed control below base speed. In addition, chopper is easily adaptable for regenerative braking of dc motors and thus kinetic energy of the drive can be returned to the dc source. This results in overall energy saving which is the most welcome feature in transportation systems requiring frequent stops, as for example in rapid transit systems. Chopper drives are also used in battery-operated vehicles where energy saving is of prime importance.

Though choppers can be used for dynamic braking and for combined regenerative and dynamic control of dc drives, only the following two control modes are described in what follows.

1. Power control or motoring control.
2. Regenerative-braking control.

Both the chopper control methods are now described. In addition, two-quadrant and four-quadrant chopper drives are also described.

**12.5.1. Power Control or Motoring Control**

Fig. 12.20 (a) shows the basic arrangement of a dc chopper feeding power to a dc series motor. The chopper is shown to consist of a force-commutated thyristor, it could equally well be a transistor switch. It offers one-quadrant drive, Fig. 12.20 (b). Armature current is assumed continuous and ripple free. The waveforms for the source voltage  $V_s$ , armature terminal voltage  $v_t = v_0$ , armature current  $i_a$ , dc source current  $i_s$  and freewheeling-diode current  $i_{fd}$  are sketched in Fig. 12.20 (c). From these waveforms, the following relations can be obtained :

$$\text{Average motor voltage, } V_0 = V_t = \frac{T_{on}}{T} \cdot V_s = \alpha V_s = f T_{on} \cdot V_s \quad \dots(12.32)$$

where  $\alpha = \text{duty cycle} = \frac{T_{on}}{T}$

and  $f = \text{chopping frequency} = \frac{1}{T}$

$$\begin{aligned} \text{Power delivered to motor} &= (\text{Average motor voltage}) (\text{average motor current}) \\ &= V_t \cdot I_a = \alpha \cdot V_s \cdot I_a \end{aligned}$$

$$\text{Average source current} = \frac{T_{on}}{T} \cdot I_a = \alpha \cdot I_a$$

$$\begin{aligned} \text{Input power to chopper} &= (\text{average input voltage}) (\text{average source current}) \\ &= V_s \cdot \alpha I_a \end{aligned}$$

For the motor armature circuit,

$$V_s = \alpha V_s = E_a + I_a (r_a + r_s) = K_m \cdot \omega_m + I_a (r_a + r_s)$$



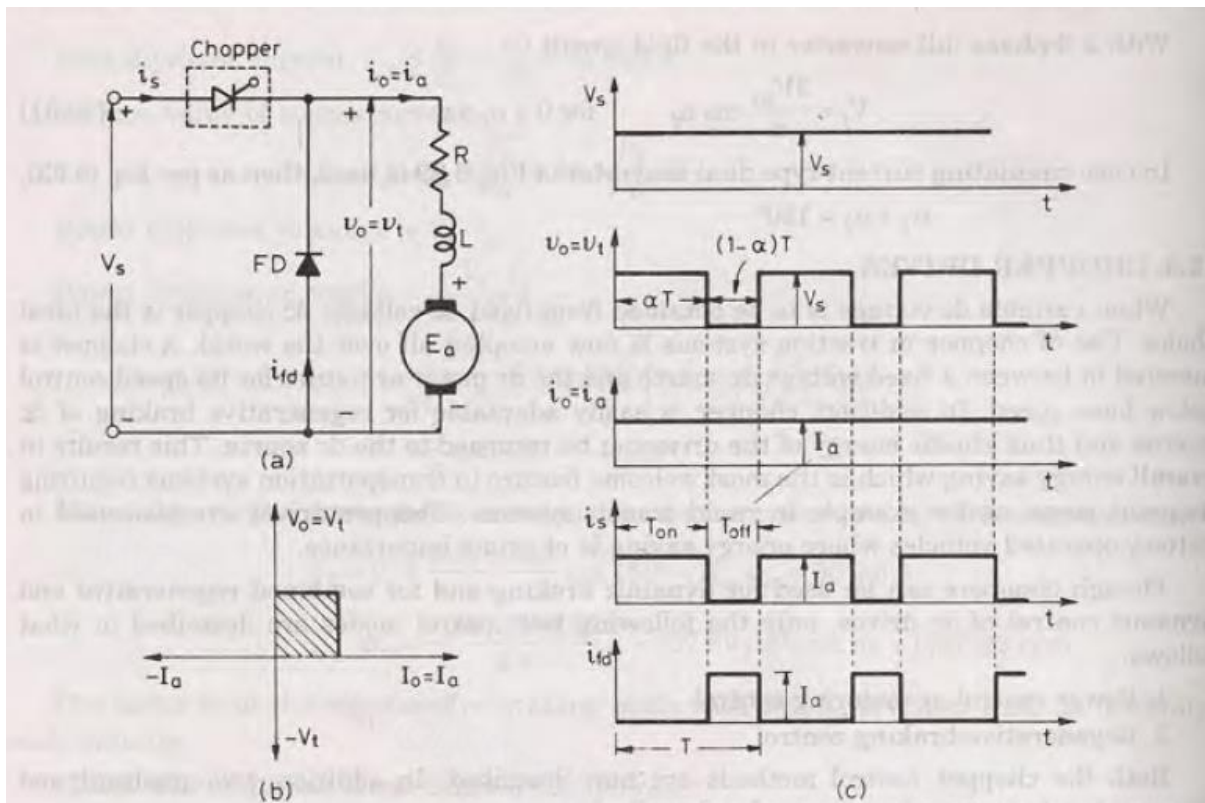


Fig. 12.20 D.C. Chopper for series motor drive (a) circuit diagram (b) quadrant diagram and (c) waveforms.

or 
$$\omega_m = \frac{\alpha V_s - I_a (r_a + r_s)}{K_m} \quad \dots(12.33)$$

It is seen from Eq. (12.33) that by varying the duty cycle  $\alpha$  of the chopper, armature terminal voltage can be controlled and thus speed of the dc motor can be regulated.

So far, armature current  $i_a$  has been assumed ripple free and accordingly, waveforms in Fig. 12.20 are sketched. Actually, the motor armature current will rise during chopper on period and fall during off period as shown in Fig. 12.21. The current expressions during on and off periods are obtained in Chapter 7 on choppers. By referring to this chopper, armature current  $i_a(t)$  during on period, from Eq. (7.10), is given by

$$i_a(t) = \frac{V_s - E_a}{R} \left( 1 - e^{-\frac{R}{L}t} \right) + I_{mn} e^{-\frac{R}{L}t} \quad \dots(12.34)$$

The armature current during the off-period, from Eq. (7.11), is given by

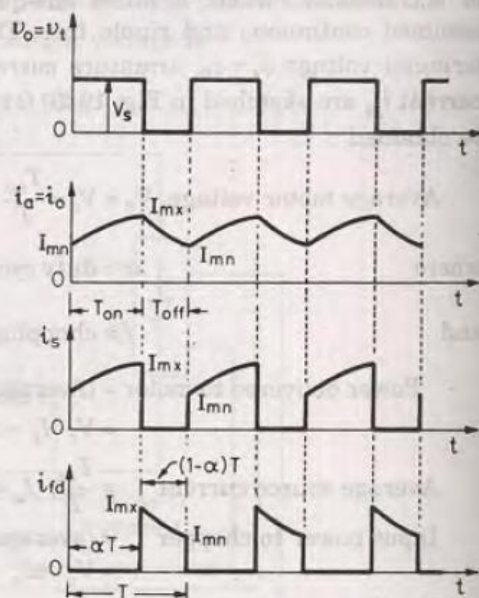


Fig. 12.21. Waveforms for dc chopper drive of Fig. 12.20 (a).

$$i_a(t) = -\frac{E_a}{R} \left( 1 - e^{-\frac{R}{L}t} \right) + I_{mx} \cdot e^{-\frac{R}{L}t} \quad \dots(12.35)$$

Here  $R = r_a$  (armature resistance) +  $r_s$  (series-field resistance)

$L = L_a$  (armature inductance) +  $L_s$  (series-field inductance)

Under steady-state operating conditions,

$$V_t = \alpha V_s = E_a + I_a R.$$

### 12.5.2. Regenerative-Braking Control

In regenerative-braking control, the motor acts as a generator and the kinetic energy of the motor and connected load is returned to the supply.

During motoring mode, armature current  $I_a = \frac{V_t - E_a}{r_a}$ , i.e. armature current is positive and the motor consumes power. In case load drives the motor at a speed such that average value of motor counter emf  $E_a (= K_m \cdot \omega_m)$  exceeds  $V_t$ ,  $I_a$  is reversed and power is delivered to the dc bus. The motor is then working as a generator in the regenerative braking mode.

The principle of regenerative braking mode is explained with the help of Fig. 12.22 (a), where a separately-excited dc motor and a chopper are shown. For active loads, such as a

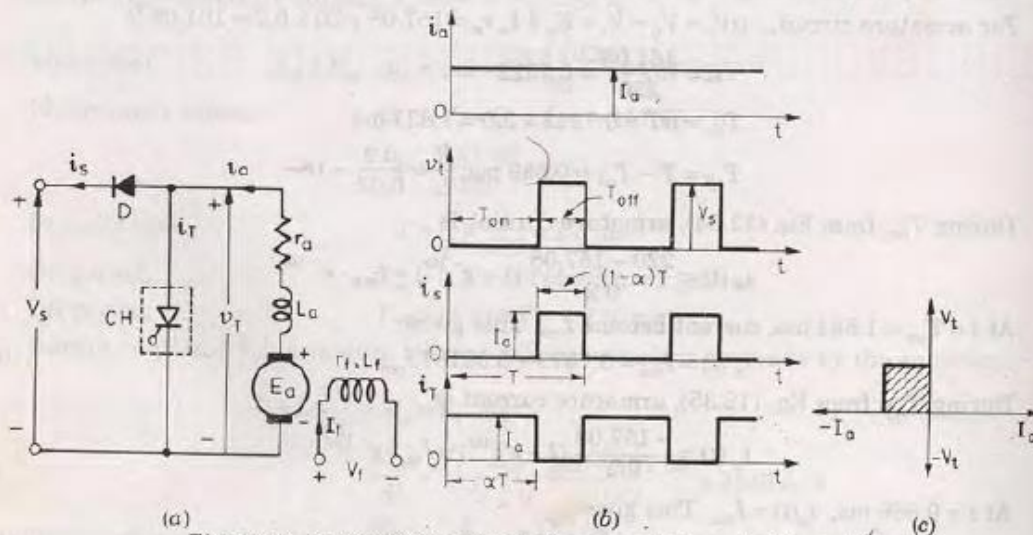


Fig. 12.22. Regenerative braking of a separately-excited dc motor  
(a) circuit diagram (b) waveforms (c) quadrant diagram.

train going down the hill or a descending hoist, let it be assumed that motor counter emf  $E_a$  is more than the source voltage  $V_s$ . When chopper CH is on, current through armature inductance  $L_a$  rises as the armature terminals get short circuited through CH. Also,  $v_t = 0$  during  $T_{on}$ . When chopper is turned off,  $E_a$  being more than source voltage  $V_s$ , diode  $D$  conducts and the energy stored in armature inductance is transferred to the source. During  $T_{off}$ ,  $v_t = V_s$ . On the assumption of continuous and ripple free armature current, the relevant voltage and current waveforms are shown in Fig. 12.22 (b).

With respect to first quadrant operation as offered by motoring control of Fig. 12.20 (a), regenerative braking control offers second quadrant operation as armature terminal voltage has the same polarity but the direction of armature current is reversed, Figs. 12.22 (a) and (c). From the waveforms of Fig. 12.22 (b), the following relations can be derived :

The average voltage across chopper (or armature terminals) is

$$V_t = \frac{T_{off}}{T} \cdot V_s = (1 - \alpha) V_s \quad \dots(12.36)$$

Power generated by the motor

$$= V_t \cdot I_a = (1 - \alpha) V_s \cdot I_a$$

Motor emf generated,  $E_a = K_m \omega_m = V_t + I_a r_a$

$$= (1 - \alpha) V_s + I_a r_a \quad \dots(12.37)$$

Motor speed during regenerative braking,

$$\omega_m = \frac{(1 - \alpha) V_s + I_a r_a}{K_m}$$

When chopper is on,  $E_a - I_a r_a - L_a \frac{di_a}{dt} = 0$

or  $(E_a - I_a r_a) = L_a \cdot \frac{di_a}{dt}$

With chopper on,  $L_a$  must store energy and current must rise, i.e.  $\frac{di_a}{dt}$  must be positive or

$$(E_a - I_a r_a) \geq 0 \quad \dots(12.38)$$

When chopper is off,  $E_a - I_a r_a - L_a \cdot \frac{di_a}{dt} = V_s$

or  $V_s - (E_a - I_a r_a) = -L_a \cdot \frac{di_a}{dt}$

With chopper off,  $(E_a - I_a r_a)$  must be more than  $V_s$  for regeneration purposes and therefore  $[V_s - (E_a - I_a r_a)]$  must be negative. This is possible only if current decreases during off period, i.e.  $\frac{di_a}{dt}$  in the above expression must be negative.

$$\therefore [V_s - (E_a - I_a r_a)] \leq 0$$

$$- (E_a - I_a r_a) \leq (-V_s)$$

or  $(E_a - I_a r_a) \leq V_s \quad \dots(12.39)$

Eqs. (12.38) and (12.39) can be combined to give

$$0 \leq (E_a - I_a r_a) \leq V_s \quad \dots(12.40)$$



Eq. (12.40) gives the conditions for the two voltages and their polarity for the regenerative braking control of dc separately-excited motor.

Minimum braking speed is obtained when  $E_a - I_a r_a = 0$

or 
$$K_m \omega_{mn} = I_a r_a$$

$\therefore$  Minimum braking speed 
$$\omega_{mn} = \frac{I_a r_a}{K_m} \quad \dots(12.41)$$

Maximum possible braking speed is obtained when

$$E_a - I_a r_a = V_s$$

$\therefore$  Maximum braking speed, 
$$\omega_{mx} = \frac{V_s + I_a r_a}{K_m} \quad \dots(12.42)$$

Thus regenerative braking control is effective only when motor speed is less than  $\omega_{mx}$  and more than  $\omega_{mn}$ . This can be expressed as

$$\omega_{mn} < \omega_m < \omega_{mx}$$

$$\frac{I_a r_a}{K_m} < \omega_m < \frac{V_s + I_a r_a}{K_m}$$

Therefore, the speed range for regenerative braking is  $\frac{V_s + I_a r_a}{K_m} : \frac{I_a r_a}{K_m}$  or  $(V_s + I_a r_a) : I_a r_a$ .

Regenerative braking of chopper-fed separately-excited dc motor is stable, it is therefore discussed here. DC series motors, however, offer unstable operating characteristics during regenerative braking. As such, regenerative braking of chopper-controlled series motors is difficult.

### List the factors affecting speed of the AC Motors

- by changing the number of poles:** one of the most generic formula of machines is  $N = 120 \times \text{frequency} / \text{number of poles}$ .  
Speed is indirectly proportional to the number of poles for a constant frequency. But please keep in mind that this method is applicable for squirrel cage rotor as here number of poles change with and are always equal to the number of stator poles, whereas the slip ring rotor has a fixed number.
- cascading the motors:** Let us say there is a motor M1 and another M2 with slips "s1" and "s2" mechanically coupled with each other. Also the stator of M2 is given supply at the frequency  $f_1 = s \cdot f$ .  
With the grid frequency "f" and synchronous speed N, the speed of the M1 rotor would be  $N_1 = (1 - s_1) \cdot N$ .  
And the speed of M2 rotor =  $(1 - s_2) \cdot N_1$   
but since the motors are mechanically coupled  $N_1 = N_2$ . Equating the above equations you would find that the speed of the rotors is equal to  $120 \cdot f / (P_1 + P_2)$ . further by changing the poles the speed can be varied. Also if the motors are differentially cascaded, speed =  $120 \cdot f / (P_1 - P_2)$
- Changing frequency:** with the available power electronic devices, a variable supply frequency to the stator can be used to control speeds. But, while we vary frequency we have to make sure that the ratio (Voltage /frequency) remains constant because

$$V = 4.44 \cdot f \cdot N \cdot \Phi, \text{ where } \Phi \text{ is the flux}$$

Therefore if the ratio is not constant the flux will vary causing either saturation at low frequencies or less than required magnetisation at high frequencies.

- Changing Supply voltage:** for low values of slip:  
Torque  $\propto \text{slip} \cdot E^2$

Hence for a constant torque the supply voltage can be varied to change the slip and the corresponding speed.

5. **Adding rotor resistance:** the rotor  
Again for constant torque and constant supply voltage :  
Torque  $\propto$  slip/R<sub>2</sub>;

So for increased resistance , the slip increases and speed decreases.

This method can be used only on slip ring induction motor and for varying speed below the Base speed.

6. **Injecting slip frequency emf on rotor side:**  
this is equivalent to adding resistance on rotor side as discussed above.

### **Speed control of three phase induction motor:**

A three phase induction motor is basically a constant speed motor so it's somewhat difficult to control its speed. The speed control of induction motor is done at the cost of decrease in efficiency and low electrical power factor. Before discussing the methods to **control the speed of three phase induction motor** one should know the basic formulas of speed and torque of three phase induction motor as the methods of speed control depends upon these formulas.

#### **Synchronous Speed**

$$N_s = \frac{120f}{P}$$

Where, f = frequency and P is the number of poles

The speed of induction motor is given by,

$$N = N_s(1 - s)$$

Where,

N is the speed of the rotor of an induction motor,

N<sub>s</sub> is the synchronous speed,

S is the slip.

The torque produced by three phase induction motor is given by,

$$T = \frac{3}{2\pi N_s} X \frac{sE_2^2 R_2}{R_2^2 + (sX_2)^2}$$

When the rotor is at standstill slip, s is one.

So the equation of torque is,

$$T = \frac{3}{2\pi N_s} X \frac{E_2^2 R_2}{R_2^2 + X_2^2}$$

Where,

E<sub>2</sub> is the rotor emf

N<sub>s</sub> is the synchronous speed

$R_2$  is the rotor resistance

$X_2$  is the rotor inductive reactance

The Speed of Induction Motor is changed from Both Stator and Rotor Side. The speed control of three phase induction motor from stator side are further classified as :

- V / f control or frequency control.
- Changing the number of stator poles.
- Controlling supply voltage.
- Adding rheostat in the stator circuit.

The speed controls of three phase induction motor from rotor side are further classified as:

- Adding external resistance on rotor side.
- Cascade control method.
- Injecting slip frequency emf into rotor side.

### **Speed Control from Stator Side**

- 
- ***V / f Control or Frequency Control***

Whenever three phase supply is given to three phase induction motor rotating magnetic field is produced which rotates at synchronous speed given by

$$N_s = \frac{120f}{P}$$

In three phase induction motor emf is induced by induction similar to that of transformer which is given by

$$E \text{ or } V = 4.44\phi K.T.f \text{ or } \phi = \frac{V}{4.44KTf}$$

Where, K is the winding constant, T is the number of turns per phase and f is frequency. Now if we change frequency synchronous speed changes but with decrease in frequency flux will increase and this change in value of flux causes saturation of rotor and stator cores which will further cause increase in no load current of the motor . So, its important to maintain flux ,  $\phi$  constant and it is only possible if we change voltage. i.e if we decrease frequency flux increases but at the same time if we decrease voltage flux will also decrease causing no change in flux and hence it remains constant. So, here we are keeping the ratio of V/f as constant. Hence its name is V/ f method. For controlling the speed of three phase induction motor by V/f method we have to supply variable voltage and frequency which is easily obtained by using converter and inverter set.

## **UPS-UNINTERRUPTABLE POWER SUPPLIES**

An **Uninterruptible Power Supply** (UPS) is defined as a piece of electrical equipment which can be used as an immediate power source to the connected load when there is any failure in the main input power source.

In a **UPS**, the energy is generally stored in flywheels, batteries, or super capacitors. When compared to other immediate power supply system, UPS have the advantage of immediate protection against the input power interruptions. It has very short on-battery run time; however this time is enough to safely shut down the connected apparatus (computers, telecommunication equipment etc) or to switch on a standby power source.

UPS can be used as a protective device for some hardware which can cause serious damage or loss with a sudden power disruption. Uninterruptible power source, Battery backup and Flywheel back up are the other names often used for UPS. The available size of UPS units ranges from 200 VA which is used for a solo computer to several large units up to 46 MVA.

### **Major Roles of UPS**

When there is any failure in main power source, the UPS will supply the power for a short time. This is the prime role of UPS. In addition to that, it can also able to correct some general power problems related to utility services in varying degrees. The problems that can be corrected are voltage spike (sustained over voltage), Noise, Quick reduction in input voltage, Harmonic distortion and the instability of frequency in mains.

### **Types of UPS**

Generally, the UPS system is categorised into On-line UPS, Off- line UPS and Line interactive UPS. Other designs include Standby on-line hybrid, Standby-Ferro, Delta conversion On-Line.

### **Off-line UPS**

This UPS is also called as Standby UPS system which can give only the most basic features. Here, the primary source is the filtered AC mains (shown in solid path in figure 1). When the power breakage occurs, the transfer switch will select the backup source (shown in dashed path in figure 1). Thus we can clearly see that the stand by system will start working only when there is any failure in mains. In this system, the AC voltage is first rectified and stored in the storage battery connected to the rectifier.

When power breakage occurs, this DC voltage is converted to AC voltage by means of a power inverter, and is transferred to the load connected to it. This is the least expensive UPS system and it provides surge protection in addition to back up. The transfer time can be about 25 milliseconds which can be related to the time taken by the UPS system to detect the utility voltage that is lost.

The block diagram is shown below.

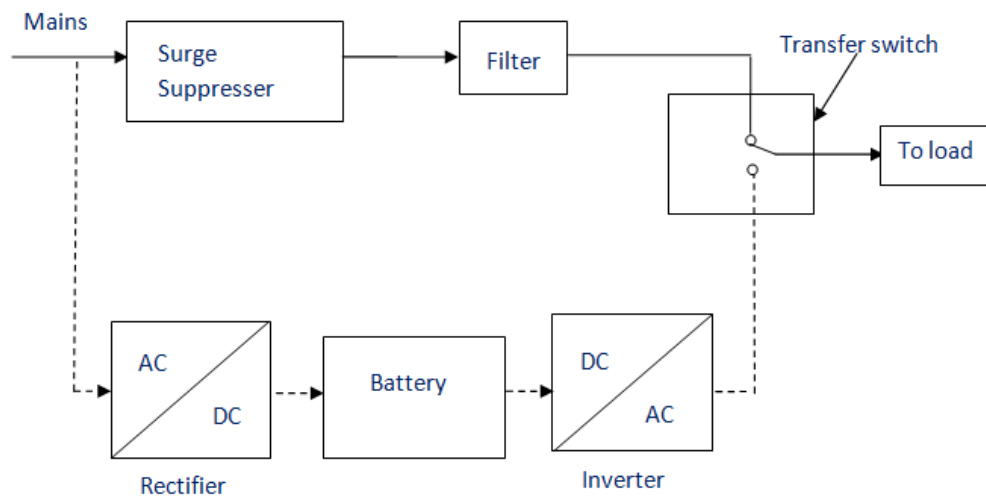


Figure 1

### On-line UPS

In this **type of UPS**, double conversion method is used. Here, first the AC input is converted into DC by rectifying process for storing it in the rechargeable battery. This DC is converted into AC by the process of inversion and given to the load or equipment which it is connected (figure 2). This type of UPS is used where electrical isolation is mandatory. This system is a bit more costly due to the design of constantly running converters and cooling systems. Here, the rectifier which is powered with the normal AC current is directly driving the inverter. Hence it is also known as Double conversion UPS. The block diagram is shown below.

When there is any power failure, the rectifier have no role in the circuit and the steady power stored in the batteries which is connected to the inverter is given to the load by means of transfer switch. Once the power is restored, the rectifier begins to charge the batteries. To prevent the batteries from overheating due to the high power rectifier, the charging current is limited. During a main power breakdown, this UPS system operates with zero transfer time. The reason is that the backup source acts as a primary source and not the main AC input. But the presence of inrush current and large load step current can result in a transfer time of about 4-6 milliseconds in this system.



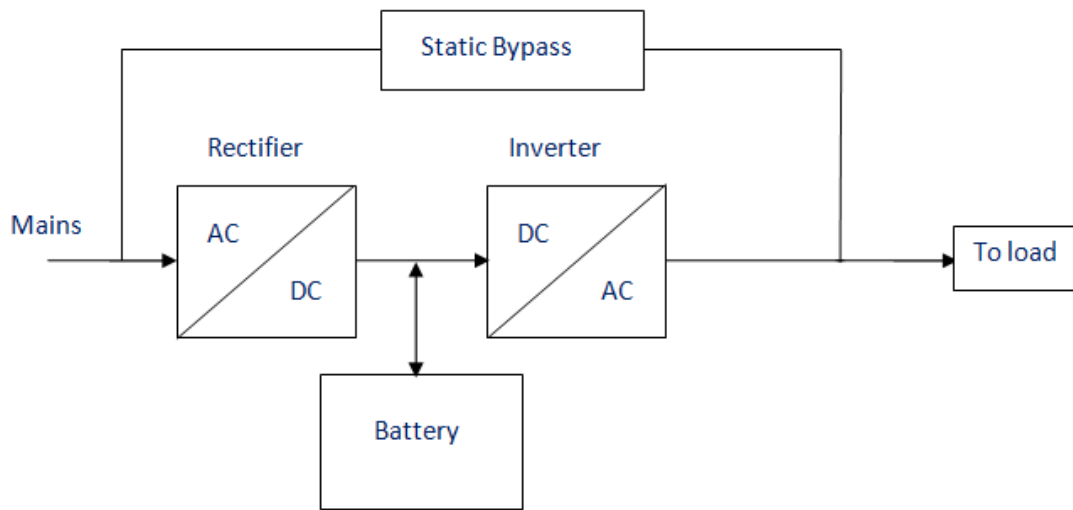


Figure 2

### Line Interactive UPS

For small business and departmental servers and webs, line interactive UPS is used. This is more or less same as that of off-line UPS. The difference is the addition of tap changing transformer. Voltage regulation is done by this tap-changing transformer by changing the tap depending on input voltage. Additional filtering is provided in this UPS result in lower transient loss. The block diagram is shown below.

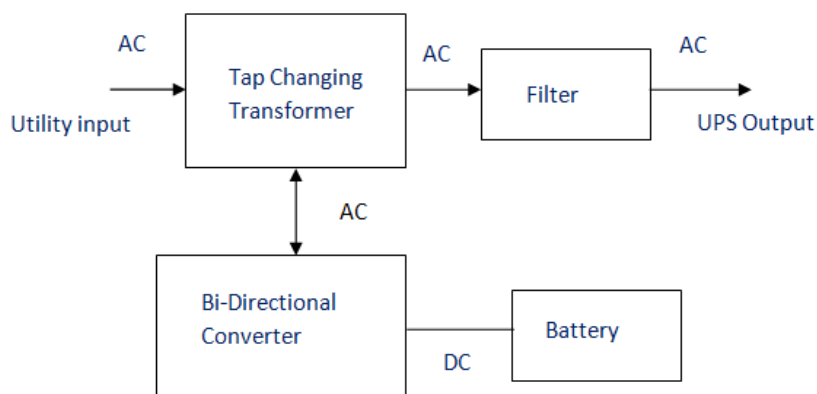


Figure 3

### UPS Applications

Applications of a UPS include:

- Data Centers
- Industries
- Telecommunications
- Hospitals
- Banks and insurance
- Some special projects (events)

You can learn more about UPS's and other electrical equipment by studying our free [basic electrical questions](#).

## Linear Power Supply

The Linear Power Supply LPSLPS is the regulated power supply which dissipates much heat in the series resistor to regulate the output voltage which has low ripple and low noise. This LPS has many applications.

A linear power supply requires larger semiconductor devices to regulate the output voltage and generates more heat resulting in lower energy efficiency. Linear power supplies have transient response times up to 100 times faster than the others, which is very important in certain specialized areas.

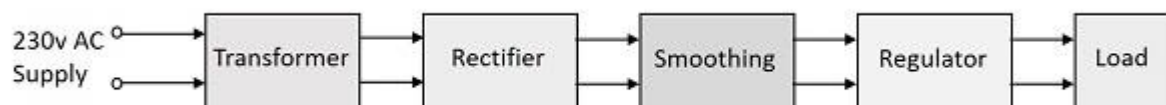
### Advantages of LPS

- The power supply is continuous.
- The circuitry is simple.
- These are reliable systems.
- This system dynamically responds to load changes.
- The circuit resistances are changed to regulate the output voltage.
- As the components operate in linear region, the noise is low.
- The ripple is very low in the output voltage.

### Disadvantages of LPS

- The transformers used are heavier and large.
- The heat dissipation is more.
- The efficiency of linear power supply is 40 to 50%
- Power is wasted in the form of heat in LPS circuits.
- Single output voltage is obtained.

We have already gone through different parts of a Linear Power supply. The block diagram of a Linear Power Supply is as shown in the following figure.



In spite of the above disadvantages, Linear Power Supplies are widely used in low-noise amplifiers, test equipment, control circuits. In addition, they are also used in data acquisition and signal processing.

All the power supply systems that needs simple regulation and where efficiency is not a concern, the LPS circuits are used. As the electrical noise is lower, the LPS is used in powering sensitive analog circuitry. But to overcome the disadvantages of Linear Power Supply system, the Switched Mode Power Supply SMPSSMPS is used.

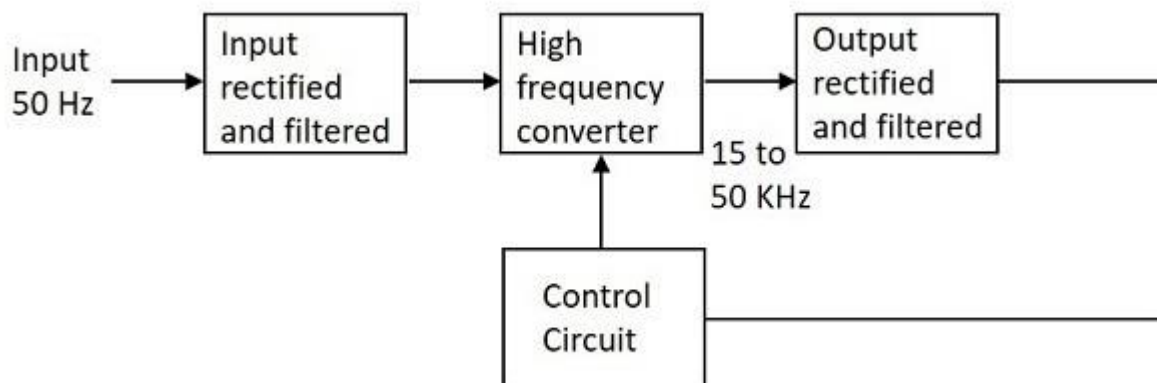
## Switched Mode Power Supply (SMPS):

The disadvantages of LPS such as lower efficiency, the need for large value of capacitors to reduce ripples and heavy and costly transformers etc. are overcome by the implementation of **Switched Mode Power Supplies**.

The working of SMPS is simply understood by knowing that the transistor used in LPS is used to control the voltage drop while the transistor in SMPS is used as a **controlled switch**.

### Working

The working of SMPS can be understood by the following figure.



Let us try to understand what happens at each stage of SMPS circuit.

### Input Stage

The AC input supply signal 50 Hz is given directly to the rectifier and filter circuit combination without using any transformer. This output will have many variations and the capacitance value of the capacitor should be higher to handle the input fluctuations. This unregulated dc is given to the central switching section of SMPS.

### Switching Section

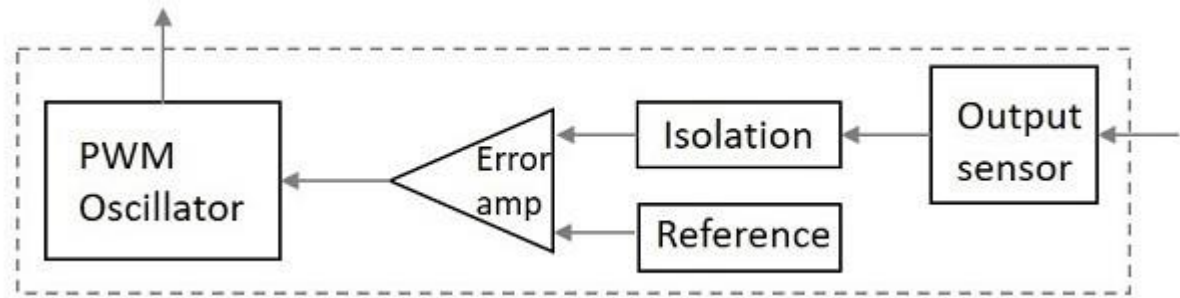
A fast switching device such as a Power transistor or a MOSFET is employed in this section, which switches ON and OFF according to the variations and this output is given to the primary of the transformer present in this section. The transformer used here are much smaller and lighter ones unlike the ones used for 60 Hz supply. These are much efficient and hence the power conversion ratio is higher.

### Output Stage

The output signal from the switching section is again rectified and filtered, to get the required DC voltage. This is a regulated output voltage which is then given to the control circuit, which is a feedback circuit. The final output is obtained after considering the feedback signal.

### Control Unit

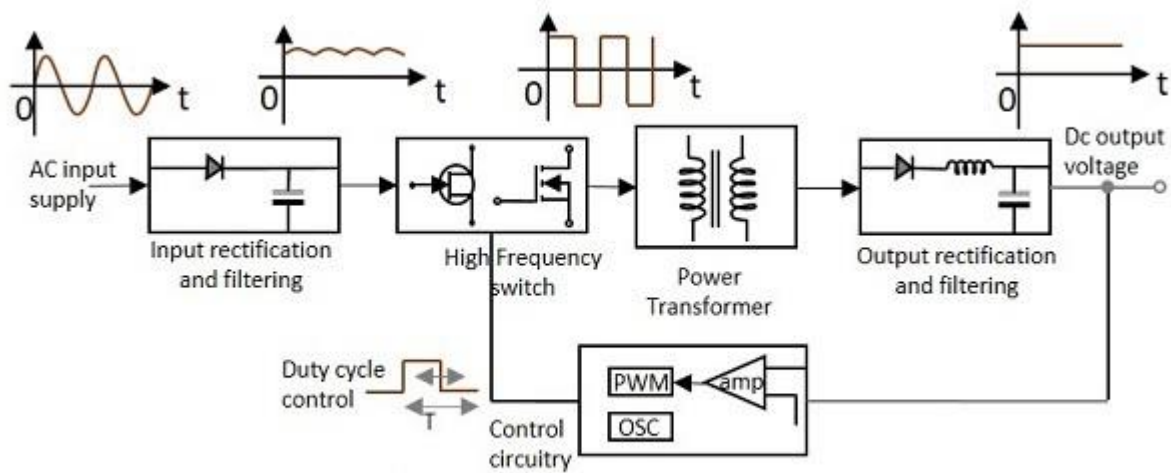
This unit is the feedback circuit which has many sections. Let us have a clear understanding about this from The following figure.



The above figure explains the inner parts of a control unit. The output sensor senses the signal and joins it to the control unit. The signal is isolated from the other section so that any sudden spikes should not affect the circuitry. A reference voltage is given as one input along with the signal to the error amplifier which is a comparator that compares the signal with the required signal level.

By controlling the chopping frequency the final voltage level is maintained. This is controlled by comparing the inputs given to the error amplifier, whose output helps to decide whether to increase or decrease the chopping frequency. The PWM oscillator produces a standard PWM wave fixed frequency.

We can get a better idea on the complete functioning of SMPS by having a look at the following figure.



**Functional block diagram of SMPS**

The SMPS is mostly used where switching of voltages is not at all a problem and where efficiency of the system really matters. There are few points which are to be noted regarding SMPS. They are

- SMPS circuit is operated by switching and hence the voltages vary continuously.
- The switching device is operated in saturation or cut off mode.
- The output voltage is controlled by the switching time of the feedback circuitry.
- Switching time is adjusted by adjusting the duty cycle.
- The efficiency of SMPS is high because, instead of dissipating excess power as heat, it continuously switches its input to control the output.

## Disadvantages

There are few disadvantages in SMPS, such as

- The noise is present due to high frequency switching.
- The circuit is complex.
- It produces electromagnetic interference.

## Advantages

The advantages of SMPS include,

- The efficiency is as high as 80 to 90%
- Less heat generation; less power wastage.
- Reduced harmonic feedback into the supply mains.
- The device is compact and small in size.
- The manufacturing cost is reduced.
- Provision for providing the required number of voltages.

## Applications

There are many applications of SMPS. They are used in the motherboard of computers, mobile phone chargers, HVDC measurements, battery chargers, central power distribution, motor vehicles, consumer electronics, laptops, security systems, space stations, etc.

## Types of SMPS

SMPS is the Switched Mode Power Supply circuit which is designed for obtaining the regulated DC output voltage from an unregulated DC or AC voltage. There are four main types of SMPS such as

- DC to DC Converter
- AC to DC Converter
- Fly back Converter
- Forward Converter

The AC to DC conversion part in the input section makes the difference between AC to DC converter and DC to DC converter. The Fly back converter is used for Low power applications. Also there are Buck Converter and Boost converter in the SMPS types which decrease or increase the output voltage depending upon the requirements. The other type of SMPS include Self-oscillating fly-back converter, Buck-boost converter, Cuk, Sepic, etc.

## Battery Charger Circuit Using SCR:

The battery is charged with small amount of AC voltage or DC voltage. So if you want to charge your battery with AC source then should follow these steps, we need first limit the large AC voltage, need to filter the AC voltage to remove the noise, regulate and get the constant voltage and then give the resulting voltage to the battery for charging. Once charging is completed the circuit should automatically turned off.

## Block Diagram of Battery Charger Using SCR:

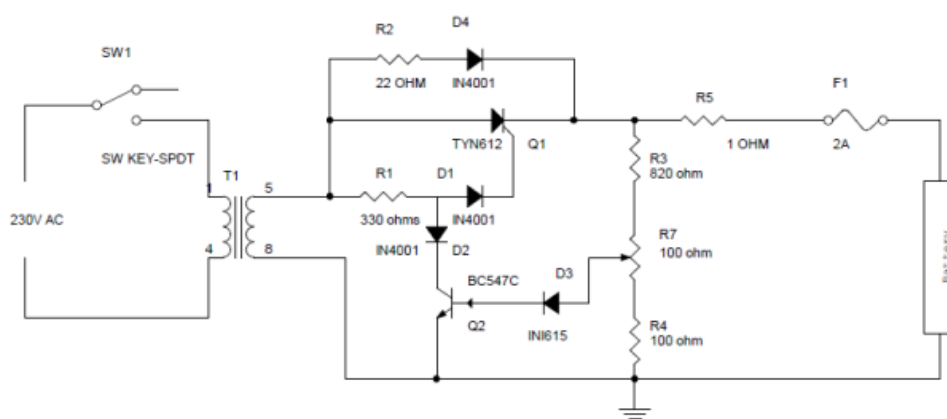


Block Diagram of Battery Charger Using SCR

The AC source is given to the step down transformer which converts the large AC source into limited AC source, filter the AC voltage and remove the noise and then give that voltage to the SCR where it will rectify the AC and give the resulting voltage to the battery for charging.

## Circuit Diagram of Battery Charger Using SCR:

Circuit diagram of the Battery Charger Circuit using SCR can be seen below



## Circuit Diagram Explanation

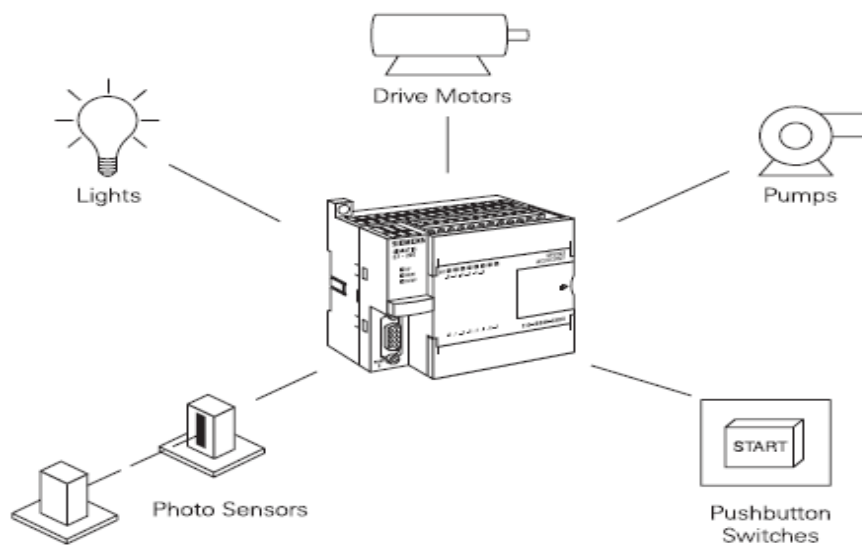
- The AC main voltage is given to the step down transformer the voltage should be down to 20V approx. the step down voltage is given to the SCR for rectification and SCR rectifies AC main voltage. This rectified voltage is used to charge battery.
- When the battery connector to the charging circuit, the battery will not be dead completely and it will get discharged this will give the forward bias voltage to the transistor through the diode D2 and resistor R7 which will get turned on. When the transistor is turned on the SCR will get off.
- When the battery voltage is dropped the forward bias will be decreased and transistor gets turned off. When the transistor is turned off automatically the diode D1 and resistor R3 will get the current to the gate of the SCR, this will triggers the SCR and gets conduct. SCR will rectifies the AC input voltage and give to the battery through Resistor R6.
- This will charge the battery when the voltage drop in the battery decreases the forward bias current also gets increased to the transistor when the battery is completely charged the Transistor Q1 will be again turned on and turned off the SCR.

## Chapter-5

### PLC AND ITS APPLICATIONS

#### INTRODUCTION:

Programmable Logic Controllers (PLCs), also referred to as programmable controllers, are in the computer family. They are used in commercial and industrial applications. A PLC monitors inputs, makes decisions based on its program, and controls outputs to automate a process or machine. This course is meant to supply you with basic information on the functions and configurations of PLCs.

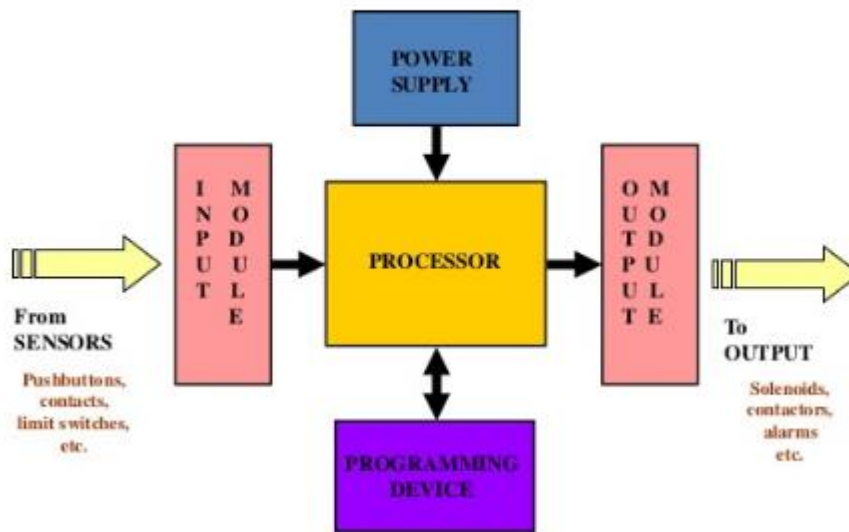


#### **Basic PLC Operation:**

PLCs consist of input modules or points, a Central Processing Unit (CPU), and output modules or points. An input accepts a variety of digital or analog signals from various field devices (sensors) and converts them into a logic signal that can be used by the CPU. The CPU makes decisions and executes control instructions based on program instructions in memory. Output modules convert control instructions from the CPU into a digital or analog signal that can be used to control various field devices (actuators). A programming device is used to input the desired instructions. These instructions determine what the PLC will do for a specific input. An operator interface device allows process information to be displayed and new control parameters to be entered.

#### Block diagram of PLC:

## PLC BLOCK DIAGRAM



- **Processor section (CPU)**

The processor section is the brain of the PLC, which consists of RAM, ROM, logic solver, and user memory. The central processing unit is the heart of the PLC. The CPU controls monitors and supervises all operations within the PLC. The CPU makes decisions and executes control instructions based on the program instructions in memory.

- **Input and output module**

The input module is a mediator between input devices and the central processing unit (CPU), which is used to convert analog signals into digital signals.

The output module is a mediator between output devices and the central processing unit (CPU), which is used to convert digital signals into analog signals.

- **Power supply**

Power supply is provided to the processor unit, input and output module unit. Power supply may be integral or separately mounted unit. Most PLCs operate on 0 volts DC and 24 volts.

- **Memory section**

The memory section is the area of the CPU in which data and information is stored and retrieved. Data Memory is used to store numerical data required in math calculations, bar code data, etc. User memory contains the user's application program.

- **Programming device**

Programming devices are dedicated devices used for loading the user program into the program memory or editing it and to monitor the execution of the program of the PLC. It is also used to troubleshoot the PLC ladder logic program. Hand-held terminal (HHT) or dedicated terminal or personal computer are programming devices commonly used in most PLCs.



### Advantages of PLC

1. **Reduced space** : PLCs are completely solid state devices and hence are extremely compact in comparison to hard-wired controller where electro-mechanical devices are used.2.
2. **Higher Life and Reliability** : These devices are extremely rugged. The chances of defect/damage are very less as there is very lesser moving mechanisms here.
3. **Economical** : As the defect probability is very less, One can consider it as one time investment. In this way, PLCs are undoubtedly most economical systems. Cost of PLC recovers within a short period.
4. **Energy saving** : Average power consumption is just 1/10th of power consumed by an equivalent relay based control.5.
5. **Ease of maintenance:**
  - Modular replacement
  - Easy trouble shooting
  - Error diagnostics with programming unit.
6. **Tremendous flexibility** : There is no requirement of rewiring if any change is required to be implemented. It can carry out complex functions like arithmetic operations, counting, comparing, generation of time delay etc. It has a very high processing speed and greater flexibility in both analog and digital process. "On Line"/ 'Off Line' programming is also possible in it.
  7. **Shorter Project Time** : The hard wired control system can be constructed only when the task is fully defined. However, In case of PLC , the construction of the controller and wiring are independent of control program definition.
  8. **Easier Storage Archiving and Documentation** : This is due to its compatibility with PC-AT, Printer and Floppy disk.

However, if we compare Programmable logic controller function with computers, it has following advantages and disadvantages :

#### Advantage :

- many inputs and outputs, excellent for controlling and monitoring many processes.
- designed for industrial environments, very robust and reliable.
- reprogrammable.
- modular.
- ideally suited to supervisory control.
- easy to set up and good for FMS environment.

### **Application of PLC:**

Because of the versatility of PLC, it is used in various places for automation. In industries various processes need to be controlled at every instant of time such as valve control, pressure control, robotic action, etc. It becomes tedious and infeasible for humans to control all such activities on their own. Thus relays were used to perform those activities. However, a relay can be used only for a specific and limited operation which makes their use bulky and uneconomic. On the contrary PLC having the ability to perform number of tasks by simply modifying the program has become a prominent device for automation of such activities. There are various places where a PLC can be used. Some of those are listed as below:

- Robotic arm in car manufacturing
- Air compressors
- Airport runway lighting control
- Traffic signal control
- Smoke alarm control
- Process valve control
- Textile equipments
- Vacuum pump system

Apart from these applications, PLC is widely used in automation of electrical power system. At electrical substations automatic reclosing, circuit breaker tripping, capacitor switching, etc. can be controlled with PLCs.

### **Ladder Diagram:**

A **ladder diagram** is a type of schematic diagram used in industrial automation that represents logic control circuits. Ladder diagrams are composed of two vertical power rails and horizontal logic rungs to form what looks like a ladder. The control logic in a ladder diagram is contained within the rungs.

There are two differences between an electrical schematic and a ladder diagram. The first difference is the control logic in an electrical schematic is represented using components whereas in a ladder diagram symbols are used. The second difference is the control logic execution in an electrical schematic is as per the operation of an electrical circuit whereas in a ladder diagram it relies on the methodical nature of the PLC scan.

Why is a ladder diagram used for PLC programming?

The reason why ladder diagrams are used for PLC programming is because the early control system designers were accustomed to relay logic control circuits and ladder diagrams closely mimic these. They preferred to use ladder diagrams instead using text based programming languages of the day like C, BASIC, Pascal and FORTRAN. The other reason ladder diagrams are used is because factory maintenance staff already understand how to read relay control circuits so using ladder diagrams for programming a PLC meant they were easily able to troubleshooting control system problems.

Ladder diagrams help you to formulate the logic expressions in graphical form that are required to program a PLC. They represent conditional, input and output expressions as

symbols. So writing a PLC program using ladder diagrams is similar to drawing a relay control circuit.

## How to Draw Ladder Logic Diagrams

The simple way to describe a ladder diagram is a graphic programming language that uses a series of rails and rungs containing logic symbols that are combined to form decision making expressions. Ladder diagrams actually look like a ladder and are more commonly known as ladder logic programming.

The rails in a ladder diagram represent the supply wires of a relay logic control circuit. There is a positive voltage supply rail on the left hand side and a zero voltage rail on the right hand side. In a ladder diagram the logic flow is from the left hand rail to the right hand rail.

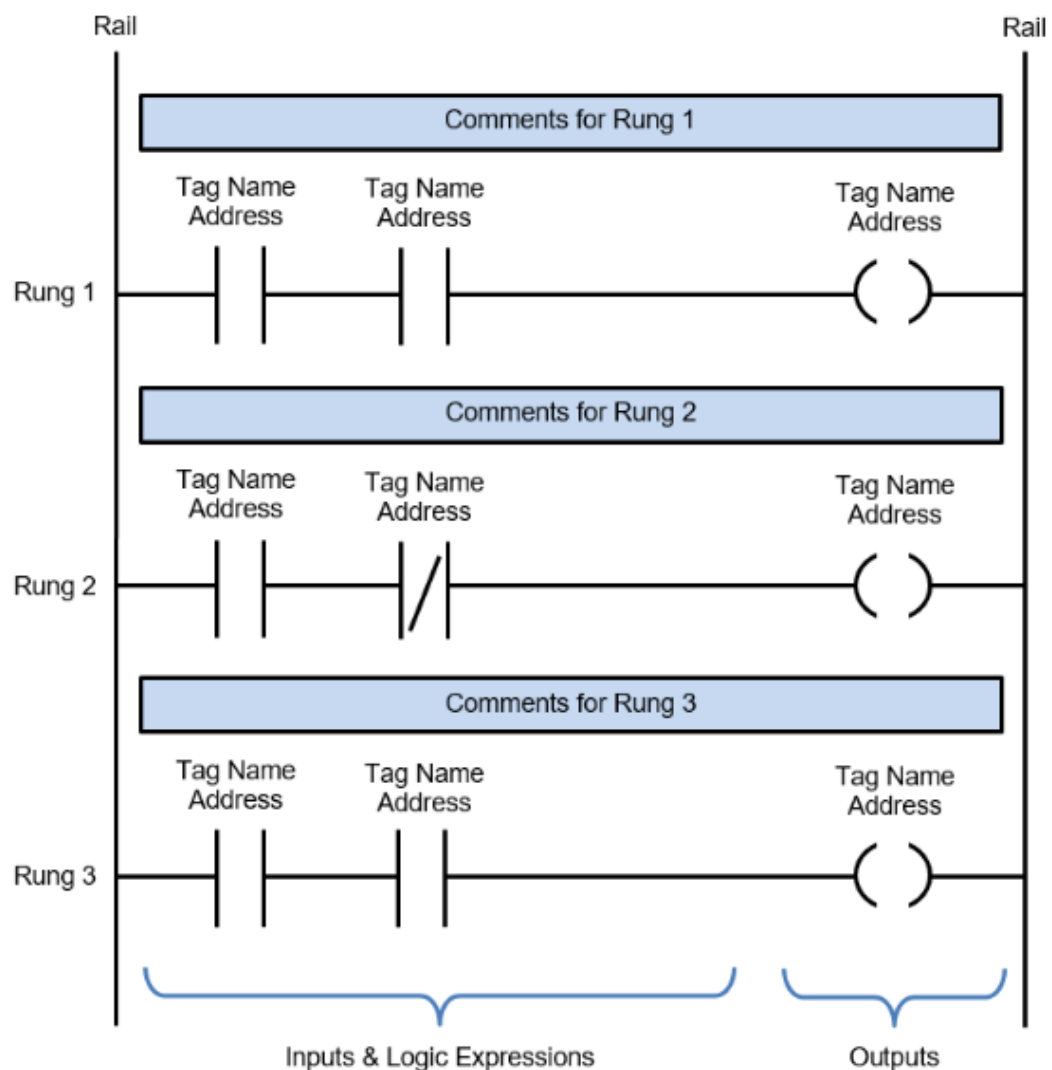
The rungs in a ladder diagram represent the wires that connect the components of a relay control circuit. In a ladder diagram symbols are used to represent the relay components. The symbols are placed in the rung to form a network of logic expressions.

When implementing a ladder logic program in a PLC there are **seven basic parts of a ladder diagram** that critical to know. They are rails, rungs, inputs, outputs, logic expressions, address notation/tag names and comments. Some of these elements are essential and others are optional.

To help understand **how to draw ladder logic diagrams** the seven basic parts of a ladder diagram are detailed below.....

1. **Rails** – There are two rails in a ladder diagram which are drawn as vertical lines running down the far most ends of the page. If they were in a relay logic circuit they would represent the active and zero volt connections of the power supply where the power flow goes from the left hand side to the right hand side.
2. **Rungs** – The rungs are drawn as horizontal lines and connect the rails to the logic expressions. If they were in a relay logic circuit they would represent the wires that connect the power supply to the switching and relay components.
3. **Inputs** – The inputs are external control actions such as a push button being pressed or a limit switch being triggered. The inputs are actually hardwired to the PLC terminals and represented in the ladder diagram by a normally open (NO) or normally closed (NC) contact symbol.

4. **Outputs** – The outputs are external devices that being are turned on and off such as an electric motor or a solenoid valve. The outputs are also hardwired to the PLC terminals and are represented in the ladder diagram by a relay coil symbol.
5. **Logic Expressions** – The logic expressions are used in combination with the inputs and outputs to formulate the desired control operations.
6. **Address Notation & Tag Names** – The address notation describes the input, output and logic expression memory addressing structure of the PLC. The tag names are the descriptions allocated to the addresses.
7. **Comments** – Last but by not least, the comments are an extremely important part of a ladder diagram. Comments are displayed at the start of each rung and are used to describe the logical expressions and control operations that the rung, or groups of rungs, are executing. Understanding ladder diagrams is made a lot easier by using comments.



	Normally open	Normally closed		
			Relay coil	
			Type "A" contact	
			Type "B" contact	
			Form "C" contacts	
Momentary pushbutton			Indicator lamp letter indicates color	
Limit switch			Thermal overload	
Pressure switch			Control circuit fuse	
Level switch				
Flow switch				
Temperature switch				
Timer contacts	Delay after coil pickup			
	Delay after coil dropout			
			Three-phase drawout-type circuit breaker	

# Ladder Logic Symbols

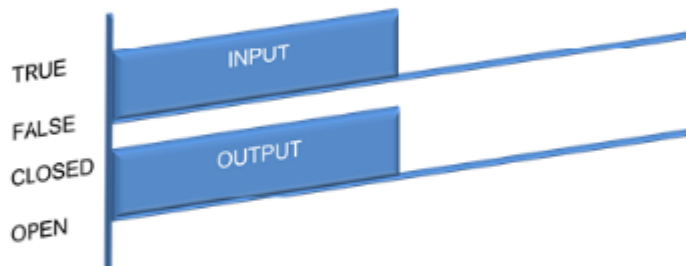
The ladder logic symbols that are used in ladder logic programming have been derived from traditional relay logic control circuits. If you have a basic knowledge of electric circuits then getting started in ladder logic programming should be a breeze.

# Normally Open Contact



## Operation:

If the condition is TRUE then the expression is CLOSED.



*Normally Open Contact – State Diagram*

## Common Uses:

Start Push buttons.

Selector switches.

Digital instrumentation.

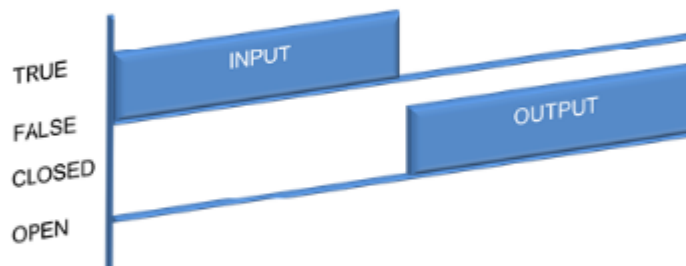
Internal programming.

# Normally Closed Contact



## Operation:

If the condition is TRUE then the contact is OPEN.



*Normally Closed Contact -State Diagram*

## Common uses:

Stop Push buttons.

Fail safe instrumentation.

Motor Thermal Overloads.

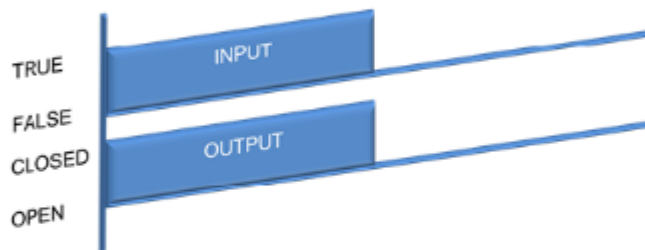
Internal programming.

# Output



## Operation:

If the input condition is TRUE then the output is ON.



*Output - State Diagram*

## Common uses:

Motor Contactors.

Actuators.

Indication lamps.

Warning sirens.

Internal programming.

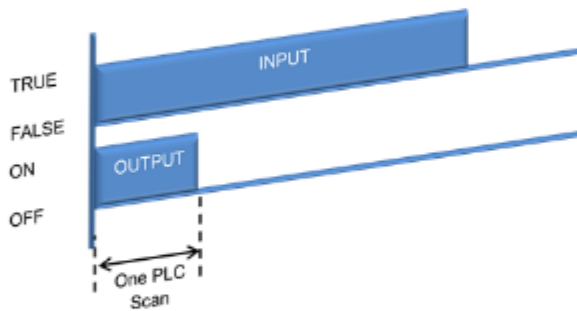


## One Shot – Positive Edge Detection



### Operation:

If the input condition transitions from FALSE to TRUE then the output is ON, for the time taken to do one PLC program scan.



One Shot – State Diagram

### Common uses:

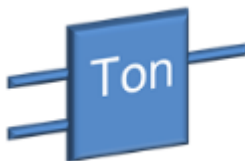
Counting applications.

Math commands.

Data Transfer commands.

Latch output during a specific set of conditions.

## Timer Delay On

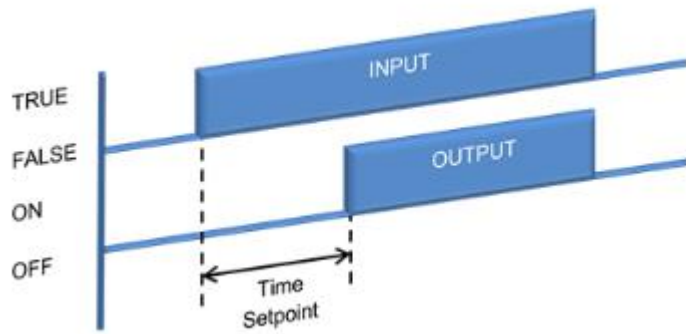


### Operation:

If the input condition is TRUE then the timer begins.

When the pre-set time has been reached the output turns ON.

If the input condition goes FALSE, at any stage, the timer stops and the output turns OFF as well



**Common uses:**

Time delay for Sirens.

Star/Delta Motor Starters.

Sequence start delays.

De-bounce time delay to fix digital instrumentation flicker.

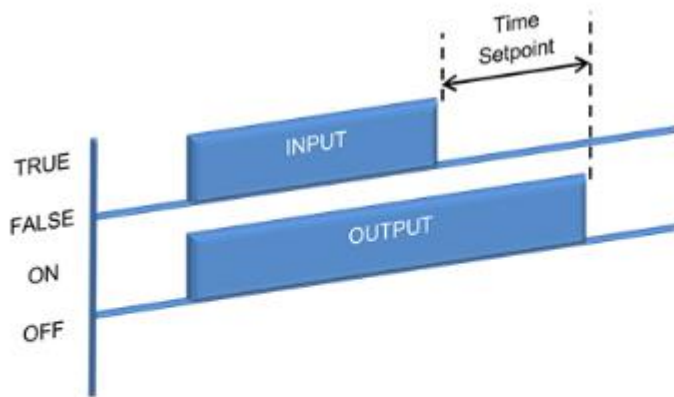
## Timer Delay Off



**Operation:**

If the input condition is TRUE then the output turns ON.

Then if the input condition goes FALSE the timer begins.



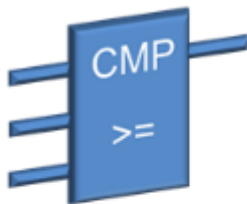
Timer Delay Off – State Diagram

**Common Uses:**

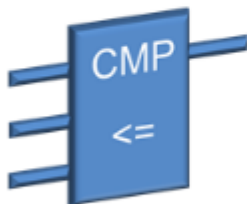
Run on time Delay

## Comparison –

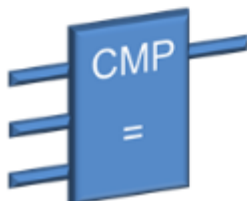
### Greater Than or Equal To



### Less Than or Equal To

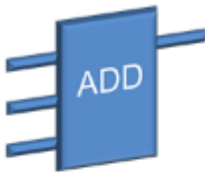


### Equal To

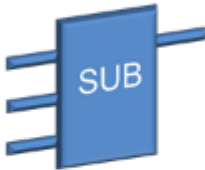


## Math Instructions –

### Addition



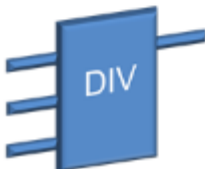
### Subtraction



### Multiplication

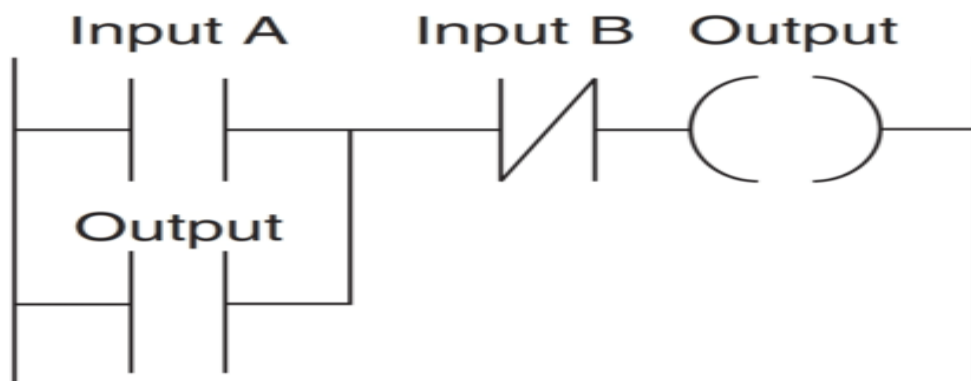


### Division



## PLC Latching Function

An example of a latch circuit is shown in Figure 1.18. When the input A contacts close, there is an output. However, when there is an output, another set of contacts associated with the output closes.

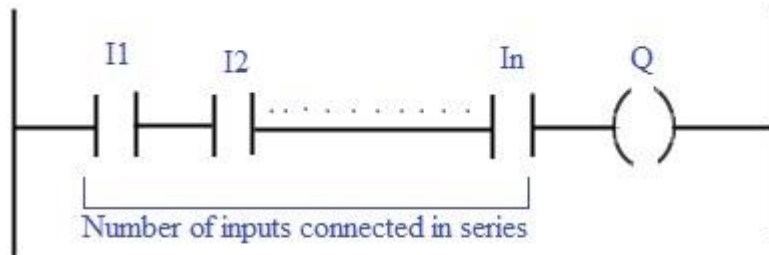


## Branches

There are three types of branches. They are as follows.

### 1. Series Branch:

In the series branch, inputs or outputs are connected in the series.

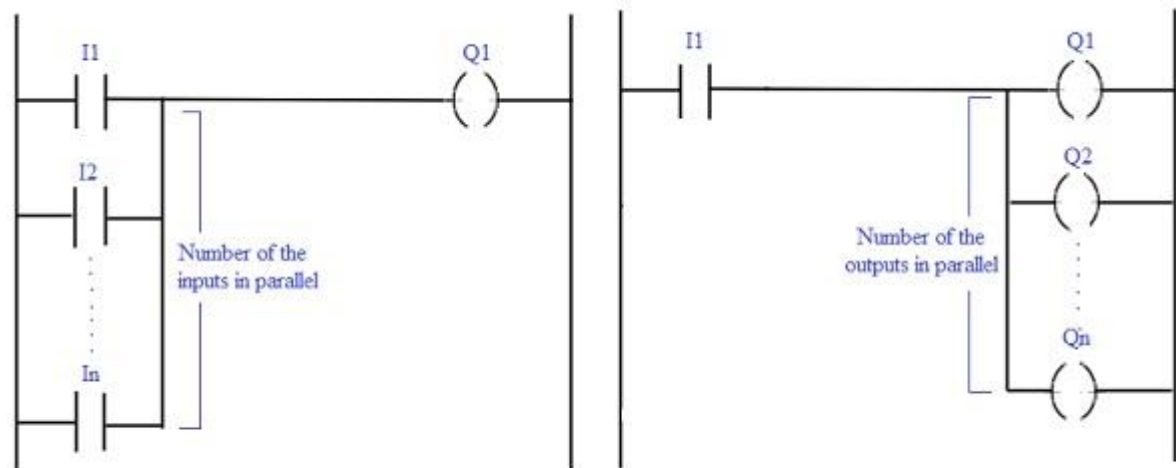


**Figure: Representation of the Series Branch**

DipsLab.com

### 2. Parallel Branch:

In the parallel branch, inputs or outputs are connected parallelly.

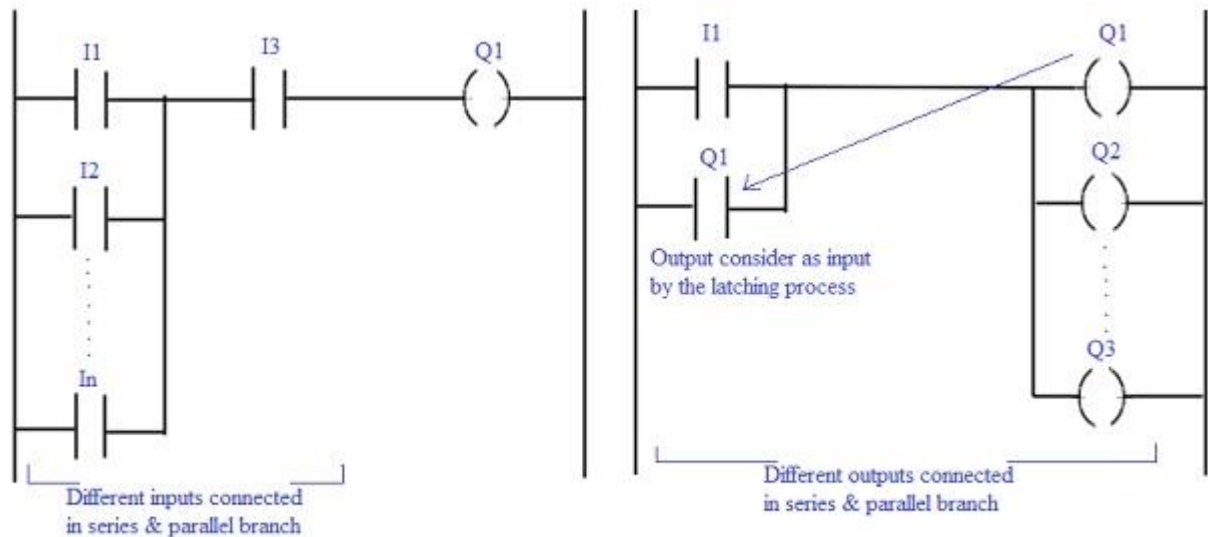


**Figure: Representation of the Parallel Branch**

DipsLab.com

### 3. Nest Branch:

The combination of series and parallel branches in the same or different rungs are called as Nest Branch.



**Figure: Representation of Nest Branch**

DipsLab.com

## Read Ladder Logic

Microprocessors like the ones found in PLC's and personal computers operate on the binary concept.

You've probably heard of the term 'binary'. It refers to the principle that things can be thought of in one of two states. The states can be defined as :

1 or 0

True or False

On or Off

High or Low

Yes or No

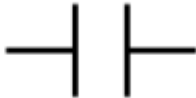

Luckily ladder logic uses symbolic expressions and a graphical editor for writing and reading ladder diagrams making it easier for us mere humans to comprehend. If we translate a real world event into ladder logic we can express it symbolically in the form of a normally open (NO) contact. This event

could be something like a button being pushed or a limit switch being activated.

Let's call it event 'A'. It follows the binary concept and has one of two states, TRUE or FALSE.

The event associated with the normally open (NO) contact can be TRUE or FALSE. When that event is TRUE then it is highlighted green and the logic flow can move past it to the next logic expression. Just like the current flow in an electric circuit when a switch is turned on.

The ladder logic truth table for a normally open (NO) contact which denotes event 'A' is shown below....

	A
FALSE	
TRUE	

*Ladder Logic Truth Table - Normally Open (NO) Contact*

A normally open (NO) contact alone cannot decide what action to take to automate something,

Binary concept – Cold or Hot, Sweater On or Sweater Off.

Logic concept – IF, THEN logic functions.

Binary logic in action!

**The binary and logic concepts are what makes ladder logic work. The hidden key to unlock your understanding of how ladder logic works is**

that the **IF, THEN** logic functions are automatically built into the structure of the ladder diagram.

Let me show you.....

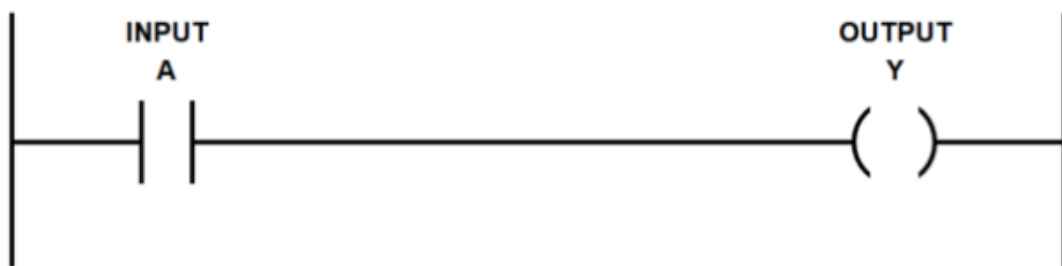
## Ladder Logic Functions

Let's take a real world event, allocate it to a normally closed (NC) contact and call it 'A'. In ladder logic the real world events are defined as PLC inputs.

Now, let's call the result of the logic function 'Y'. In ladder logic the result of a rung logic function is defined as a PLC output.

When we take these two fundamental elements and insert them into a rung in a ladder diagram we get your first line of code!

It's equivalent to "Hello World" in other programming languages.....



Because PLC input A follows the binary concept it has two possible states, TRUE or FALSE.

Therefore it results in two possible logic iterations:



**IF A = FALSE THEN Y = FALSE**

**IF A = TRUE THEN Y = TRUE**

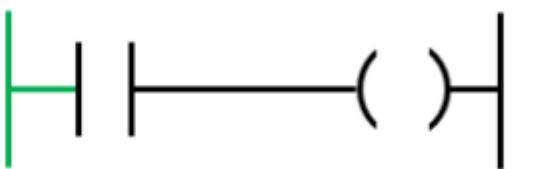

We also can express this in a truth table....

INPUT	OUTPUT
A	Y
FALSE	FALSE
TRUE	TRUE

*Truth Table*

If we translate this into a ladder logic diagram we express it symbolically in the form of a normally open (NO) contact for the input and a relay coil for the output. Remember the logic flow is from left to right and follows the same concept of current flow in an electric circuit.

The ladder logic truth table is shown below....

	INPUT	OUTPUT
	A	Y
A= FALSE		
A= TRUE		

The three functions are:

1. NOT
2. AND
3. OR

## Ladder Logic NOT Function

The result of the NOT function is basically the opposite state of an event that occurs.

So if PLC input A is FALSE the result will be TRUE. And vice versa when PLC input A is TRUE the result will be FALSE.





The NOT Function is sometimes referred to as reverse logic. Check out the truth table below....

A	NOT A
FALSE	TRUE
TRUE	FALSE

*Truth Table - NOT Function*

If we translate a NOT function into a ladder logic diagram we express it symbolically in the form of a normally closed (NC) contact.

The ladder logic truth table is shown below....

	A	NOT A
FALSE		
TRUE		

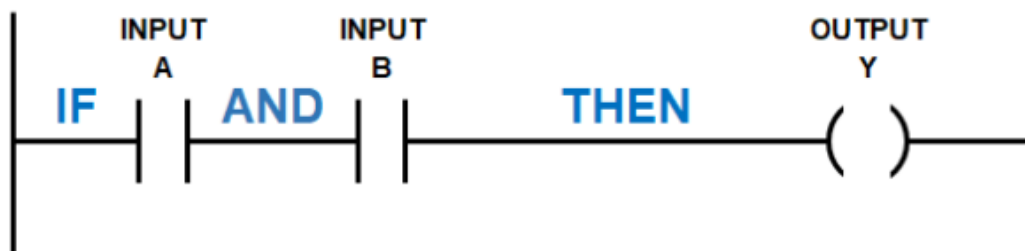
*Ladder Logic Basics Truth Table - NOT Function*

## Ladder Logic AND Function

The AND function examines multiple PLC inputs and has one resulting output.

If we translate an AND function into a ladder diagram we can express it symbolically in the form of two normally open (NO) contacts (PLC inputs A and B) and a relay coil (PLC output Y).

They are all connected in line, just like a series connection in an electric circuit.



*Ladder Logic Basics – AND Function*

The AND function examines if all the PLC inputs are TRUE, then the corresponding result is also TRUE. However if any one of the PLC inputs is FALSE then the corresponding result is also FALSE.

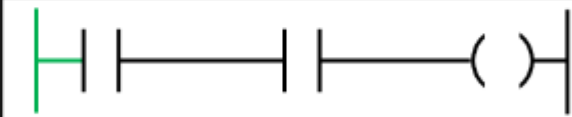
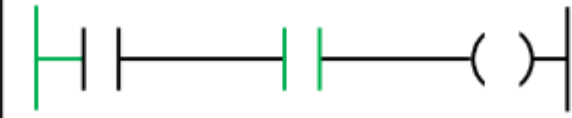


Because PLC input A and B follows the binary concept and are part of the AND function there are four possible logic iterations.

INPUTS		OUTPUT
A	B	Y
FALSE	FALSE	FALSE
FALSE	TRUE	FALSE
TRUE	FALSE	FALSE
TRUE	TRUE	TRUE

Truth Table - AND Function

The number of logic iterations increases with the number of PLC inputs ( $2^{\text{PLC Inputs}}$ ). But that doesn't matter too much with the AND function because the result can only be TRUE if all the PLC inputs are TRUE.

If we translate an AND function into a ladder logic truth table we get the table below....

	INPUTS		OUTPUT
	A	B	Y
A= FALSE B= FALSE Y= FALSE			
A= FALSE B= TRUE Y= FALSE			
A= TRUE B= FALSE Y= FALSE			
A= TRUE B= TRUE Y= TRUE			

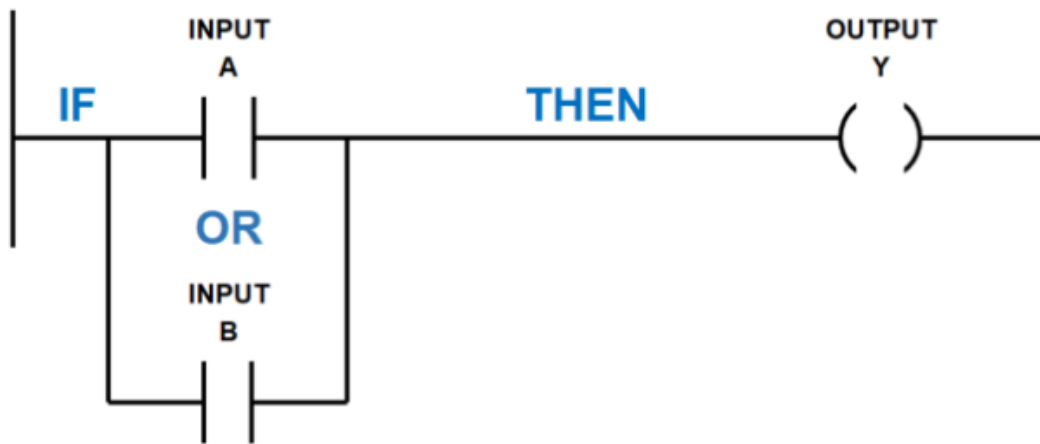
## Ladder Logic OR Function

The OR function examines multiple PLC inputs and has one resulting output.

If we translate an OR function into a ladder diagram we can express it symbolically in the form of two normally open (NO) contacts (PLC inputs A and B) and a relay coil (PLC output Y).

The inputs are placed in the rung in what is known as a branch. This is the equivalent of a parallel connection in an electric circuit.

The output is then connected in line with the rung....



*Ladder Logic Basics – OR Function*

This time we have also highlighted the hidden OR function when we create a branch (parallel connection) with PLC input B across PLC input A.

We can write out the logic expression above as **IF A OR B THEN Y**.

The OR function examines if any of the PLC inputs are TRUE, then the corresponding result is also TRUE. However, all the PLC inputs must be FALSE in order for the corresponding result is also be FALSE.

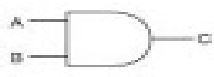


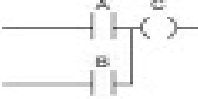
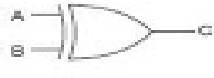
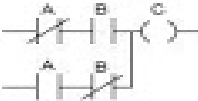
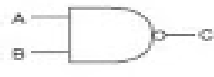
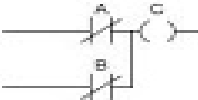
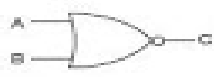

Because PLC input A and B follows the binary concept and are part of the OR function there are four possible logic iterations.

INPUTS		OUTPUT
A	B	Y
FALSE	FALSE	FALSE
FALSE	TRUE	TRUE
TRUE	FALSE	TRUE
TRUE	TRUE	TRUE

*Truth Table – OR Function*

		OUTPUT
		Y
A= FALSE B= FALSE Y= FALSE	INPUT A	
	INPUT B	
A= FALSE B= TRUE Y= TRUE	INPUT A	
	INPUT B	
A= TRUE B= FALSE Y= TRUE	INPUT A	
	INPUT B	
A= TRUE B= TRUE Y= TRUE	INPUT A	
	INPUT B	

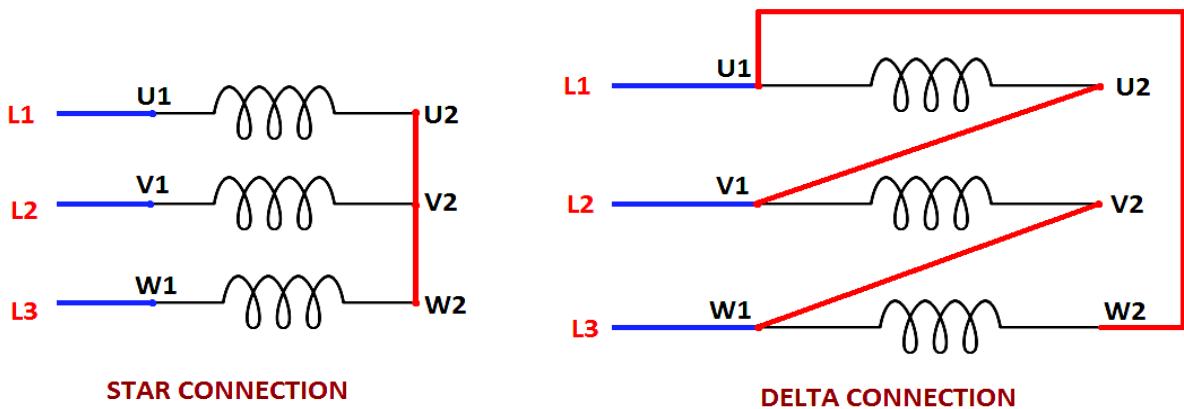
Ladder Logic Basics Truth Table – OR Function

Logic Diagram	Truth Table	Ladder Diagram															
 <p>AND Gate</p>	<table border="1"> <thead> <tr> <th>A</th> <th>B</th> <th>C</th> </tr> </thead> <tbody> <tr><td>0</td><td>0</td><td>0</td></tr> <tr><td>0</td><td>1</td><td>0</td></tr> <tr><td>1</td><td>0</td><td>0</td></tr> <tr><td>1</td><td>1</td><td>1</td></tr> </tbody> </table>	A	B	C	0	0	0	0	1	0	1	0	0	1	1	1	 <p>AND Equivalent Circuit</p>
A	B	C															
0	0	0															
0	1	0															
1	0	0															
1	1	1															
 <p>OR Gate</p>	<table border="1"> <thead> <tr> <th>A</th> <th>B</th> <th>C</th> </tr> </thead> <tbody> <tr><td>0</td><td>0</td><td>0</td></tr> <tr><td>0</td><td>1</td><td>1</td></tr> <tr><td>1</td><td>0</td><td>1</td></tr> <tr><td>1</td><td>1</td><td>1</td></tr> </tbody> </table>	A	B	C	0	0	0	0	1	1	1	0	1	1	1	1	 <p>OR Equivalent Circuit</p>
A	B	C															
0	0	0															
0	1	1															
1	0	1															
1	1	1															
 <p>Exclusive-OR Gate</p>	<table border="1"> <thead> <tr> <th>A</th> <th>B</th> <th>C</th> </tr> </thead> <tbody> <tr><td>0</td><td>0</td><td>0</td></tr> <tr><td>0</td><td>1</td><td>1</td></tr> <tr><td>1</td><td>0</td><td>1</td></tr> <tr><td>1</td><td>1</td><td>0</td></tr> </tbody> </table>	A	B	C	0	0	0	0	1	1	1	0	1	1	1	0	 <p>Exclusive-OR Equivalent Circuit</p>
A	B	C															
0	0	0															
0	1	1															
1	0	1															
1	1	0															
 <p>NAND Gate</p>	<table border="1"> <thead> <tr> <th>A</th> <th>B</th> <th>C</th> </tr> </thead> <tbody> <tr><td>0</td><td>0</td><td>1</td></tr> <tr><td>0</td><td>1</td><td>1</td></tr> <tr><td>1</td><td>0</td><td>1</td></tr> <tr><td>1</td><td>1</td><td>0</td></tr> </tbody> </table>	A	B	C	0	0	1	0	1	1	1	0	1	1	1	0	 <p>NAND Equivalent Circuit</p>
A	B	C															
0	0	1															
0	1	1															
1	0	1															
1	1	0															
 <p>NOR Gate</p>	<table border="1"> <thead> <tr> <th>A</th> <th>B</th> <th>C</th> </tr> </thead> <tbody> <tr><td>0</td><td>0</td><td>1</td></tr> <tr><td>0</td><td>1</td><td>0</td></tr> <tr><td>1</td><td>0</td><td>0</td></tr> <tr><td>1</td><td>1</td><td>0</td></tr> </tbody> </table>	A	B	C	0	0	1	0	1	0	1	0	0	1	1	0	 <p>NOR Equivalent Circuit</p>
A	B	C															
0	0	1															
0	1	0															
1	0	0															
1	1	0															

## PLC LADDER DIAGRAM FOR DOL STARTER AND STAR-DELTA STARTER

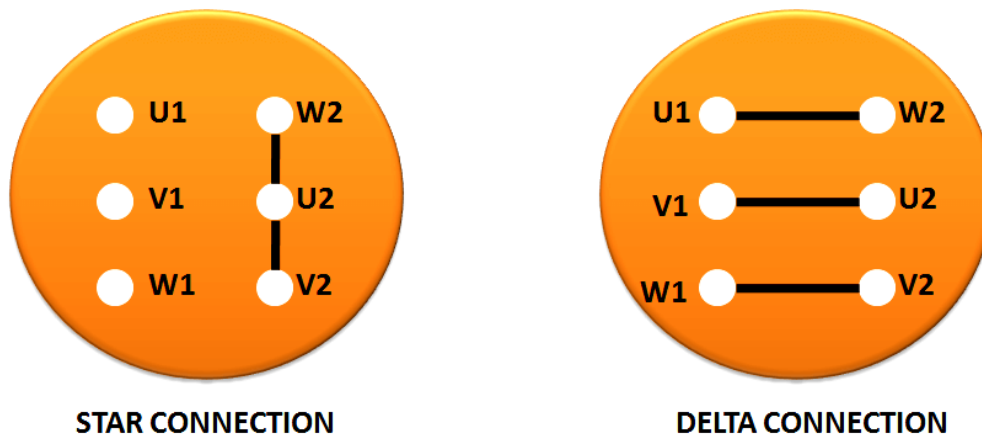
### Star Delta Motor Starter

The following figure shows the winding connections in star and delta configuration one by one.



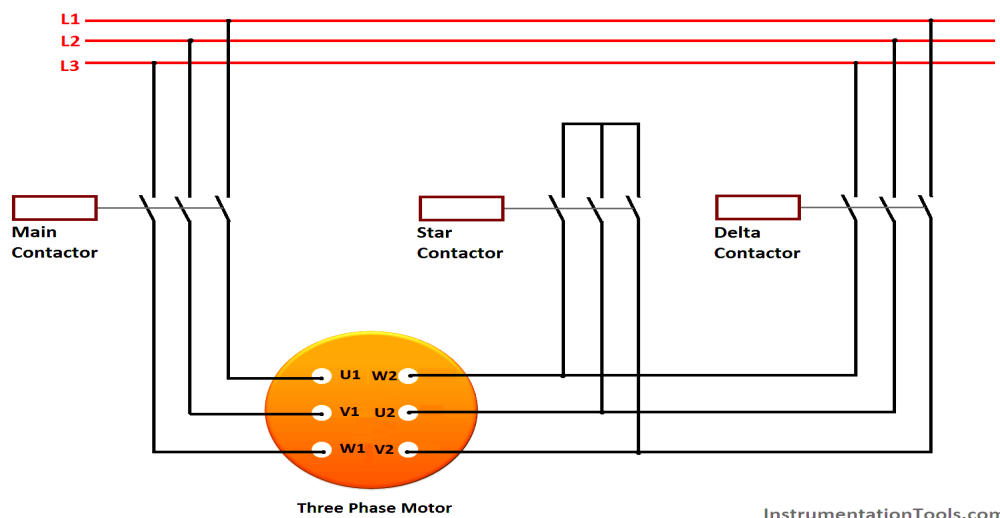
It can be seen that in star connection, one end of all three windings are shorted to make star point while other end of each winding is connected to power supply. In delta configuration, the windings are connected such that to make a close loop.

The connection of each winding is shown in above figure. In actual motor the three phase connections are provided in the following order as shown



InstrumentationTools.com

So in order to make winding connection in star and delta style in practical motor, the connection is shown above.



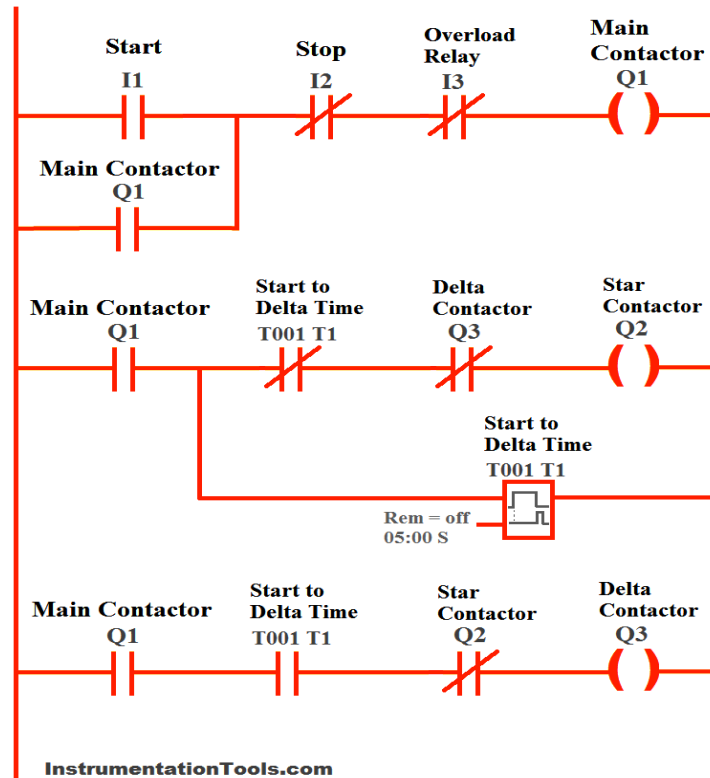
InstrumentationTools.com

Main contractor is used to supply power to the windings. It must be turned on all the time. Initially the star contactor is closed while delta contactor is open It makes the motor windings in star configuration.

When the motor gains speed, the star contactor is opened while delta contactor is closed turning the motor windings into delta configuration.



## STAR-DELTA MOTOR STARTER LADDER LOGIC



### Rung 1 Main contactor :

The main contactor depends upon the normally open input start push button (I1), normally closed stop button (I2) and normally closed overload relay.

It means that Main contactor will only be energized if start button is pressed, while stop is not pressed and overload relay is not activated. A normally open input named (Q1) is added in parallel to the start button I1.

By doing so, a push button is created which means that once motor is started, it will be kept started even if start button is released

### Rung 2 Star contactor:

Star contactor depends upon main contactor, normally close contacts of timer (T1), and normally close contacts of output delta contactor (Q3).

So star contactor will only be energized if main contactor is ON, time output is not activated and delta contactor is not energized.

### Timer T1:

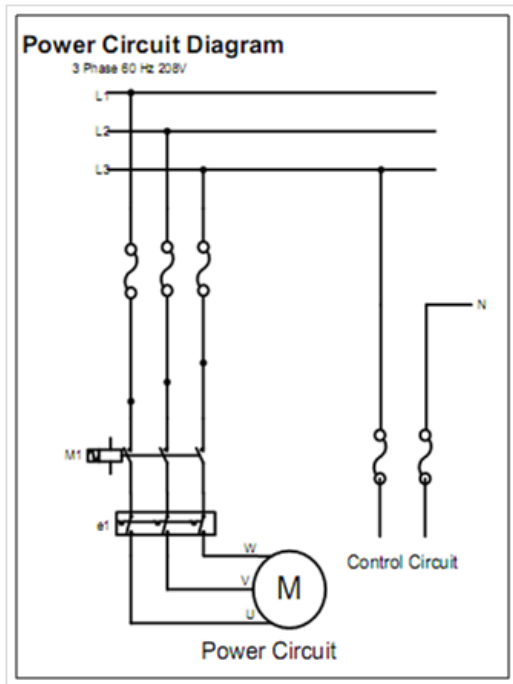
*Timer T1 measures the time after which the winding connection of star delta starter is to be changed. It will start counting time after main contactor is energized.*

### Rung 3 Delta contactor:

Delta contactor will be energized when main contactor (Q1) is energized, timer T1 is activated and star contactor (Q3) is de-energized.

## **PLC Ladder Practice Problem (DOL STARTER)**

Design and connect a ladder logic control for a simple starter system of a 3 phase AC motor. The starter has one start and one stop switch. Both of the switches are momentary contact switch. Start switch is normally open and stop switch is normally close. Output relay, C1, Controls the 3-phase supply to the motor. The motor has a stop and a run indicator lights.



Direct on Line Motor Start Stop using PLC

## **EQUIPMENT AND SUPPLIES**

1. PLC with Input and Output Modules
2. 3 Phase AC Motor, Momentary contact switches
3. Electromagnetic contactors or solid state relays
4. 230V, 15A rated wires

### **Number of PLC Inputs Required**

X1- Start Switch (NO)

X2- Stop Switch (NC)

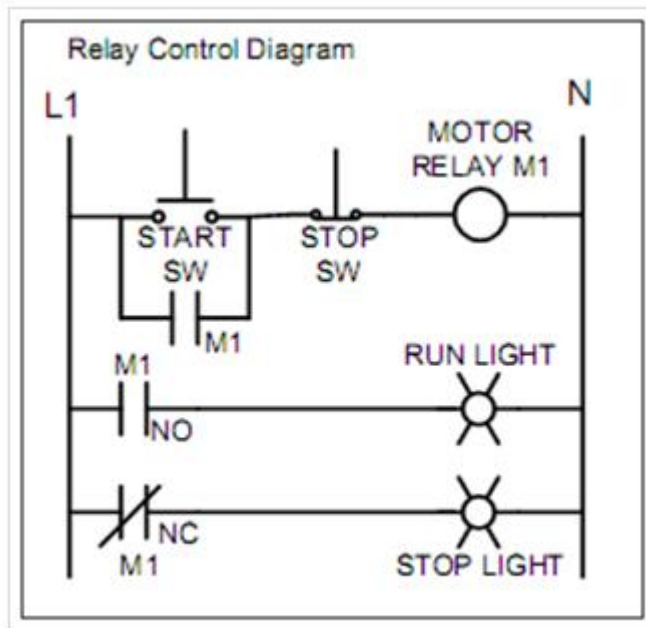
### **Number of PLC Outputs Required**

Y0- Motor Relay

Y1- Motor Run Light

Y2- Motor Stop Light

**PLC Ladder Programming:**



PLC Ladder Program for DOL Motor Starter

**PLC Ladder Programming Description:**

When Start Push button Pressed Motor Relay M1 will on and Latched similarly RUN light will be on. When Stop Button Pressed Latch gets open and Motor Relay gets OFF Hence Motor.